

- NOTES:**
- 1. SECURE CONDUIT 41953, TAB AS REQUIRED, OVER ALL WIRES IN CONTACT WITH SHARP EDGES.
 - 2. USE WIRE TIES 8343-04-000 AND 116673-02-000 APPROXIMATELY 600MM ON CENTER UNLESS OTHERWISE SPECIFIED.
 - 3. SEE RADIO/MONITOR INSTL FOR ADDITIONAL INFORMATION.
 - 4. CUT LIGHT GREEN/RED WIRE FROM PARK BRAKE SWITCH AND RECONNECT TO CIRCUIT DY OF CHASSIS ASM AS SHOWN.
 - 5. SEE BATTERY INSTL FOR ADDITIONAL INFORMATION.
 - 6. FUSE LOCATED UNDER DASH BY STEERING COLUMN.
 - 7. SEE WIRING INSTL-BODY, 110V FOR ADDITIONAL INFORMATION.
 - 8. WIRE ASM TO BE ROUTED FROM CHASSIS ELECTRICAL BOX TO POCKET IN DASH UNDER STEERING COLUMN.
 - 9. ATTACH DUAL LOCK TO BOTTOM OF TRANSMITTER AND ATTACH TO BOTTOM OF POCKET IN DASH.
 - 10. LABEL ON TRANSMITTER MUST FACE UPWARD.

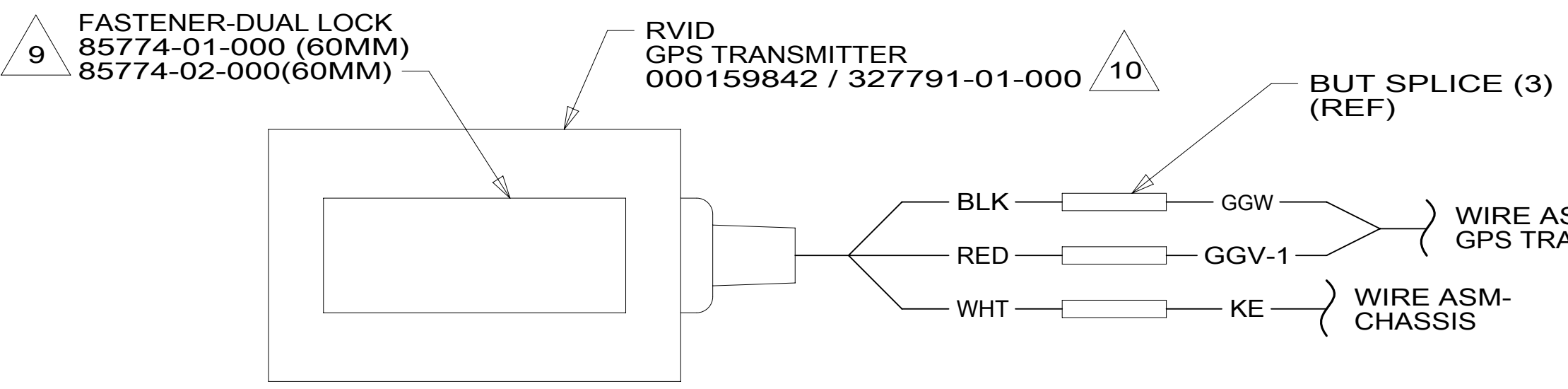

FOR ELECTRICAL TORQUE SPECIFICATIONS SEE DWG NO. 128783-01-000

FOR ELECTRICAL CALLOUTS SEE DWG NO. 121339-01-000

- 65Q RENTAL - APOLLO
- 265 CODES/STANDARDS-CSA/CMVSS
- 1B1 CODES/STANDARDS USA



DSNR:		ALL DIMENSIONS ARE IN MILLIMETERS	
DIFFR:		MATERIAL:	
UNSPECIFIED TOLERANCES:	WHOLE DIM (X)	3	
	ONE-PLACE (X.X)	1.5	
	TWO-PLACE (X.XX)	0.50	
	ANGLE	1°	
REFER TO ES0018 FOR FASTENER TIGHTENING GUIDELINES		WEIGHT: (LBS)	FIRST USED:
			19 927D
DESCRIPTION:			
WIRING INSTL-CHASSIS			
SHEET:	ITEM/PART NO.:	REV:	
1 OF 2	000129823 / 32535901000		
REF:		1 02-Oct-2018	

