

8 7 6 5 4 3 2 1

BB

BA

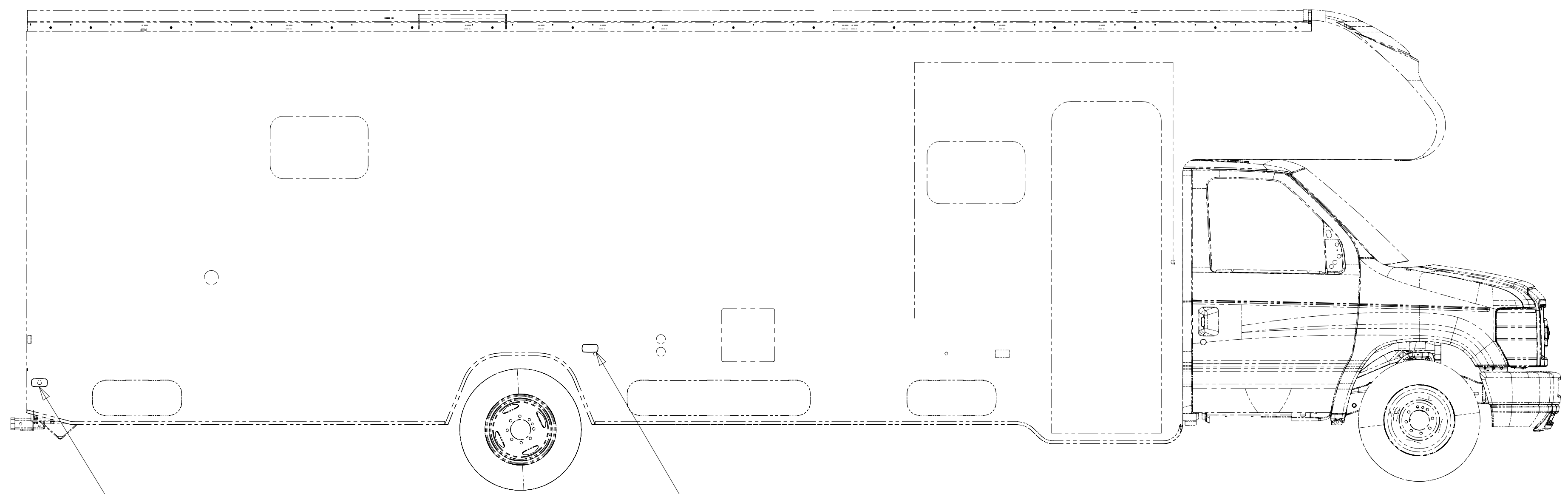

LAMP-MARKER,W RED LENS,WHT
193802-02-000
SCREW
G11-08-12U (2)

LAMP-MARKER,W AMBER LENS,WHT
193802-01-000
SCREW
G11-08-12U (2)

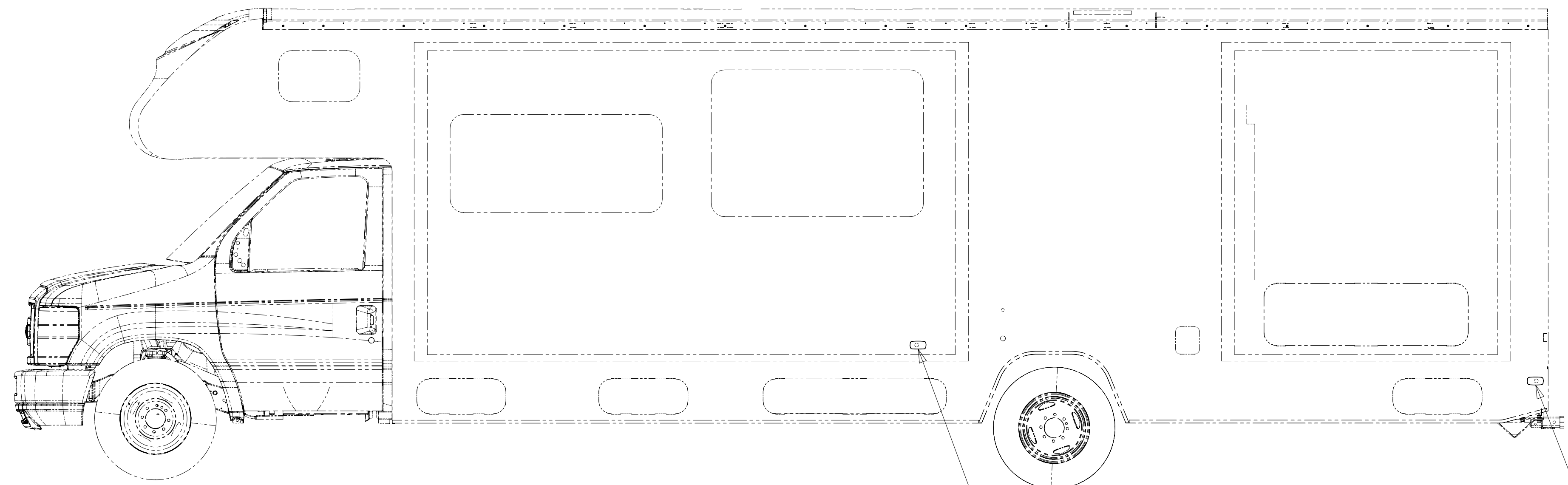

LAMP-MARKER,W AMBER LENS,WHT
193802-01-000
SCREW
G11-08-12U (2)

LAMP-MARKER,W RED LENS,WHT
193802-02-000
SCREW
G11-08-12U (2)

265 CODES/STANDARDS-CSA/CMVSS

1B1 CODES/STANDARDS USA

1B1 265

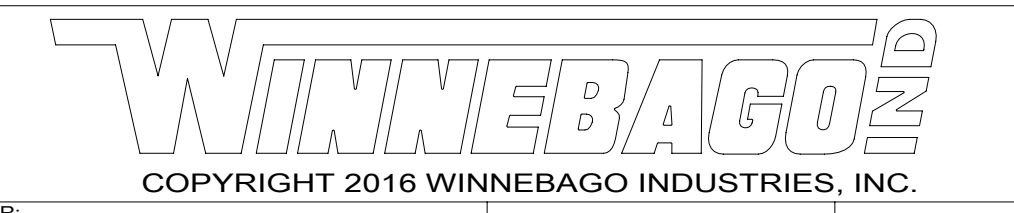

DSNR:		ALL DIMENSIONS ARE IN MILLIMETERS	
DFFR:		MATERIAL:	
UNSPECIFIED TOLERANCES:			
WHOLE DIM (X)	: 3		
ONE-PLACE (X.X)	: 1.5		
TWO-PLACE (X.XX)	: 0.50		
ANGLE	: 1°		
REFER TO ES0018 FOR FASTENER TIGHTENING GUIDELINES		WEIGHT: (LBS)	FIRST USED:
			19 931N

FOR ELECTRICAL TORQUE SPECIFICATIONS SEE DWG NO. 128783-01-000

FOR ELECTRICAL CALLOUTS SEE DWG NO. 121339-01-000

DESCRIPTION: WIRING INSTL-EXTERIOR LAMPS

SHEET: 1 OF 2 ITEM/PART NO: 000123879 / 32618601000 REV:

8 7 6 5 4 3 2 1

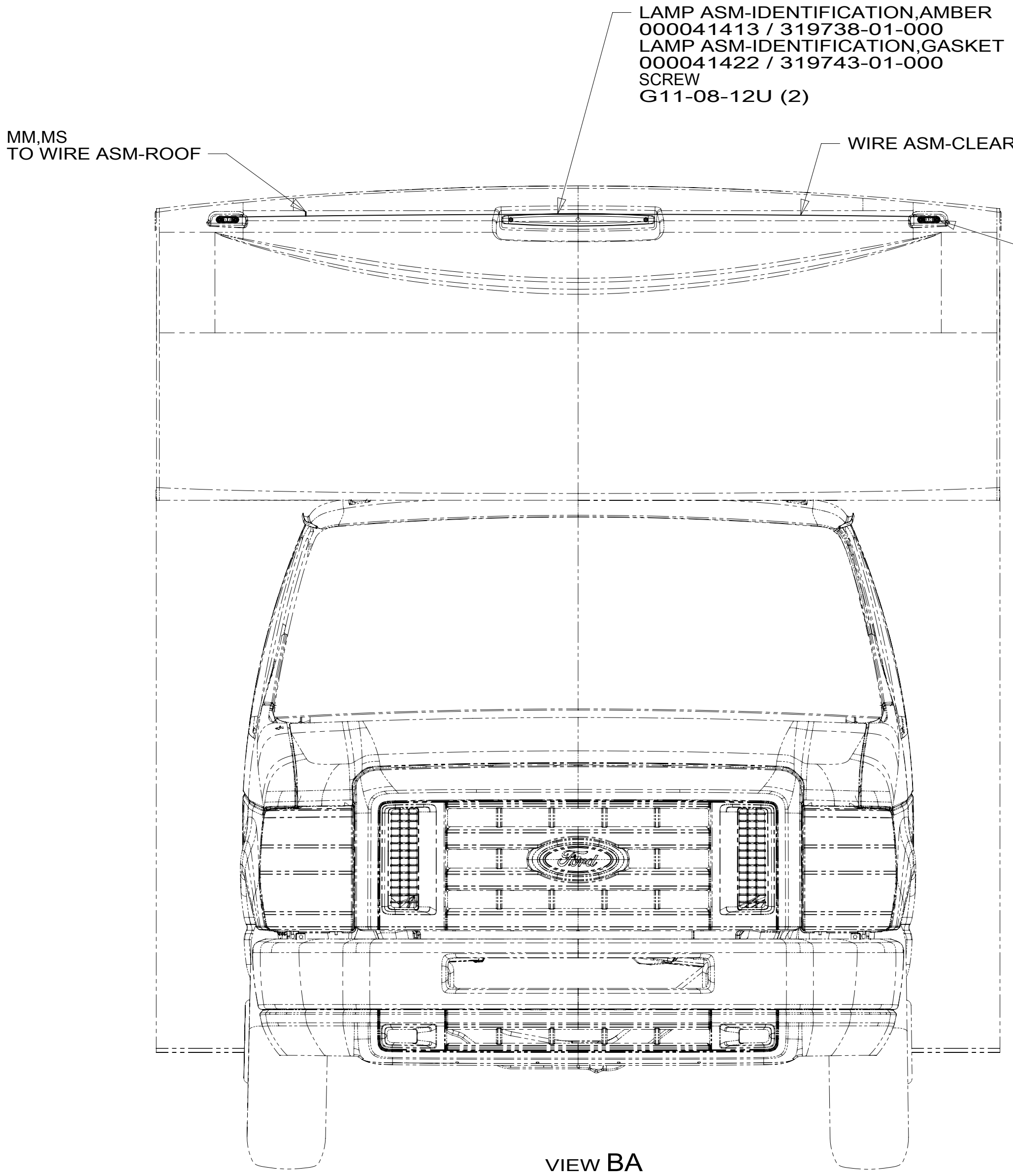

VIEW BA

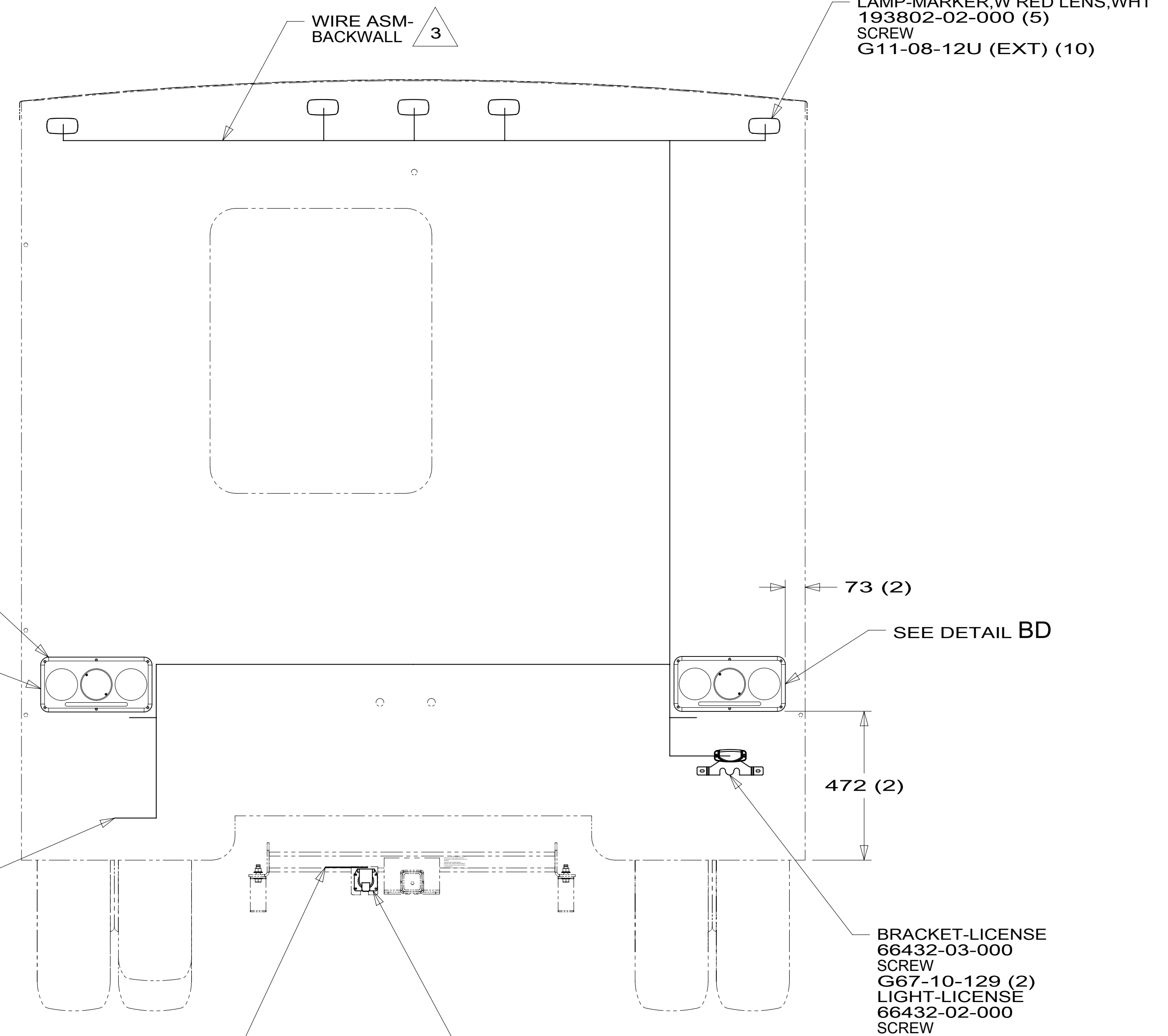

VIEW BB

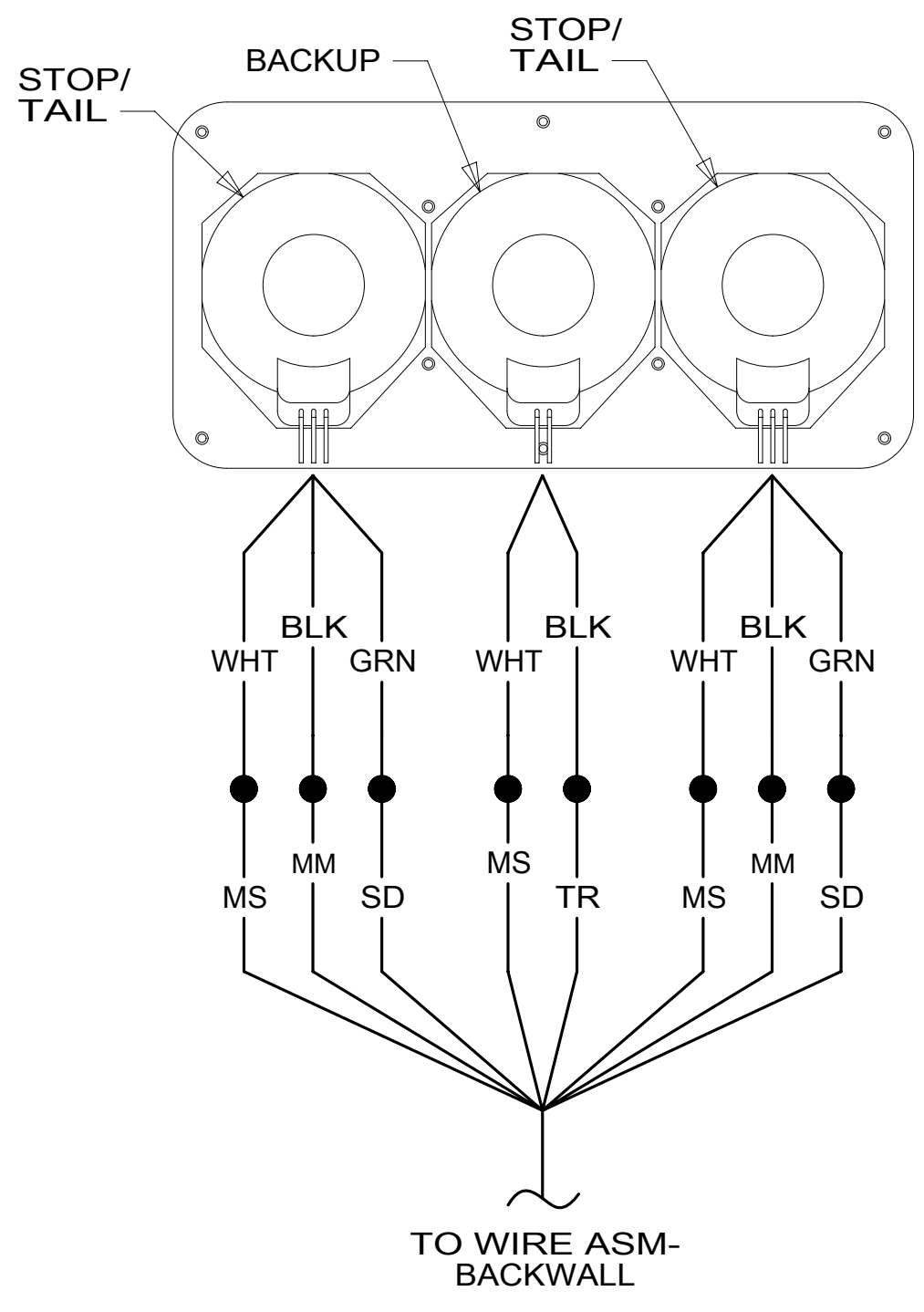

DETAIL BC

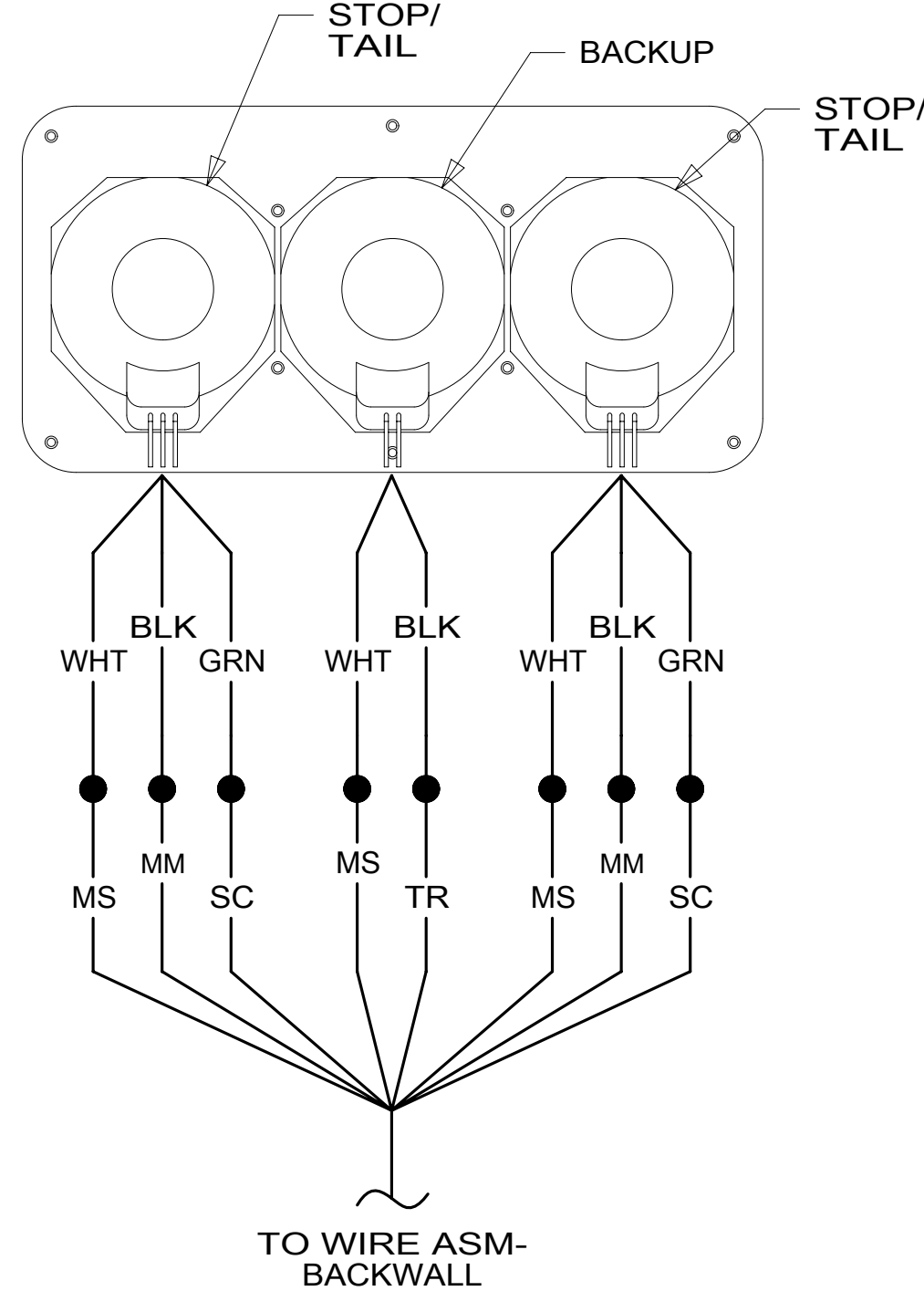

DETAIL BD

- NOTES:
- 4 TAIL LAMP MUST BE INSTALLED WITH WIRES DOWN.
 - 3 LOCATED IN BACKWALL ASM.
 - 2 SECURE WIRE BELOW COACH WITH CLAMP 10495-01-000 AND SCREW G67-10-12U.
 - 1 LOCATED IN ROOF ASM-FRONT.

FOR ELECTRICAL TORQUE SPECIFICATIONS SEE DWG NO. 128783-01-000

FOR ELECTRICAL CALLOUTS SEE DWG NO. 121339-01-000

- 265 CODES/STANDARDS-CSA/CMVSS
- 1B1 CODES/STANDARDS USA

DESCRIPTION:		1B1 265
WIRING INSTL-EXTERIOR LAMPS		
SHEET:	ITEM/PART NO.:	REV
2 OF 2	000123879 / 32618601000	