

- 9 COVER ALL WIRES AND CABLES WITH CONVOLUTED TUBING. SECURE TO TV BRACKET SO THAT WIRES AND CABLES DO NOT BECOME PINCHED.
- 8 SEE WIRE ASM-SOLAR SYSTEM AND WIRE INSTL-CHASSIS FOR ADDITIONAL INFORMATION.
- 7 SEE STEP INSTALLATION FOR ADDITIONAL INFORMATION.
- 6 6 & 8 PIN HOUSINGS SUPPLIED WITH STEP.
- 5 WIRES ARE PART OF WIRE ASM-STEP.
- 4 MOUNT ON EXTERIOR SURFACE OF VAN SIDEWALL.
- 3 PLACE CROSS LOCATOR ON SENSORS OVER DIMPLES ON TANK.

2. ROUTE TANK SENSOR WIRES SO THEY DO NOT PASS OVER SENSORS. USE WIRE TIE MOUNT 155366-01-000 AND WIRE TIE 8343-01-000 AS NEEDED. TANK SURFACE MUST BE CLEANED USING ISOPROPYL ALCOHOL AND PRIMED WITH PRIMER 94.
1. AT MINIMUM ALL WIRES TO BE SUPPORTED AND SECURED PER CODE REQUIREMENTS. USE CLAMP 10495 OR 10497 OR WIRE TIE 8343 OR 108046 AND SCREW G67-XX-XXX OR G56-XX-XXX AS APPROPRIATE FOR INSTALLATION.

NOTES:

- TV-24" HDTV, INSIGNIA 000167921 / 330227-01-000
- ADAPTOR-COAX 90° 176986-01-000
- BRKT ASM-MNTNG,TV,24INSIGN 000118502 / 322456-01-CHT
- NUT 000D24-10-00U (4)
- SCREW 0MG02U-04-012 (4)
- WASHER 0ME02U-04-071 (4)
- SPACER-NYLON 086285-01-000 (4)
- CONVOLUTE 041953-01-000 (1200 MM)
- MOUNT-WIRE TIE 155366-01-000 (2)
- TIE-WIRE 008343-02-000 (2)
- 008343-03-000 (2)

- 1E2 KD TO DOOR SWITCH
- DETAIL AC
- SWITCH
- DETAIL CE
- 3 WIRE ASM-WATER TANK
- 151317-01-000
- TO LEFT SIDE
- USB-CHARGER DUAL,DC
- 188312-01-000
- DETAIL AE

- SWITCH
- DETAIL CB
- RELAY-AWNING
- 063912-02-000
- SCREW
- G11-08-12U
- TO STEP CONTROL
- DETAIL AA
- RELAY
- 063912-02-000
- SCREW
- G11-08-12U
- FUSE-5AMP
- 062901-02-000
- WIRE ASM-STEP
- 000001752 / 300024-01-000

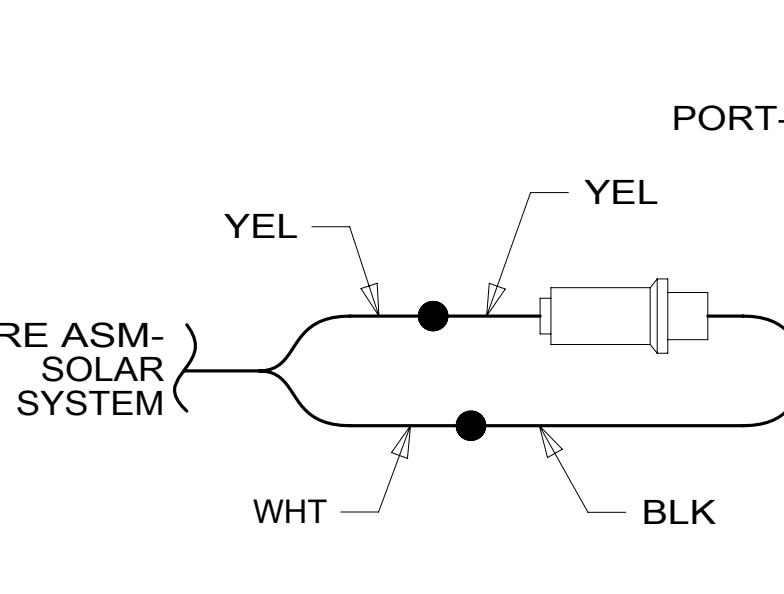
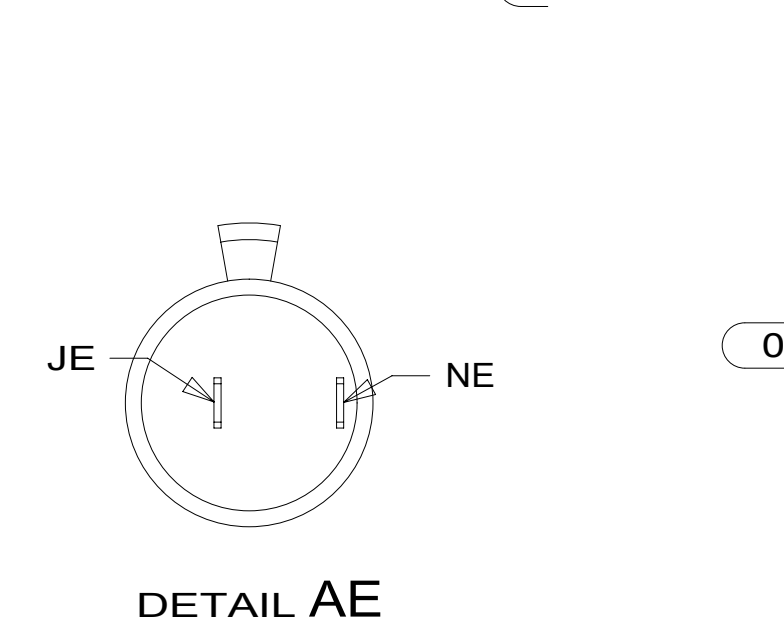

DETAIL AF

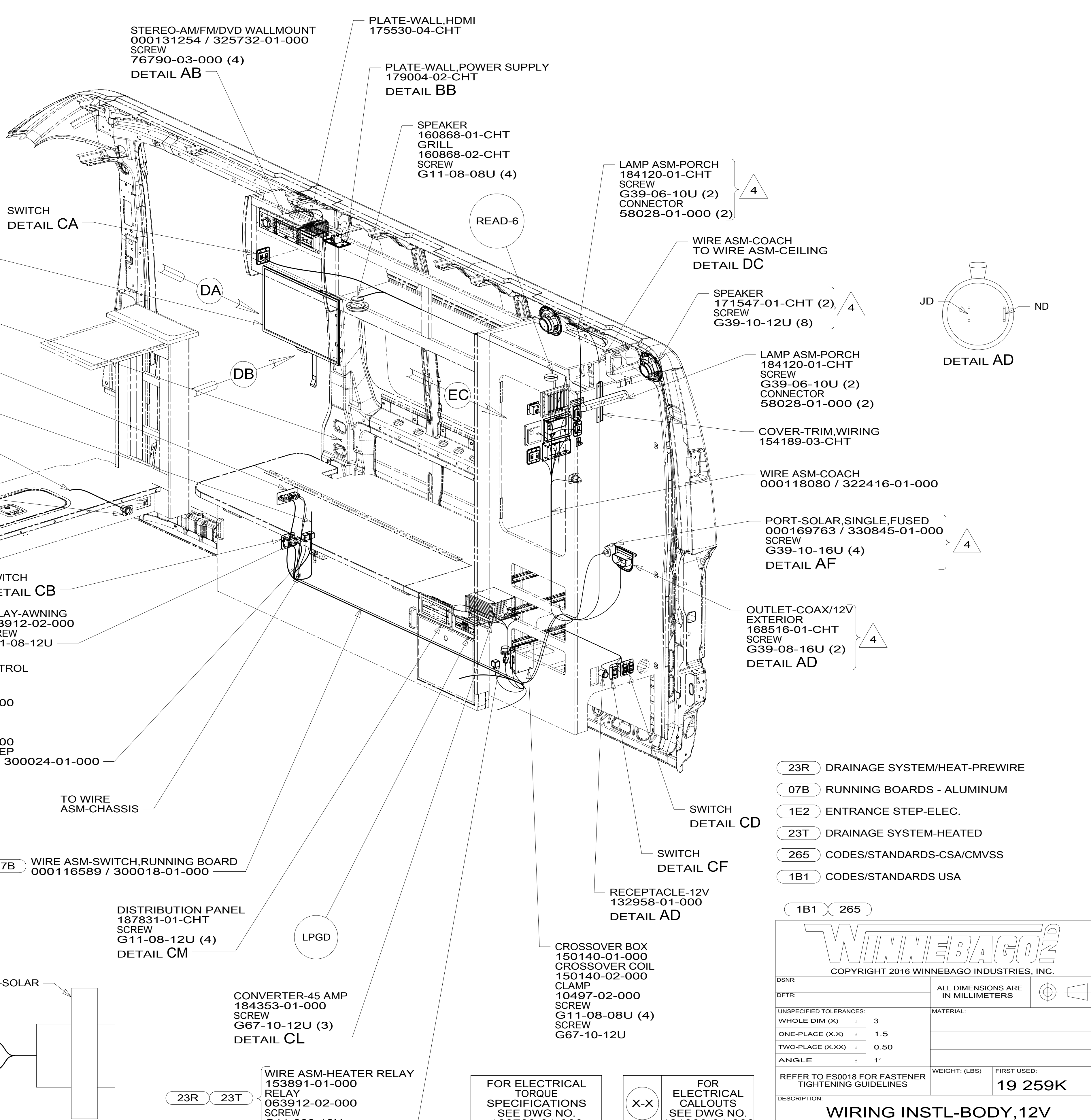

- STEREO-AM/FM/DVD WALLMOUNT 000131254 / 325732-01-000
- SCREW 76790-03-000 (4)
- DETAIL AB
- PLATE-WALL,HDMI 175530-04-CHT
- PLATE-WALL,POWER SUPPLY 179004-02-CHT
- DETAIL BB
- SPEAKER 160868-01-CHT
- GRILL 160868-02-CHT
- SCREW G11-08-08U (4)
- LAMP ASM-PORCH 184120-01-CHT
- SCREW G39-06-10U (2)
- CONNECTOR 58028-01-000 (2)
- WIRE ASM-COACH TO WIRE ASM-CEILING
- DETAIL DC
- SPEAKER 171547-01-CHT (2)
- SCREW G39-10-12U (8)
- LAMP ASM-PORCH 184120-01-CHT
- SCREW G39-06-10U (2)
- CONNECTOR 58028-01-000 (2)
- COVER-TRIM,WIRING 154189-03-CHT
- WIRE ASM-COACH 000118080 / 322416-01-000
- PORT-SOLAR,SINGLE,FUSED 000169763 / 330845-01-000
- SCREW G39-10-16U (4)
- DETAIL AF
- OUTLET-COAX/12V EXTERIOR 168516-01-CHT
- SCREW G39-08-16U (2)
- DETAIL AD
- SWITCH
- DETAIL CD
- SWITCH
- DETAIL CF
- RECEPTACLE-12V 132958-01-000
- DETAIL AD
- CROSSOVER BOX 150140-01-000
- CROSSOVER COIL 150140-02-000
- CLAMP 10497-02-000
- SCREW G11-08-08U (4)
- SCREW G67-10-12U
- CONVERTER-45 AMP 184353-01-000
- SCREW G67-10-12U (3)
- DETAIL CL
- DISTRIBUTION PANEL 187831-01-CHT
- SCREW G11-08-12U (4)
- DETAIL CM
- WIRE ASM-SWITCH,RUNNING BOARD 000116589 / 300018-01-000
- 07B
- TO WIRE ASM-CHASSIS
- TO WIRE ASM-CHASSIS
- WIRE ASM-HEATER RELAY 153891-01-000
- RELAY 063912-02-000
- SCREW G11-008-12U
- FOR ELECTRICAL TORQUE SPECIFICATIONS SEE DWG NO. 128783-01-000
- FOR ELECTRICAL CALLOUTS SEE DWG NO. 121339-01-000

- 1E2
- 3
- 7
- 1E2
- 07B
- 23R
- 23T

- 23R DRAINAGE SYSTEM/HEAT-PREWIRE
- 07B RUNNING BOARDS - ALUMINUM
- 1E2 ENTRANCE STEP-ELEC.
- 23T DRAINAGE SYSTEM-HEATED
- 265 CODES/STANDARDS-CSA/CMVSS
- 1B1 CODES/STANDARDS USA
- 1B1 265

19 259K

WIRING INSTL-BODY, 12V

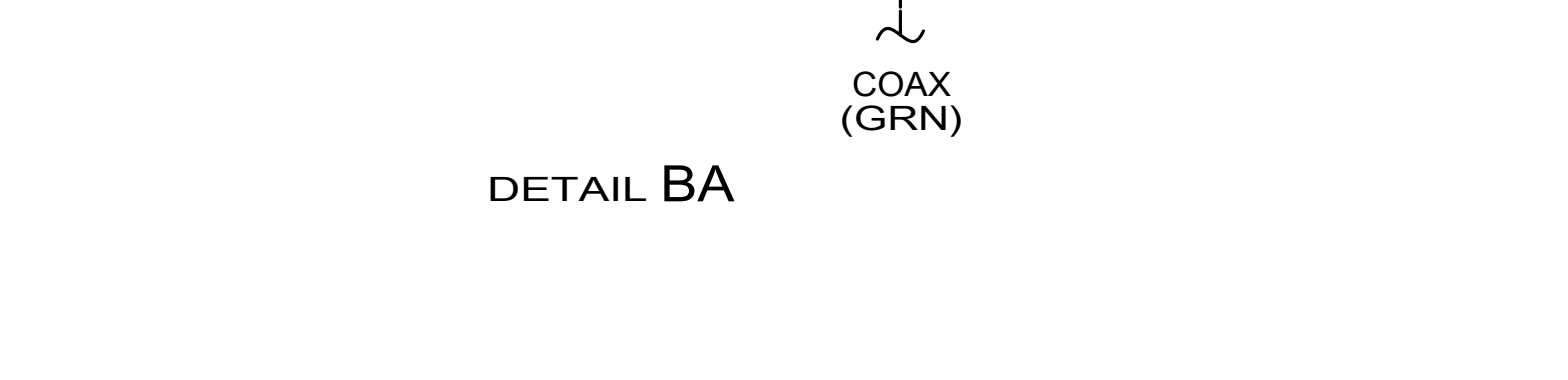
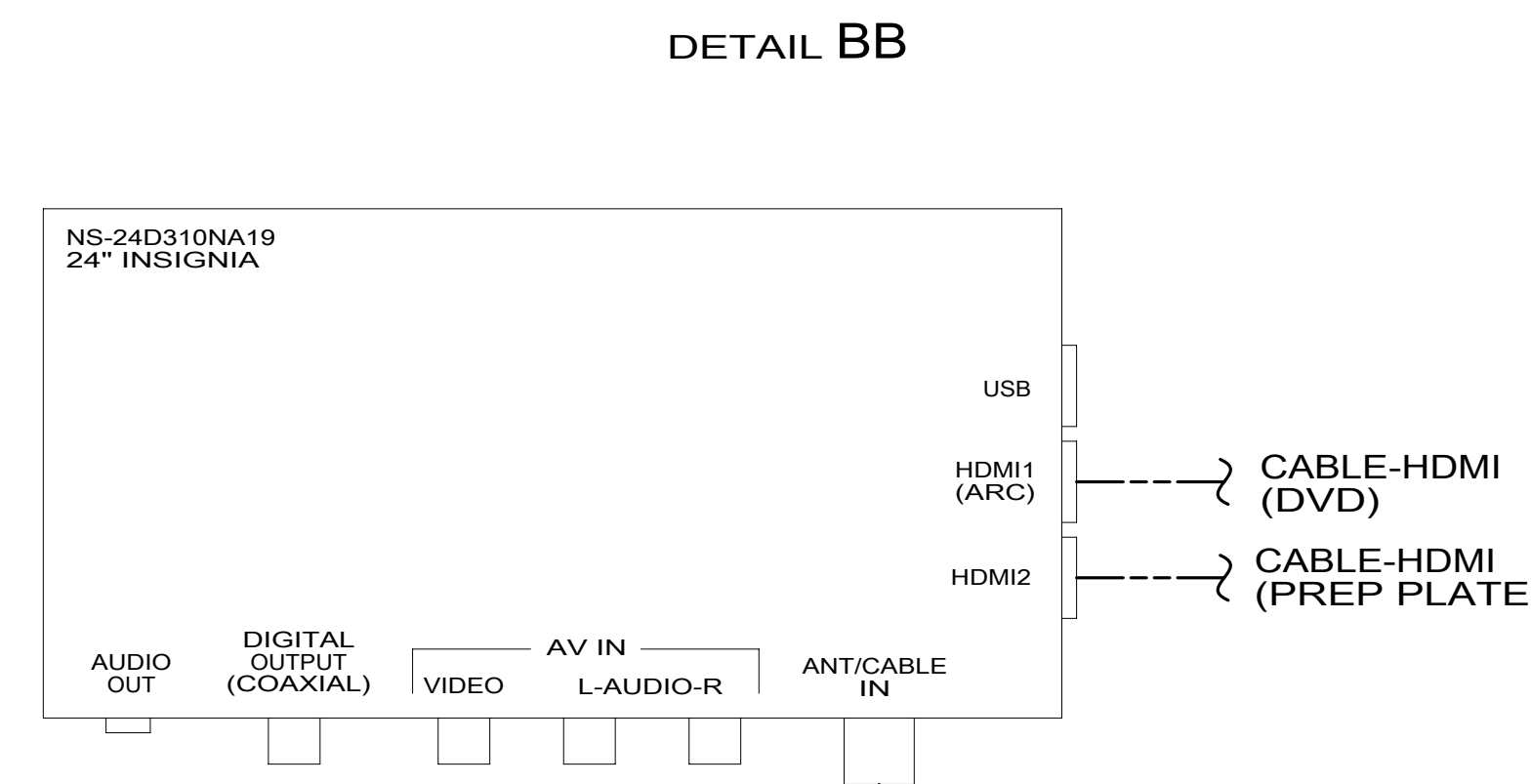
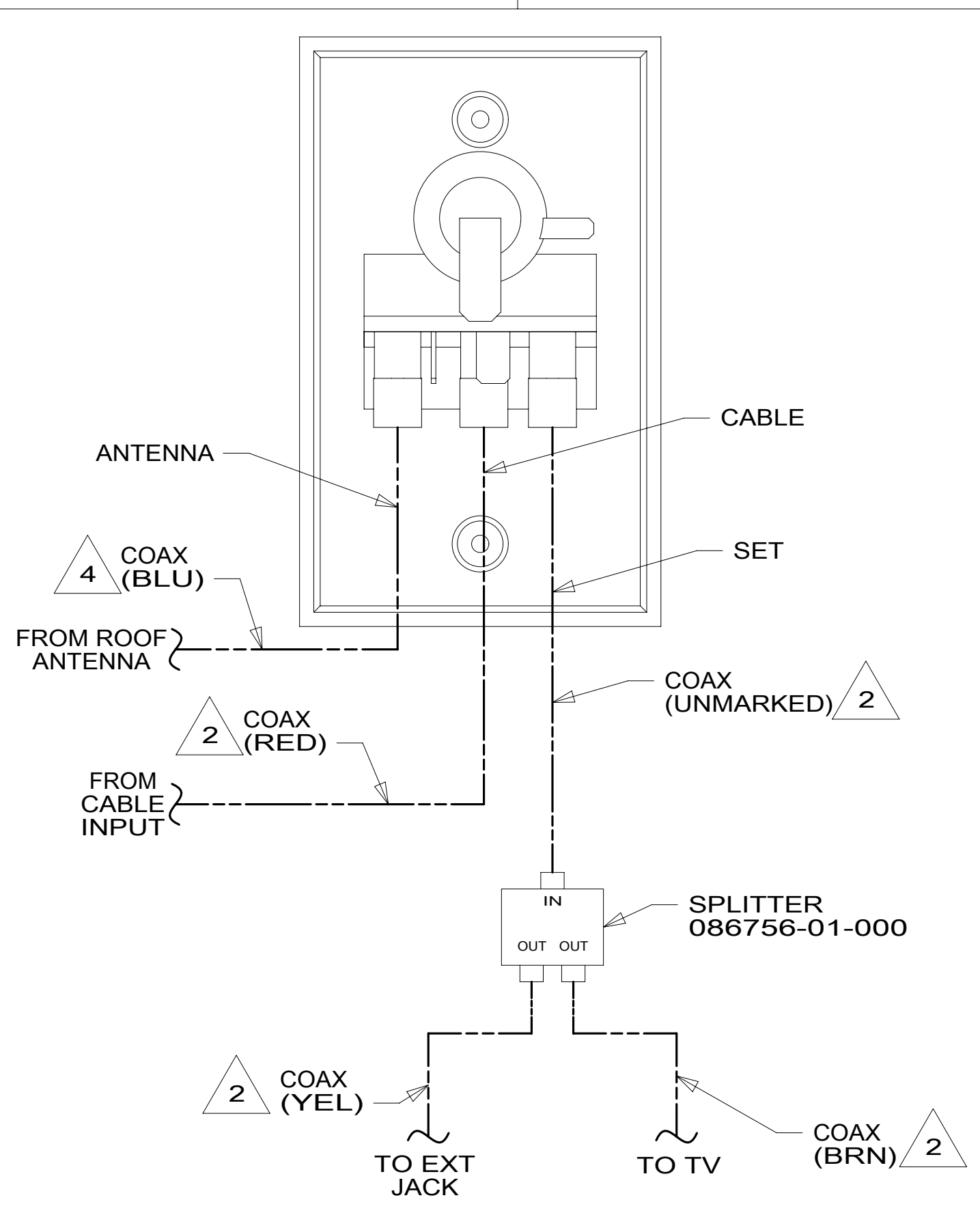
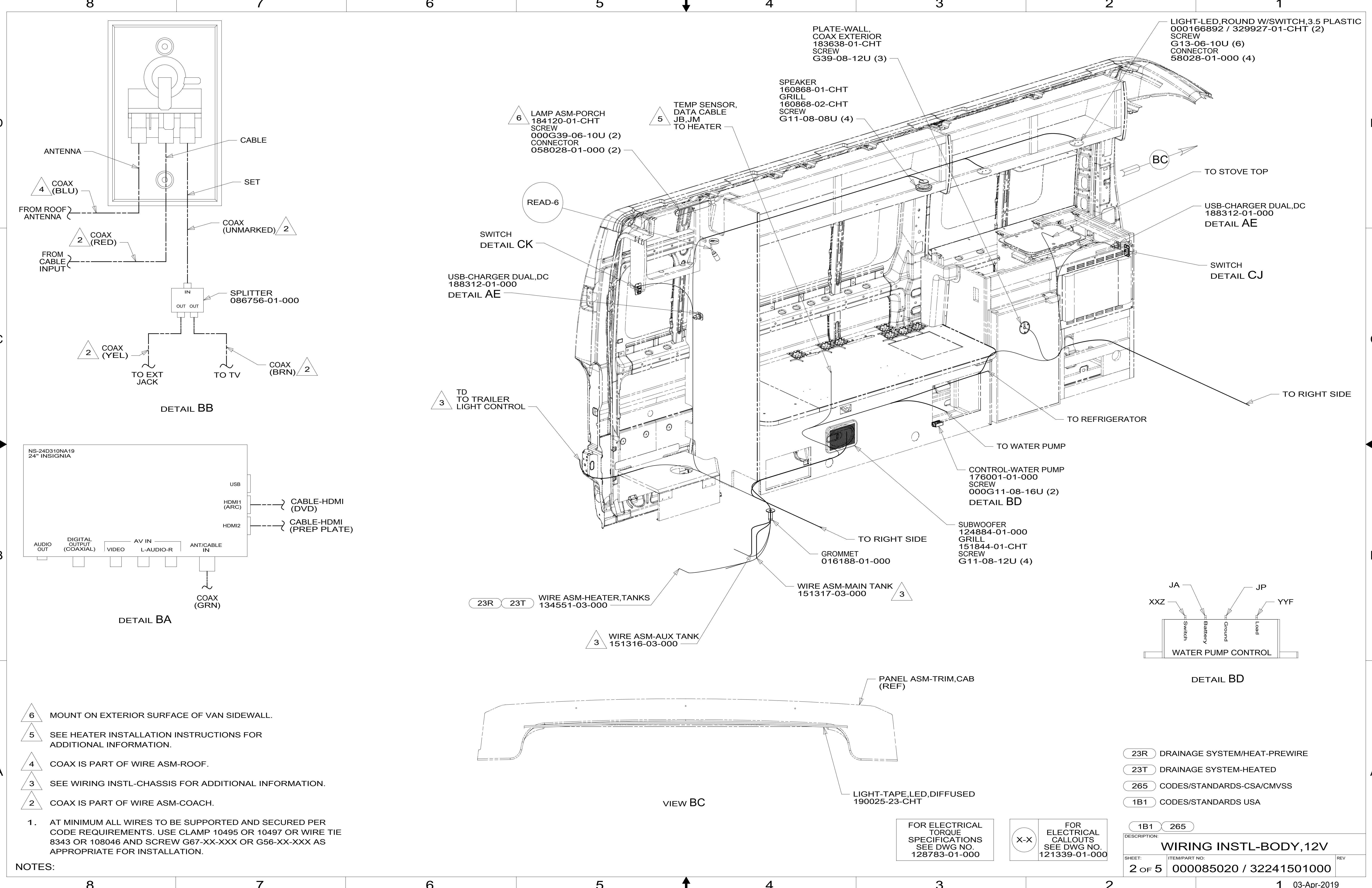

- NOTES:**
- 1. AT MINIMUM ALL WIRES TO BE SUPPORTED AND SECURED PER CODE REQUIREMENTS. USE CLAMP 10495 OR 10497 OR WIRE TIE 8343 OR 108046 AND SCREW G67-XX-XXX OR G56-XX-XXX AS APPROPRIATE FOR INSTALLATION.
 - 2. COAX IS PART OF WIRE ASM-COACH.
 - 3. SEE WIRING INSTL-CHASSIS FOR ADDITIONAL INFORMATION.
 - 4. COAX IS PART OF WIRE ASM-ROOF.
 - 5. SEE HEATER INSTALLATION INSTRUCTIONS FOR ADDITIONAL INFORMATION.
 - 6. MOUNT ON EXTERIOR SURFACE OF VAN SIDEWALL.

- 6 LAMP ASM-PORCH 184120-01-CHT SCREW 000G39-06-10U (2) CONNECTOR 058028-01-000 (2)
- 5 TEMP SENSOR, DATA CABLE JB, JM TO HEATER

- PLATE-WALL, COAX EXTERIOR 183638-01-CHT SCREW G39-08-12U (3)
- SPEAKER 160868-01-CHT GRILL 160868-02-CHT SCREW G11-08-08U (4)

- LIGHT-LED, ROUND W/SWITCH, 3.5 PLASTIC 000166892 / 329927-01-CHT (2) SCREW G13-06-10U (6) CONNECTOR 58028-01-000 (4)

- READ-6
- SWITCH DETAIL CK
- USB-CHARGER DUAL,DC 188312-01-000 DETAIL AE

- 3 TD TO TRAILER LIGHT CONTROL

- 23R 23T WIRE ASM-HEATER,TANKS 134551-03-000

- 3 WIRE ASM-AUX TANK 151316-03-000

- WIRE ASM-MAIN TANK 151317-03-000 3

- CONTROL-WATER PUMP 176001-01-000 SCREW 000G11-08-16U (2) DETAIL BD

- SUBWOOFER 124884-01-000 GRILL 151844-01-CHT SCREW G11-08-12U (4)

- GROMMET 016188-01-000

- TO RIGHT SIDE

- PANEL ASM-TRIM,CAB (REF)

- LIGHT-TAPE,LED,DIFFUSED 190025-23-CHT

- TO STOVE TOP

- USB-CHARGER DUAL,DC 188312-01-000 DETAIL AE

- SWITCH DETAIL CJ

- TO RIGHT SIDE

- TO REFRIGERATOR

- TO WATER PUMP

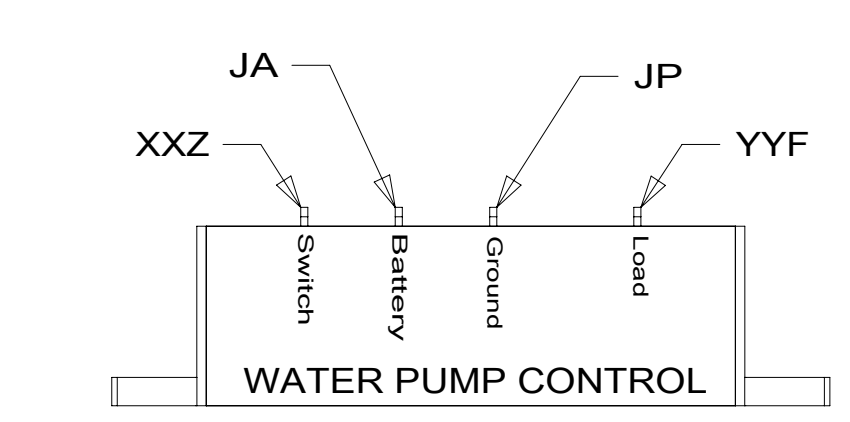

DETAIL BD

- 23R DRAINAGE SYSTEM/HEAT-PREWIRE
- 23T DRAINAGE SYSTEM-HEATED
- 265 CODES/STANDARDS-CSA/CMVSS
- 1B1 CODES/STANDARDS USA

FOR ELECTRICAL TORQUE SPECIFICATIONS SEE DWG NO. 128783-01-000

FOR ELECTRICAL CALLOUTS SEE DWG NO. 121339-01-000

DESCRIPTION: 1B1 265		
WIRING INSTL-BODY, 12V		
SHEET: 2 OF 5	ITEM/PART NO: 000085020 / 32241501000	REV:

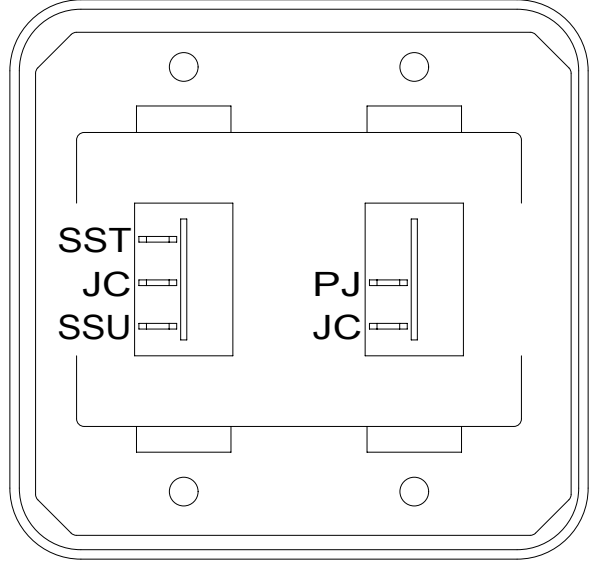
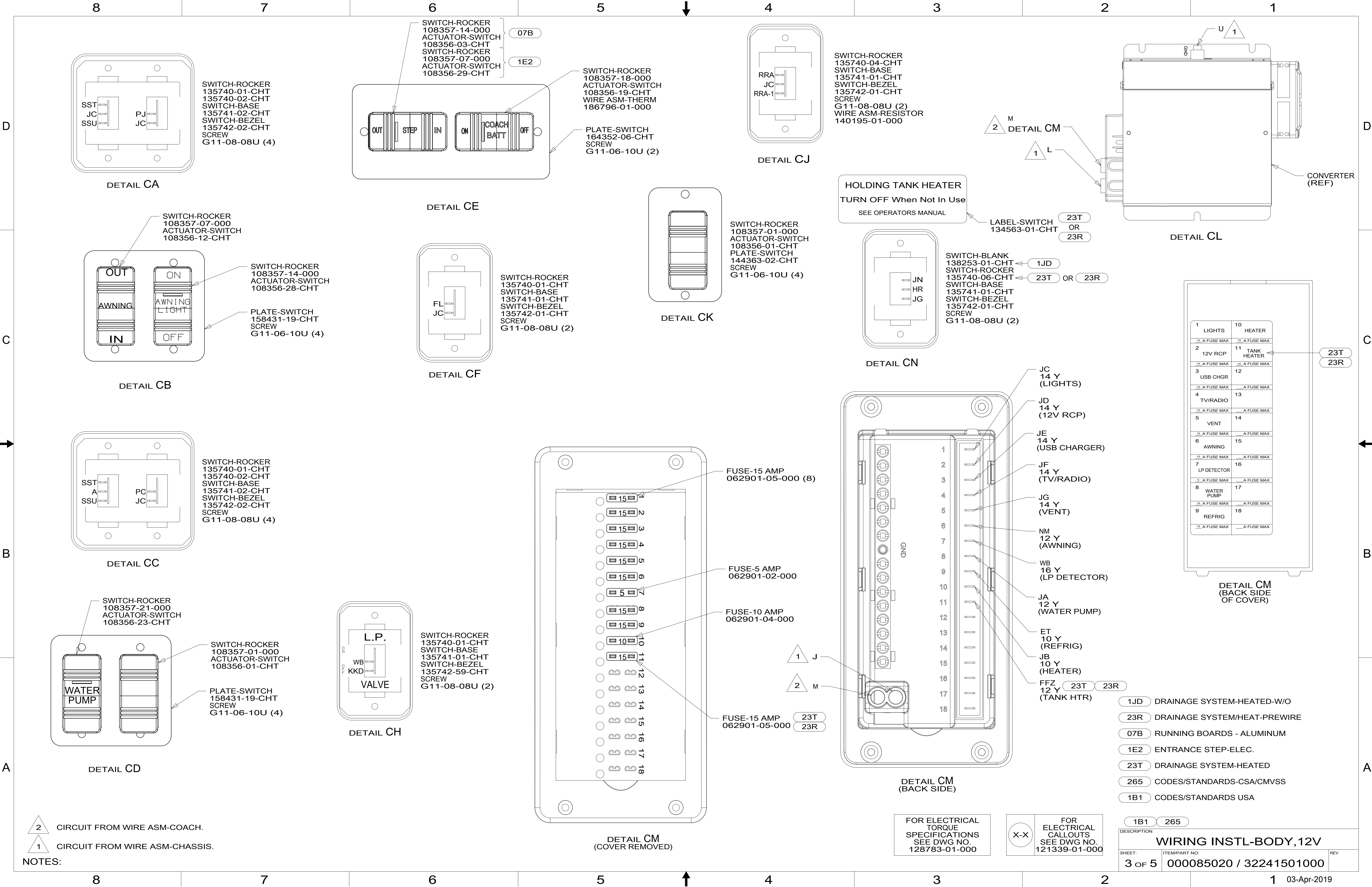

SWITCH-ROCKER
135740-01-CHT
135740-02-CHT
SWITCH-BASE
135741-02-CHT
SWITCH-BEZEL
135742-02-CHT
SCREW
G11-08-08U (4)

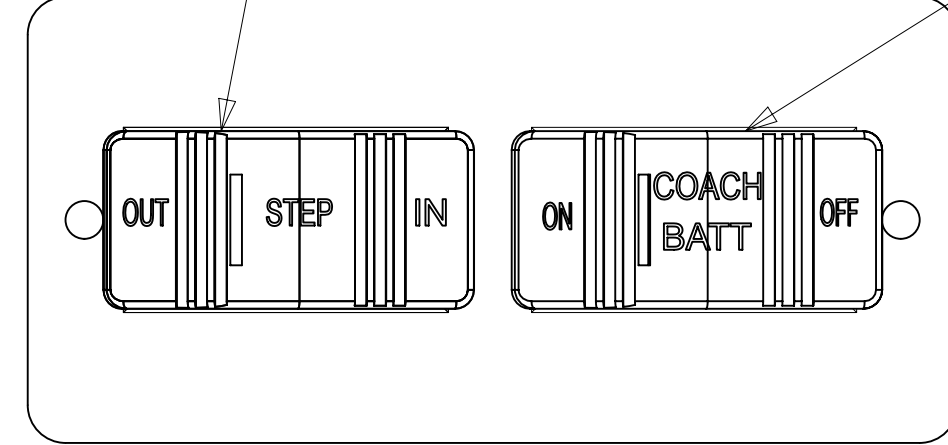

SWITCH-ROCKER
108357-14-000
ACTUATOR-SWITCH
108356-03-CHT
SWITCH-ROCKER
108357-07-000
ACTUATOR-SWITCH
108356-29-CHT

SWITCH-ROCKER
108357-18-000
ACTUATOR-SWITCH
108356-19-CHT
WIRE ASM-THERM
186796-01-000

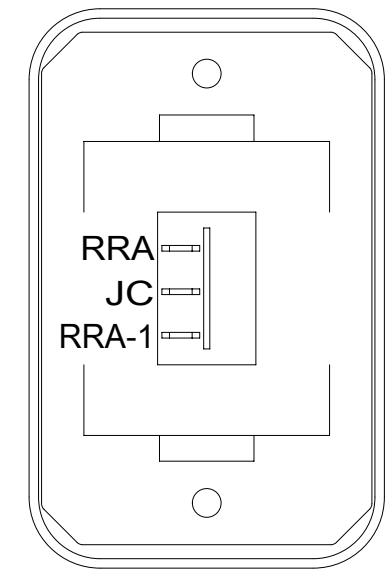

SWITCH-ROCKER
135740-04-CHT
SWITCH-BASE
135741-01-CHT
SWITCH-BEZEL
135742-01-CHT
SCREW
G11-08-08U (2)
WIRE ASM-RESISTOR
140195-01-000

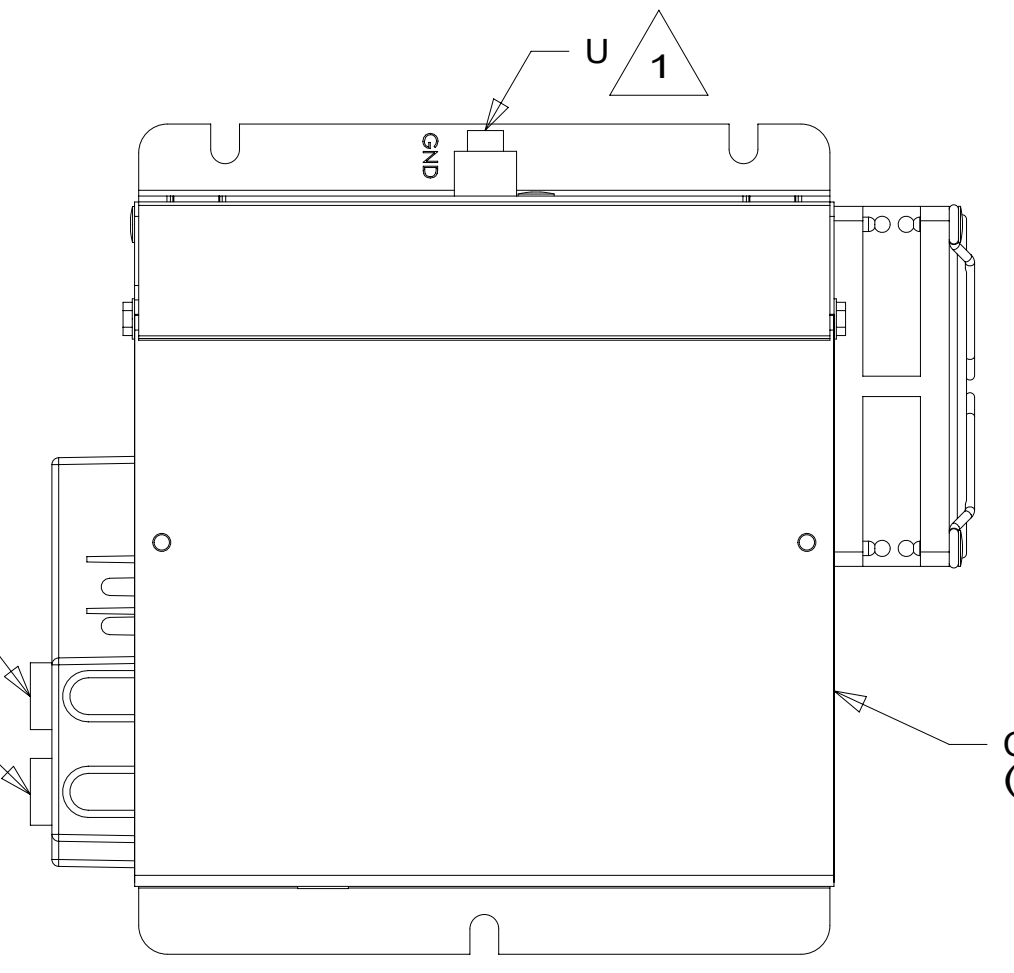

CONVERTER
(REF)

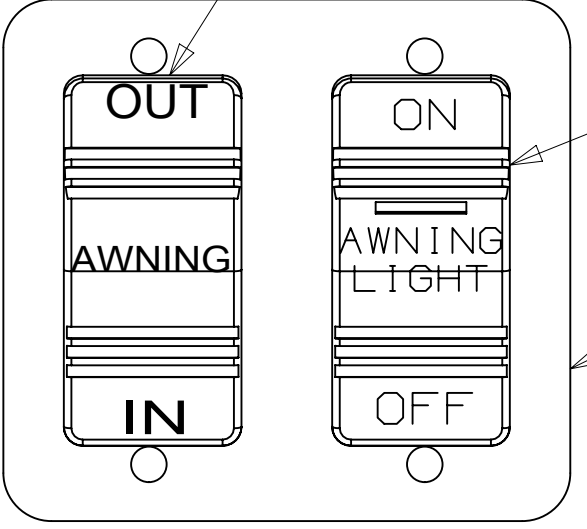

SWITCH-ROCKER
108357-07-000
ACTUATOR-SWITCH
108356-12-CHT

SWITCH-ROCKER
108357-14-000
ACTUATOR-SWITCH
108356-28-CHT

PLATE-SWITCH
158431-19-CHT
SCREW
G11-06-10U (4)

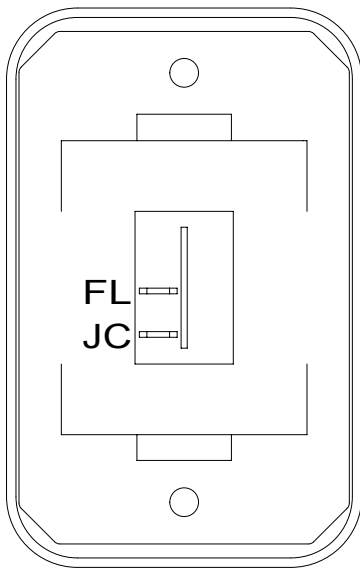

SWITCH-ROCKER
135740-01-CHT
SWITCH-BASE
135741-01-CHT
SWITCH-BEZEL
135742-01-CHT
SCREW
G11-08-08U (2)

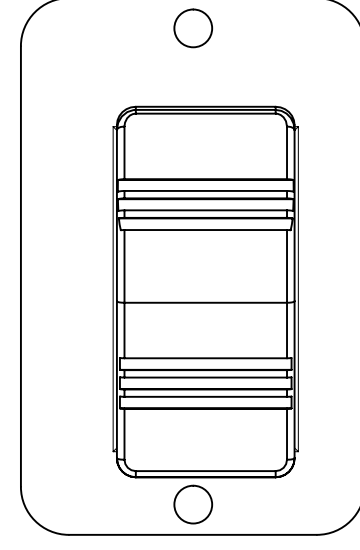

SWITCH-ROCKER
108357-01-000
ACTUATOR-SWITCH
108356-01-CHT
PLATE-SWITCH
144363-02-CHT
SCREW
G11-06-10U (4)

HOLDING TANK HEATER
TURN OFF When Not In Use
SEE OPERATORS MANUAL

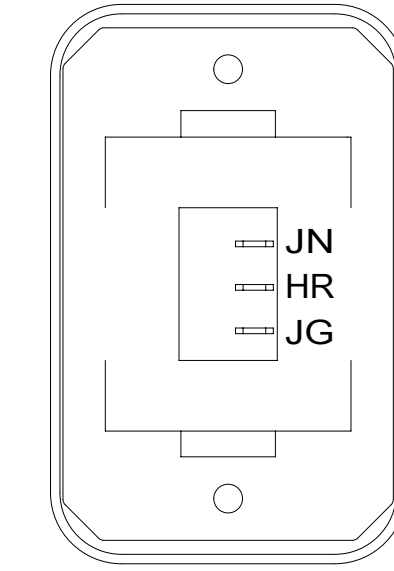

SWITCH-BLANK
138253-01-CHT
SWITCH-ROCKER
135740-06-CHT
SWITCH-BASE
135741-01-CHT
SWITCH-BEZEL
135742-01-CHT
SCREW
G11-08-08U (2)

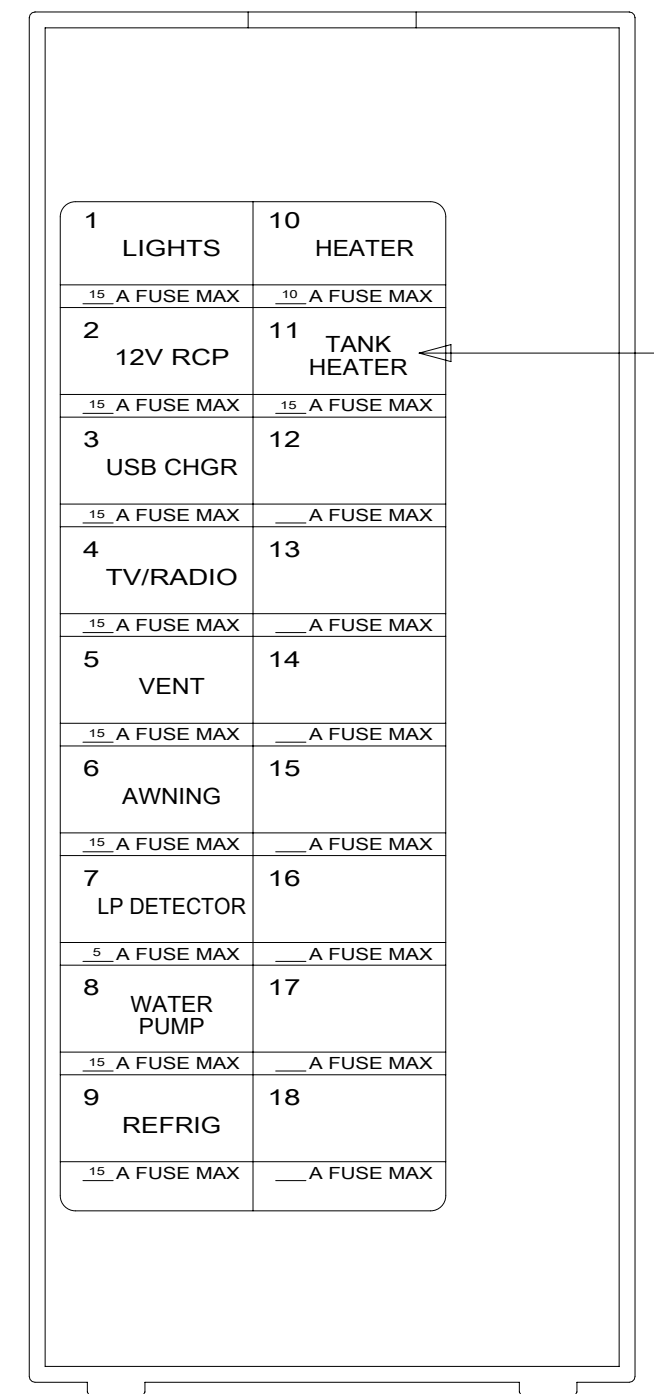
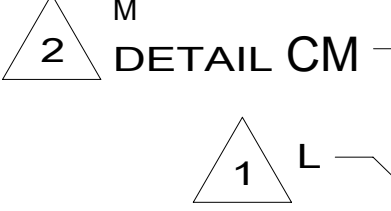

1 LIGHTS	10 HEATER
2 12V RCP	11 TANK HEATER
3 USB CHGR	12
4 TV/RADIO	13
5 VENT	14
6 AWNING	15
7 LP DETECTOR	16
8 WATER PUMP	17
9 REFRIG	18

23T
23R

DETAIL CM
(BACK SIDE
OF COVER)

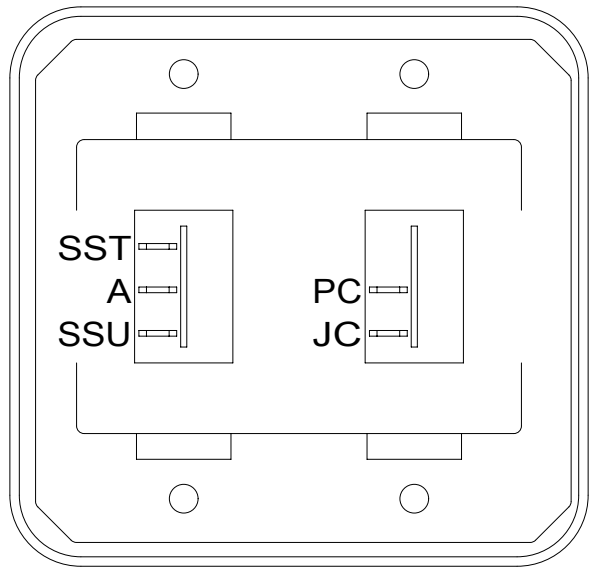

SWITCH-ROCKER
135740-01-CHT
135740-02-CHT
SWITCH-BASE
135741-02-CHT
SWITCH-BEZEL
135742-02-CHT
SCREW
G11-08-08U (4)

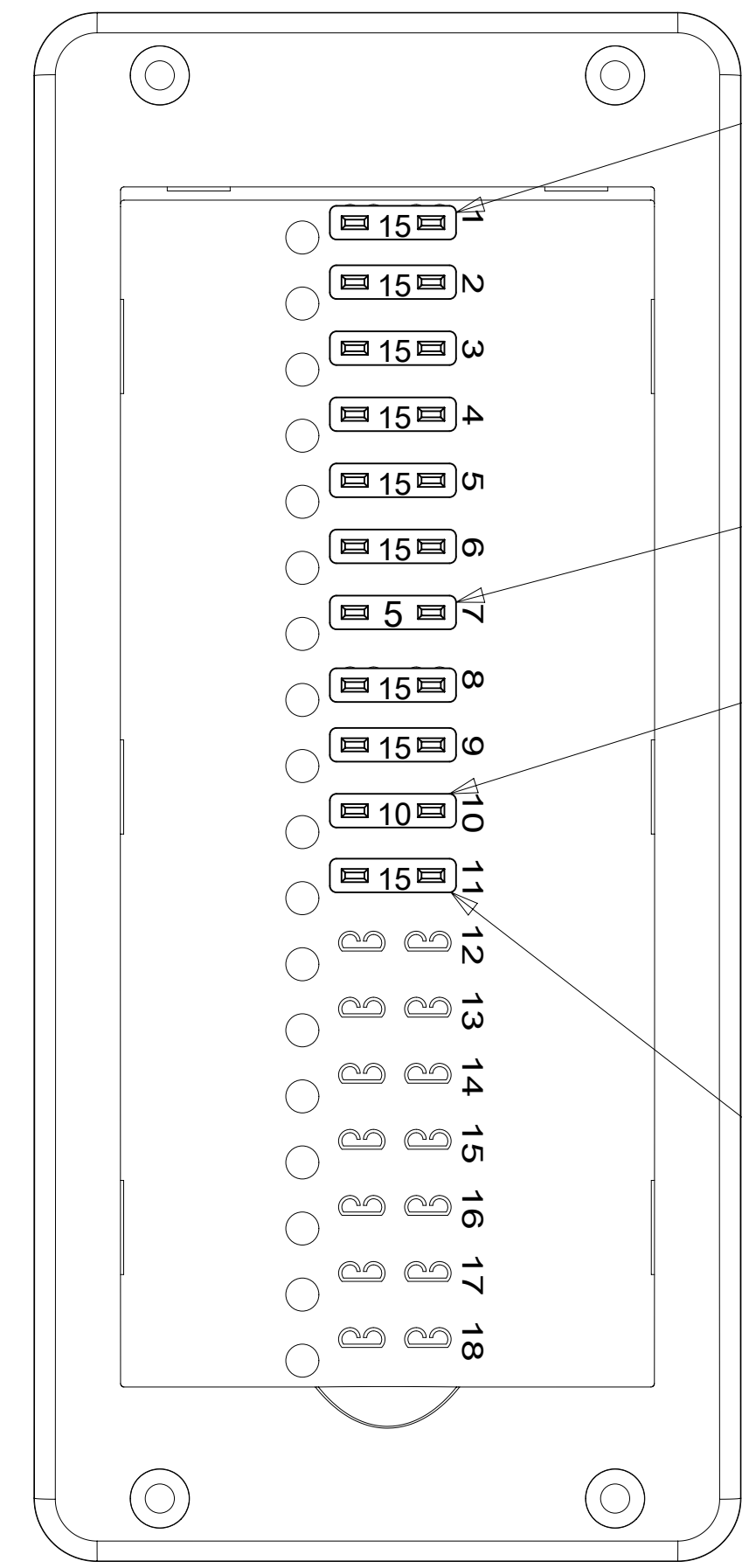

FUSE-15 AMP
062901-05-000 (8)

FUSE-5 AMP
062901-02-000

FUSE-10 AMP
062901-04-000

FUSE-15 AMP
062901-05-000

1 J

2 M

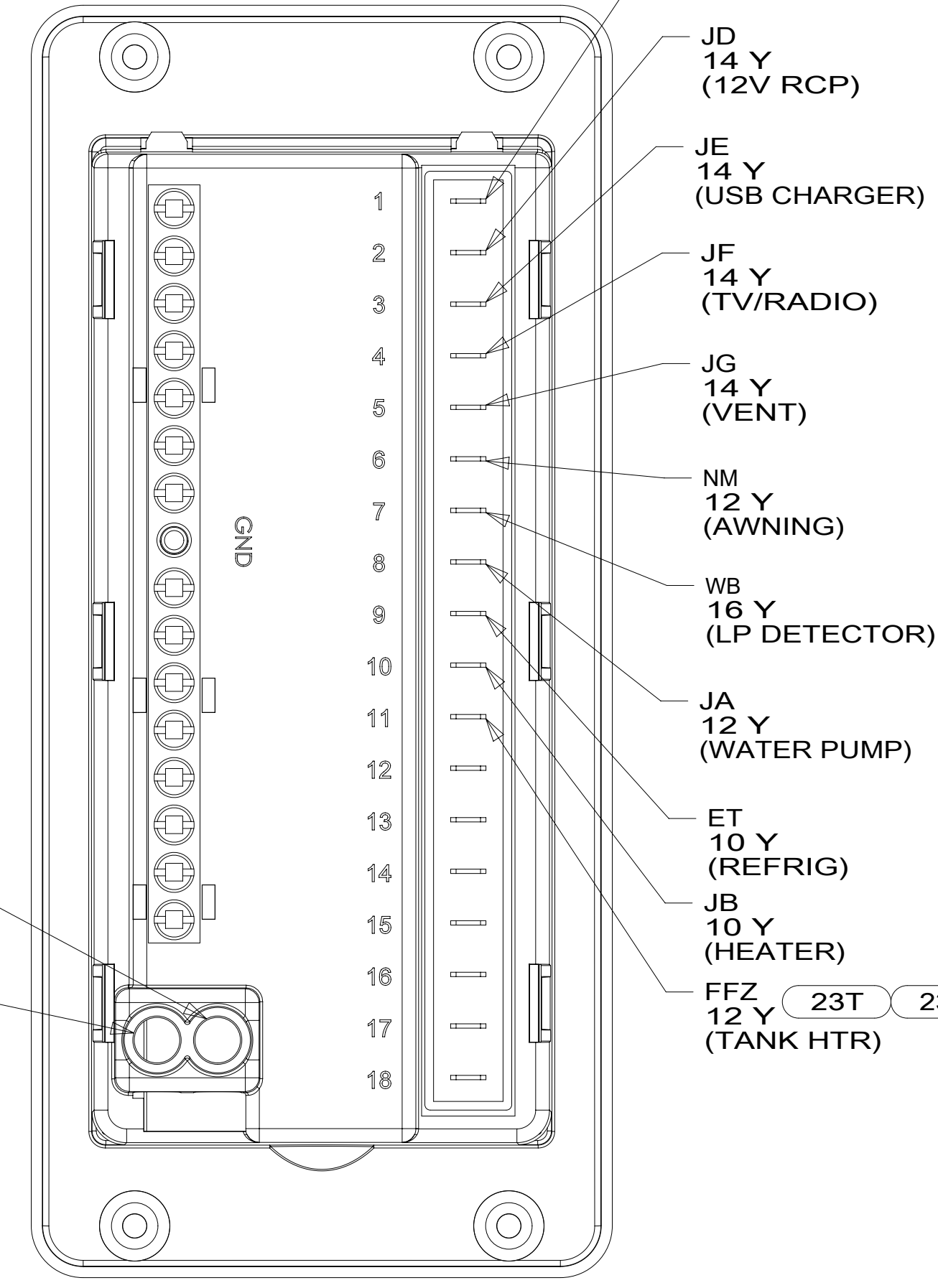

JC
14 Y
(LIGHTS)

JD
14 Y
(12V RCP)

JE
14 Y
(USB CHARGER)

JF
14 Y
(TV/RADIO)

JG
14 Y
(VENT)

NM
12 Y
(AWNING)

WB
16 Y
(LP DETECTOR)

JA
12 Y
(WATER PUMP)

ET
10 Y
(REFRIG)

JB
10 Y
(HEATER)

FFZ
12 Y
(TANK HTR)

- 1JD DRAINAGE SYSTEM-HEATED-W/O
- 23R DRAINAGE SYSTEM/HEAT-PREWIRE
- 07B RUNNING BOARDS - ALUMINUM
- 1E2 ENTRANCE STEP-ELEC.
- 23T DRAINAGE SYSTEM-HEATED
- 265 CODES/STANDARDS-CSA/CMVSS
- 1B1 CODES/STANDARDS USA

NOTES:
2 CIRCUIT FROM WIRE ASM-COACH.
1 CIRCUIT FROM WIRE ASM-CHASSIS.

FOR ELECTRICAL
TORQUE
SPECIFICATIONS
SEE DWG NO.
128783-01-000

FOR ELECTRICAL
CALLOUTS
SEE DWG NO.
121339-01-000

DESCRIPTION:
WIRING INSTL-BODY, 12V
SHEET: 3 OF 5 ITEM/PART NO: 000085020 / 32241501000 REV

PANEL-SOLAR 45 WATT
000169899 / 318635-02-CHT
MOUNTING FEET-SOLAR, QTY 4
000037645 / 318636-01-000
SCREW
G39-10-10U (12)
BRACKET-MOUNTING,SOLAR PANEL,ROOF RACK
000031343 / 316954-01-CHT (4)
BOLT
C27-05-16U (4)
WASHER
058716-07-000 (4)

RADIO ANENNA
TO RADIO COAX-BLU
TO ANTENNA PLATE

ANTENNA-RADIO
90944-01-000

WIRE ASM-SOLAR EXT
195056-01-000
CLAMP
10495-02-000 (4)

TO WIRE ASM-COACH

WIRE ASM-ROOF
000126853 / 324539-01-000
DETAIL DC

GROMMET
114208-04-000

TO EXTERIOR LAMP

TO SPEAKER

TO SPEAKER

TO AWNING
DETAIL ED

PORT-SOLAR, 3 POS
000170803 / 331218-01-CHT
SPACER
000041695 / 319875-01-CHT (2)
SCREW
G39-10-16U (4)
GROMMET
114208-05-000
DETAIL DD

TO REAR
PORCH LIGHT

TO BATH
VENT

LSH-2

PANEL-SOLAR 170 WATT
000041411 / 318634-02-CHT
MOUNTING FEET-SOLAR, QTY 4
000037645 / 318636-01-000
SCREW
G39-10-10U (12)
BRACKET-MOUNTING,SOLAR PANEL,
ROOF RACK
000031343 / 316954-01-CHT (4)
BOLT
000C27-05-16U (4)
WASHER
058716-07-000 (4)

LIGHT-LED,ROUND 3.5 PLASTIC
000166893 / 329928-01-CHT (4)

SCREW
G13-06-08U (12)
CONNECTOR
58028-01-000 (8)

PANEL-SUPPORT,ANTENNA
000167998 / 330247-01-CHT
SCREW
G39-08-12U (6)
SCREW
G39-08-10U (6)
GROMMET
114208-04-000 (2)

TO GALLEY
VENT

DETAIL EA

TO SERVICE LIGHT

CONNECT VENDOR RED WIRE TO
WINNEBAGO BLACK WIRE THAT
HAS RED TAPE

CONNECT VENDOR BLACK
WIRE TO WINNEBAGO
GREEN WIRE.

PORT-SOLAR
(REF)

DETAIL DD

ANTENNA-TV, OMNIDIRECTIONAL
000171487 / 331386-01-CHT
SCREW
G39-10-16U (4)

BRACKET-TV SWING MOUNT
179241-02-CHT
PAD-FELT 3/8
023320-01-000 (3)
(ADHERE TO RUBBER
BUMPERS ON BRACKET)
NUT-SERT
39715-01-000 (4)
BOLT
C26-04-12U (4)
WASHER
000E13-04-00U (6)
SEAL-FOAM TAPE
154585-07-CHT
(370 MM)

VIEW DA

VIEW DB

DB

WIRE
ASM-
ROOF

WIRE ASM-
ROOF

A

NOTES:

- 7 MOUNT SOLAR PANEL TO ROOF WITHOUT LUGGAGE RACK WITH LUGGAGE RACK
 - 6 USE BOLT,LOCK WASHER,AND NUT FROM MOUNT FEET -SOLAR 318636-01-000 DISCARD MOUNTING FEET AND USE THE BRACKET TO MOUNT THE SOLAR PANELS TO THE LUGGAGE RACK.
 - 5 ATTACH CLAMPS WHEN MOUNTING A/C PANEL. SEE A/C SYSTEM INSTL FOR ADDITIONAL INFORMATION.
 - 4 LOCATE HOLES TO MATCH PANEL-REAR,RH.
 - 3 MOUNTED ON INTERIOR SURFACE OF ROOF.
 - 2 MOUNTED ON EXTERIOR SURFACE OF ROOF.
1. AT MINIMUM ALL WIRES TO BE SUPPORTED AND SECURED PER CODE REQUIREMENTS. USE CLAMP 10495 OR 10497 OR WIRE TIE 8343 OR 108046 AND SCREW G67-XX-XXX OR G56-XX-XXX AS APPROPRIATE FOR INSTALLATION.

FOR ELECTRICAL
TORQUE
SPECIFICATIONS
SEE DWG NO.
128783-01-000

FOR
ELECTRICAL
CALLOUTS
SEE DWG NO.
121339-01-000

- LUGGAGE RACK
- CODES/STANDARDS-CSA/CMVSS
- CODES/STANDARDS USA

DESCRIPTION: WIRING INSTL-BODY,12V	
SHEET: 4 OF 5	ITEM/PART NO: 000085020 / 32241501000
REV	

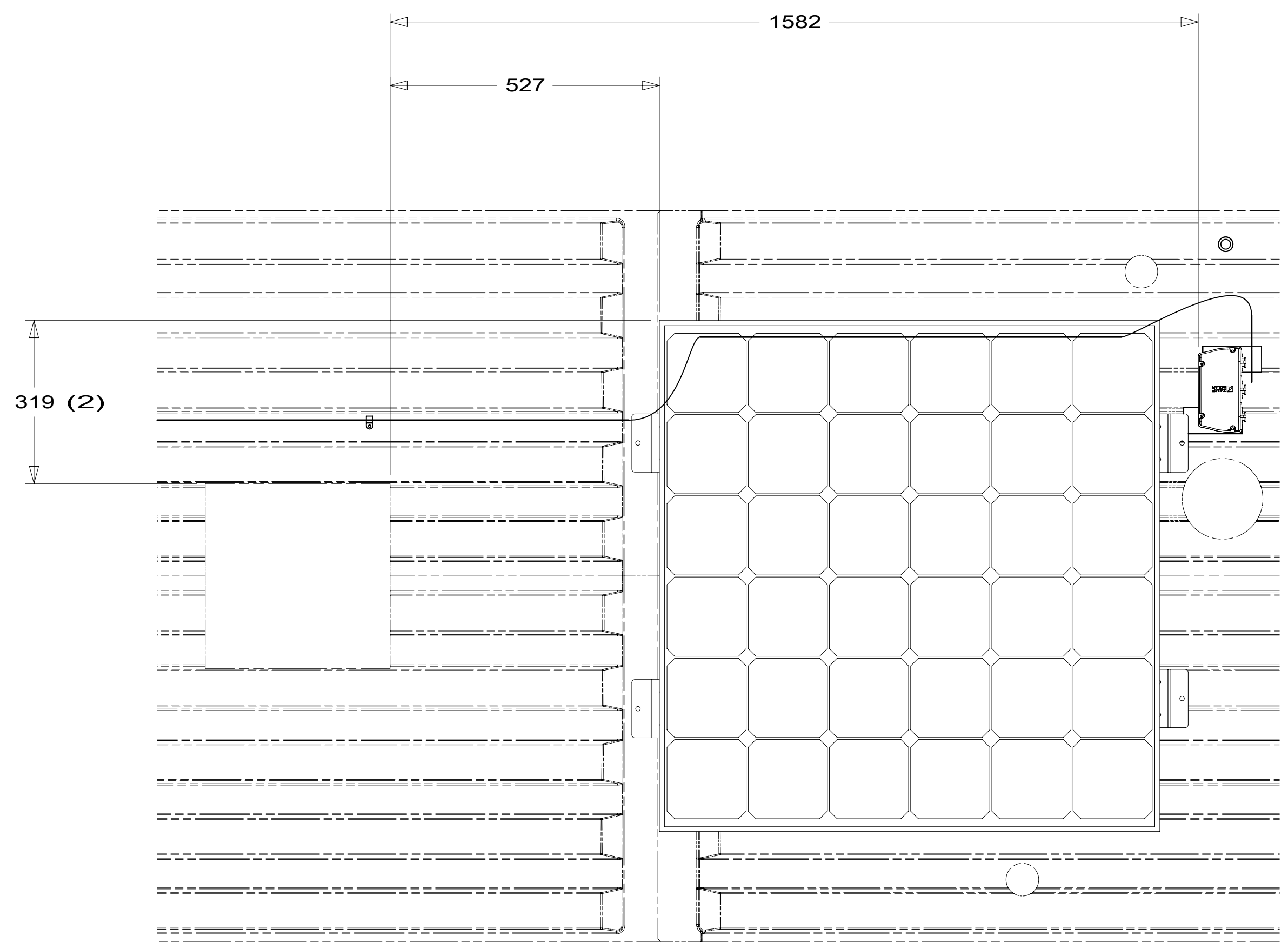

DETAIL EA

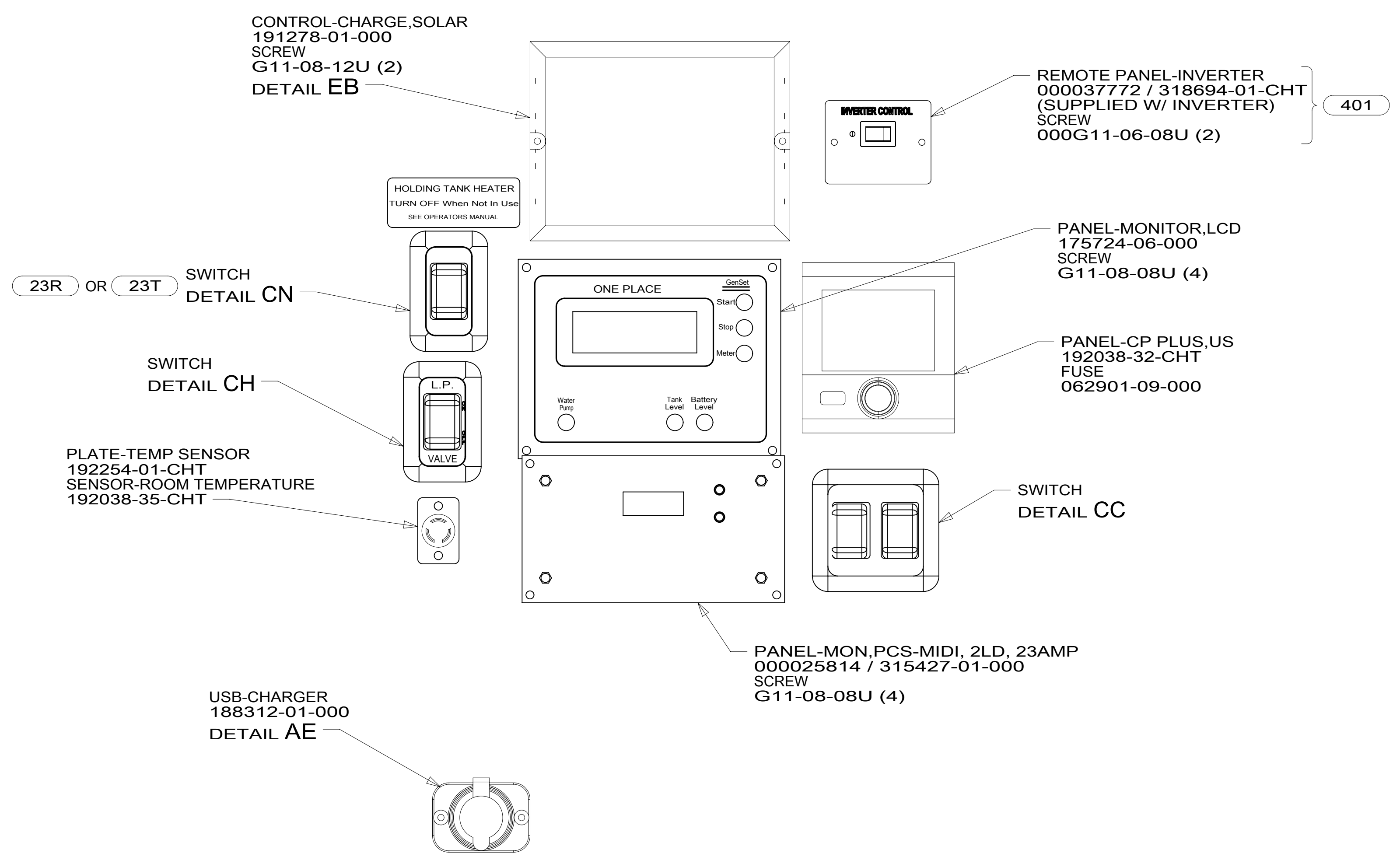

VIEW EC

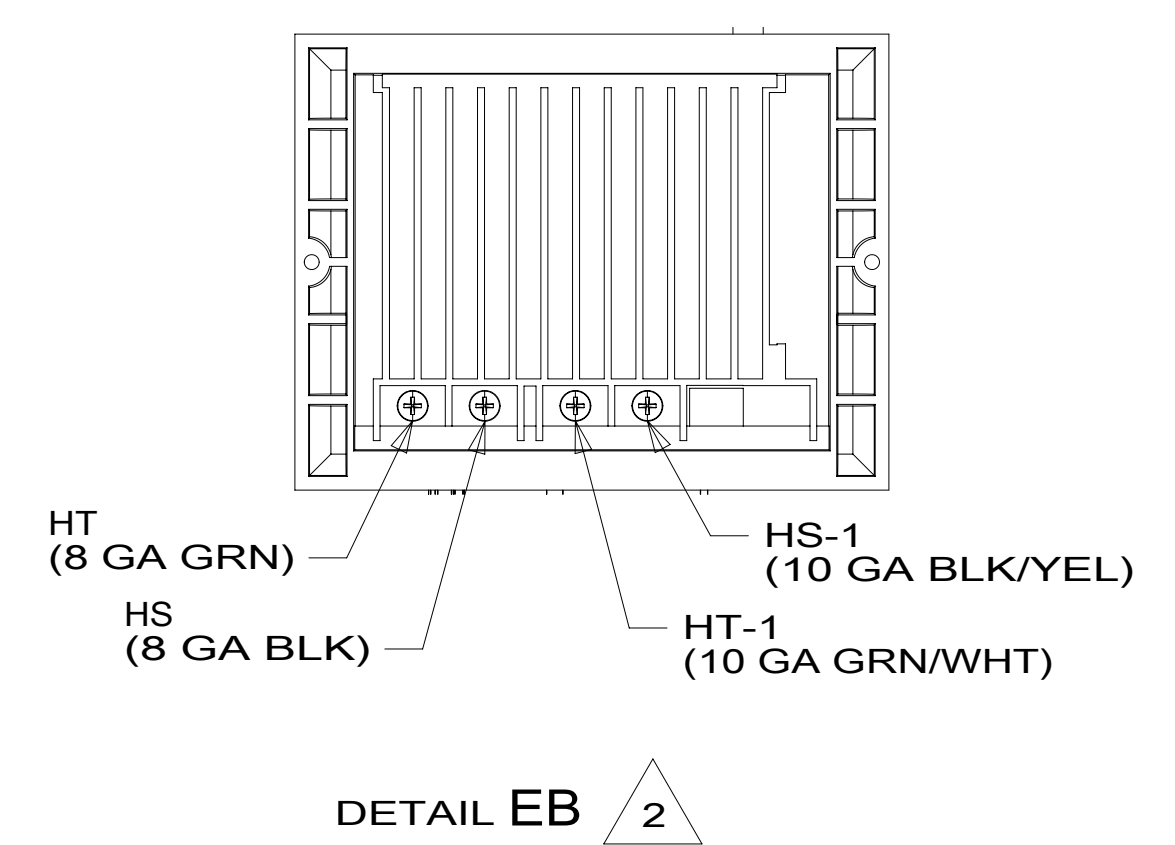

DETAIL EB 2

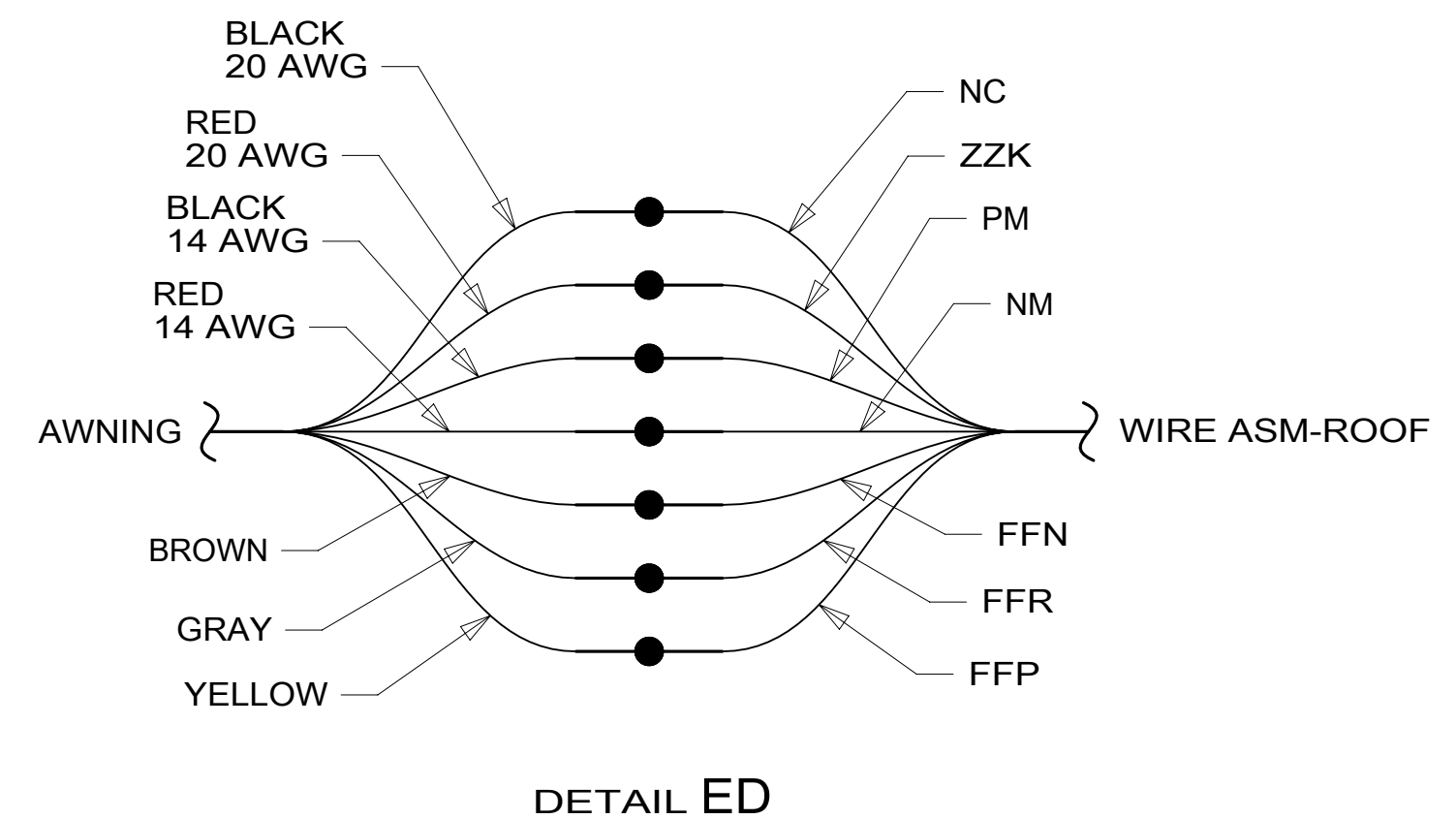

DETAIL ED

2 SEE WIRE ASM-SOLAR SYSTEM AND WIRE INSTL-CHASSIS FOR ADDITIONAL INFORMATION.

1. AT MINIMUM ALL WIRES TO BE SUPPORTED AND SECURED PER CODE REQUIREMENTS. USE CLAMP 10495 OR 10497 OR WIRE TIE 8343 OR 108046 AND SCREW G67-XX-XXX OR G56-XX-XXX AS APPROPRIATE FOR INSTALLATION.

NOTES:

- 23R DRAINAGE SYSTEM/HEAT-PREWIRE
- 401 INVERTER-DC/AC, 1000 WATT
- 23T DRAINAGE SYSTEM-HEATED
- 265 CODES/STANDARDS-CSA/CMVSS
- 1B1 CODES/STANDARDS USA

FOR ELECTRICAL TORQUE SPECIFICATIONS SEE DWG NO. 128783-01-000

FOR ELECTRICAL CALLOUTS SEE DWG NO. 121339-01-000

DESCRIPTION:		1B1 265	
WIRING INSTL-BODY, 12V			
SHEET:	ITEM/PART NO.:	REV	
5 OF 5	000085020 / 32241501000		