

- 9 REMOVE SWIVEL NUT ON TRAP-WATERLESS 165406-01-000, AND CONNECT P-6.
- 8 USE SMOOTH PLUMBERS PUTTY 167459-01-000 TO SEAL STRAINER (0.2 PER STRAINERS).
- 7 TRIM TO FIT.
- 6 VENT PIPE MUST PROJECT 51 MIN AND 64 MAX ABOVE ROOF FOR PROPER FIT AND FUNCTION.
- 5. SEAL AROUND SHOWER WITH SILICONE.
- 4. SECURE DRAINAGE PIPES TO CABINET USING WIRE TIE 108046-02-000, AND SCREW 000G67-10-12B AT INTERVALS OF NOT MORE THAN 4 FEET APART.
- 3. ALL PIPE AND FITTINGS TO BE ASSEMBLED WITH SOLVENT 004020-01-000 (USA), 004020-02-000 (CAN).
- 2. SLOPE OF TRAP ARM MUST BE 6 PER 305 mm.
- 1. SLOPE OF HORIZONTAL PIPING TO BE MINIMUM OF 3 PER 305 mm.

NOTES:

- 265 CODES/STANDARDS-CSA/CMVSS
- 1B1 CODES/STANDARDS USA



DSNR:		ALL DIMENSIONS ARE IN MILLIMETERS	
DIFFR:		MATERIAL:	
UNSPECIFIED TOLERANCES:			
WHOLE DIM (X)	3		
ONE-PLACE (X.X)	1.5		
TWO-PLACE (X.XX)	0.50		
ANGLE	1°		
REFER TO ES0018 FOR FASTENER TIGHTENING GUIDELINES		WEIGHT: (LBS)	FIRST USED: (REF)
			17 170M
<b>DESCRIPTION:</b>			
<b>DRAINAGE SYSTEM INSTL</b>			
SHEET:	ITEM/PART NO.:	REV	
1 OF 4	000214233 / 30354201000		

X-X  
FOR DRAINAGE CALLOUTS SEE DWG NO 116229-01-000

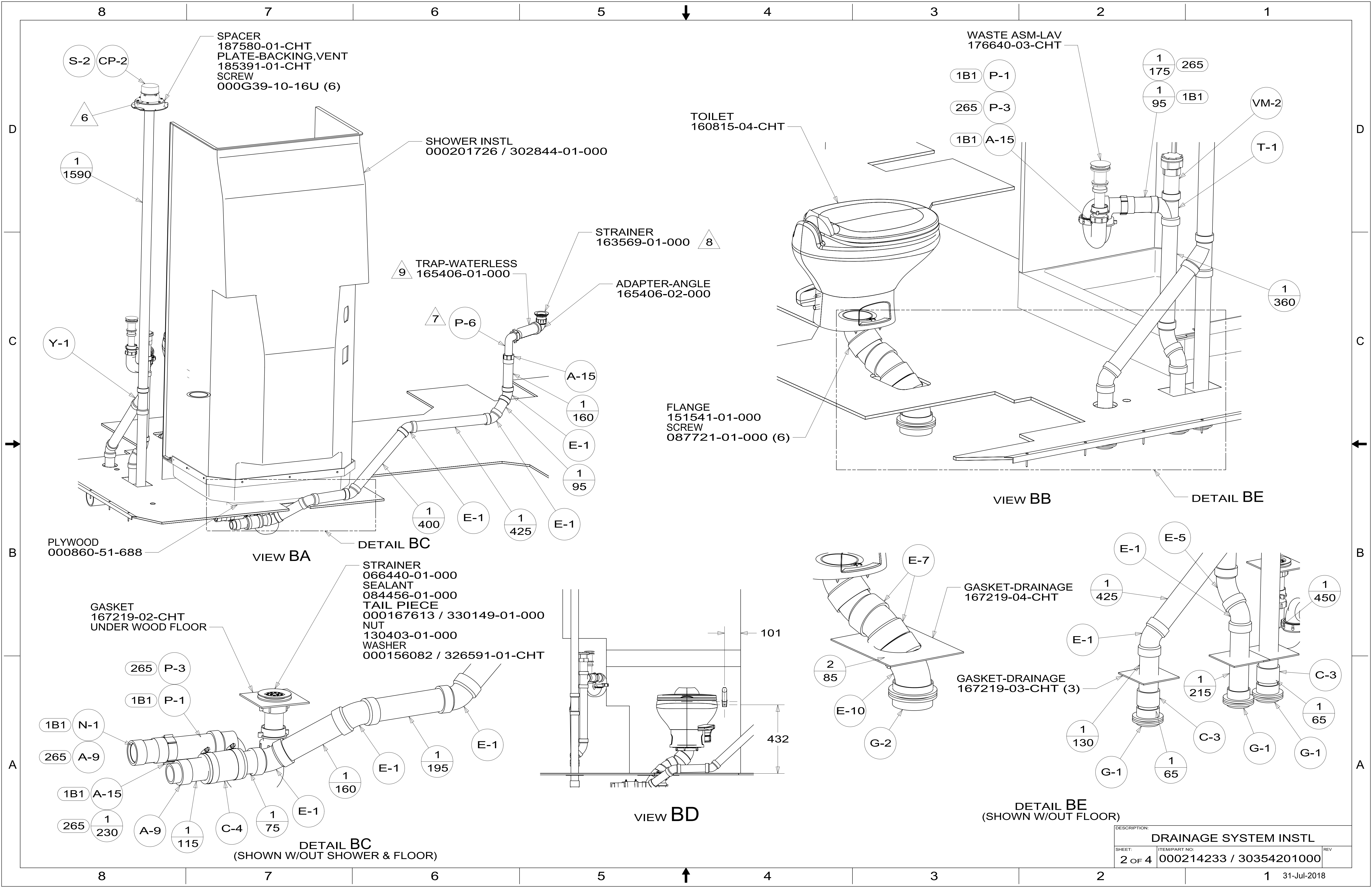

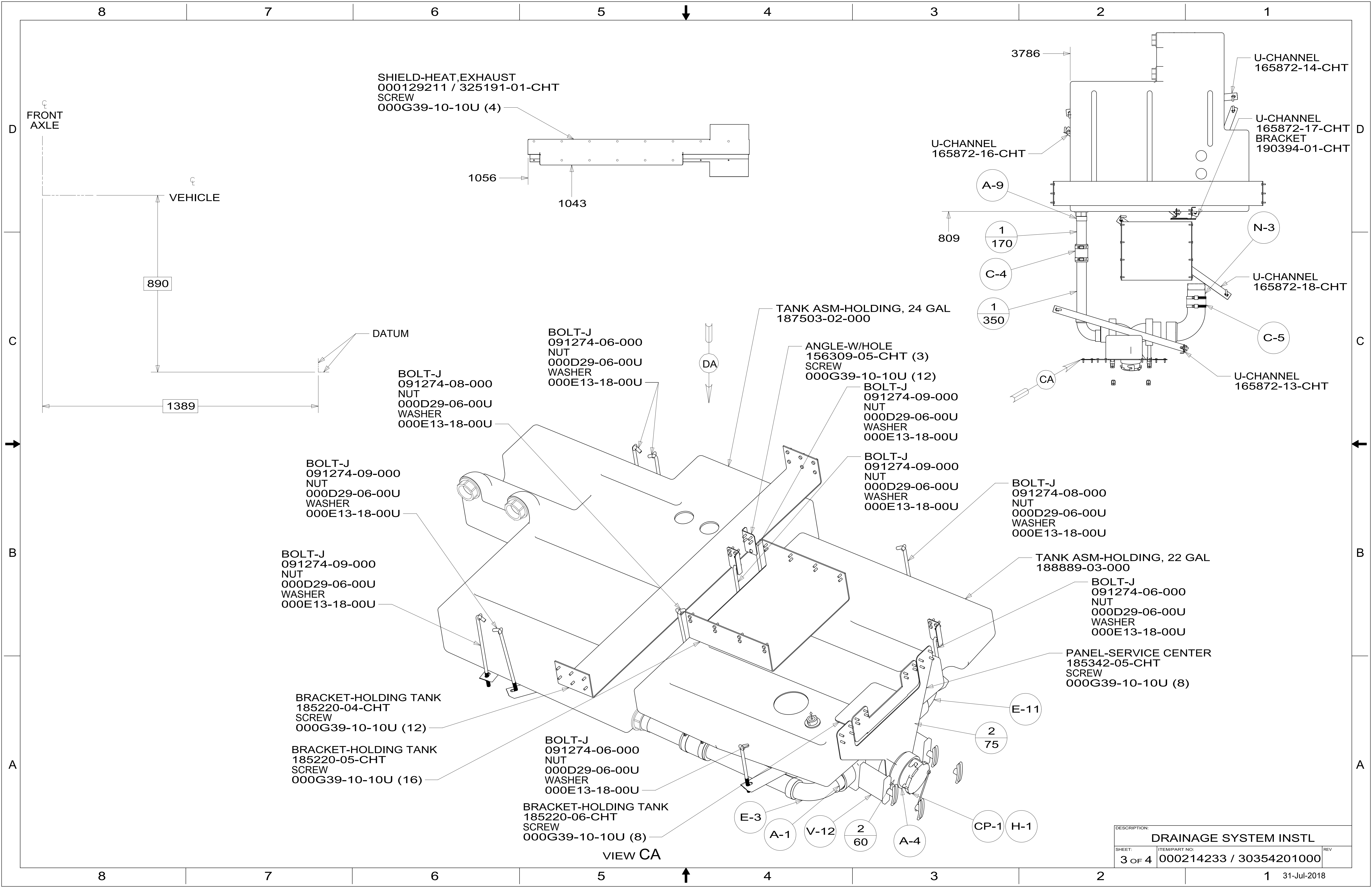

SHIELD-HEAT, EXHAUST  
 000129211 / 325191-01-CHT  
 SCREW  
 000G39-10-10U (4)

1056  
 1043

U-CHANNEL  
 165872-16-CHT

U-CHANNEL  
 165872-14-CHT

U-CHANNEL  
 165872-17-CHT  
 BRACKET  
 190394-01-CHT

FRONT AXLE  
 VEHICLE

890

1389

DATUM

BOLT-J  
 091274-06-000  
 NUT  
 000D29-06-00U  
 WASHER  
 000E13-18-00U

BOLT-J  
 091274-08-000  
 NUT  
 000D29-06-00U  
 WASHER  
 000E13-18-00U

TANK ASM-HOLDING, 24 GAL  
 187503-02-000

ANGLE-W/HOLE  
 156309-05-CHT (3)  
 SCREW  
 000G39-10-10U (12)

BOLT-J  
 091274-09-000  
 NUT  
 000D29-06-00U  
 WASHER  
 000E13-18-00U

BOLT-J  
 091274-09-000  
 NUT  
 000D29-06-00U  
 WASHER  
 000E13-18-00U

BOLT-J  
 091274-08-000  
 NUT  
 000D29-06-00U  
 WASHER  
 000E13-18-00U

TANK ASM-HOLDING, 22 GAL  
 188889-03-000

BOLT-J  
 091274-06-000  
 NUT  
 000D29-06-00U  
 WASHER  
 000E13-18-00U

PANEL-SERVICE CENTER  
 185342-05-CHT  
 SCREW  
 000G39-10-10U (8)

BOLT-J  
 091274-09-000  
 NUT  
 000D29-06-00U  
 WASHER  
 000E13-18-00U

BOLT-J  
 091274-09-000  
 NUT  
 000D29-06-00U  
 WASHER  
 000E13-18-00U

BRACKET-HOLDING TANK  
 185220-04-CHT  
 SCREW  
 000G39-10-10U (12)

BRACKET-HOLDING TANK  
 185220-05-CHT  
 SCREW  
 000G39-10-10U (16)

BOLT-J  
 091274-06-000  
 NUT  
 000D29-06-00U  
 WASHER  
 000E13-18-00U

BRACKET-HOLDING TANK  
 185220-06-CHT  
 SCREW  
 000G39-10-10U (8)

A-9

1  
 170

C-4

1  
 350

N-3

U-CHANNEL  
 165872-18-CHT

C-5

U-CHANNEL  
 165872-13-CHT

CA

809

BRACKET-HOLDING TANK  
 185220-04-CHT  
 SCREW  
 000G39-10-10U (12)

BRACKET-HOLDING TANK  
 185220-05-CHT  
 SCREW  
 000G39-10-10U (16)

BOLT-J  
 091274-06-000  
 NUT  
 000D29-06-00U  
 WASHER  
 000E13-18-00U

BRACKET-HOLDING TANK  
 185220-06-CHT  
 SCREW  
 000G39-10-10U (8)

E-11

2  
 75

E-3

A-1

V-12

2  
 60

A-4

CP-1

H-1

VIEW CA

DESCRIPTION:		
DRAINAGE SYSTEM INSTL		
SHEET:	ITEM/PART NO:	REV
3 OF 4	000214233 / 30354201000	

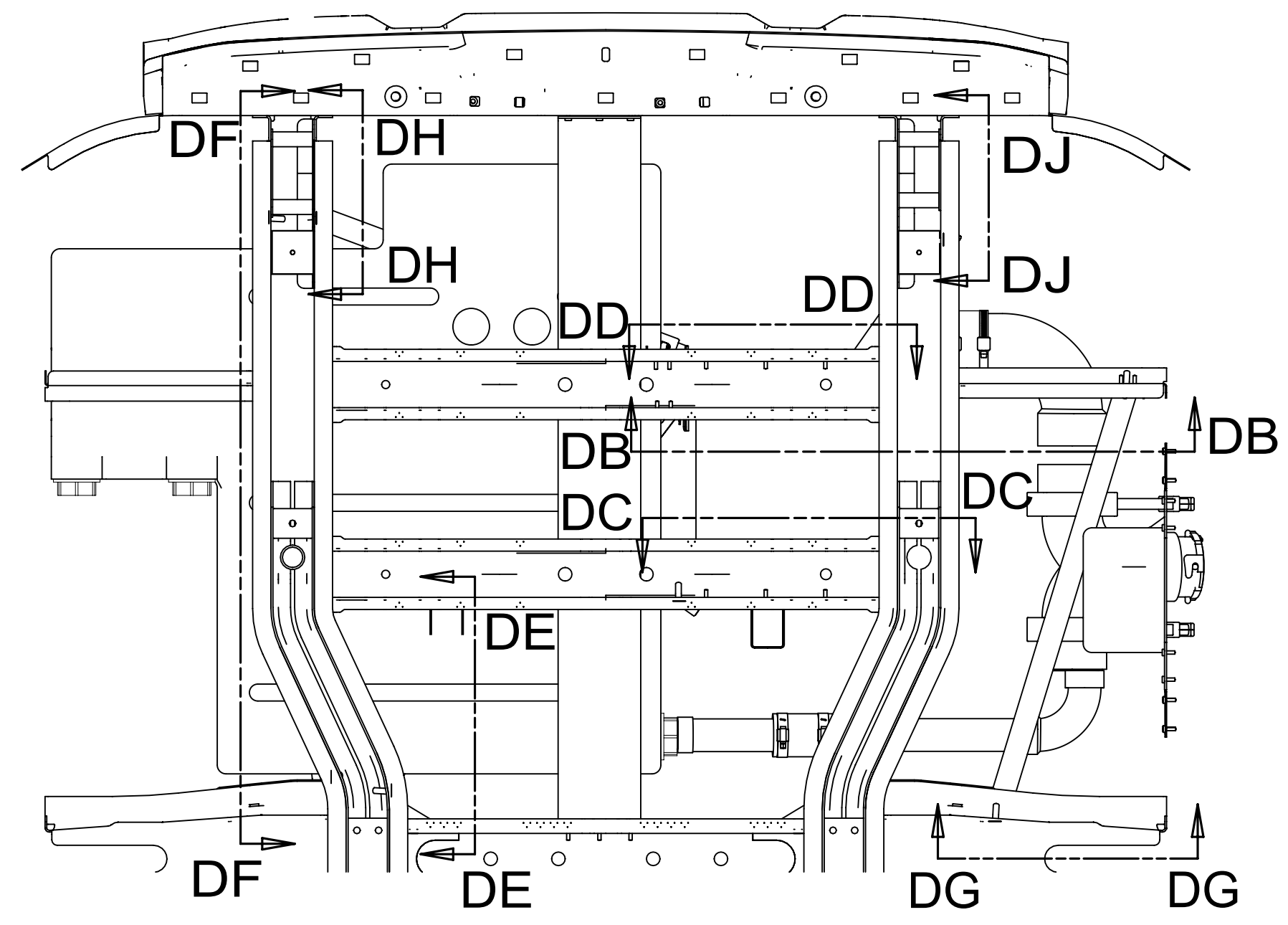

VIEW DA

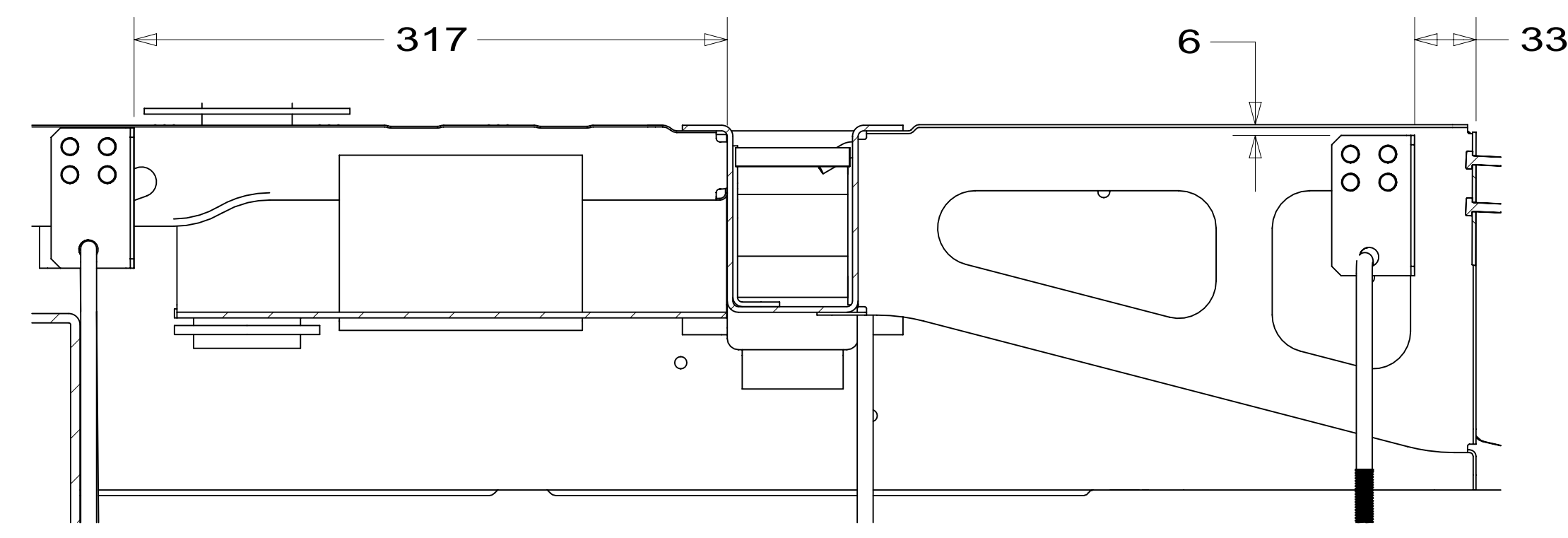

SECTION DB-DB

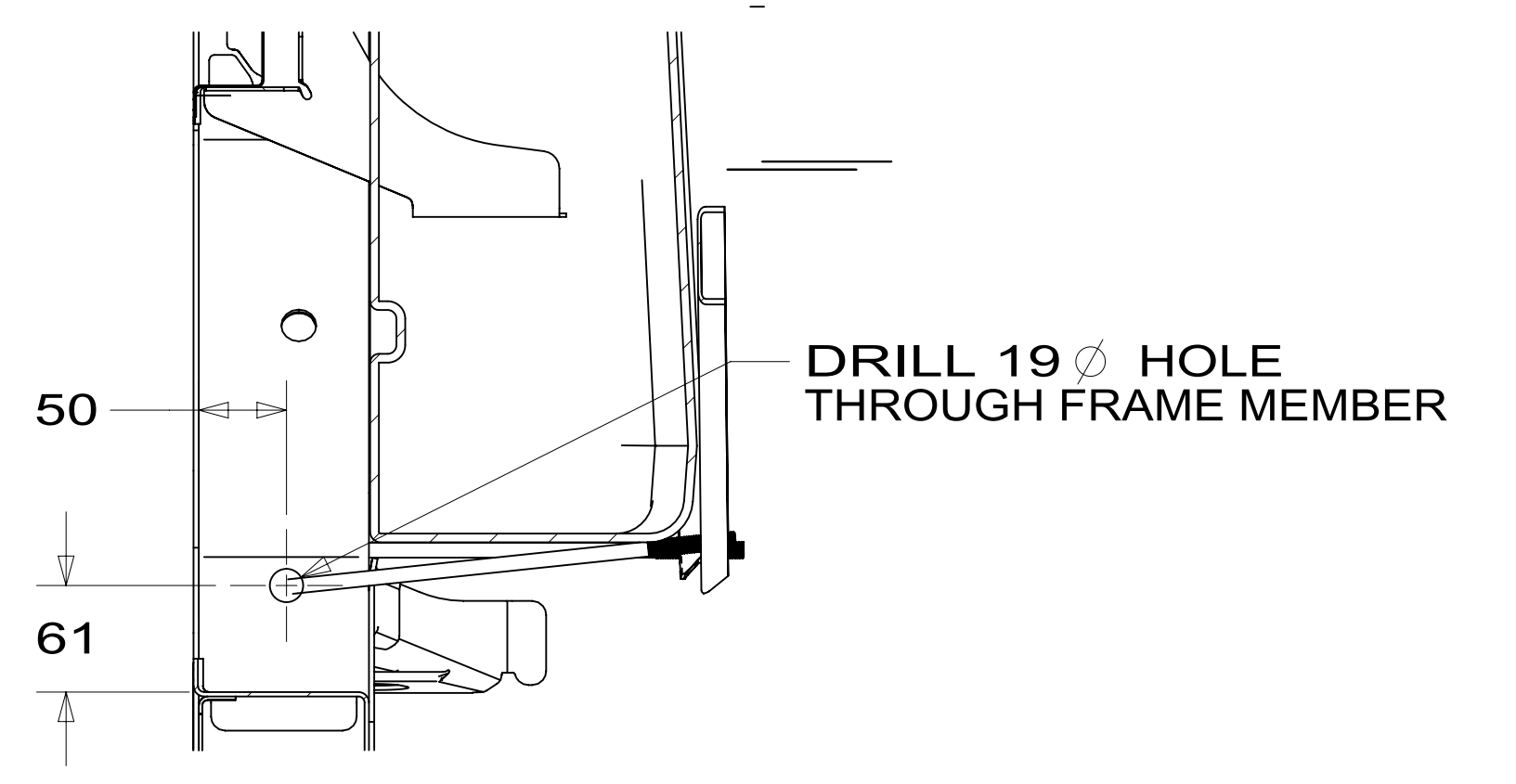

SECTION DE-DE

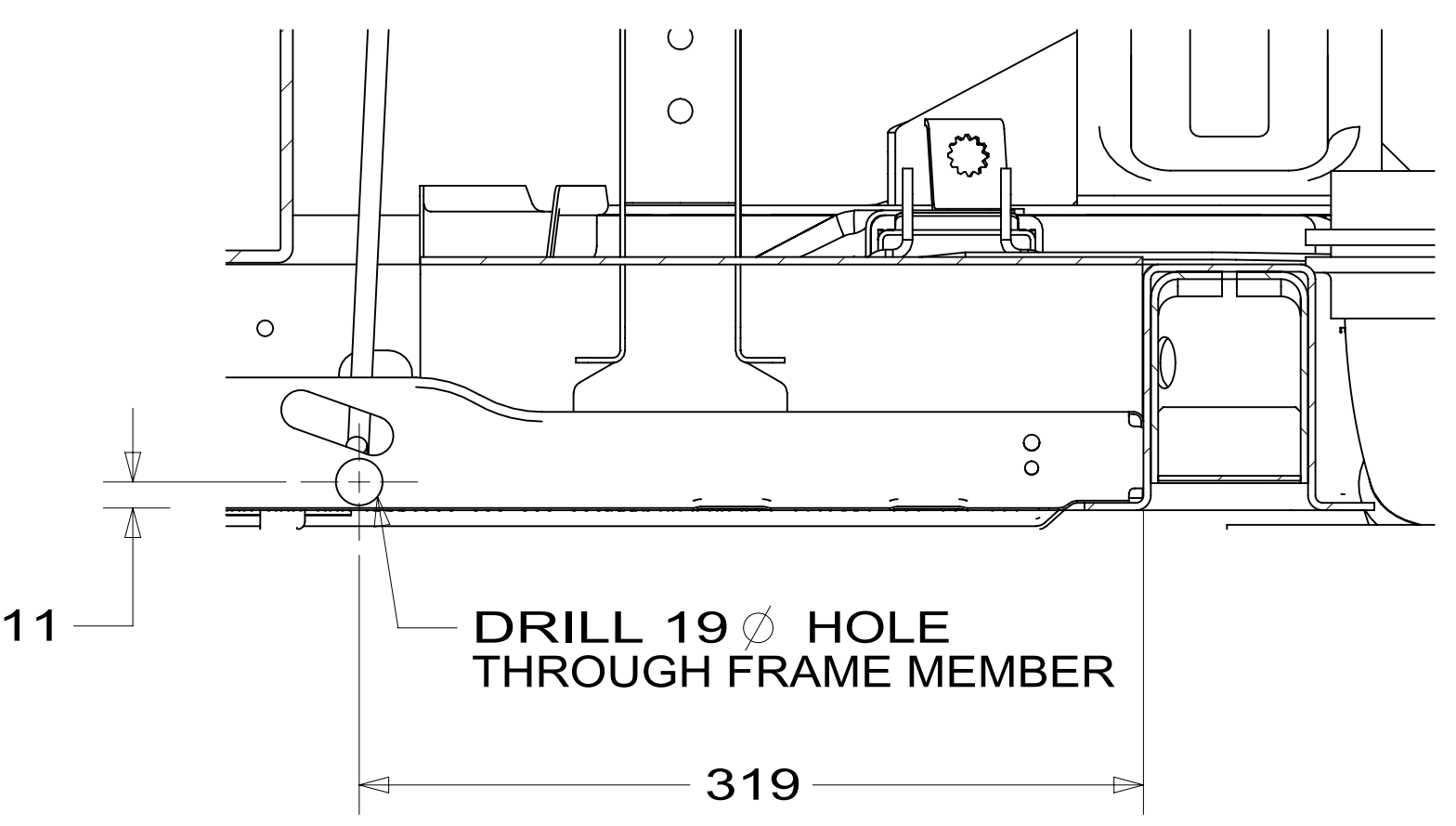

SECTION DC-DC

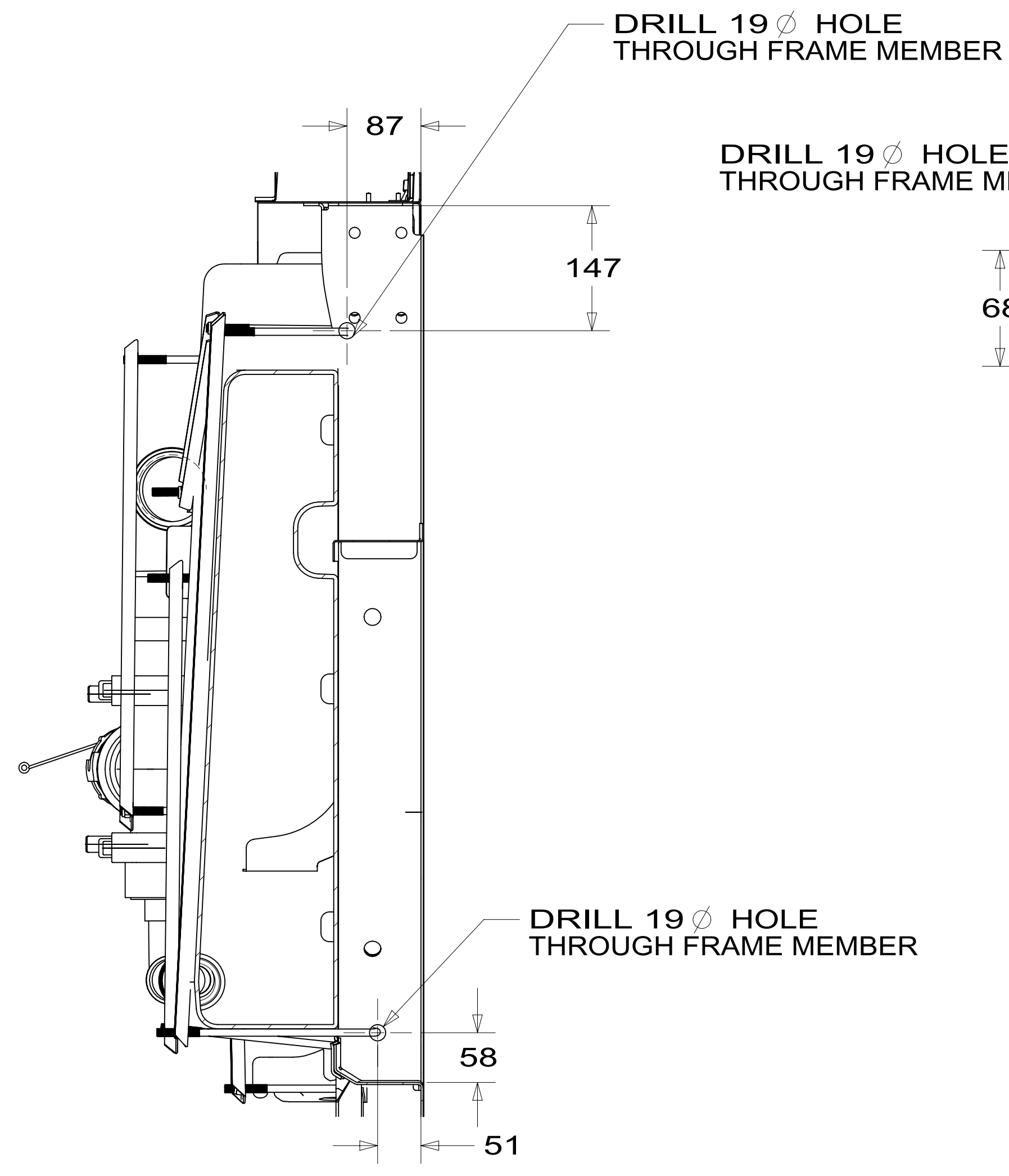

SECTION DF-DF

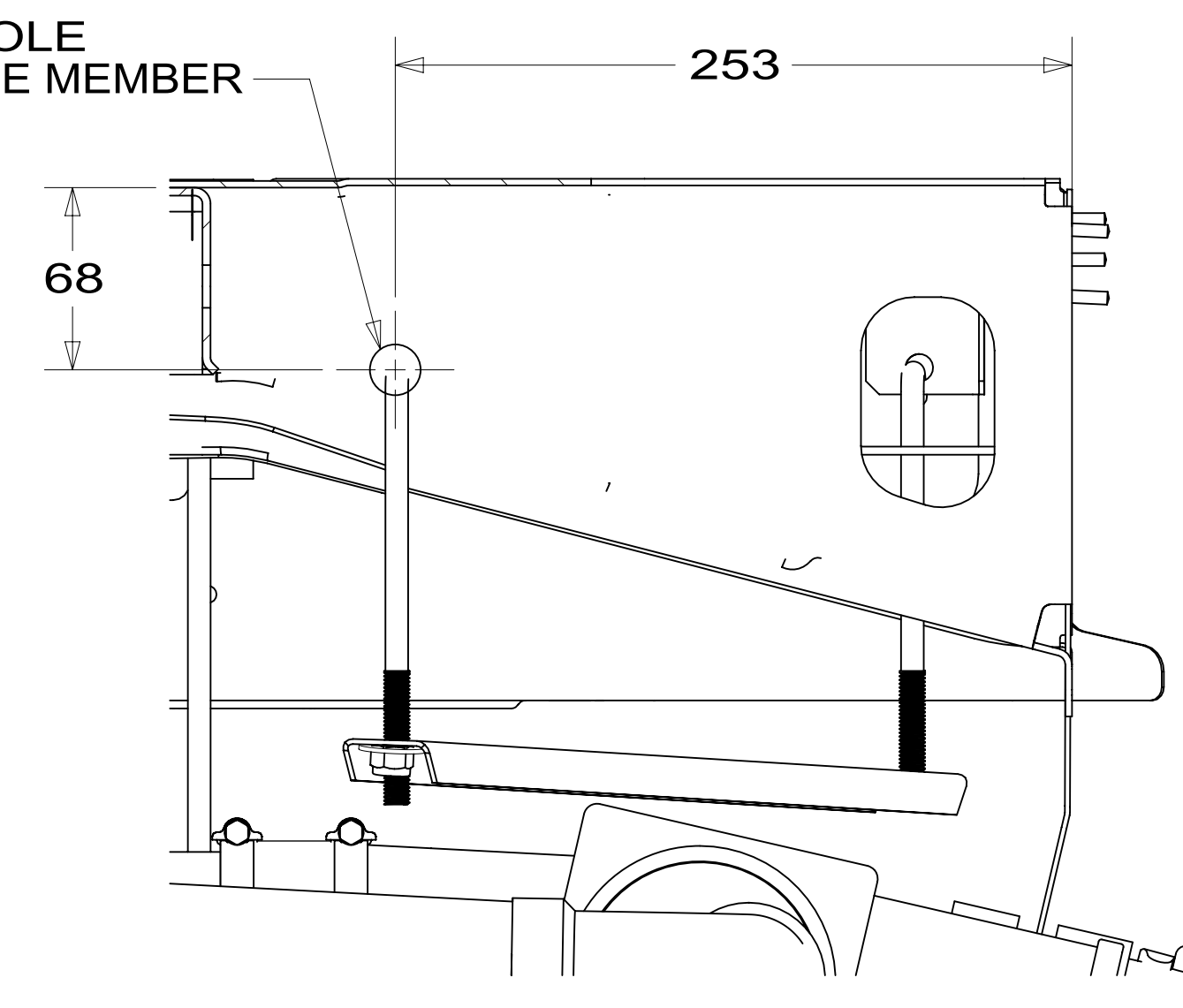

SECTION DG-DG

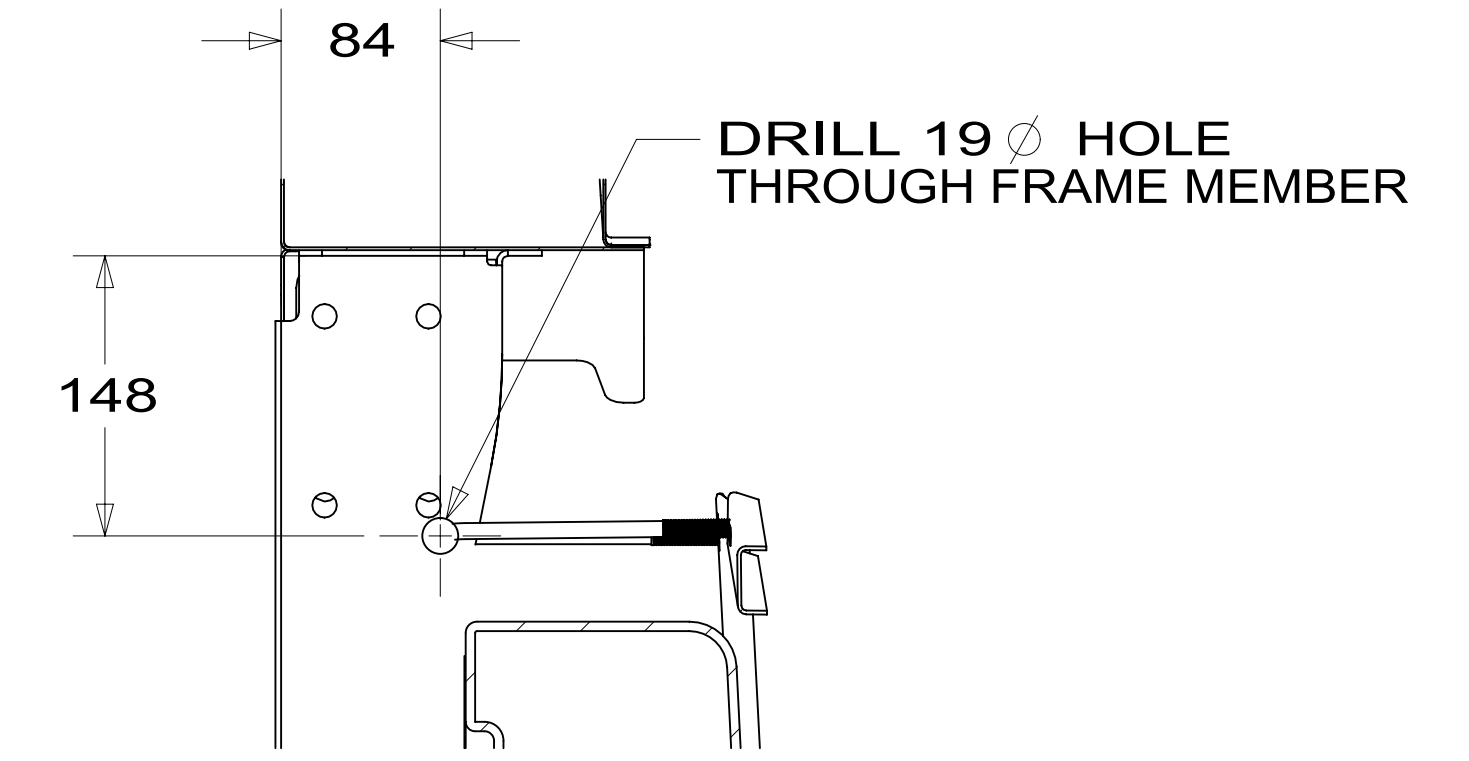

SECTION DH-DH

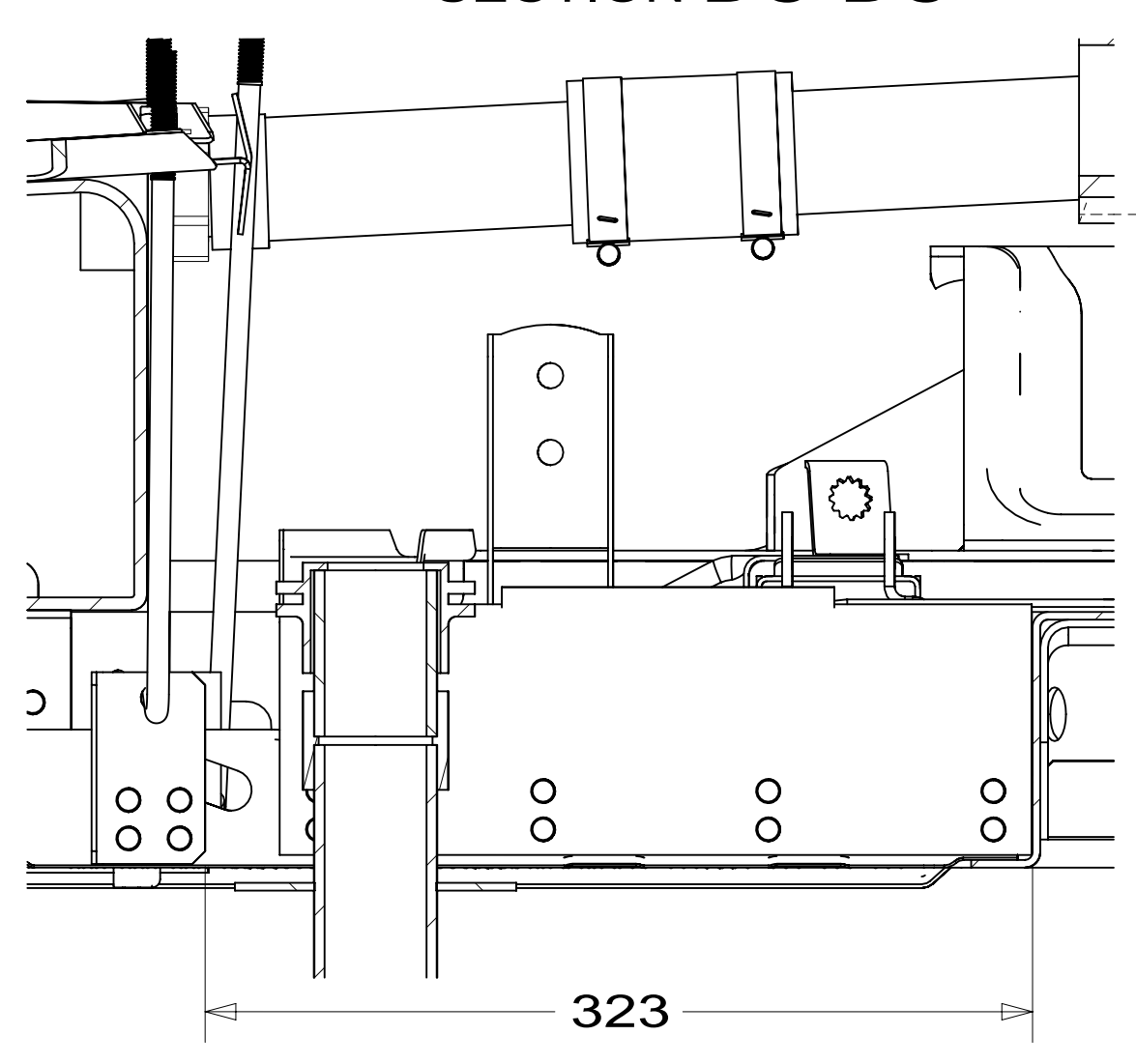

SECTION DD-DD

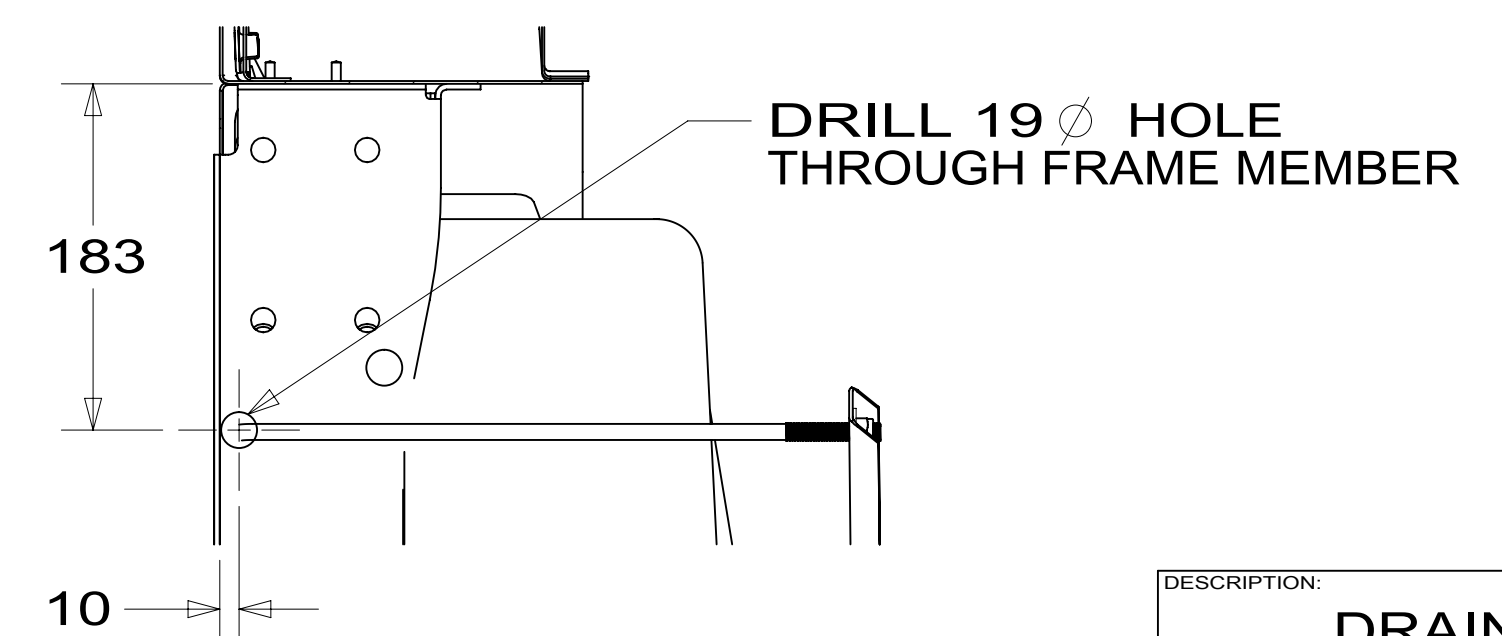

SECTION DJ-DJ

DESCRIPTION:		
DRAINAGE SYSTEM INSTL		
SHEET:	ITEM/PART NO.:	REV
4 OF 4	000214233 / 30354201000	