

- NOTES:**
1. AT MINIMUM ALL WIRES TO BE SUPPORTED AND SECURED PER CODE REQUIREMENTS. USE CLAMP 10495 OR 10497 OR WIRE TIE 8343 OR 108046 AND SCREW G67-XX-XXX OR G56-XX-XXX AS APPROPRIATE FOR INSTALLATION.
 2. ROUTE TANK SENSOR WIRES SO THEY DO NOT PASS OVER SENSORS. USE WIRE TIE MOUNT 155366-01-000 AND WIRE TIE 8343-01-000 AS NEEDED. TANK SURFACE MUST BE CLEANED USING ISOPROPYL ALCOHOL AND PRIMED WITH PRIMER 94.

- 4 PLACE CROSS LOCATOR ON SENSORS OVER DIMPLES ON TANK.
- 3 WIRE PASSES THROUGH FLOOR IN THIS AREA.

- 299 ENTERTAINMENT CENTER EXT.W/O
- 1DF EXT TV ENTERTAINMENT CENTER
- 265 CODES/STANDARDS-CSA/CMVSS
- 1B1 CODES/STANDARDS USA

WINNEBAGO
COPYRIGHT 2016 WINNEBAGO INDUSTRIES, INC.

DSNR:	ALL DIMENSIONS ARE IN MILLIMETERS
DFFR:	
UNSPECIFIED TOLERANCES:	MATERIAL:
WHOLE DIM (X) : 3	
ONE-PLACE (X.X) : 1.5	
TWO-PLACE (X.XX) : 0.50	
ANGLE : 1°	
REFER TO ES0018 FOR FASTENER TIGHTENING GUIDELINES	WEIGHT: (LBS) FIRST USED: 18 E32YE
DESCRIPTION: WIRING INSTL-BODY, 12V	
SHEET: 1 OF 7	ITEM/PART NO: 000131232 / 32567301000
REF:	1 12-Jan-2018

FOR ELECTRICAL TORQUE SPECIFICATIONS SEE DWG NO. 128783-01-000

FOR ELECTRICAL CALLOUTS SEE DWG NO. 121339-01-000

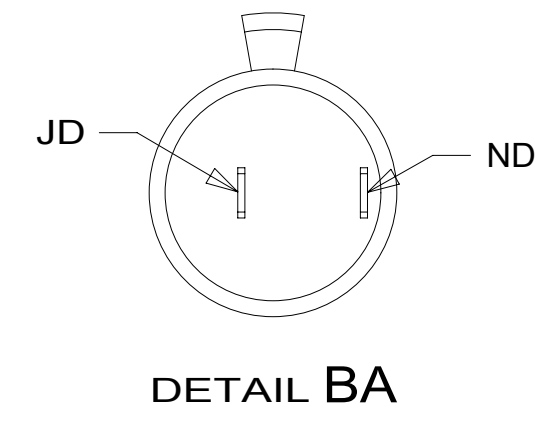
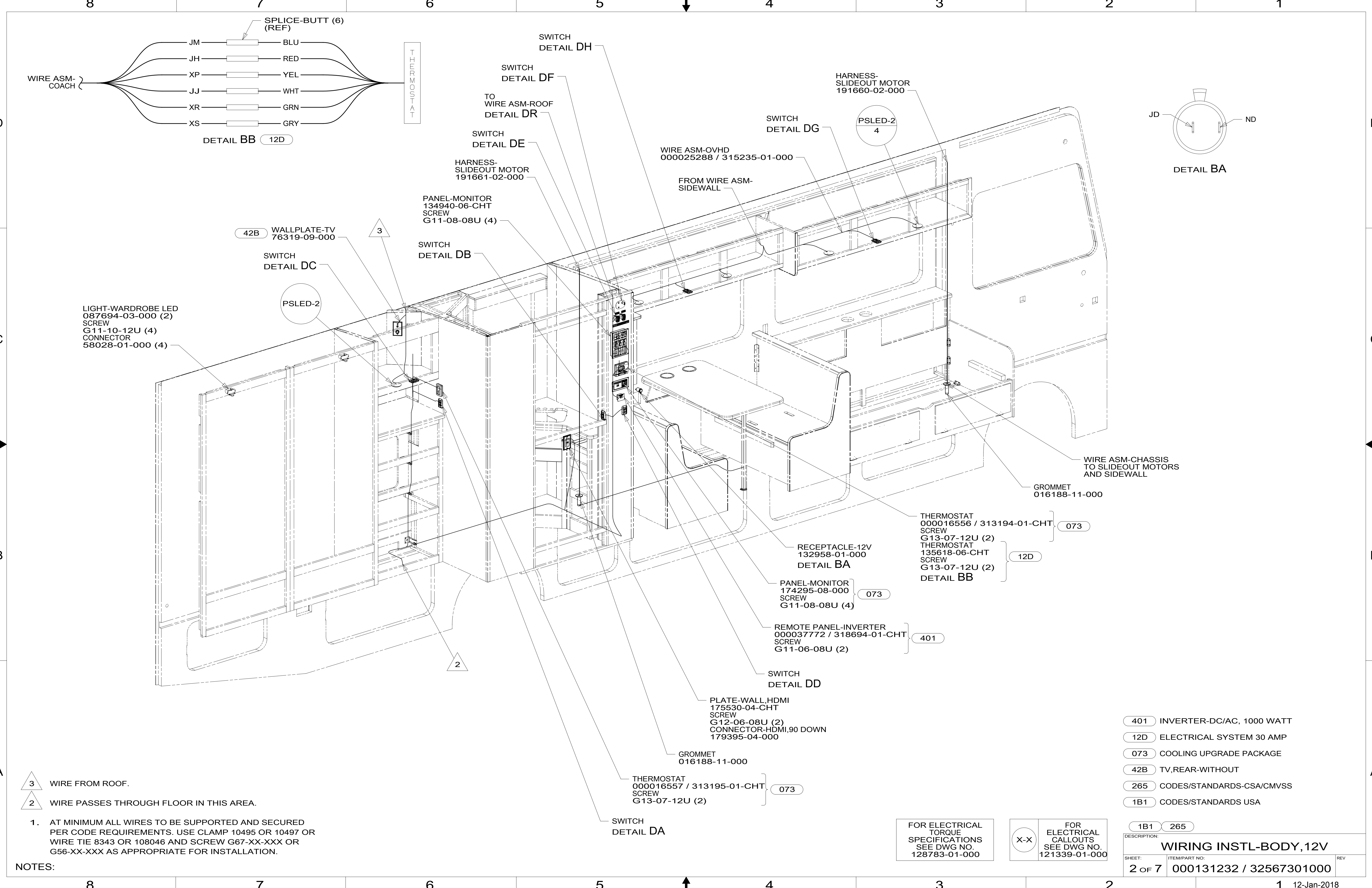
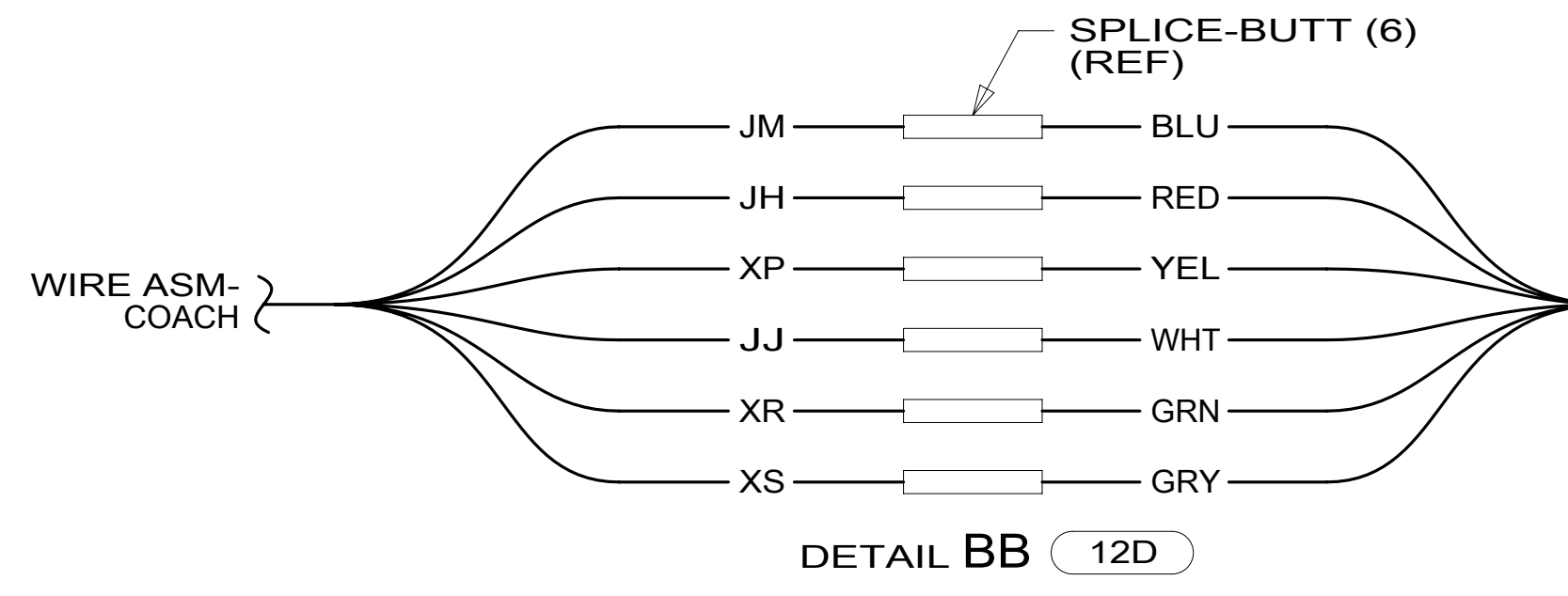

- 3 WIRE FROM ROOF.
- 2 WIRE PASSES THROUGH FLOOR IN THIS AREA.

1. AT MINIMUM ALL WIRES TO BE SUPPORTED AND SECURED PER CODE REQUIREMENTS. USE CLAMP 10495 OR 10497 OR WIRE TIE 8343 OR 108046 AND SCREW G67-XX-XXX OR G56-XX-XXX AS APPROPRIATE FOR INSTALLATION.

NOTES:

- 401 INVERTER-DC/AC, 1000 WATT
- 12D ELECTRICAL SYSTEM 30 AMP
- 073 COOLING UPGRADE PACKAGE
- 42B TV,REAR-WITHOUT
- 265 CODES/STANDARDS-CSA/CMVSS
- 1B1 CODES/STANDARDS USA

FOR ELECTRICAL TORQUE SPECIFICATIONS SEE DWG NO. 128783-01-000

FOR ELECTRICAL CALLOUTS SEE DWG NO. 121339-01-000

DESCRIPTION:	1B1 265	
WIRING INSTL-BODY, 12V		
SHEET:	ITEM/PART NO.:	REV:
2 OF 7	000131232 / 32567301000	

NEGATIVE BAR
140031-01-CHT
BOLT
C26-06-12U (5)
NUT
D39-06-00U (5)
STUD-ISOLATED
86233-01-000 (2)
NUT
D34-06-00U (2)
SCREW
G67-10-12U (4)

DETAIL CC

CONNECT ALL
GROUNDS TO
GROUND BAR

SWITCHES
DETAIL DL

073 12V BREAKER PANEL
DETAIL EB

SWITCH
DETAIL DM

12D 12V FUSES
DETAIL ED

SWITCHES
DETAIL DN

5 CONTROL CENTER-55A
(REF)

STEP SWITCH
DETAIL CA

LCS-1

AWNING-RELAY
63912-02-000
SCREW
G11-08-08U

1DF AMPLIFIER-STEREO
2 CHANNEL
147139-03-000
RELAY-RADIO-TV
SPEAKER SWITCH
115539-01-000

JW, JU & JX
TO WATER
HEATER
DETAIL CB

GROUND BAR
DETAIL CC

STUD-ISOLATED
86233-01-000
NUT
D34-06-00U
SCREW
G67-10-12U (2)
BOOT
77479-02-000

073 CONVERTER-45 AMP
184353-01-000
SCREW
G11-08-12U (3)
DETAIL EA

SPEAKER
171547-01-CHT (2)
SCREW
G39-10-12U (8)

1DF 6

PSLED-2
2

SWITCHES
DETAIL DK

LED-2

6. 3-PIN HOUSINGS
TO WIRE ASM-
SIDEWALL

ET, EU
TO REFRIGERATOR

GROMMET
108505-01-000

HARNESS-
SLIDEOUT MOTOR
191661-02-000

WIRE ASM-OVHD
192894-01-000

SWITCH
DETAIL DJ

PSLED-2
2

HARNESS-
SLIDEOUT MOTOR
191661-01-000

LPGD

GROMMET
016188-11-000

CLAMP-CABLE
10495-01-000 (2)
SCREW
G67-10-12U (2)

GROMMET
016188-11-000

7 WASHER-LOCK
000007554 / 310611-01-000 (2)

ROUTE WIRES
THRU HOLE

GROMMET
8386-01-000

JAMB-DOOR

SWITCH/MAGNET-
STEP-ELECTRIC
116995-03-000
SCREW
G11-06-06U (2)

DETAIL CA

SPLICE-BUTT (3)
(REF)

WIRE ASM-
COACH

JW

RED

JU

BLU

JX

GRN

DETAIL CB

WATER

- 7 REMOVE SCREWS FROM MAGNET SWITCH TO INSTALL LOCK WASHER AND RING TERMINALS.
- 6 SPEAKER MOUNTED TO EXTERIOR SURFACE OF SIDEWALL.
- 5 SEE LOAD CENTER/ATS ASM FOR ADDITIONAL INFORMATION.
- 4 WIRE PASSES THROUGH FLOOR IN THIS AREA.
- 3 MOUNT MAGNET TO SCREEN DOOR FRAME, MOUNT WITH MAGNET TOWARD SWITCH.
- 2 MOUNT SWITCH TO DOOR JAMB WITH TAPE 076322-21-000.

1. AT MINIMUM ALL WIRES TO BE SUPPORTED AND SECURED PER CODE REQUIREMENTS. USE CLAMP 10495 OR 10497 OR WIRE TIE 8343 OR 108046 AND SCREW G67-XX-XXX OR G56-XX-XXX AS APPROPRIATE FOR INSTALLATION.

NOTES:

FOR ELECTRICAL
TORQUE
SPECIFICATIONS
SEE DWG NO.
128783-01-000

X-X

FOR ELECTRICAL
CALLOUTS
SEE DWG NO.
121339-01-000

- 12D ELECTRICAL SYSTEM 30 AMP
- 073 COOLING UPGRADE PACKAGE
- 1DF EXT TV ENTERTAINMENT CENTER
- 265 CODES/STANDARDS-CSA/CMVSS
- 1B1 CODES/STANDARDS USA

1B1 265

DESCRIPTION:
WIRING INSTL-BODY, 12V

SHEET: 3 OF 7 ITEM/PART NO: 000131232 / 32567301000 REV

1 12-Jan-2018

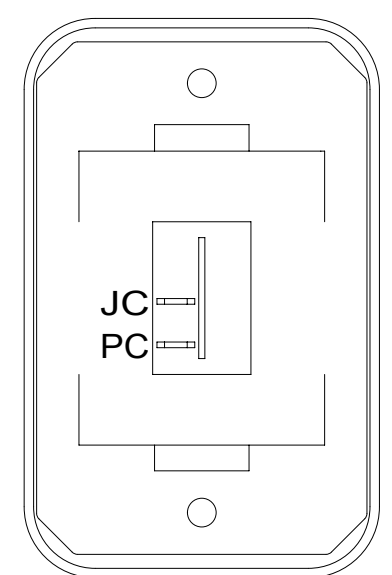

SWITCH-ROCKER
135740-01-CHT
SWITCH-BASE
135741-01-CHT
SWITCH-BEZEL
135742-01-CHT
SCREW
G11-08-08U (2)

DETAIL DA

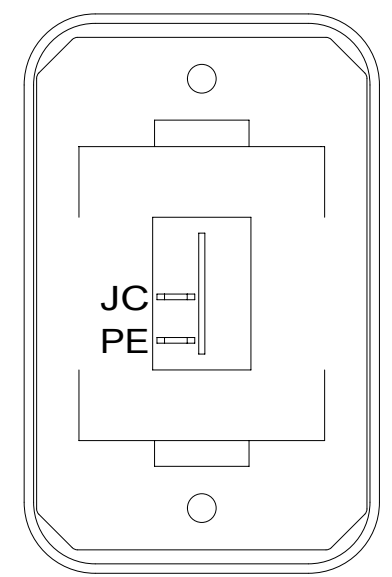

SWITCH-ROCKER
135740-01-CHT
SWITCH-BASE
135741-01-CHT
SWITCH-BEZEL
135742-01-CHT
SCREW
G11-08-08U (2)

DETAIL DB

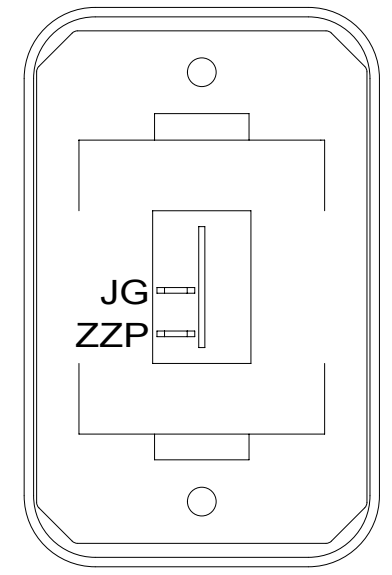

SWITCH-ROCKER
135740-01-CHT
SWITCH-BASE
135741-01-CHT
SWITCH-BEZEL
135742-01-CHT
SCREW
G11-08-08U (2)

DETAIL DC

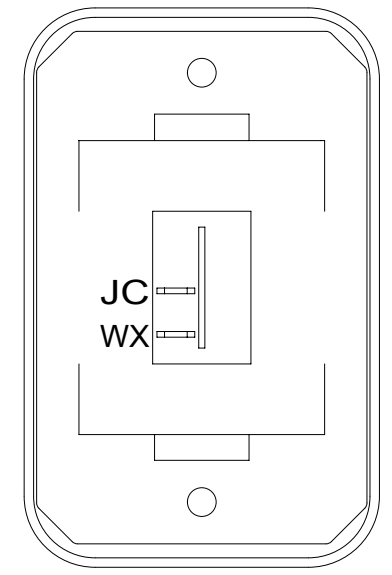

SWITCH-ROCKER
135740-01-CHT
SWITCH-BASE
135741-01-CHT
SWITCH-BEZEL
135742-01-CHT
SCREW
G11-08-08U (2)

DETAIL DD

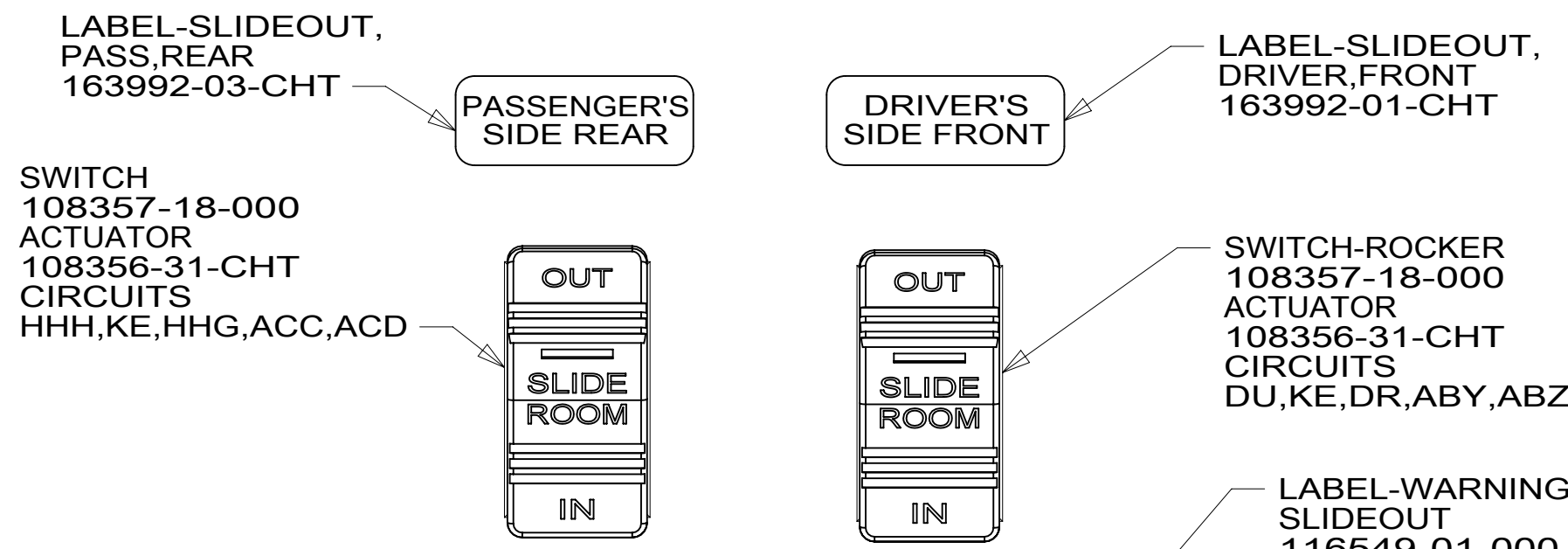

SWITCH
108357-18-000
ACTUATOR
108356-31-CHT
CIRCUITS
HHH,KE,HHG,ACC,ACD

LABEL-SLIDEOUT,
PASS,REAR
163992-03-CHT

DRIVER'S
SIDE FRONT

LABEL-SLIDEOUT,
DRIVER,FRONT
163992-01-CHT

SWITCH-ROCKER
108357-18-000
ACTUATOR
108356-31-CHT
CIRCUITS
DU,KE,DR,ABY,ABZ

LABEL-WARNING,
SLIDEOUT
116549-01-000

WARNING CRUSH HAZARD. Keep people and objects clear of the inside and the outside of the slideout room when operating. Failure to comply could result in death or serious injury.

DETAIL DE

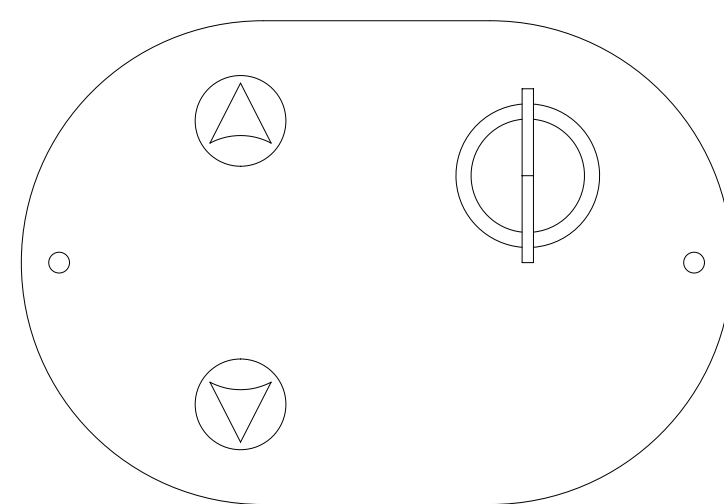

SWITCH-CONTROL,LOFTBED,TOUCH
189056-01-000
WIRE ASM-LOFT BED SWITCH
000122806 / 323456-01-000
SCREW
000G11-02-08U (2)

DETAIL DF 45B

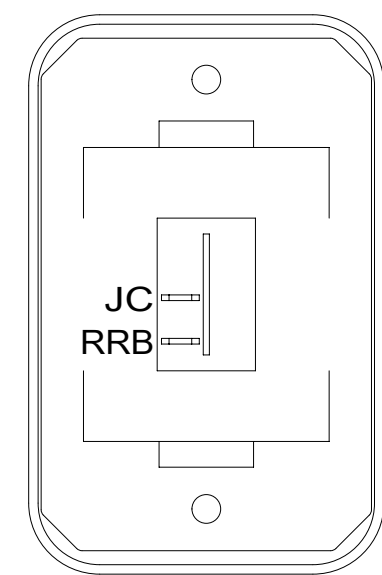

SWITCH-ROCKER
135740-01-CHT
SWITCH-BASE
135741-01-CHT
SWITCH-BEZEL
135742-01-CHT
SCREW
G11-08-08U (2)

DETAIL DG

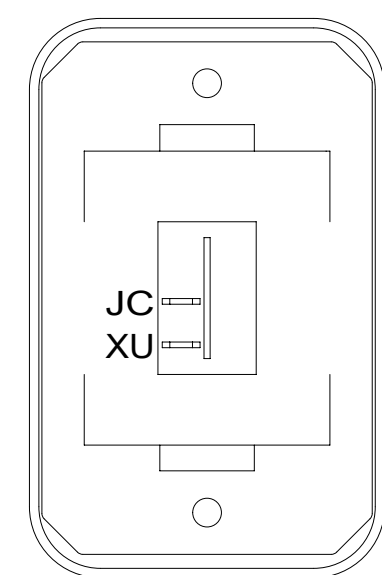

SWITCH-ROCKER
135740-01-CHT
SWITCH-BASE
135741-01-CHT
SWITCH-BEZEL
135742-01-CHT
SCREW
G11-08-08U (2)

DETAIL DH

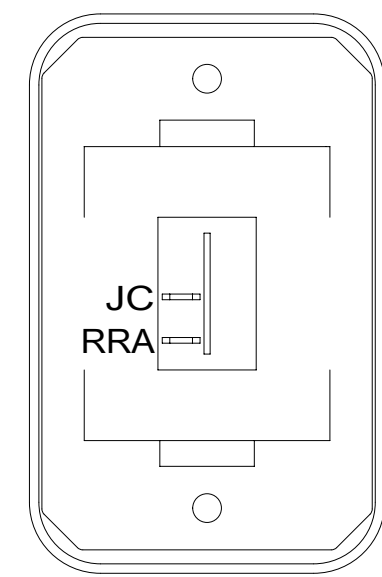

SWITCH-ROCKER
135740-01-CHT
SWITCH-BASE
135741-01-CHT
SWITCH-BEZEL
135742-01-CHT
SCREW
G11-08-08U (2)

DETAIL DJ

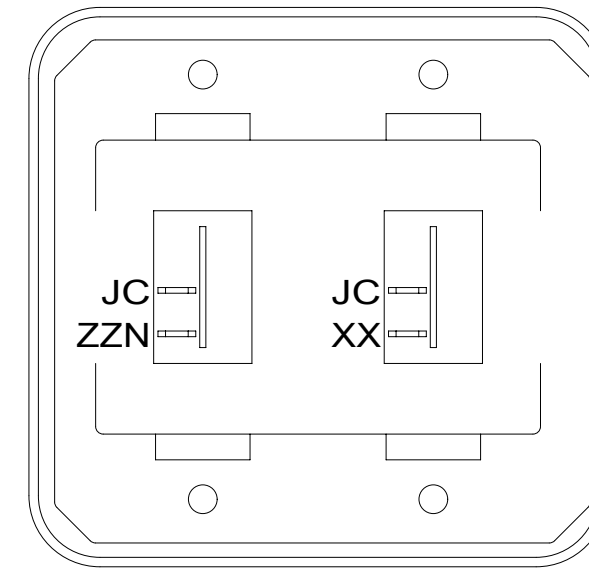

SWITCH-ROCKER
135740-01-CHT (2)
SWITCH-BASE
135741-02-CHT
SWITCH-BEZEL
135742-02-CHT
SCREW
G11-08-08U (4)

DETAIL DK

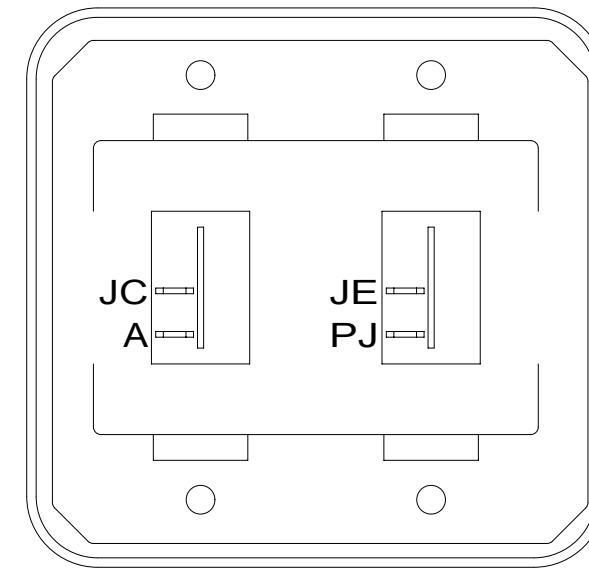

SWITCH-ROCKER
135740-01-CHT (2)
SWITCH-BASE
135741-02-CHT
SWITCH-BEZEL
135742-02-CHT
SCREW
G11-08-08U (4)

DETAIL DL

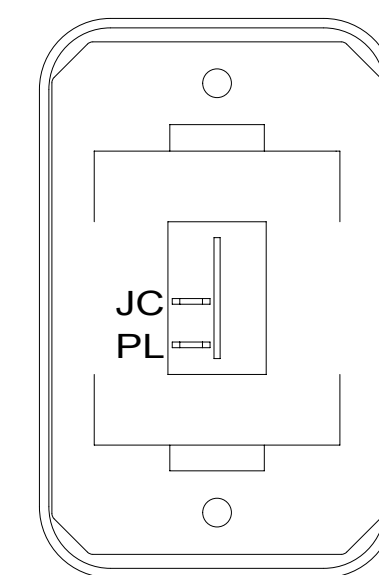

SWITCH-ROCKER
135740-01-CHT
SWITCH-BASE
135741-01-CHT
SWITCH-BEZEL
135742-01-CHT
SCREW
G11-08-08U (2)

DETAIL DM

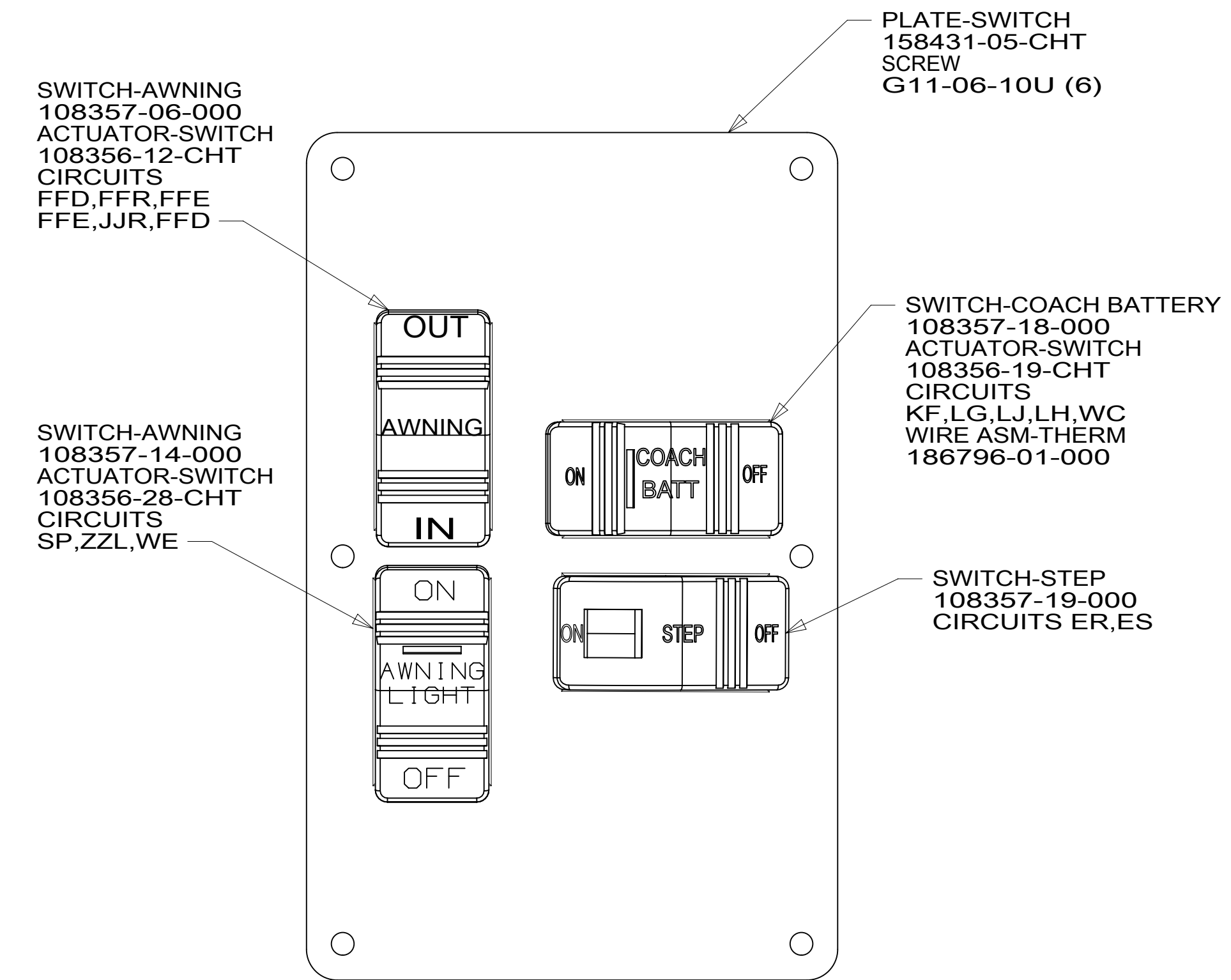

SWITCH-AWNING
108357-06-000
ACTUATOR-SWITCH
108356-12-CHT
CIRCUITS
FFD,FFR,FFE
FFE,JJR,FFD

SWITCH-AWNING
108357-14-000
ACTUATOR-SWITCH
108356-28-CHT
CIRCUITS
SP,ZZL,WE

PLATE-SWITCH
158431-05-CHT
SCREW
G11-06-10U (6)

SWITCH-COACH BATTERY
108357-18-000
ACTUATOR-SWITCH
108356-19-CHT
CIRCUITS
KF,LG,LJ,LH,WC
WIRE ASM-THERM
186796-01-000

SWITCH-STEP
108357-19-000
CIRCUITS ER,ES

DETAIL DN 1

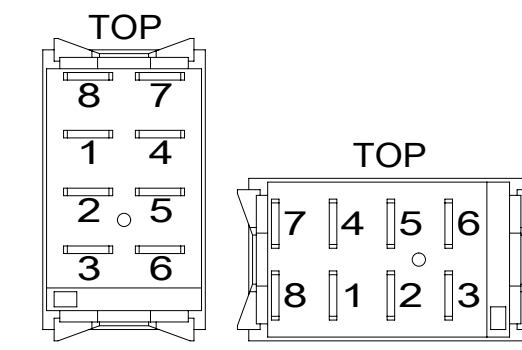

DETAIL DP

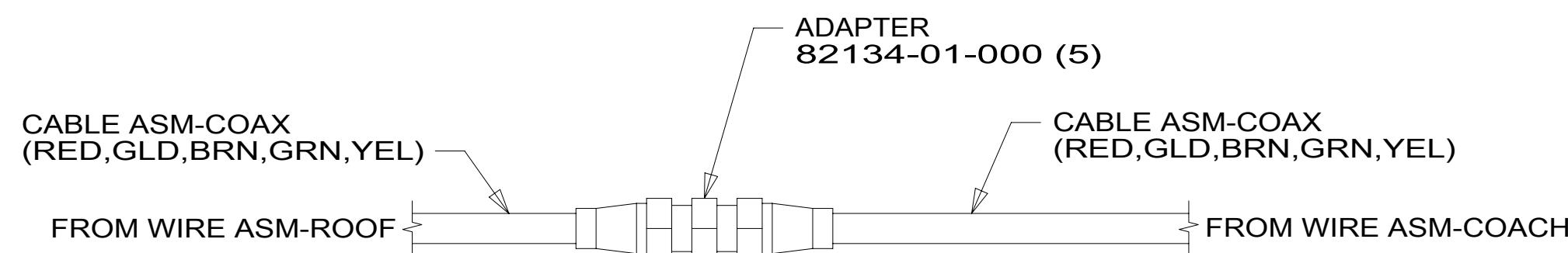

DETAIL DR

1 FOR SWITCH ORIENTATION SEE DETAIL DP.
NOTES:

FOR ELECTRICAL
TORQUE
SPECIFICATIONS
SEE DWG NO.
128783-01-000

X-X
FOR ELECTRICAL
CALLOUTS
SEE DWG NO.
121339-01-000

- 45B LOFT BED
- 265 CODES/STANDARDS-CSA/CMVSS
- 1B1 CODES/STANDARDS USA

DESCRIPTION: WIRING INSTL-BODY, 12V	
SHEET: 4 OF 7	ITEM/PART NO: 000131232 / 32567301000
REV	

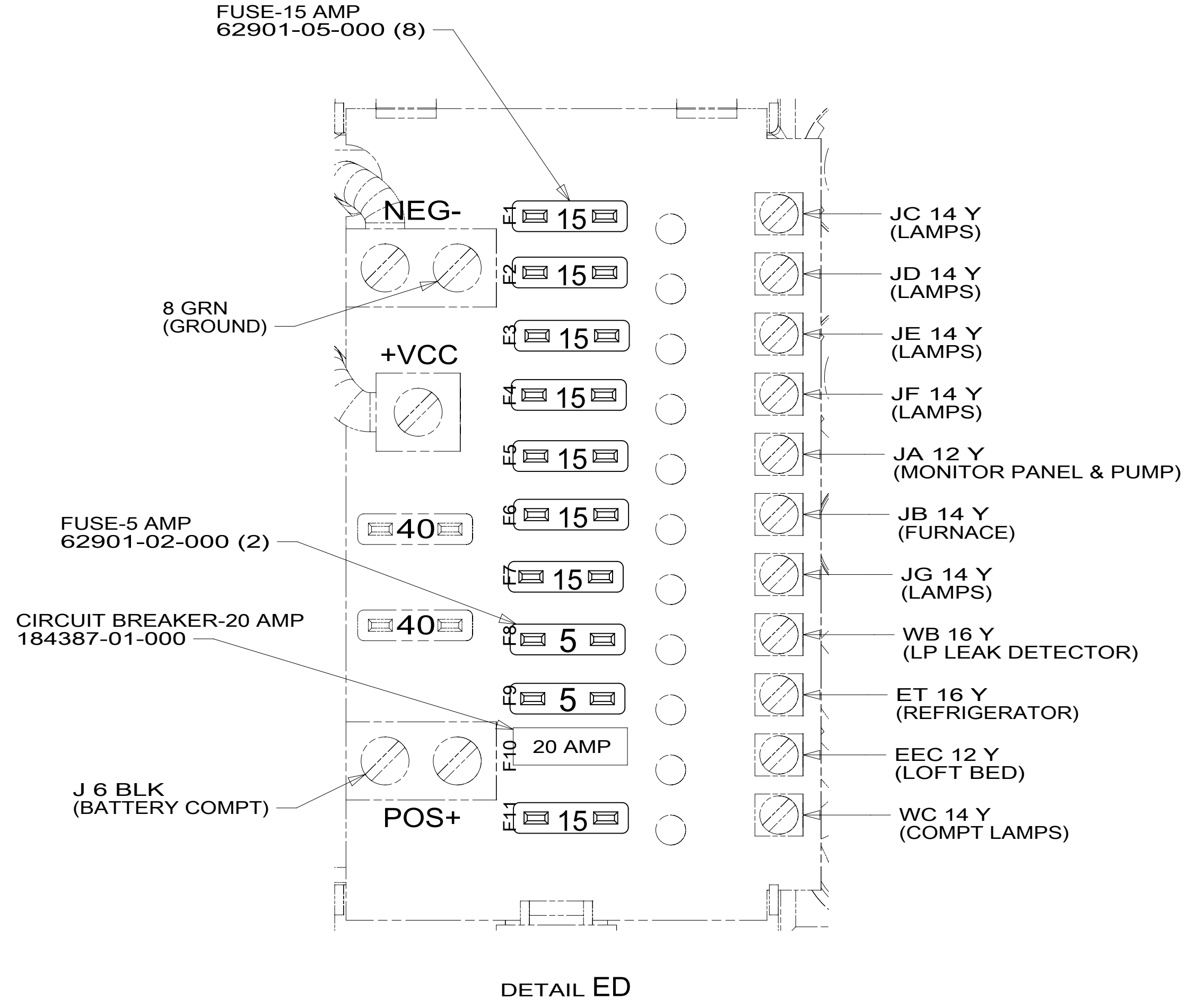
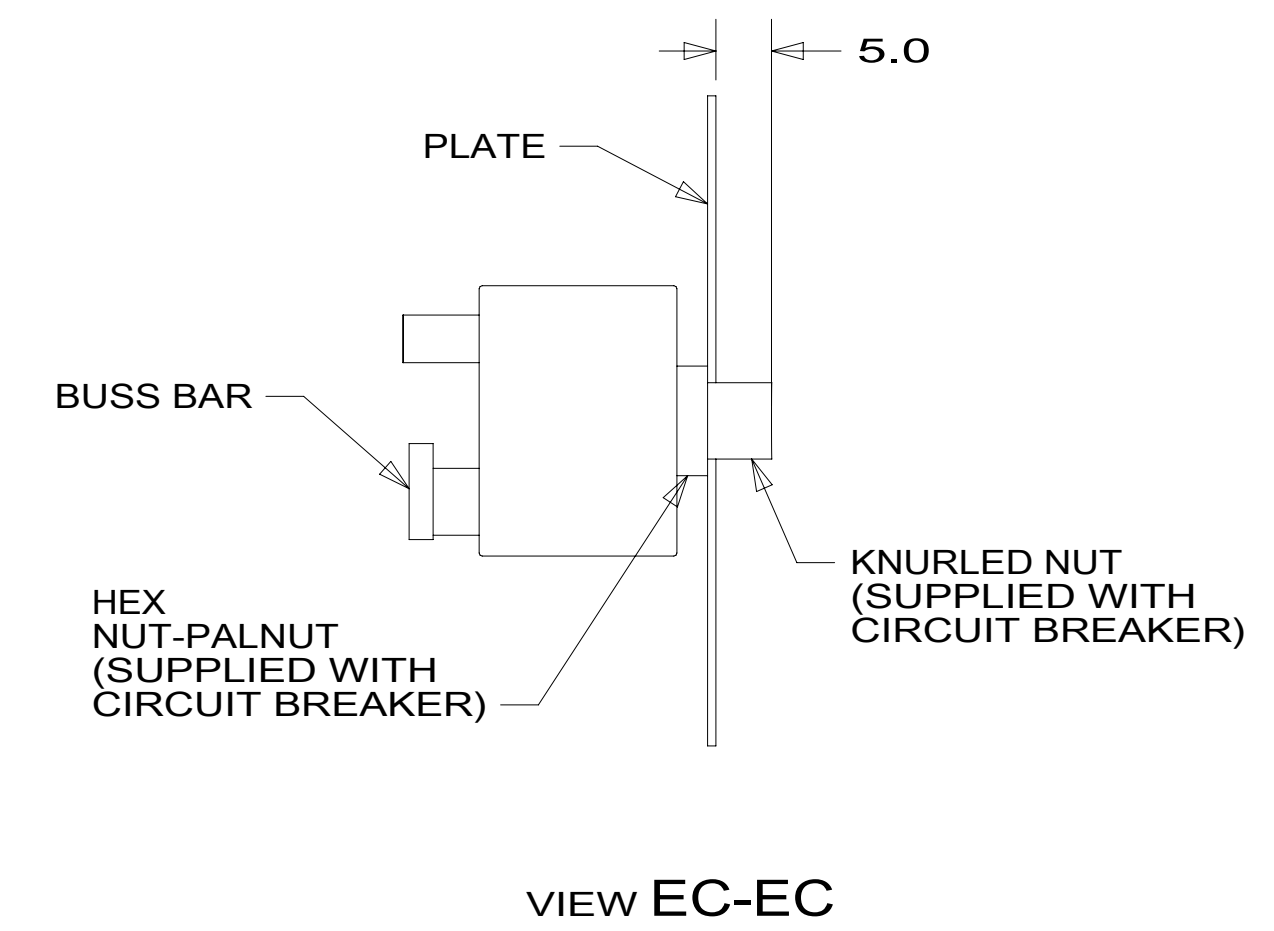
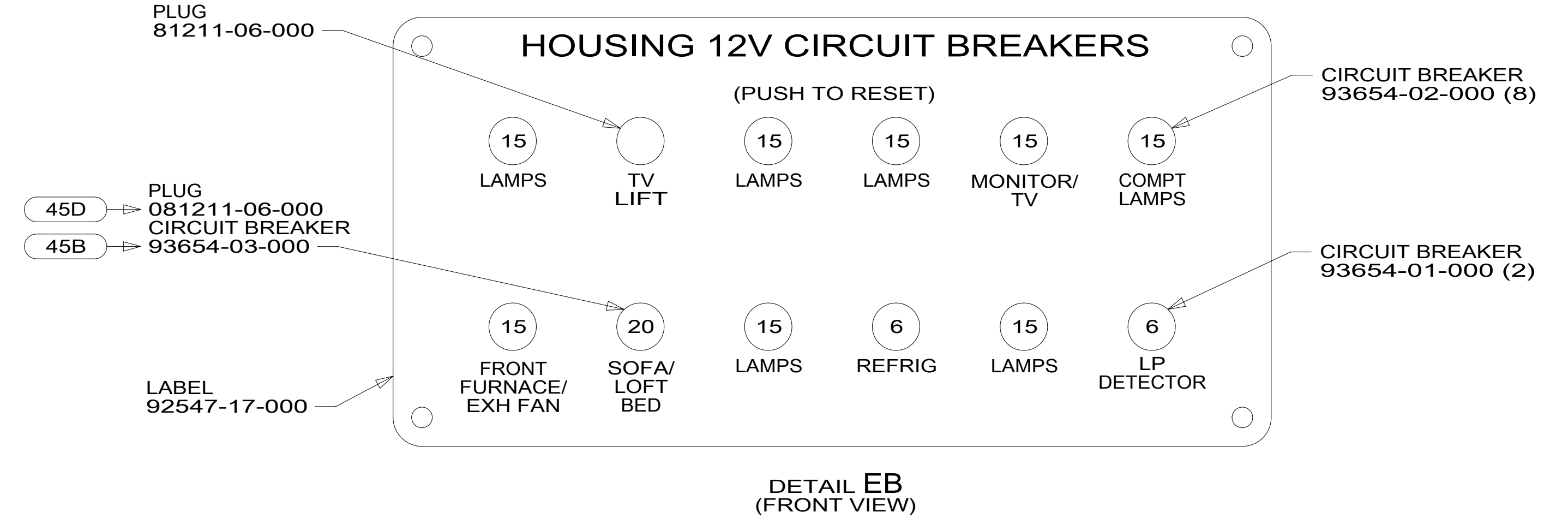
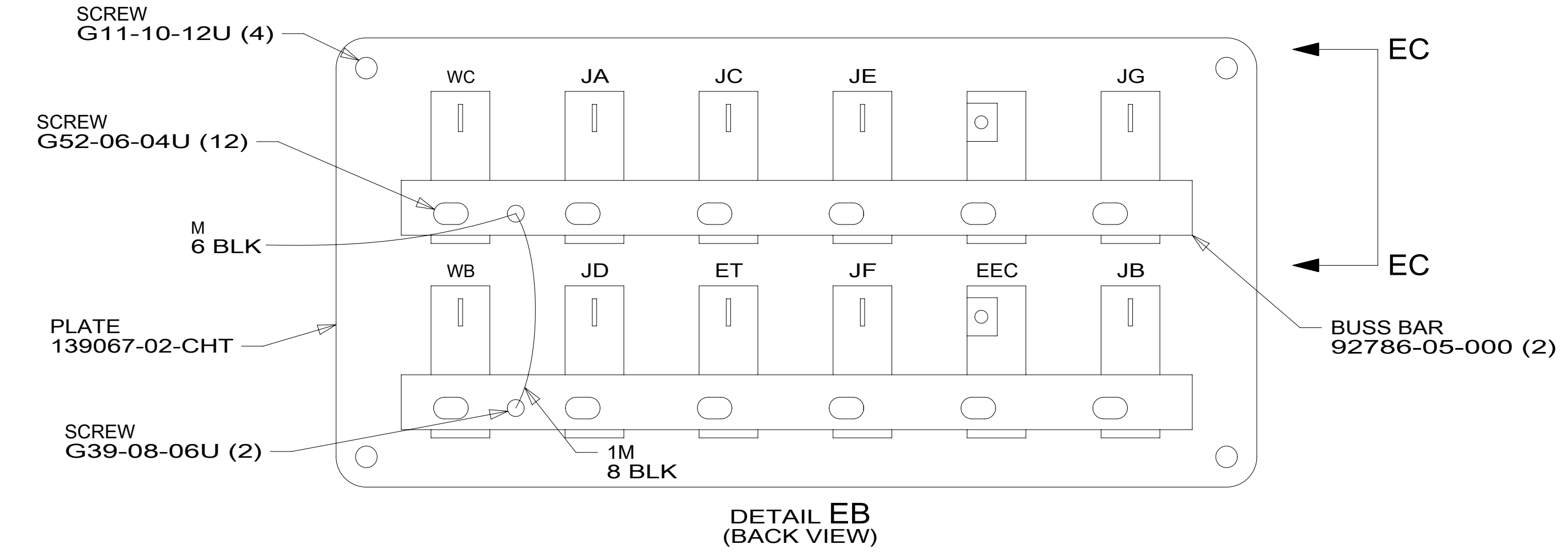
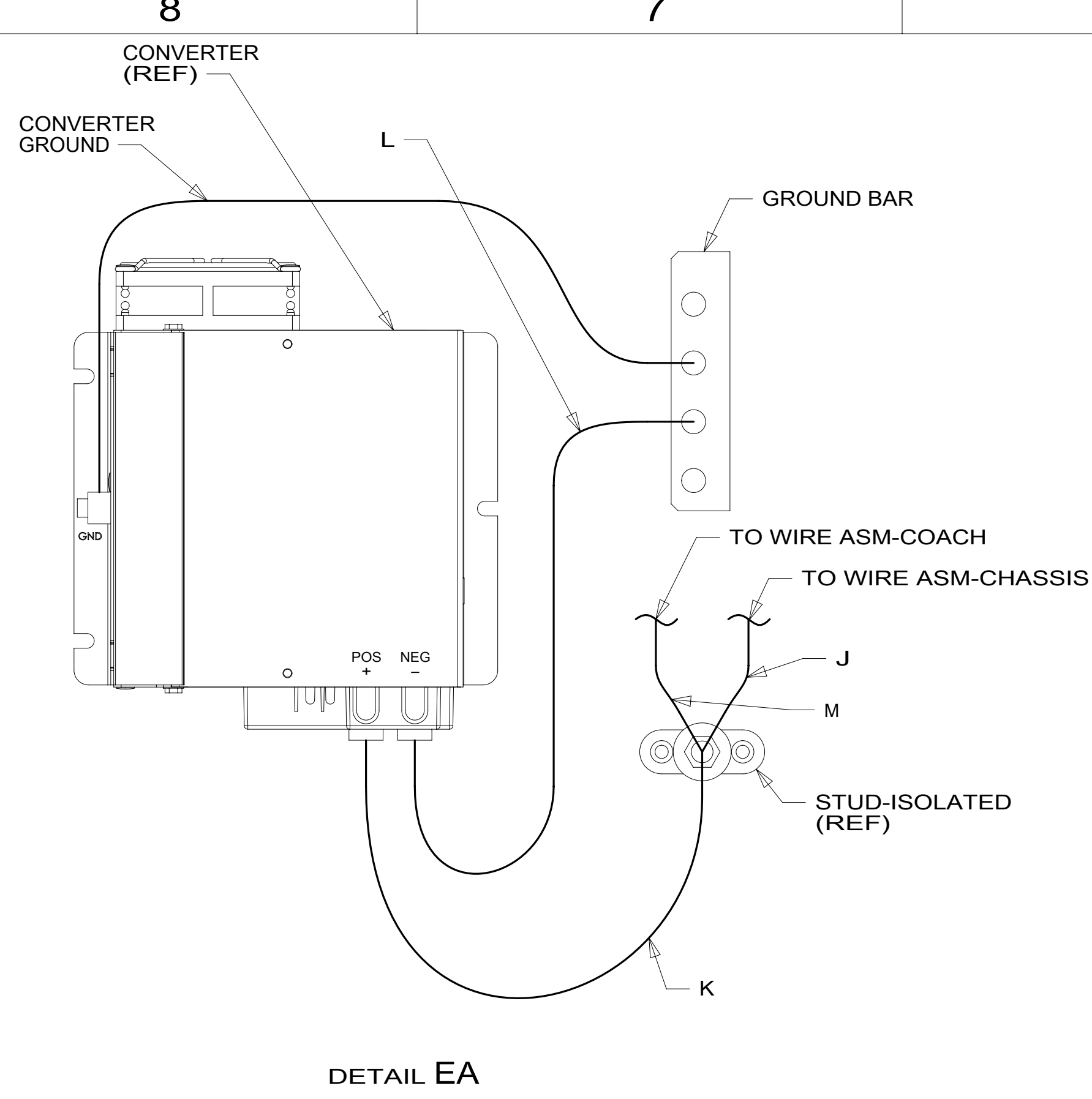

- 45B LOFT BED
- 45D LOFT BED - WITHOUT
- 265 CODES/STANDARDS-CSA/CMVSS
- 1B1 CODES/STANDARDS USA

FOR ELECTRICAL TORQUE SPECIFICATIONS SEE DWG NO. 128783-01-000

X-X

FOR ELECTRICAL CALLOUTS SEE DWG NO. 121339-01-000

DESCRIPTION: WIRING INSTL-BODY, 12V		
SHEET: 5 OF 7	ITEM/PART NO: 000131232 / 32567301000	REV

8 7 6 5 4 3 2 1



D
C
B
A

D
C
B
A

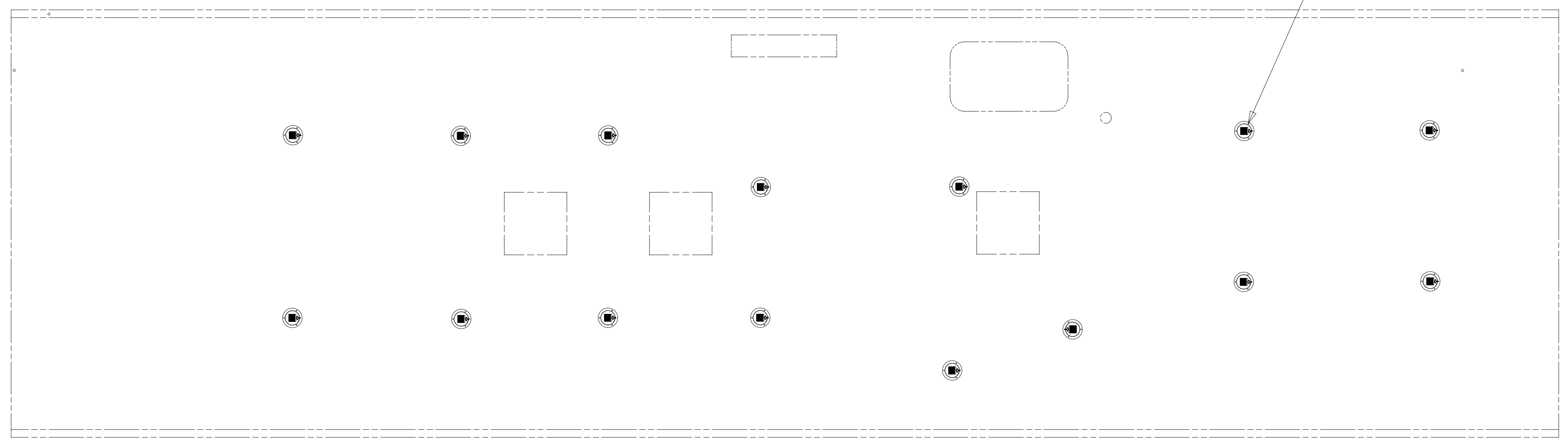

8 7 6 5 4 3 2 1 12-Jan-2018

265 CODES/STANDARDS-CSA/CMVSS
 1B1 CODES/STANDARDS USA

FOR ELECTRICAL TORQUE SPECIFICATIONS SEE DWG NO. 128783-01-000

FOR ELECTRICAL CALLOUTS SEE DWG NO. 121339-01-000

1B1	265
DESCRIPTION: WIRING INSTL-BODY, 12V	
SHEET: 6 OF 7	ITEM/PART NO: 000131232 / 32567301000
REV	

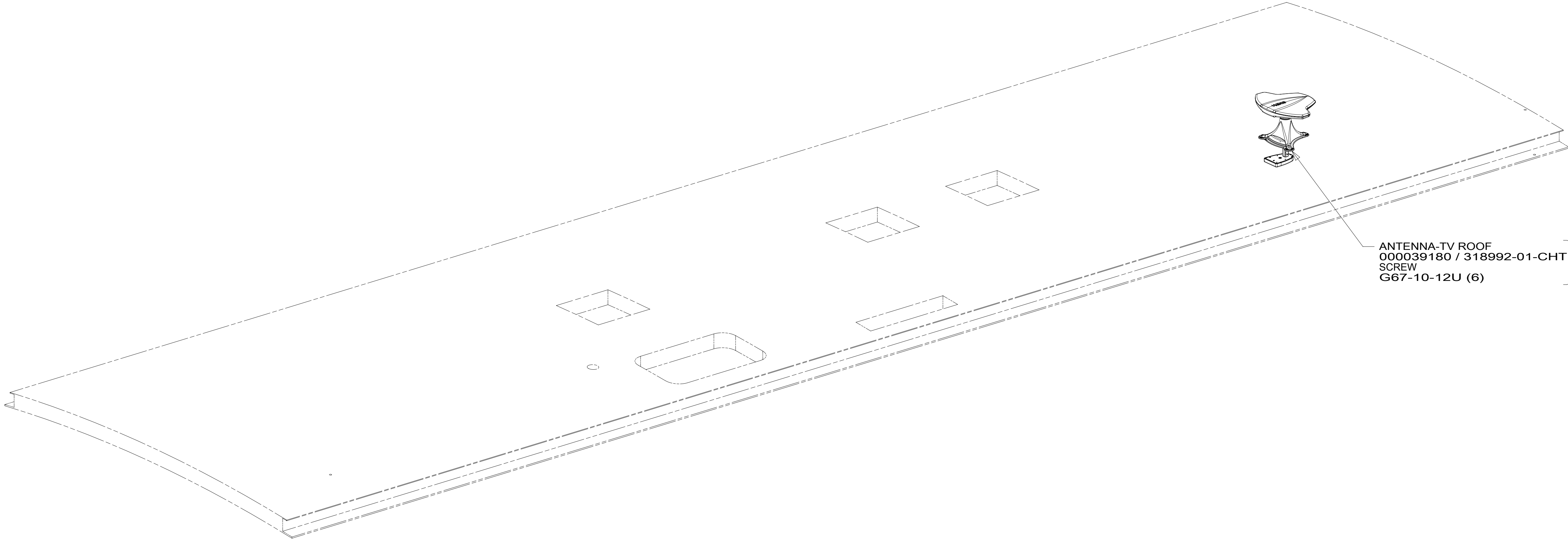

ANTENNA-TV ROOF
 000039180 / 318992-01-CHT
 SCREW
 G67-10-12U (6)

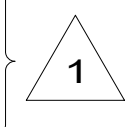

1 SEE ANTENNA INSTALLATION MANUAL FOR CORRECT
 INSTALLATION PROCEDURE.

NOTES:

FOR ELECTRICAL
 TORQUE
 SPECIFICATIONS
 SEE DWG NO.
 128783-01-000

FOR
 ELECTRICAL
 CALLOUTS
 SEE DWG NO.
 121339-01-000

- 265 CODES/STANDARDS-CSA/CMVSS
- 1B1 CODES/STANDARDS USA

1B1 265	
DESCRIPTION: WIRING INSTL-BODY, 12V	
SHEET: 7 OF 7	ITEM/PART NO.: 000131232 / 32567301000
REV	