

DETAIL AB

DETAIL AC

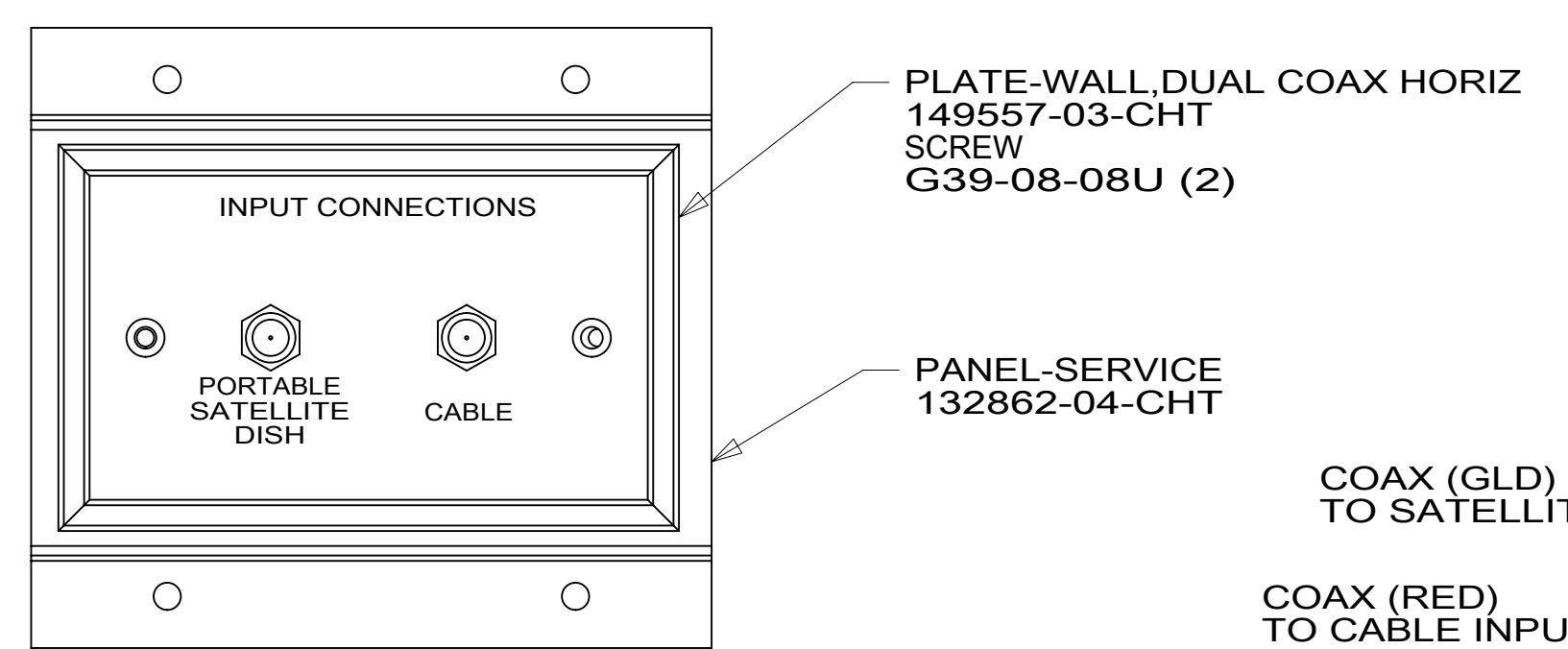

VIEW AA

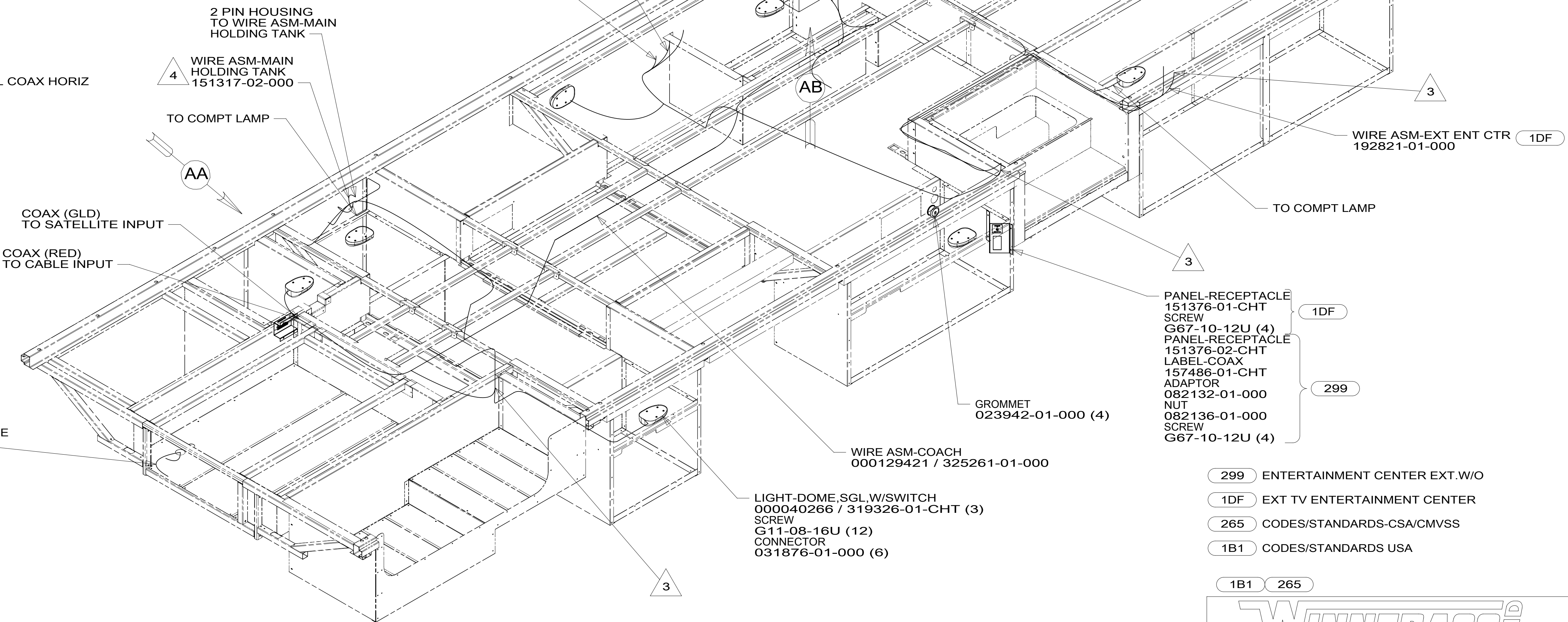

- 5 WIRES ARE PART OF WIRE ASM-CHASSIS.
- 4 PLACE CROSS LOCATOR ON SENSORS OVER DIMPLES ON TANK.
- 3 WIRE PASSES THROUGH FLOOR IN THIS AREA.
2. ROUTE TANK SENSOR WIRES SO THEY DO NOT PASS OVER SENSORS. USE WIRE TIE MOUNT 155366-01-000 AND WIRE TIE 8343-01-000 AS NEEDED. TANK SURFACE MUST BE CLEANED USING ISOPROPYL ALCOHOL AND PRIMED WITH PRIMER 94.
1. ALL WIRES TO BE SECURED WITH CLAMP 10495 OR 10497 OR WIRE TIE 8343 OR 108046 EVERY 600MM, USE SCREW G67-XX-XXX OR G56-XX-XXX AS APPROPRIATE FOR INSTALLATION.

- 299 ENTERTAINMENT CENTER EXT.W/O
- 1DF EXT TV ENTERTAINMENT CENTER
- 265 CODES/STANDARDS-CSA/CMVSS
- 1B1 CODES/STANDARDS USA

**WINNEBAGO**  
COPYRIGHT 2016 WINNEBAGO INDUSTRIES, INC.

DSNR:	ALL DIMENSIONS ARE IN MILLIMETERS	
DIFFR:	MATERIAL:	
UNSPECIFIED TOLERANCES:		
WHOLE DIM (X) :	3	
ONE-PLACE (X.X) :	1.5	
TWO-PLACE (X.XX) :	0.50	
ANGLE :	1°	
REFER TO ES0018 FOR FASTENER TIGHTENING GUIDELINES	WEIGHT: (LBS)	FIRST USED:
		18 E31BE
DESCRIPTION: <b>WIRING INSTL-BODY, 12V</b>		
SHEET: 1 OF 6	ITEM/PART NO: 000129354 / 32522401000	REV:

FOR ELECTRICAL TORQUE SPECIFICATIONS SEE DWG NO. 128783-01-000

FOR ELECTRICAL CALLOUTS SEE DWG NO. 121339-01-000

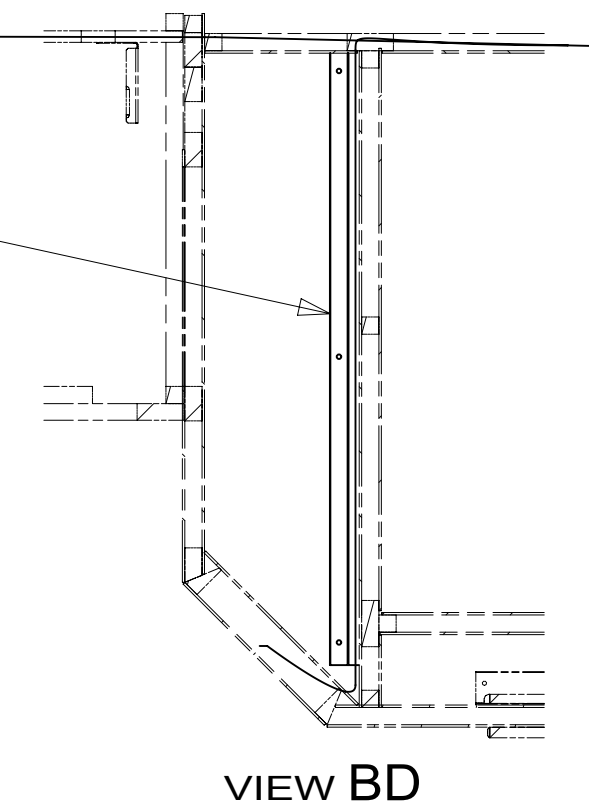
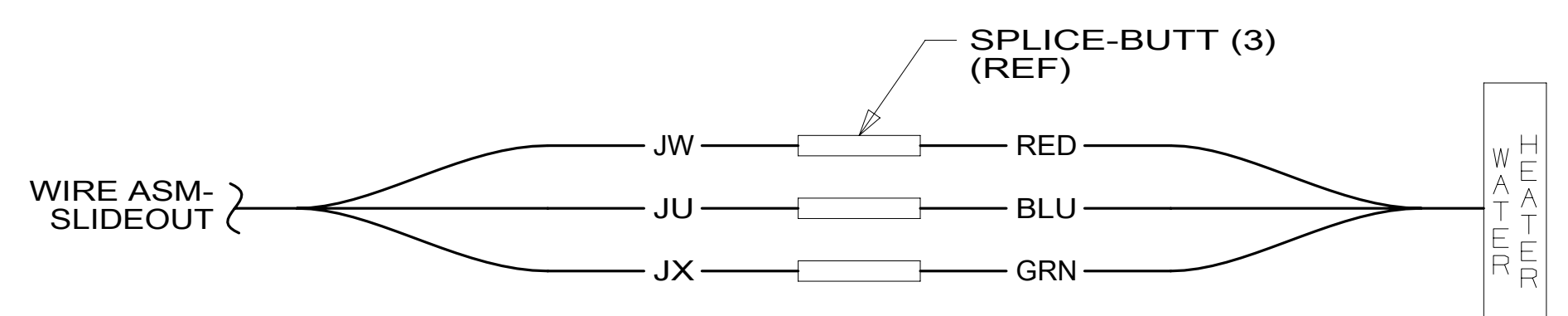
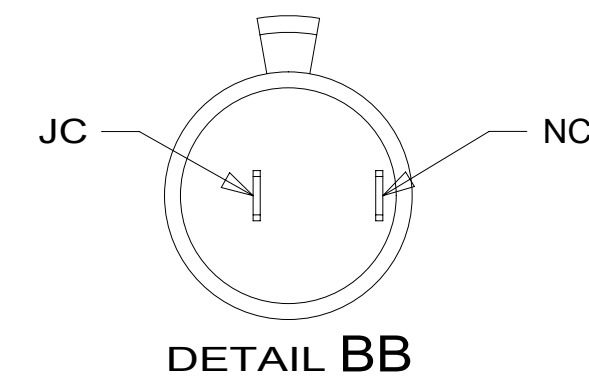
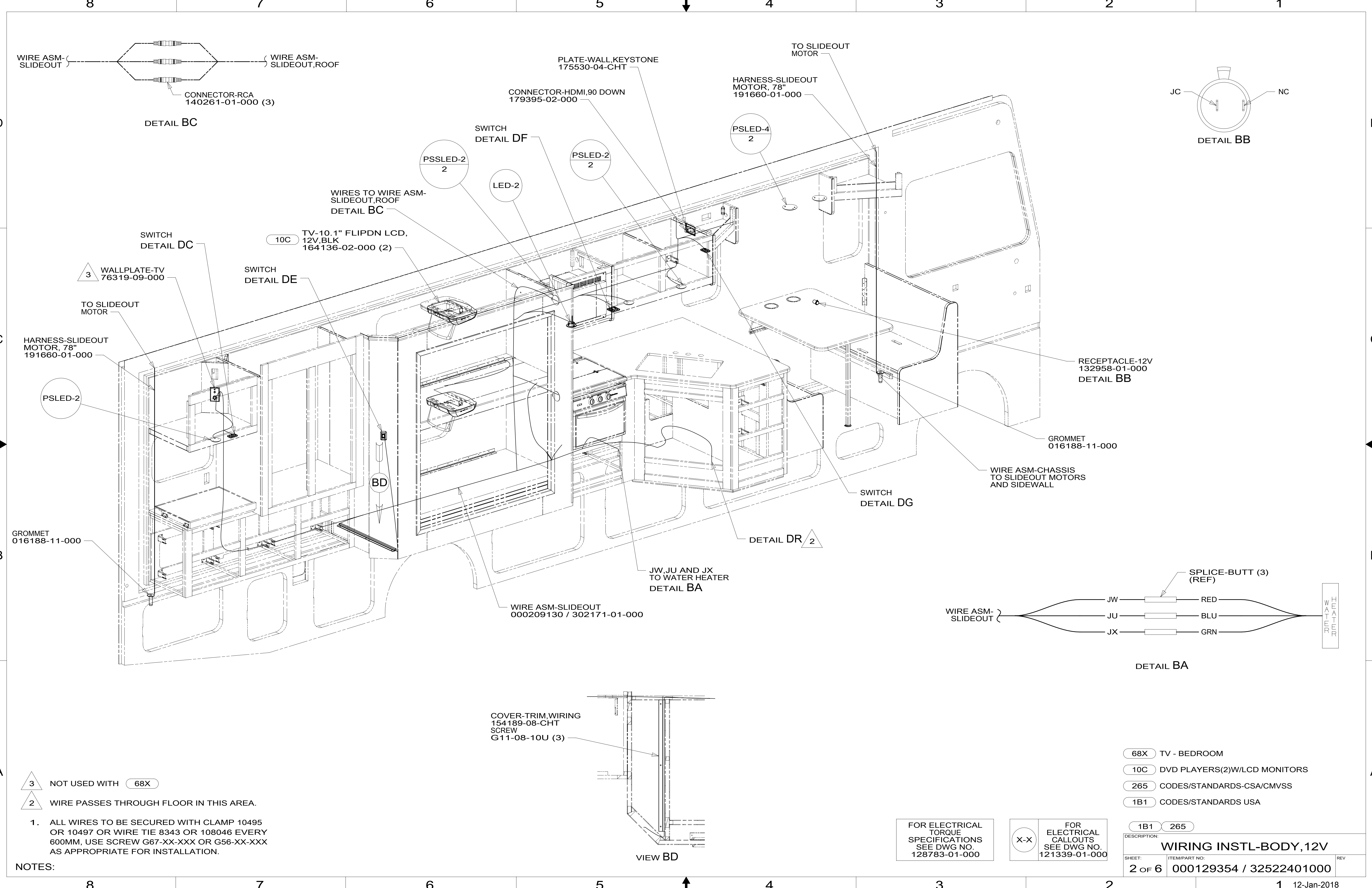

- 3 NOT USED WITH 68X
- 2 WIRE PASSES THROUGH FLOOR IN THIS AREA.

1. ALL WIRES TO BE SECURED WITH CLAMP 10495 OR 10497 OR WIRE TIE 8343 OR 108046 EVERY 600MM, USE SCREW G67-XX-XXX OR G56-XX-XXX AS APPROPRIATE FOR INSTALLATION.

NOTES:

FOR ELECTRICAL TORQUE SPECIFICATIONS SEE DWG NO. 128783-01-000

FOR ELECTRICAL CALLOUTS SEE DWG NO. 121339-01-000

- 68X TV - BEDROOM
- 10C DVD PLAYERS(2)W/LCD MONITORS
- 265 CODES/STANDARDS-CSA/CMVSS
- 1B1 CODES/STANDARDS USA

DESCRIPTION:	1B1 265	
<b>WIRING INSTL-BODY, 12V</b>		
SHEET:	ITEM/PART NO:	REV
2 OF 6	000129354 / 32522401000	

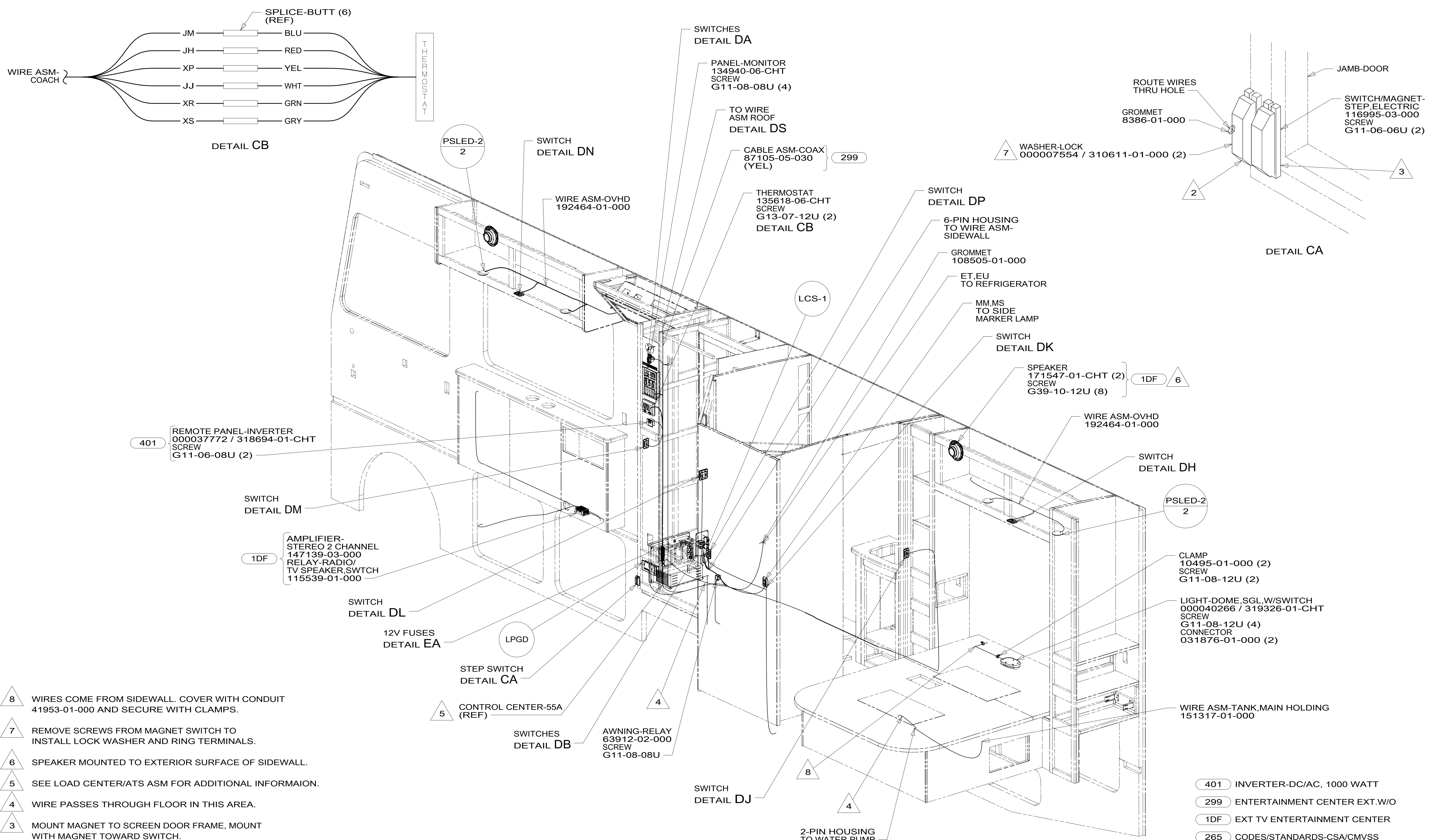

- 8 WIRES COME FROM SIDEWALL. COVER WITH CONDUIT 41953-01-000 AND SECURE WITH CLAMPS.
- 7 REMOVE SCREWS FROM MAGNET SWITCH TO INSTALL LOCK WASHER AND RING TERMINALS.
- 6 SPEAKER MOUNTED TO EXTERIOR SURFACE OF SIDEWALL.
- 5 SEE LOAD CENTER/ATS ASM FOR ADDITIONAL INFORMATION.
- 4 WIRE PASSES THROUGH FLOOR IN THIS AREA.
- 3 MOUNT MAGNET TO SCREEN DOOR FRAME, MOUNT WITH MAGNET TOWARD SWITCH.
- 2 MOUNT SWITCH TO DOOR JAMB WITH TAPE 076322-21-000.

1. ALL WIRES TO BE SECURED WITH CLAMP 10495 OR 10497 OR WIRE TIE 8343 OR 108046 EVERY 600MM, USE SCREW G67-XX-XXX OR G56-XX-XXX AS APPROPRIATE FOR INSTALLATION.

NOTES:

FOR ELECTRICAL TORQUE SPECIFICATIONS SEE DWG NO. 128783-01-000

FOR ELECTRICAL CALLOUTS SEE DWG NO. 121339-01-000

- 401 INVERTER-DC/AC, 1000 WATT
- 299 ENTERTAINMENT CENTER EXT. W/O
- 1DF EXT TV ENTERTAINMENT CENTER
- 265 CODES/STANDARDS-CSA/CMVSS
- 1B1 CODES/STANDARDS USA

DESCRIPTION:		1B1 265	
<b>WIRING INSTL-BODY, 12V</b>			
SHEET:	ITEM/PART NO.:	REV:	
3 OF 6	000129354 / 32522401000		

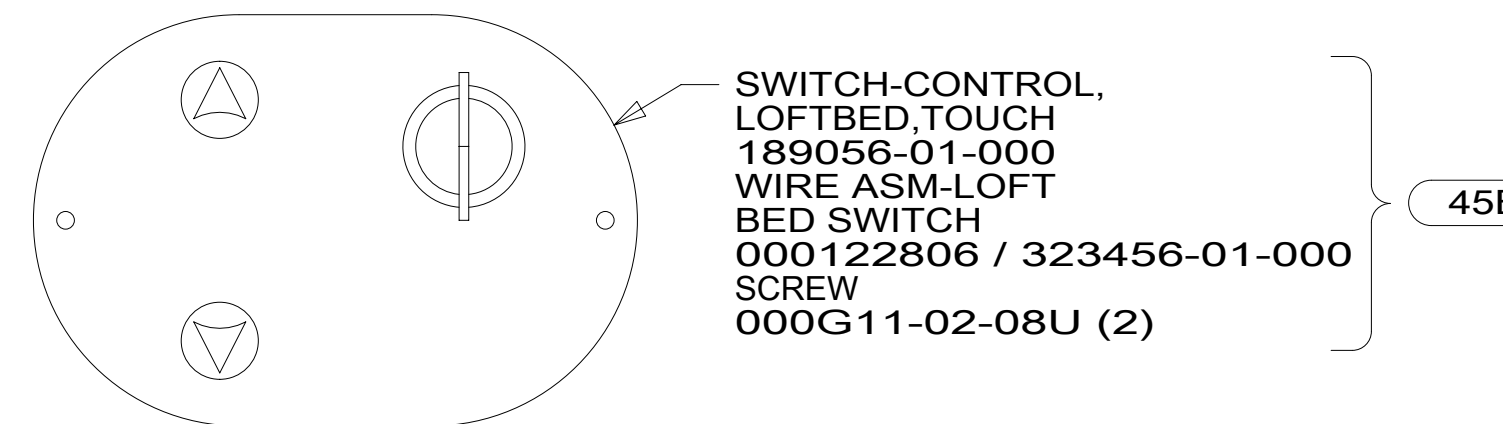

SWITCH-CONTROL, LOFTBED, TOUCH  
189056-01-000  
WIRE ASM-LOFT  
BED SWITCH  
000122806 / 323456-01-000  
SCREW  
000G11-02-08U (2)

45B

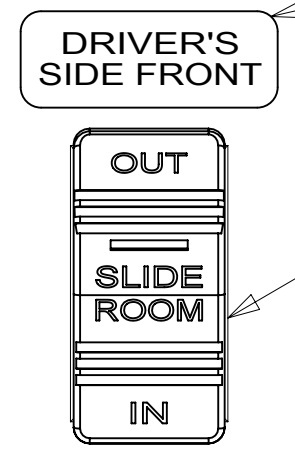

LABEL-SLIDEOUT, DRIVER, FRONT  
163992-01-CHT

SWITCH  
108357-18-000  
ACTUATOR  
108356-31-CHT  
CIRCUITS  
DR, KE, DU  
ABY, ABZ

LABEL-WARNING, SLIDEOUT  
116549-01-000

**WARNING** CRUSH HAZARD. Keep people and objects clear of the inside and the outside of the slideout room when operating. Failure to comply could result in death or serious injury.

DETAIL DA

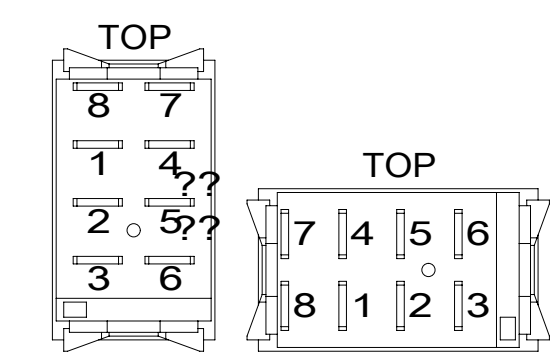

DETAIL DD

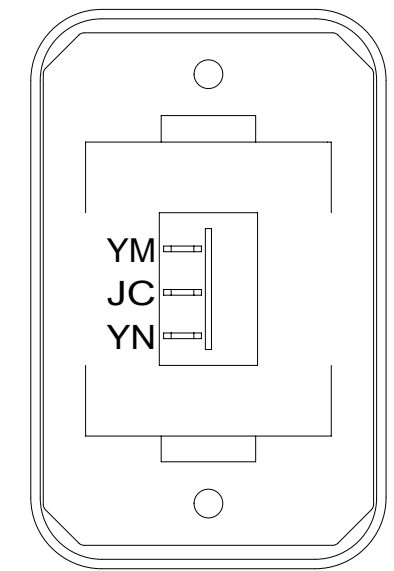

DETAIL DJ

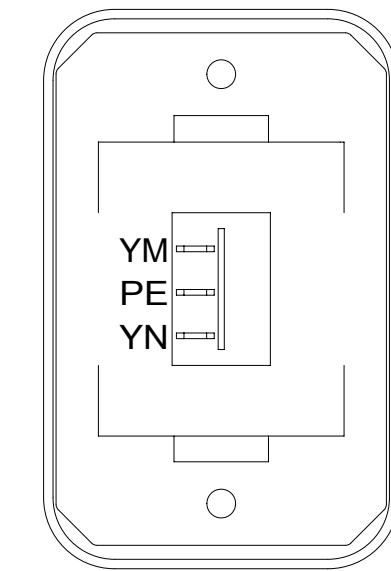

DETAIL DP

SWITCH-ROCKER  
135740-02-CHT  
SWITCH-BASE  
135741-01-CHT  
SWITCH-BEZEL  
135742-01-CHT  
SCREW  
G11-08-08U (2)

SWITCH-ROCKER  
135740-02-CHT  
SWITCH-BASE  
135741-01-CHT  
SWITCH-BEZEL  
135742-01-CHT  
SCREW  
G11-08-08U (2)

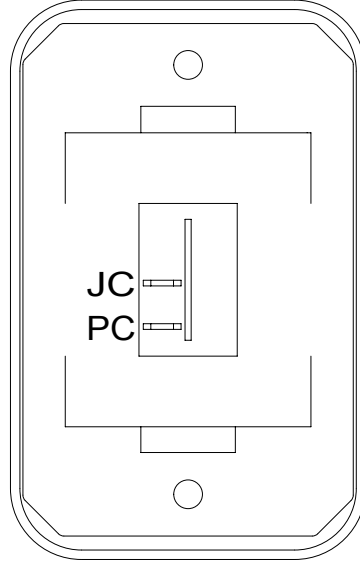

DETAIL DE

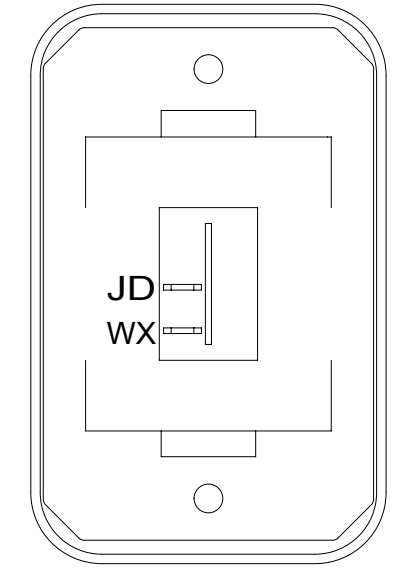

DETAIL DK

SWITCH-ROCKER  
135740-01-CHT  
SWITCH-BASE  
135741-01-CHT  
SWITCH-BEZEL  
135742-01-CHT  
SCREW  
G11-08-08U (2)

SWITCH-ROCKER  
135740-01-CHT  
SWITCH-BASE  
135741-01-CHT  
SWITCH-BEZEL  
135742-01-CHT  
SCREW  
G11-08-08U (2)

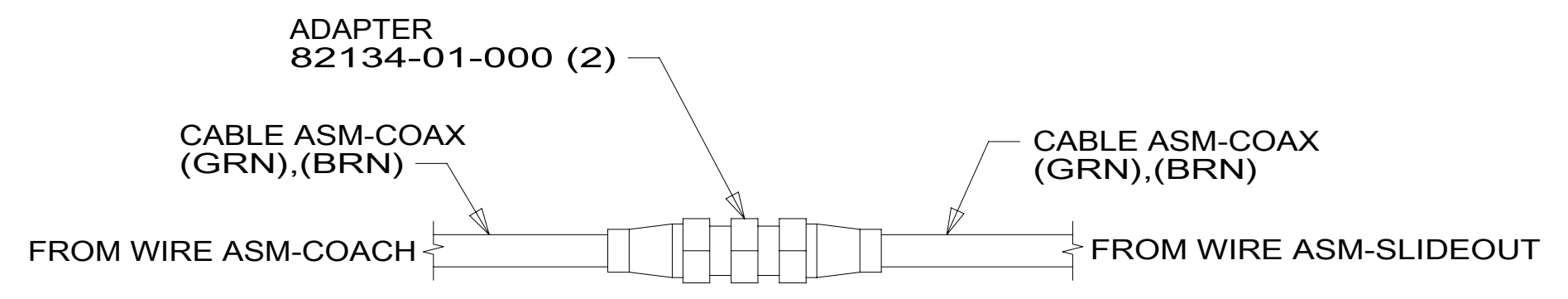

DETAIL DR

ADAPTER  
82134-01-000 (2)

CABLE ASM-COAX (GRN),(BRN)

CABLE ASM-COAX (GRN),(BRN)

FROM WIRE ASM-COACH

FROM WIRE ASM-SLIDEOUT

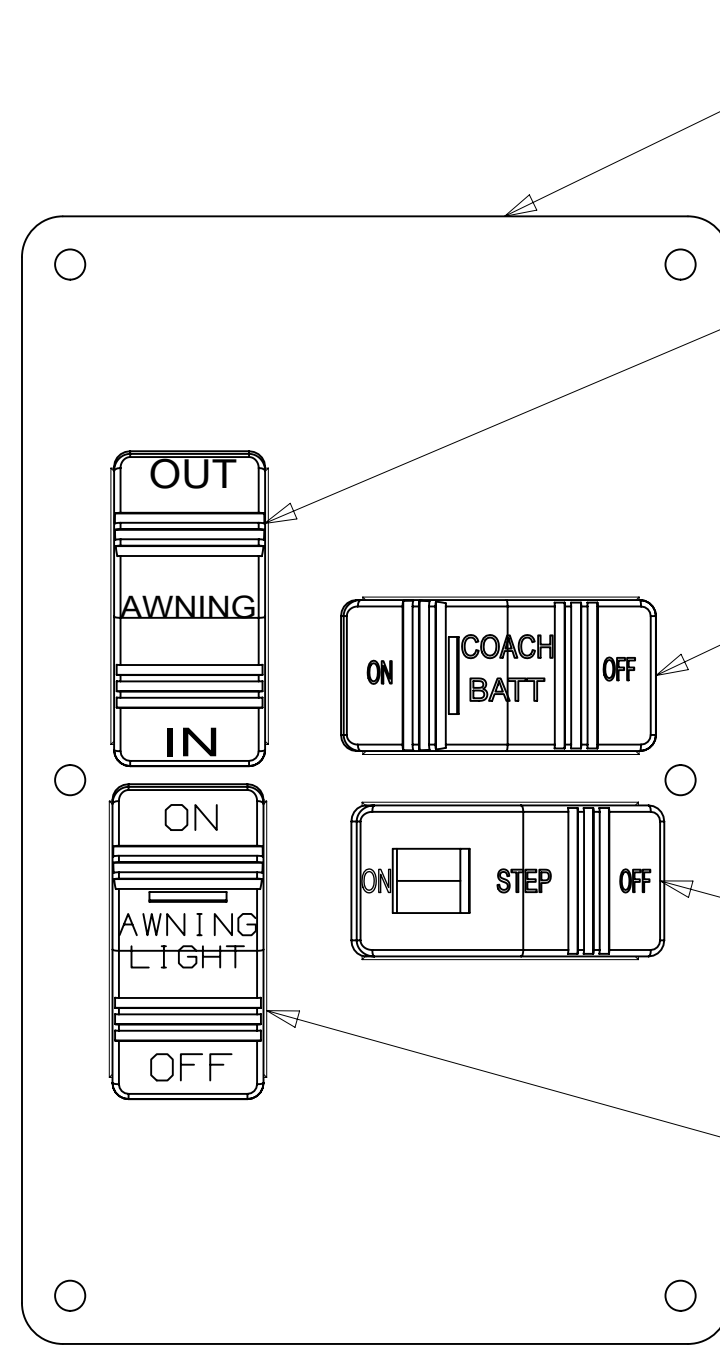

DETAIL DB 1

PLATE-SWITCH  
158431-05-CHT  
SCREW  
G11-06-10U (4)

SWITCH-AWNING  
108357-06-000  
ACTUATOR-SWITCH  
108356-12-CHT  
CIRCUITS  
FFD,FFR,FFE  
FFE,JJR,FFD

SWITCH-COACH BATTERY  
108357-18-000  
ACTUATOR-SWITCH  
108356-19-CHT  
CIRCUITS  
KF,LG,LJ,LH,WC  
WIRE ASM-THERM  
186796-01-000

SWITCH-STEP  
108357-19-000  
CIRCUITS ER,ES

SWITCH-AWNING  
108357-14-000  
ACTUATOR-SWITCH  
108356-28-CHT  
CIRCUITS  
SP,ZZL,WE

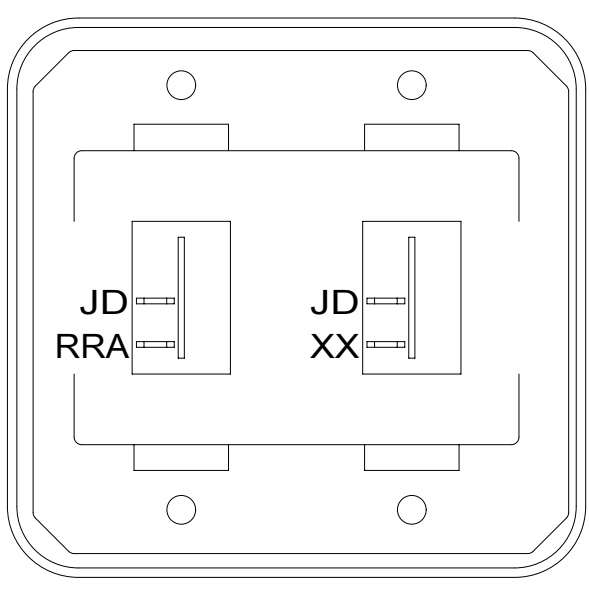

DETAIL DF

SWITCH-ROCKER  
135740-01-CHT (2)  
SWITCH-BASE  
135741-02-CHT  
SWITCH-BEZEL  
135742-02-CHT  
SCREW  
G11-08-08U (4)

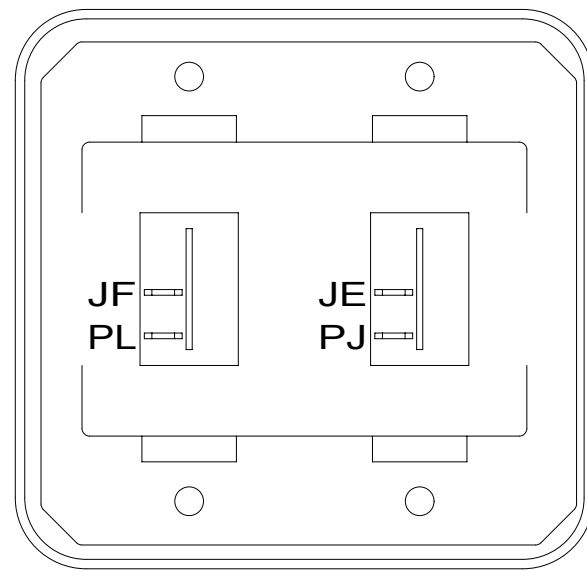

DETAIL DL

SWITCH-ROCKER  
135740-01-CHT (2)  
SWITCH-BASE  
135741-02-CHT  
SWITCH-BEZEL  
135742-02-CHT  
SCREW  
G11-08-08U (4)

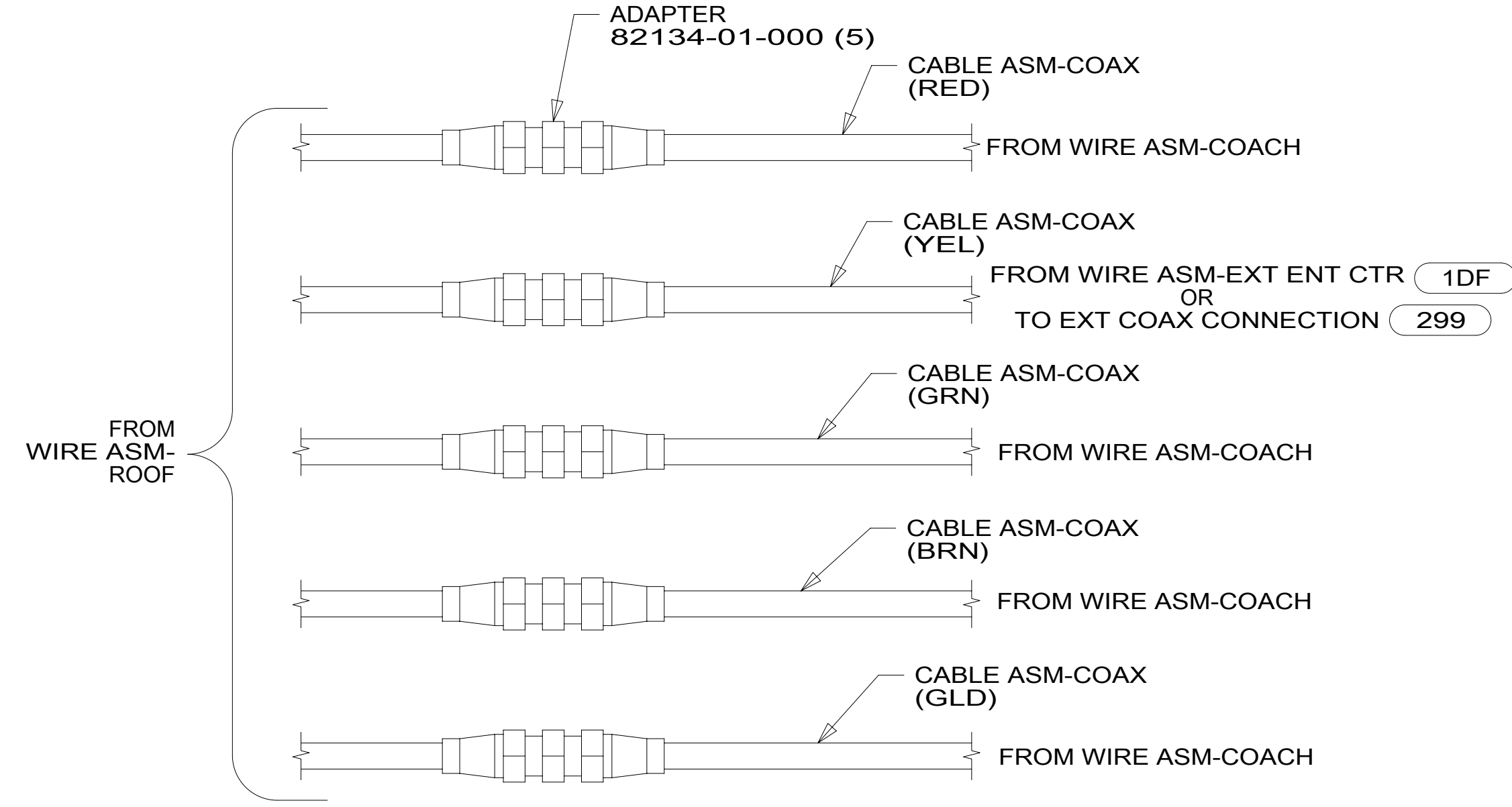

DETAIL DS

ADAPTER  
82134-01-000 (5)

CABLE ASM-COAX (RED)

CABLE ASM-COAX (YEL)

CABLE ASM-COAX (GRN)

CABLE ASM-COAX (BRN)

CABLE ASM-COAX (GLD)

FROM WIRE ASM-COACH

FROM WIRE ASM-EXT ENT CTR 1DF OR TO EXT COAX CONNECTION 299

FROM WIRE ASM-COACH

FROM WIRE ASM-COACH

FROM WIRE ASM-COACH

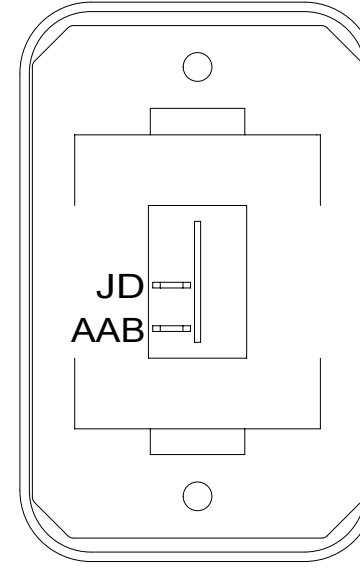

DETAIL DG

SWITCH-ROCKER  
135740-01-CHT  
SWITCH-BASE  
135741-01-CHT  
SWITCH-BEZEL  
135742-01-CHT  
SCREW  
G11-08-08U (2)

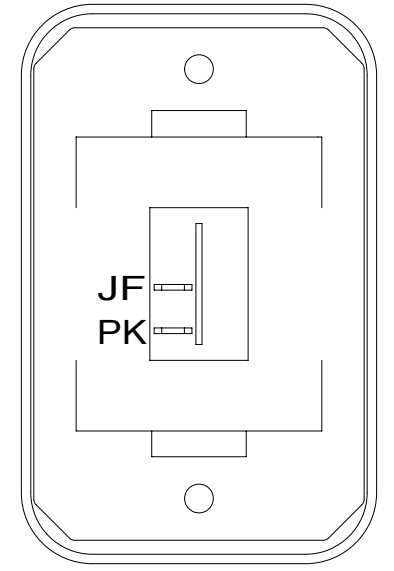

DETAIL DM

SWITCH-ROCKER  
135740-01-CHT  
SWITCH-BASE  
135741-01-CHT  
SWITCH-BEZEL  
135742-01-CHT  
SCREW  
G11-08-08U (2)

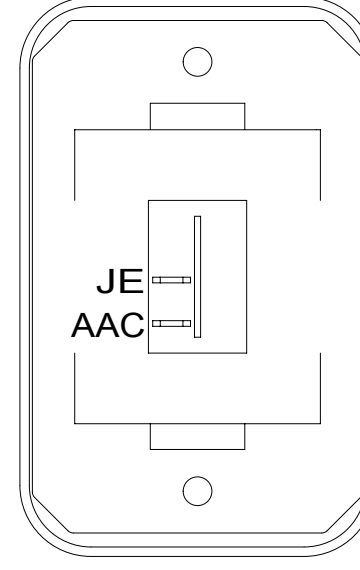

DETAIL DH

SWITCH-ROCKER  
135740-01-CHT  
SWITCH-BASE  
135741-01-CHT  
SWITCH-BEZEL  
135742-01-CHT  
SCREW  
G11-08-08U (2)

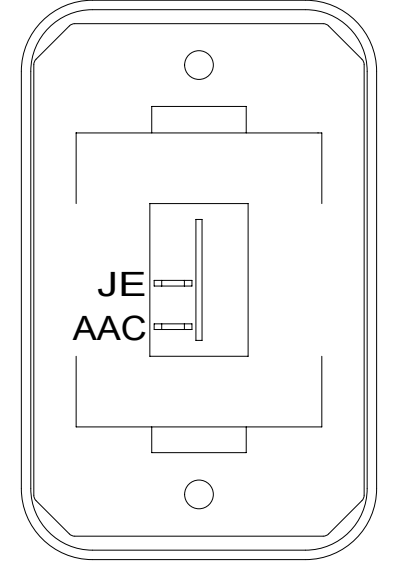

DETAIL DN

SWITCH-ROCKER  
135740-01-CHT  
SWITCH-BASE  
135741-01-CHT  
SWITCH-BEZEL  
135742-01-CHT  
SCREW  
G11-08-08U (2)

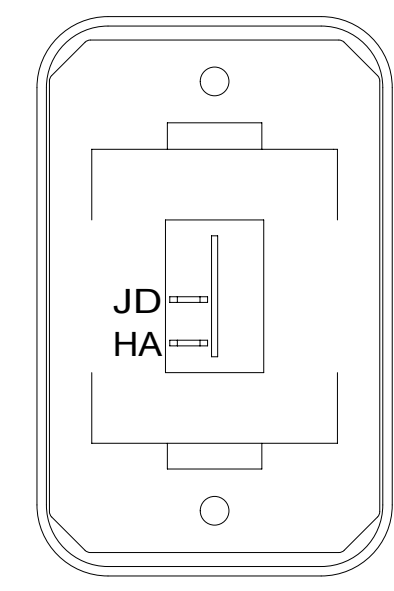

DETAIL DC

SWITCH-ROCKER  
135740-01-CHT  
SWITCH-BASE  
135741-01-CHT  
SWITCH-BEZEL  
135742-01-CHT  
SCREW  
G11-08-08U (2)

NOTES:  
1 FOR SWITCH ORIENTATION SEE DETAIL DD.

FOR ELECTRICAL TORQUE SPECIFICATIONS SEE DWG NO. 128783-01-000

FOR ELECTRICAL CALLOUTS SEE DWG NO. 121339-01-000

- 45B LOFT BED
- 299 ENTERTAINMENT CENTER EXT.W/O
- 1DF EXT TV ENTERTAINMENT CENTER
- 265 CODES/STANDARDS-CSA/CMVSS
- 1B1 CODES/STANDARDS USA

DESCRIPTION: <b>WIRING INSTL-BODY, 12V</b>		
SHEET: 4 OF 6	ITEM/PART NO: 000129354 / 32522401000	REV
12-Jan-2018		

8 7 6 5 4 3 2 1

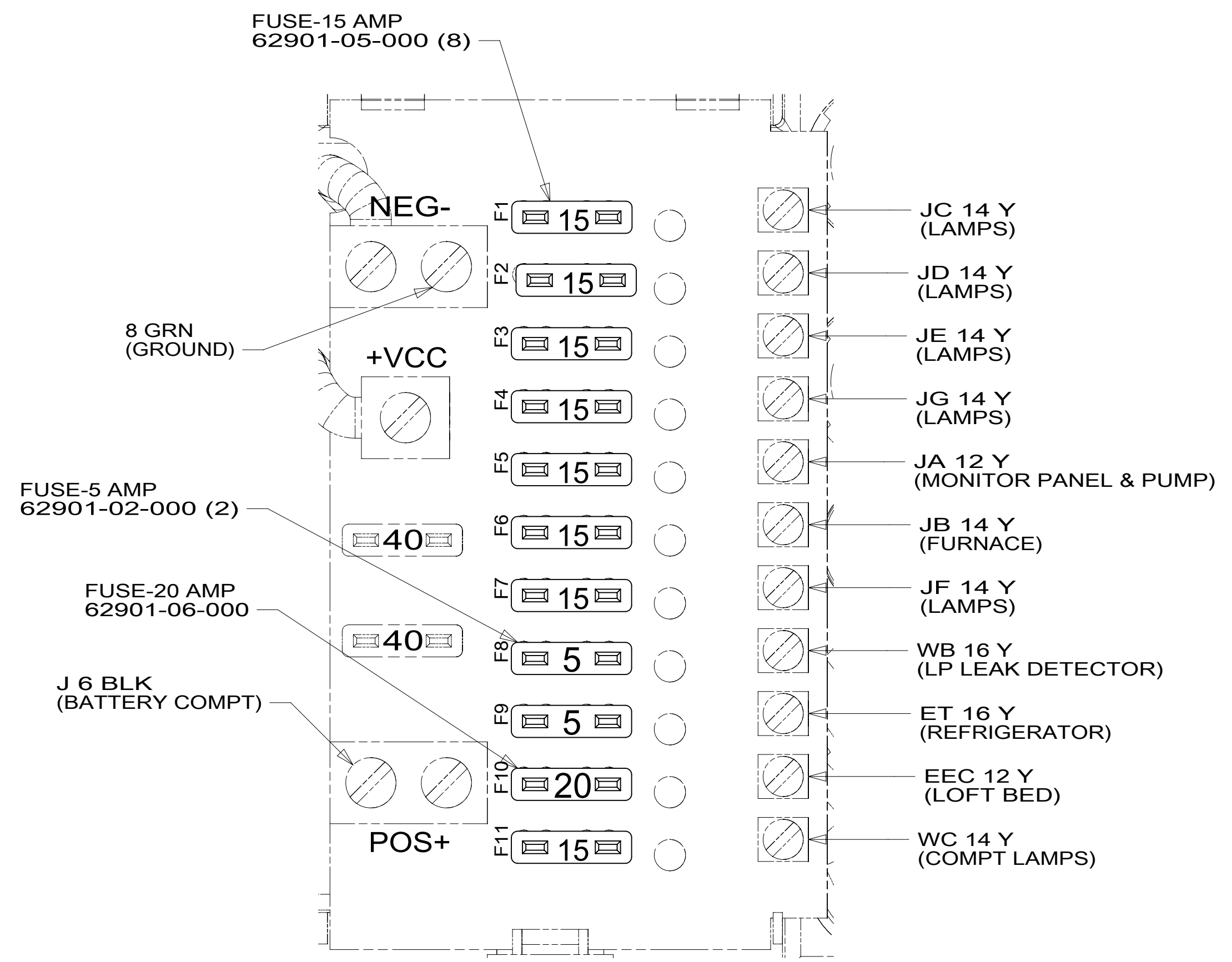
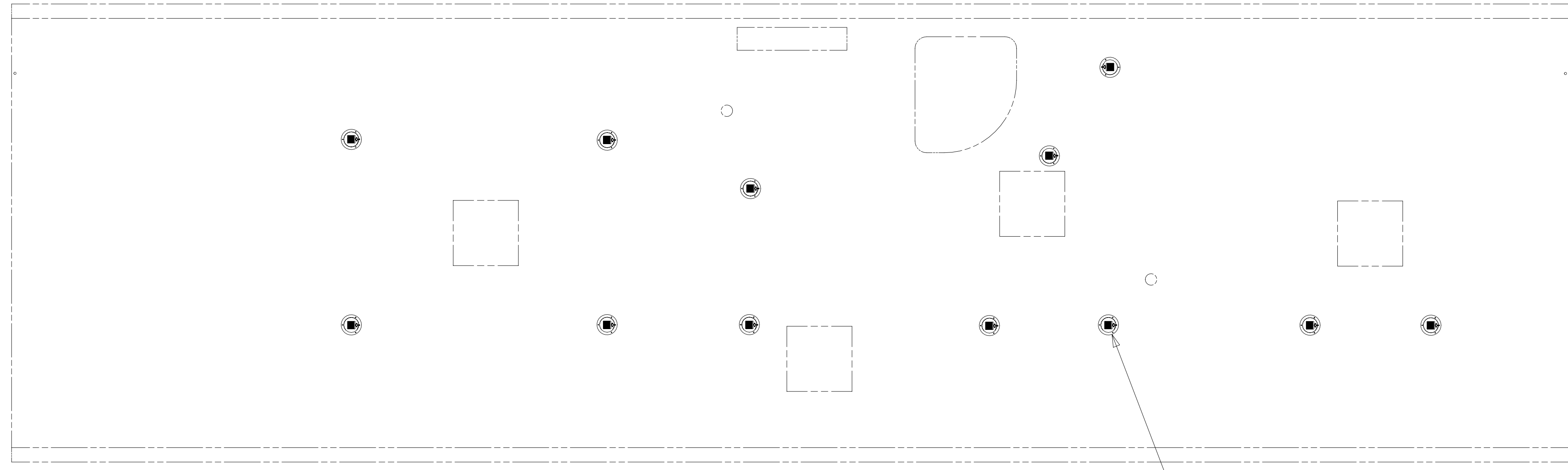

DETAIL EA

- 265 CODES/STANDARDS-CSA/CMVSS
- 1B1 CODES/STANDARDS USA

FOR ELECTRICAL TORQUE SPECIFICATIONS SEE DWG NO. 128783-01-000

FOR ELECTRICAL CALLOUTS SEE DWG NO. 121339-01-000

DESCRIPTION:	
1B1 265	
<b>WIRING INSTL-BODY, 12V</b>	
SHEET:	ITEM/PART NO:
5 OF 6	000129354 / 32522401000
REV	

8 7 6 5 4 3 2 1 12-Jan-2018

8 7 6 5 4 3 2 1

D

D

C

C

B

B

A

A

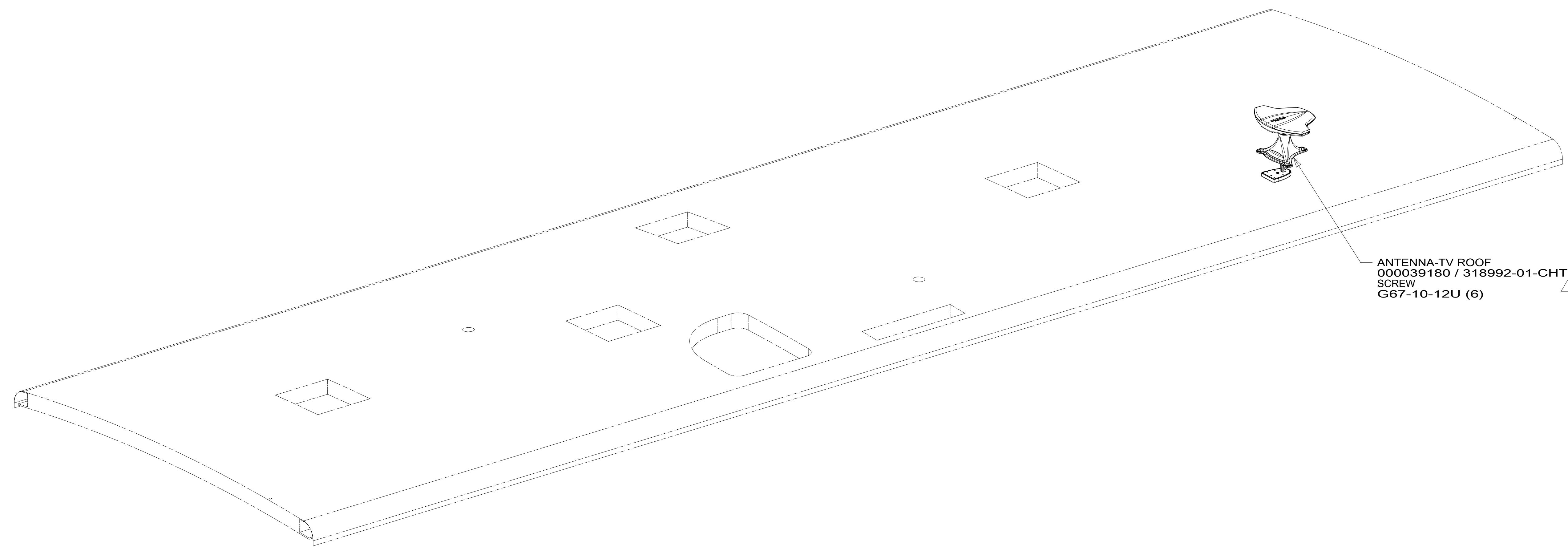

ANTENNA-TV ROOF  
 000039180 / 318992-01-CHT  
 SCREW  
 G67-10-12U (6) 1

1 SEE ANTENNA INSTALLATION MANUAL FOR CORRECT  
 INSTALLATION PROCEDURE.

NOTES:

FOR ELECTRICAL  
 TORQUE  
 SPECIFICATIONS  
 SEE DWG NO.  
 128783-01-000

FOR  
 ELECTRICAL  
 CALLOUTS  
 SEE DWG NO.  
 121339-01-000

265 CODES/STANDARDS-CSA/CMVSS  
1B1 CODES/STANDARDS USA

1B1 265

DESCRIPTION:  
**WIRING INSTL-BODY, 12V**

SHEET: <b>6 OF 6</b>	ITEM/PART NO.: <b>000129354 / 32522401000</b>	REV
-------------------------	--	-----

8 7 6 5 4 3 2 1 12-Jan-2018