

4 PIN HSG FROM WIRE ASM-CHASSIS CIRCUITS: ABY, ABZ, DR, DU
 2 PIN HSG FROM WIRE ASM-CHASSIS CIRCUIT: DDJ
 6 PIN HSG FROM WIRE ASM-CHASSIS W/YEL TAPE

4 PIN HSG FROM WIRE ASM-CHASSIS CIRCUITS: LLL, LLK
 6 PIN HSG FROM WIRE ASM-CHASSIS W/YEL TAPE

4 PIN HSG FROM WIRE ASM-COACH CIRCUITS: ACC, ACD, HHG, HHH
 2 PIN HSG FROM WIRE ASM-COACH CIRCUIT: DDJ

2 PIN HSG FROM WIRE ASM-COACH CIRCUITS: XXW, XXV

DETAIL AB

DETAIL AC

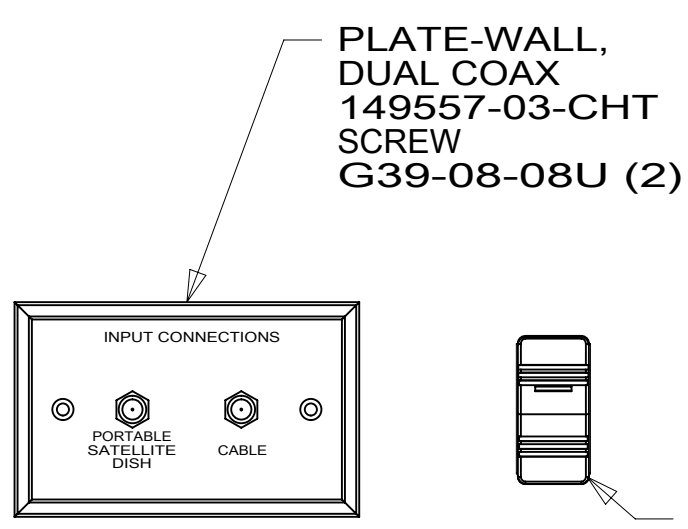

SWITCH-WATER PUMP
 108357-15-CHT ACTUATOR
 108356-03-CHT CIRCUITS
 AG, JA, AF, JS, JY

VIEW AA

WIRE ASM-AUX HOLDING TANK 151316-01-000
 WIRE ASM-WATER TANK 151317-01-000
 SWITCH-DRAIN PUMP 108357-09-000 ACTUATOR 108356-01-CHT
 WIRE ASM-MAIN HOLDING TANK 151317-01-000

PANEL-SERVICE 132862-08-CHT SCREW G39-10-12U (4)
 CONTROL-SLIDEOUT 189400-01-000
 COVER-ELECTRICAL 194965-01-CHT

LABEL-SLIDEOUT CTL, BLK W/WHT 098379-09-000

PANEL-SERVICE 132862-08-CHT SCREW G39-10-12U (4)

PANEL-RECEPTACLE 151376-01-CHT SCREW G67-10-12U (4)
 PANEL-RECEPTACLE 151376-02-CHT LABEL-COAX 157486-01-CHT ADAPTER 82134-01-000 NUT 82136-01-000 SCREW G67-10-12U (4)

PANEL-CLOSEOUT 146424-28-CHT SCREW G11-08-12U (6)

WIRE ASM-MAIN HOLDING TANK 151317-01-000

DA, PM TO DRAIN PUMP

WIRE ASM-COACH 000128888 / 325094-01-000

LABEL-SLIDEOUT CTL, BLK W/WHT 098379-09-000

CONTROL-SLIDEOUT 189400-01-000
 DETAIL AC

COVER-ELECTRICAL 194965-01-CHT

PANEL-SERVICE 132862-08-CHT SCREW G39-10-12U (4)

2 PIN HSG TO WATER PUMP

- 299 ENTERTAINMENT CENTER EXT. W/O
- 1D3 ENTERTAIN CENTR/EXT TV-DVD
- 265 CODES/STANDARDS-CSA/CMVSS
- 1B1 CODES/STANDARDS USA

WINNEBAGO
 COPYRIGHT 2016 WINNEBAGO INDUSTRIES, INC.

DSNR:	ALL DIMENSIONS ARE IN MILLIMETERS
DIFTR:	MATERIAL:
UNSPECIFIED TOLERANCES:	
WHOLE DIM (X)	3
ONE-PLACE (X.X)	1.5
TWO-PLACE (X.XX)	0.50
ANGLE	1°
REFER TO ES0018 FOR FASTENER TIGHTENING GUIDELINES	WEIGHT: (LBS) FIRST USED: 18 E35F
DESCRIPTION:	
WIRING INSTL-BODY, 12V	
SHEET: 1 OF 8	ITEM/PART NO: 000128362 / 32496201000
REF:	

- 4 WIRE PASSES THROUGH FLOOR IN THIS AREA.
 3 PLACE CROSS LOCATOR ON SENSORS OVER DIMPLES ON TANK.
- ROUTE TANK SENSOR WIRES SO THEY DO NOT PASS OVER SENSORS. USE WIRE TIE MOUNT 155366-01-000 AND WIRE TIE 8343-01-000 AS NEEDED. TANK SURFACE MUST BE CLEANED USING ISOPROPYL ALCOHOL AND PRIMED WITH PRIMER 94.
 - AT MINIMUM ALL WIRES TO BE SUPPORTED AND SECURED PER CODE REQUIREMENTS. USE CLAMP 10495 OR 10497 OR WIRE TIE 8343 OR 108046 AND SCREW G67-XX-XXX OR G56-XX-XXX AS APPROPRIATE FOR INSTALLATION.

FOR ELECTRICAL TORQUE SPECIFICATIONS SEE DWG NO. 128783-01-000

FOR ELECTRICAL CALLOUTS SEE DWG NO. 121339-01-000

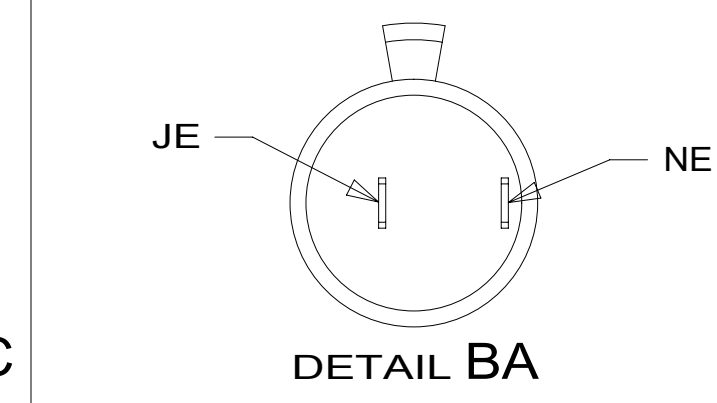
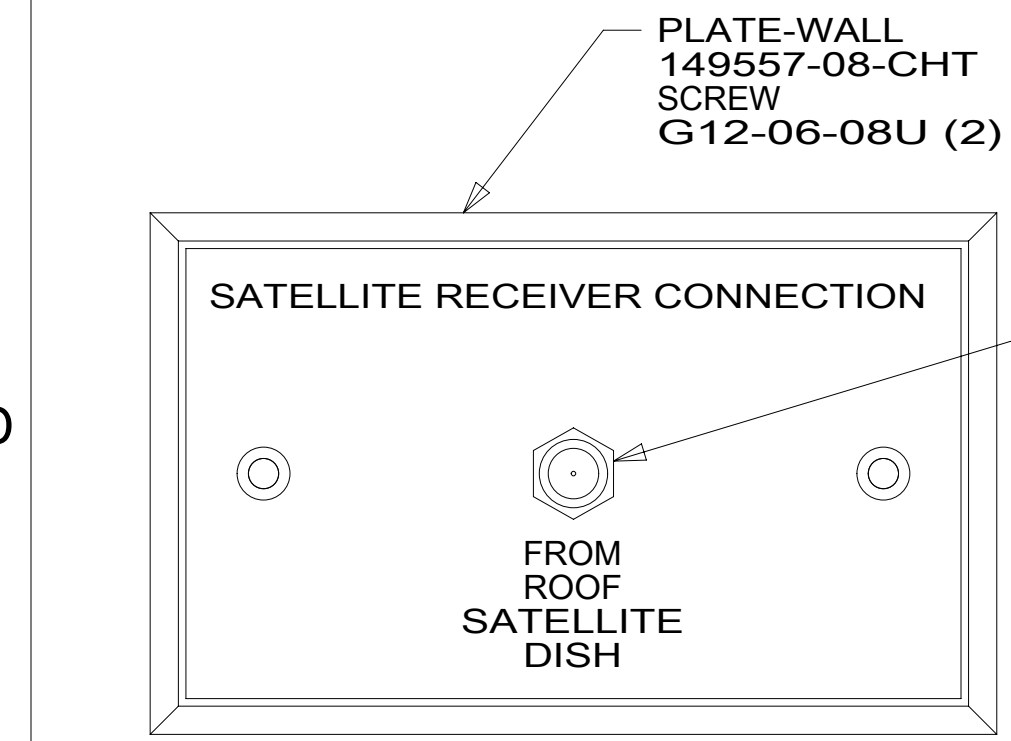
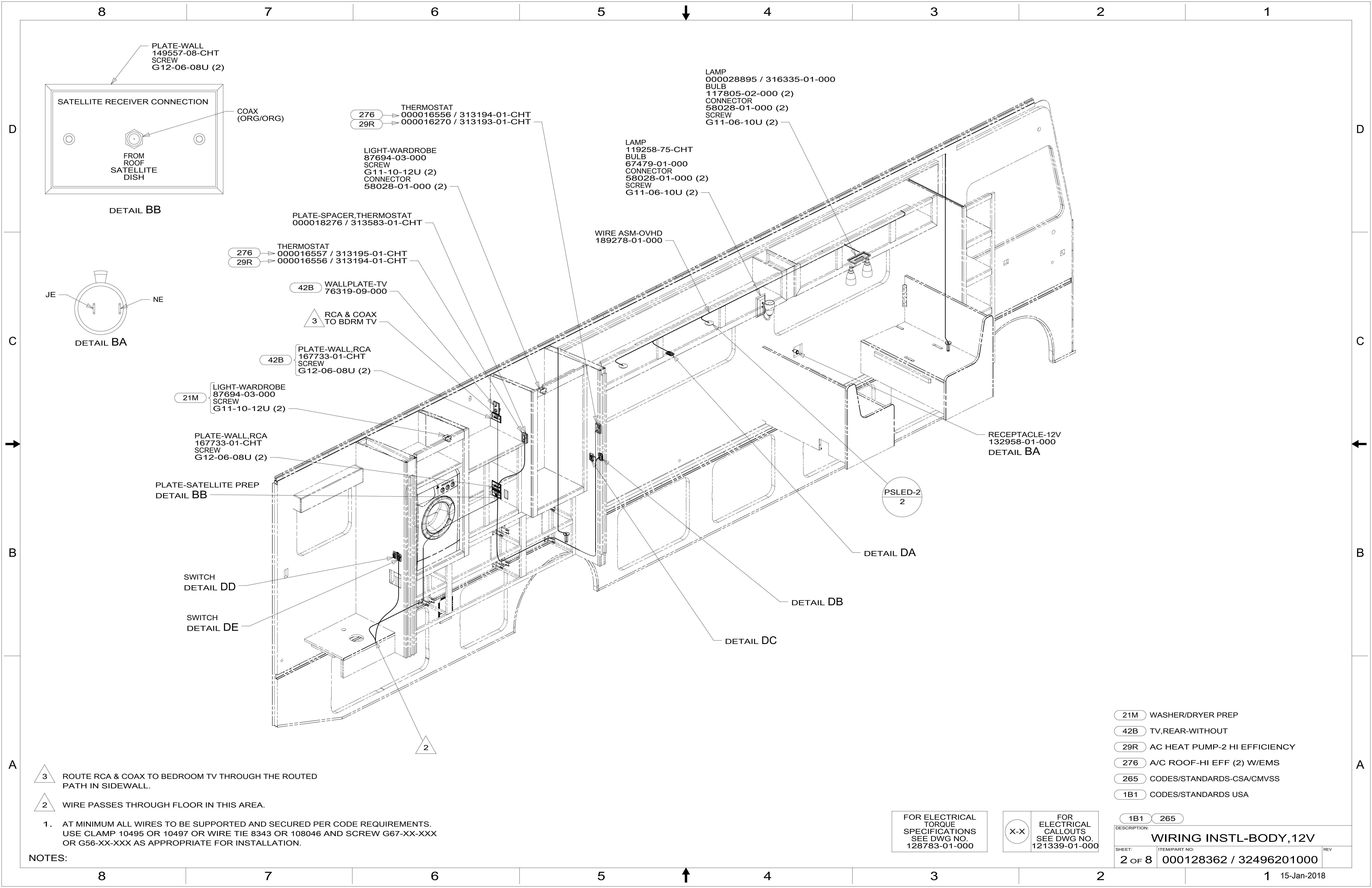

- 3 ROUTE RCA & COAX TO BEDROOM TV THROUGH THE ROUTED PATH IN SIDEWALL.
- 2 WIRE PASSES THROUGH FLOOR IN THIS AREA.

NOTES:
 1. AT MINIMUM ALL WIRES TO BE SUPPORTED AND SECURED PER CODE REQUIREMENTS. USE CLAMP 10495 OR 10497 OR WIRE TIE 8343 OR 108046 AND SCREW G67-XX-XXX OR G56-XX-XXX AS APPROPRIATE FOR INSTALLATION.

- 21M WASHER/DRYER PREP
- 42B TV, REAR-WITHOUT
- 29R AC HEAT PUMP-2 HI EFFICIENCY
- 276 A/C ROOF-HI EFF (2) W/EMS
- 265 CODES/STANDARDS-CSA/CMVSS
- 1B1 CODES/STANDARDS USA

FOR ELECTRICAL TORQUE SPECIFICATIONS SEE DWG NO. 128783-01-000

FOR ELECTRICAL CALLOUTS SEE DWG NO. 121339-01-000

DESCRIPTION:		1B1 265	
WIRING INSTL-BODY, 12V			
SHEET:	ITEM/PART NO.:	REV:	
2 OF 8	000128362 / 32496201000		

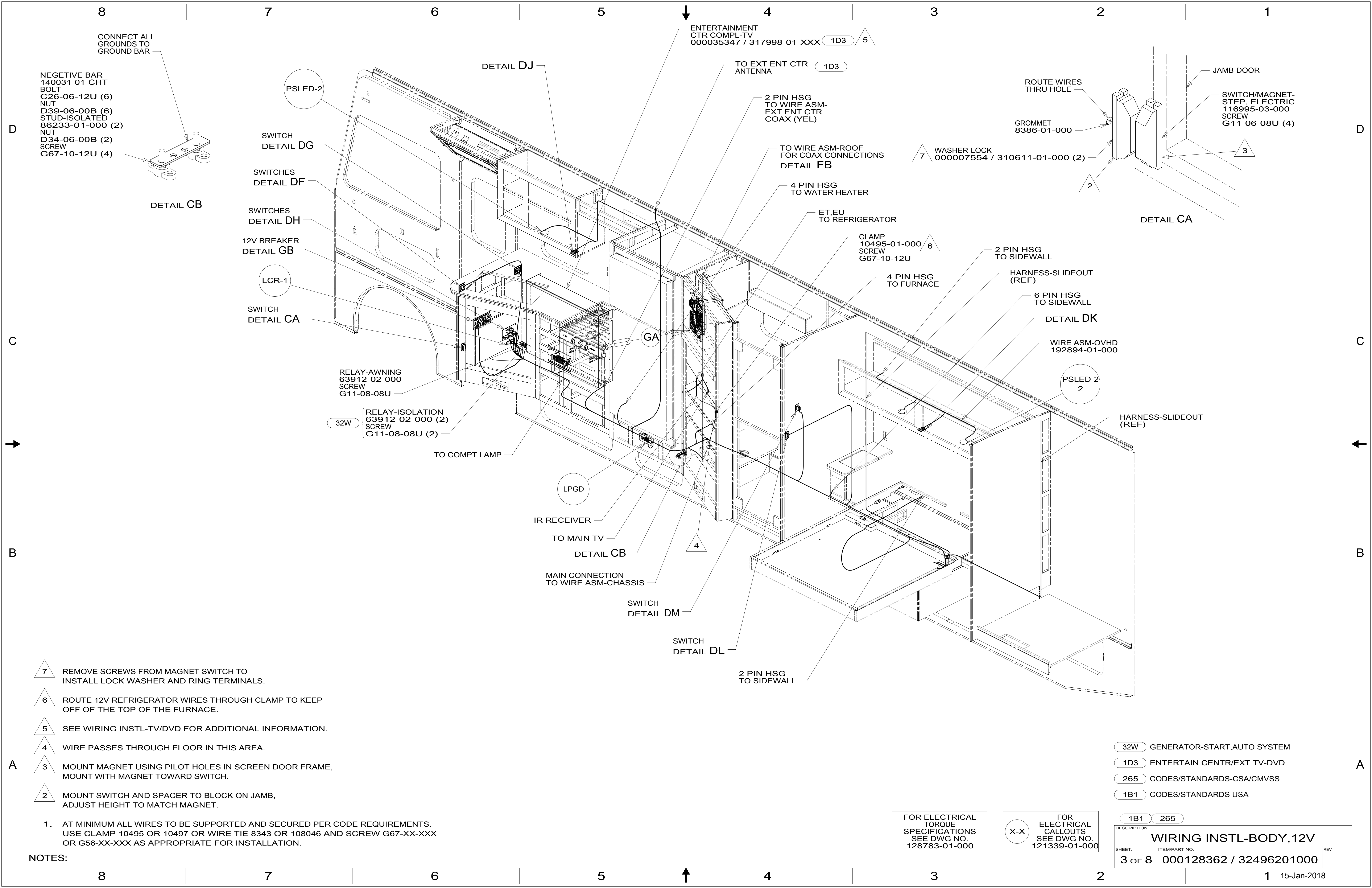

- 7 REMOVE SCREWS FROM MAGNET SWITCH TO INSTALL LOCK WASHER AND RING TERMINALS.
- 6 ROUTE 12V REFRIGERATOR WIRES THROUGH CLAMP TO KEEP OFF OF THE TOP OF THE FURNACE.
- 5 SEE WIRING INSTL-TV/DVD FOR ADDITIONAL INFORMATION.
- 4 WIRE PASSES THROUGH FLOOR IN THIS AREA.
- 3 MOUNT MAGNET USING PILOT HOLES IN SCREEN DOOR FRAME, MOUNT WITH MAGNET TOWARD SWITCH.
- 2 MOUNT SWITCH AND SPACER TO BLOCK ON JAMB, ADJUST HEIGHT TO MATCH MAGNET.

1. AT MINIMUM ALL WIRES TO BE SUPPORTED AND SECURED PER CODE REQUIREMENTS. USE CLAMP 10495 OR 10497 OR WIRE TIE 8343 OR 108046 AND SCREW G67-XX-XXX OR G56-XX-XXX AS APPROPRIATE FOR INSTALLATION.

NOTES:

FOR ELECTRICAL TORQUE SPECIFICATIONS SEE DWG NO. 128783-01-000

FOR ELECTRICAL CALLOUTS SEE DWG NO. 121339-01-000

- 32W GENERATOR-START,AUTO SYSTEM
- 1D3 ENTERTAIN CENTR/EXT TV-DVD
- 265 CODES/STANDARDS-CSA/CMVSS
- 1B1 CODES/STANDARDS USA

DESCRIPTION: WIRING INSTL-BODY, 12V	
SHEET: 3 OF 8	ITEM/PART NO: 000128362 / 32496201000
REV 15-Jan-2018	

D

C

B

A

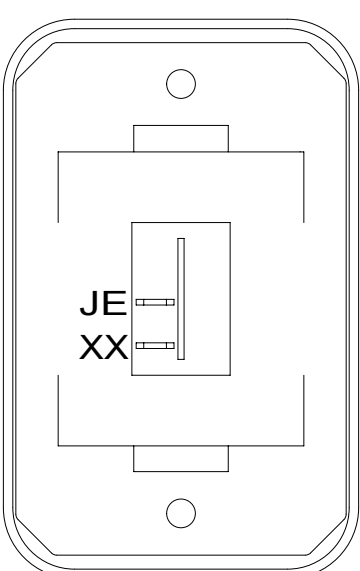

SWITCH-ROCKER
135740-01-CHT
SWITCH-BASE
135741-01-CHT
SWITCH-BEZEL
135742-01-CHT
SCREW
G11-08-08U (2)

DETAIL DA

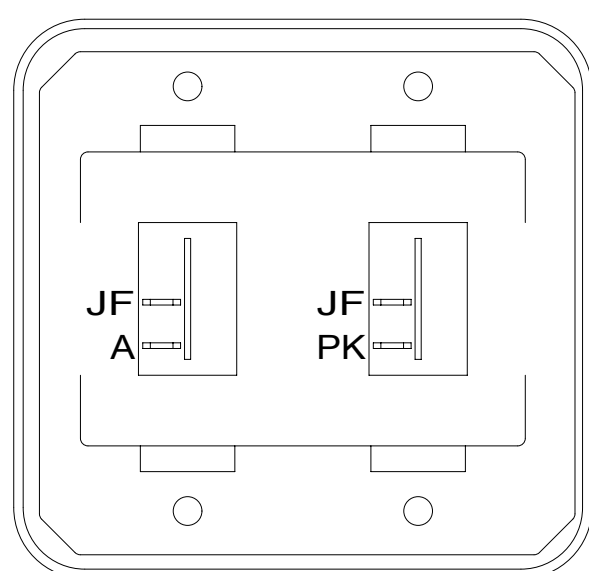

SWITCH-ROCKER
135740-01-CHT (2)
SWITCH-BASE
135741-02-CHT
SWITCH-BEZEL
135742-02-CHT
SCREW
G11-08-08U (4)

DETAIL DF

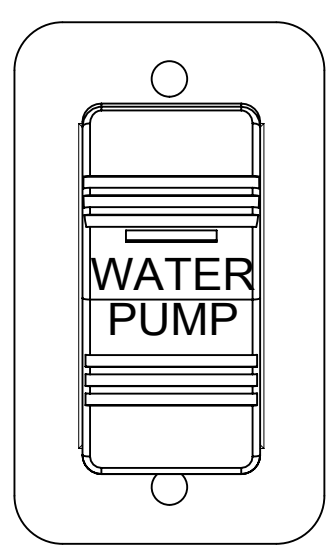

SWITCH-PUMP
108357-15-000
ACTUATOR
108356-23-CHT
PLATE
98351-07-CHT
SCREW
G11-06-10U (2)

DETAIL DM

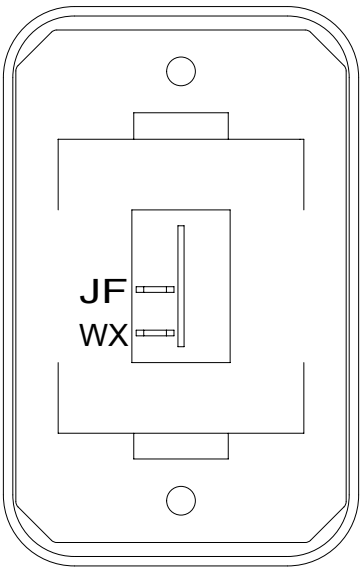

SWITCH-ROCKER
135740-01-CHT
SWITCH-BASE
135741-01-CHT
SWITCH-BEZEL
135742-01-CHT
SCREW
G11-08-08U (2)

DETAIL DB

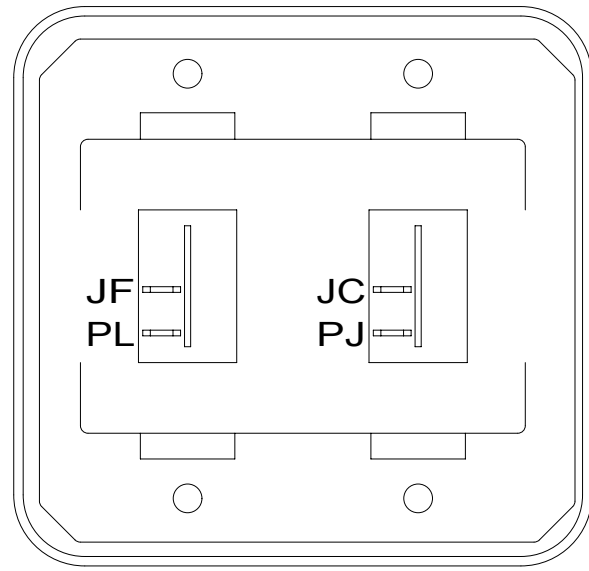

SWITCH-ROCKER
135740-01-CHT (2)
SWITCH-BASE
135741-02-CHT
SWITCH-BEZEL
135742-02-CHT
SCREW
G11-08-08U (4)

DETAIL DG

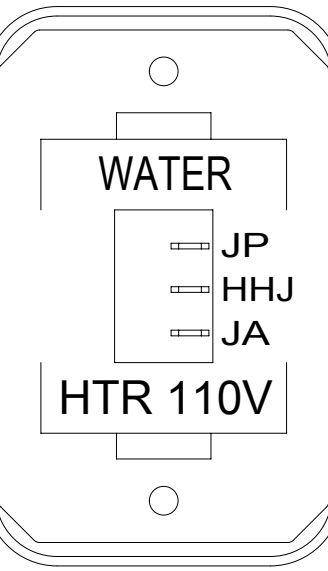

SWITCH-ROCKER
135740-06-CHT
SWITCH-BASE
135741-01-CHT
SWITCH-BEZEL
135742-35-CHT
SCREW
G11-08-08U (2)

DETAIL DP

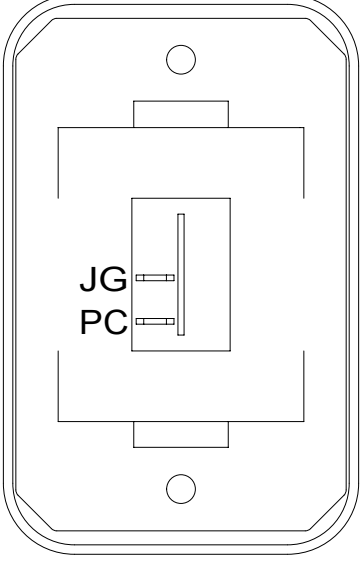

SWITCH-ROCKER
135740-01-CHT
SWITCH-BASE
135741-01-CHT
SWITCH-BEZEL
135742-01-CHT
SCREW
G11-08-08U (2)

DETAIL DC

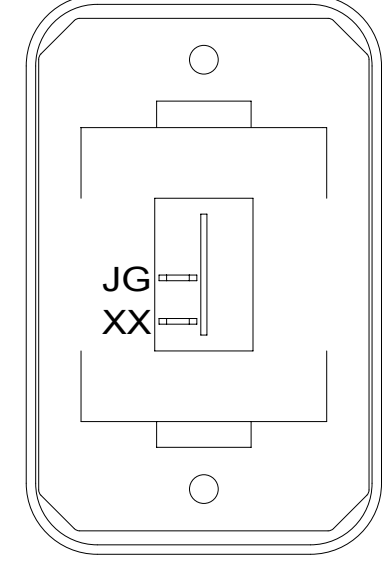

SWITCH-ROCKER
135740-01-CHT
SWITCH-BASE
135741-01-CHT
SWITCH-BEZEL
135742-01-CHT
SCREW
G11-08-08U (2)

DETAIL DJ

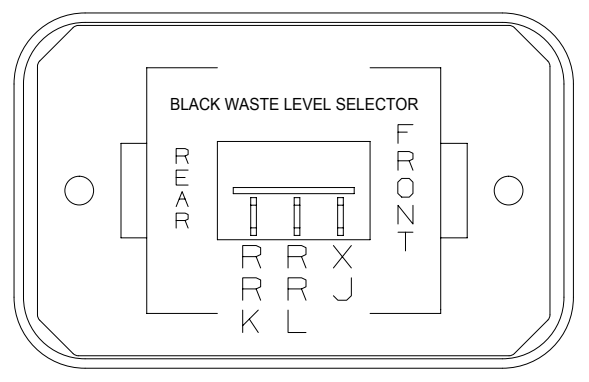

SWITCH-ROCKER
135740-02-CHT
SWITCH-BASE
135741-01-CHT
SWITCH-BEZEL
135742-61-CHT
SCREW
G11-08-08U (2)

DETAIL DR

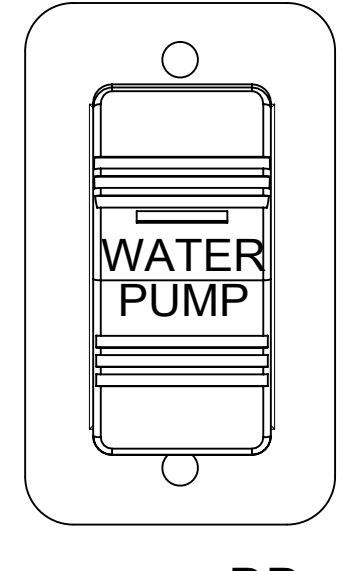

SWITCH-PUMP
108357-15-000
ACTUATOR
108356-23-CHT
PLATE
98351-07-CHT
SCREW
G11-06-10U (2)

DETAIL DD

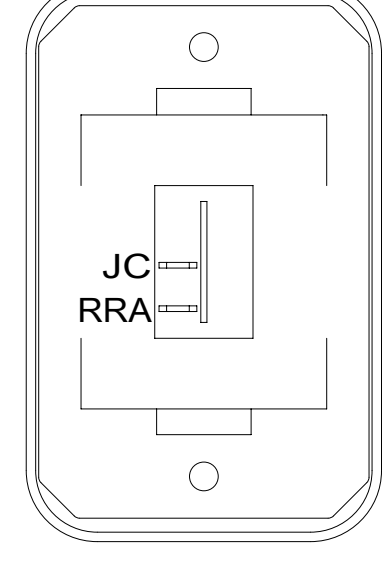

SWITCH-ROCKER
135740-01-CHT
SWITCH-BASE
135741-01-CHT
SWITCH-BEZEL
135742-01-CHT
SCREW
G11-08-08U (2)

DETAIL DK

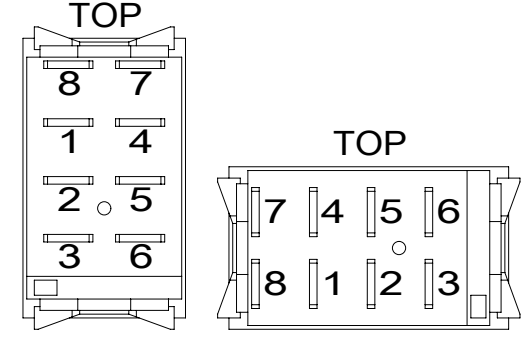

DETAIL DS

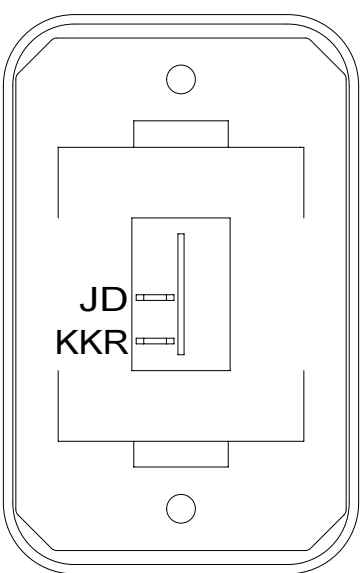

SWITCH-ROCKER
135740-01-CHT
SWITCH-BASE
135741-01-CHT
SWITCH-BEZEL
135742-01-CHT
SCREW
G11-08-08U (2)

DETAIL DE

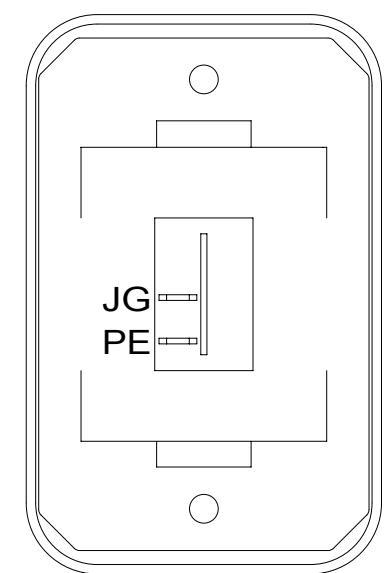

SWITCH-ROCKER
135740-01-CHT
SWITCH-BASE
135741-01-CHT
SWITCH-BEZEL
135742-01-CHT
SCREW
G11-08-08U (2)

DETAIL DL

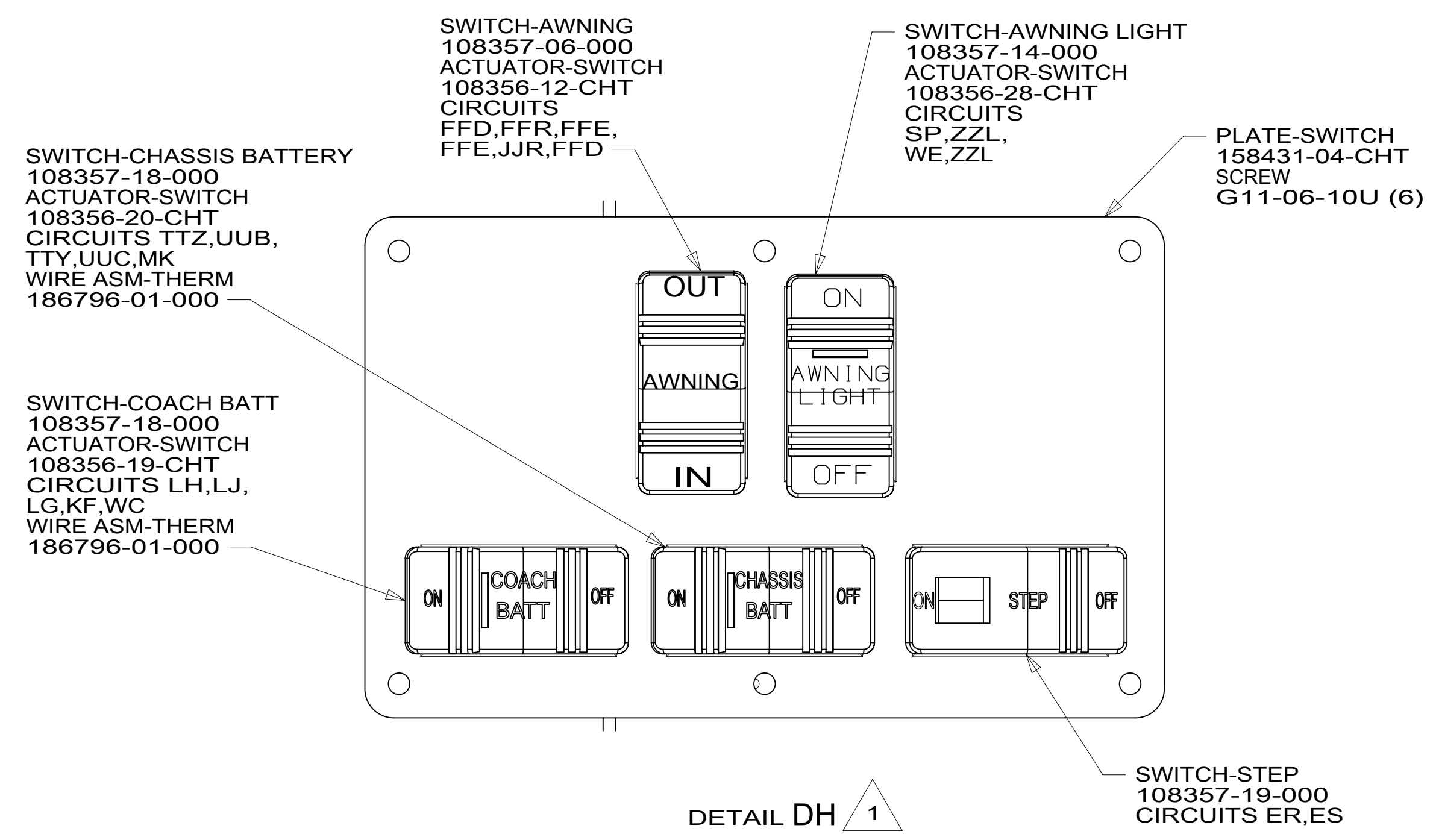

DETAIL DH 1

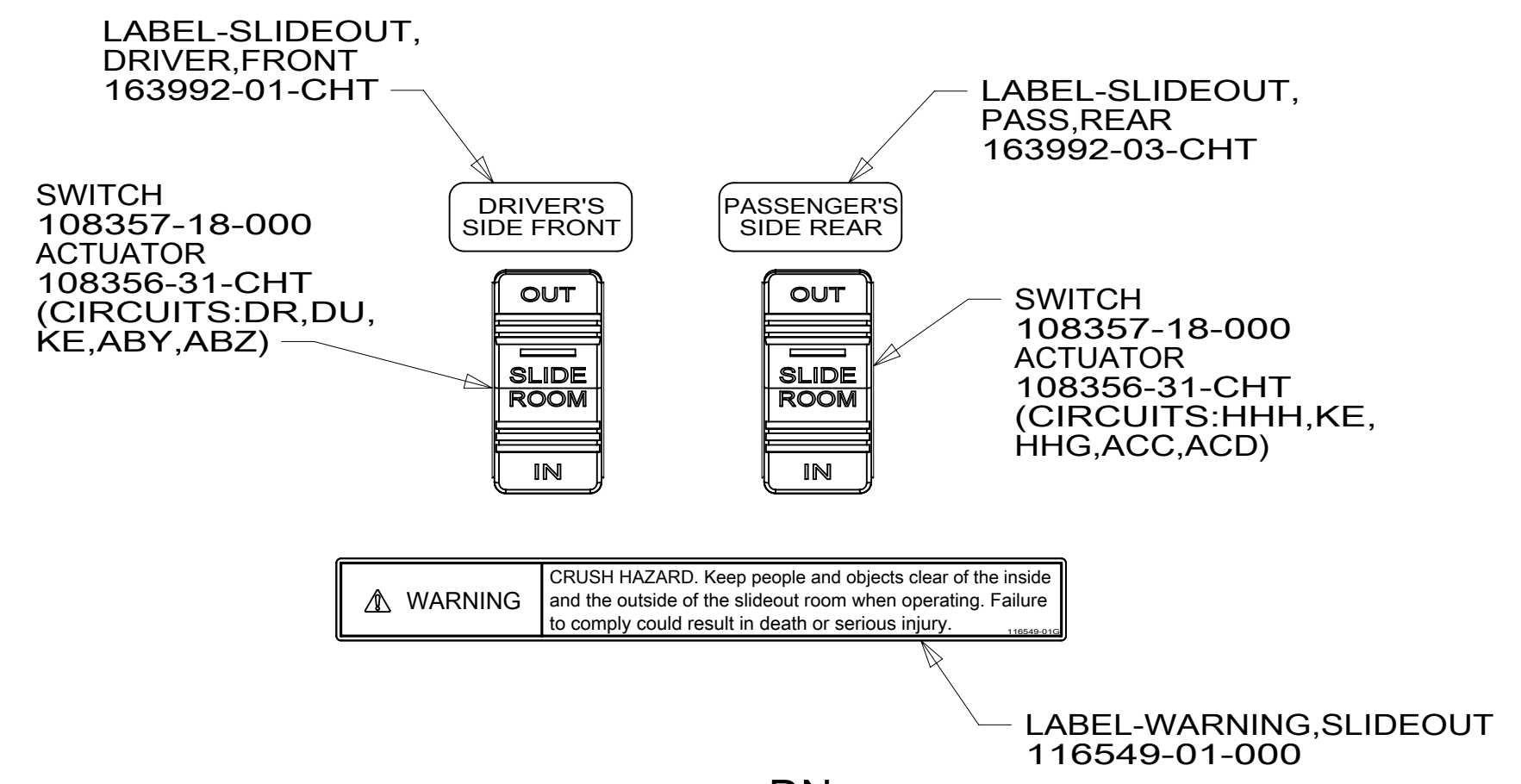

DETAIL DN

NOTES:
1 FOR SWITCH ORIENTATION SEE DETAIL DS

FOR ELECTRICAL TORQUE SPECIFICATIONS SEE DWG NO. 128783-01-000

FOR ELECTRICAL CALLOUTS SEE DWG NO. 121339-01-000

265 CODES/STANDARDS-CSA/CMVSS
1B1 CODES/STANDARDS USA

DESCRIPTION:	1B1 265	
WIRING INSTL-BODY, 12V		
SHEET:	ITEM/PART NO.:	REV
4 OF 8	000128362 / 32496201000	

8

7

6

5

4

3

2

1

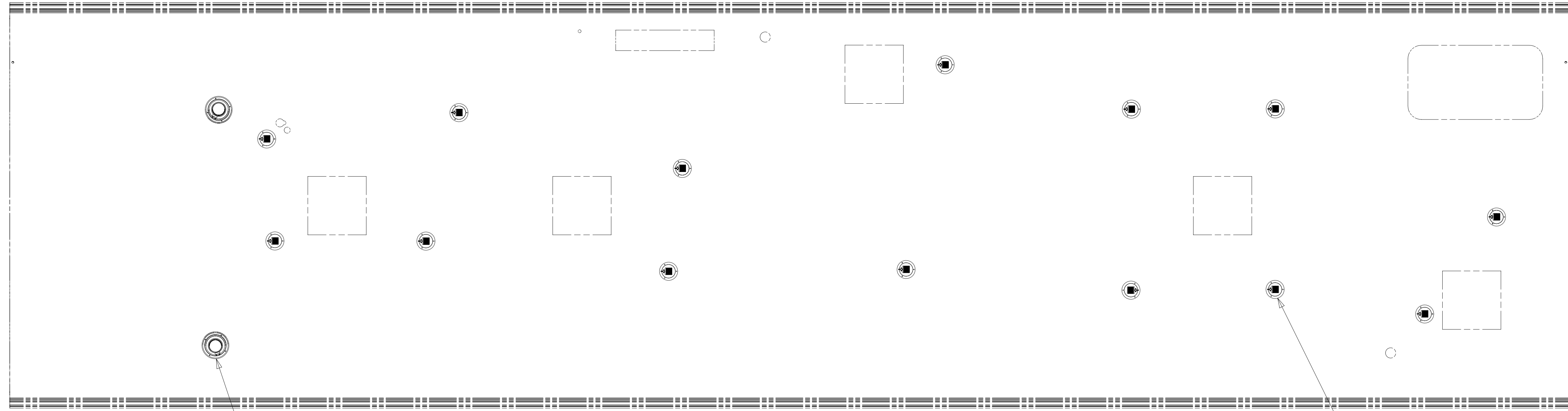

SPEAKER-ROUND,CEILING
 180783-01-CHT (2)
 SCREW
 000G11-08-12U (8)

PRLED-4
 14

D

D

C

C

B

B

A

A



265 CODES/STANDARDS-CSA/CMVSS
 1B1 CODES/STANDARDS USA

FOR ELECTRICAL
 TORQUE
 SPECIFICATIONS
 SEE DWG NO.
 128783-01-000

FOR
 ELECTRICAL
 CALLOUTS
 SEE DWG NO.
 121339-01-000

1B1	265	
DESCRIPTION: WIRING INSTL-BODY, 12V		
SHEET: 5 OF 8	ITEM/PART NO: 000128362 / 32496201000	REV

8

7

6

5

4

3

2

1



15-Jan-2018

8 7 6 5 4 3 2 1

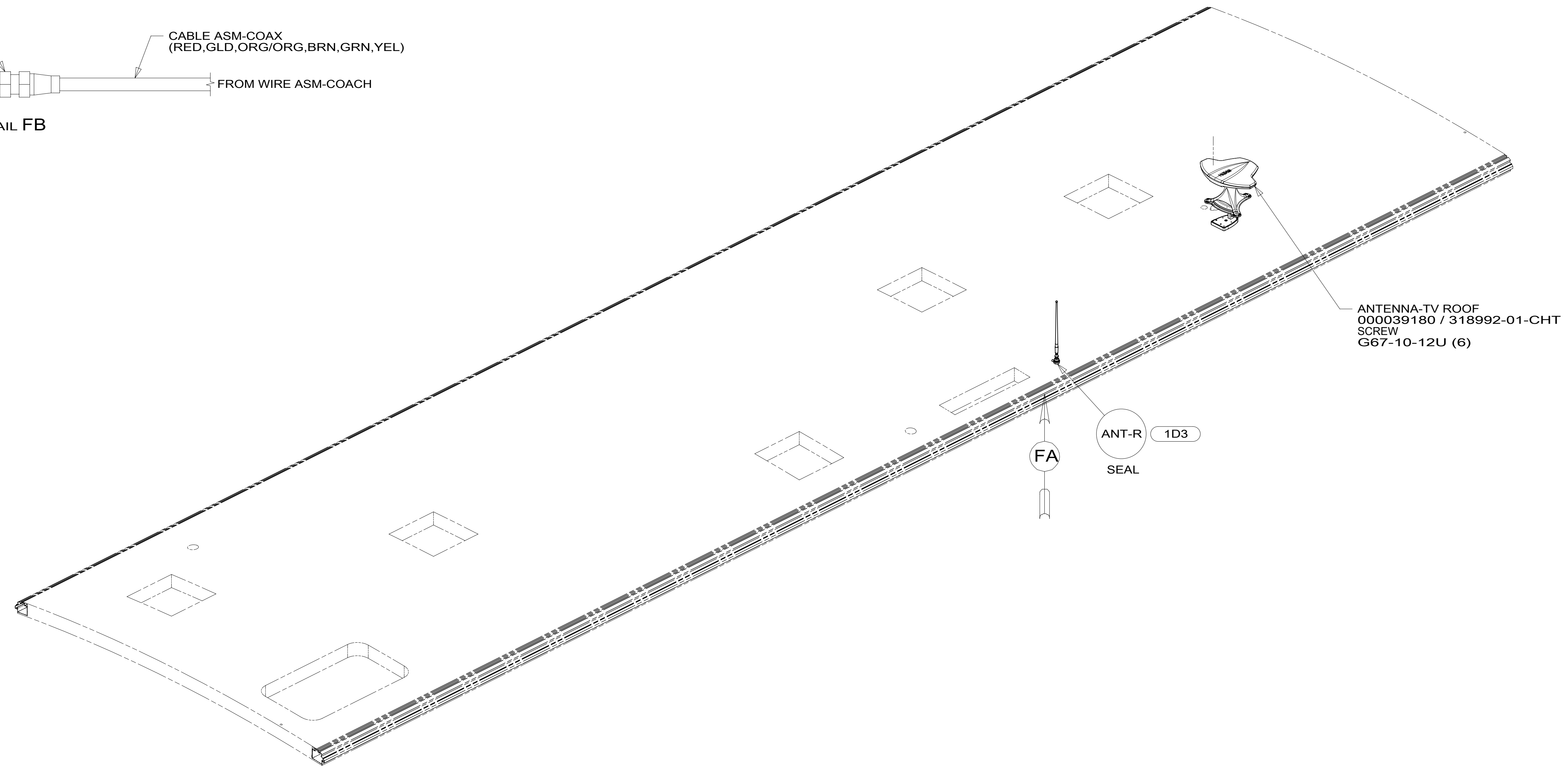
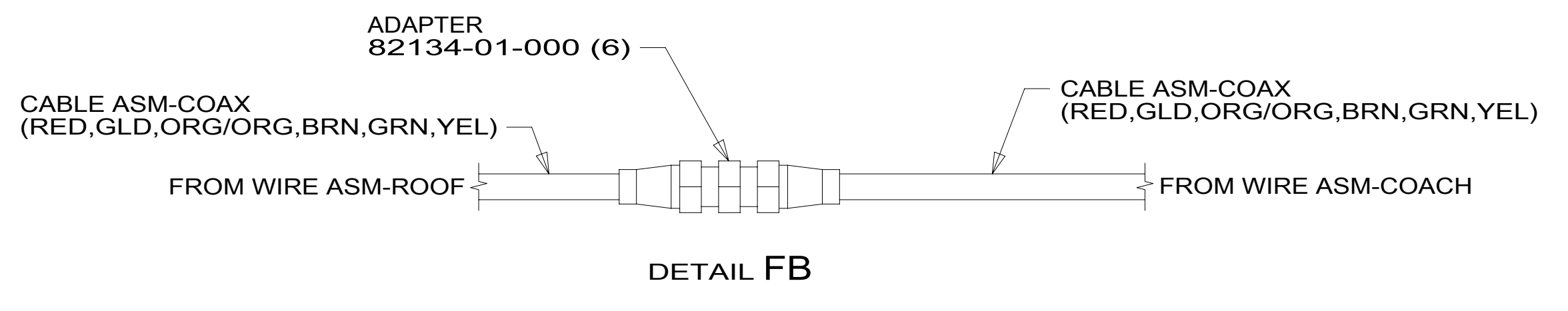
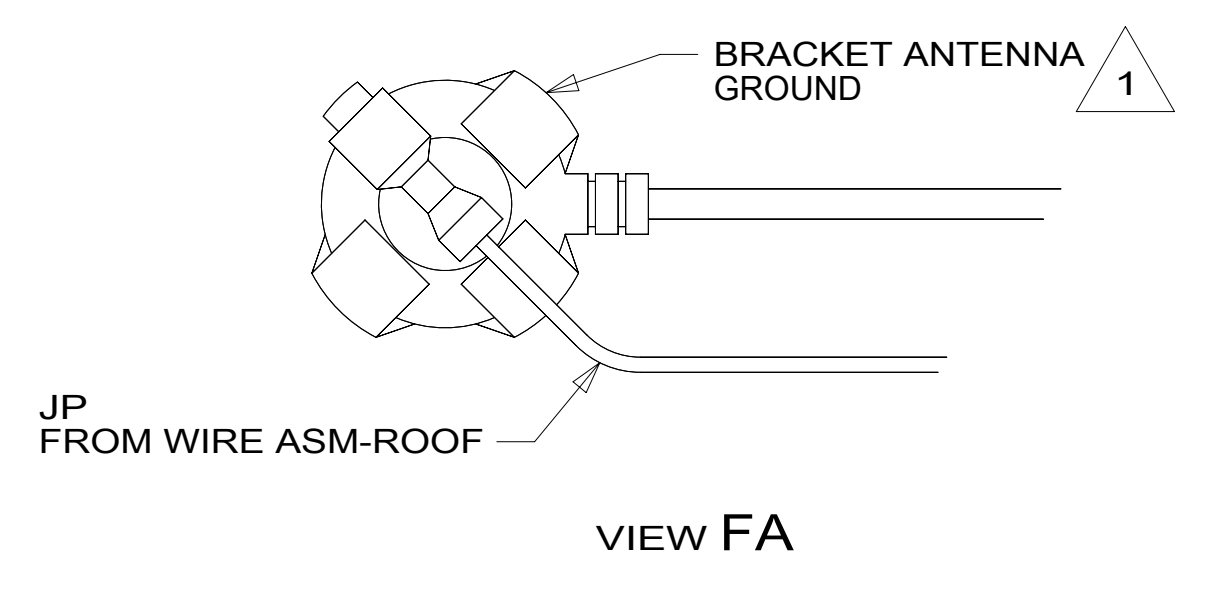

NOTES:

1 WRAP LEGS AROUND ANTENNA BASE.

FOR ELECTRICAL TORQUE SPECIFICATIONS SEE DWG NO. 128783-01-000

FOR ELECTRICAL CALLOUTS SEE DWG NO. 121339-01-000

- 1D3 ENTERTAIN CENTR/EXT TV-DVD
- 265 CODES/STANDARDS-CSA/CMVSS
- 1B1 CODES/STANDARDS USA

DESCRIPTION: WIRING INSTL-BODY, 12V		
SHEET: 6 OF 8	ITEM/PART NO.: 000128362 / 32496201000	REV

8 7 6 5 4 3 2 1 15-Jan-2018

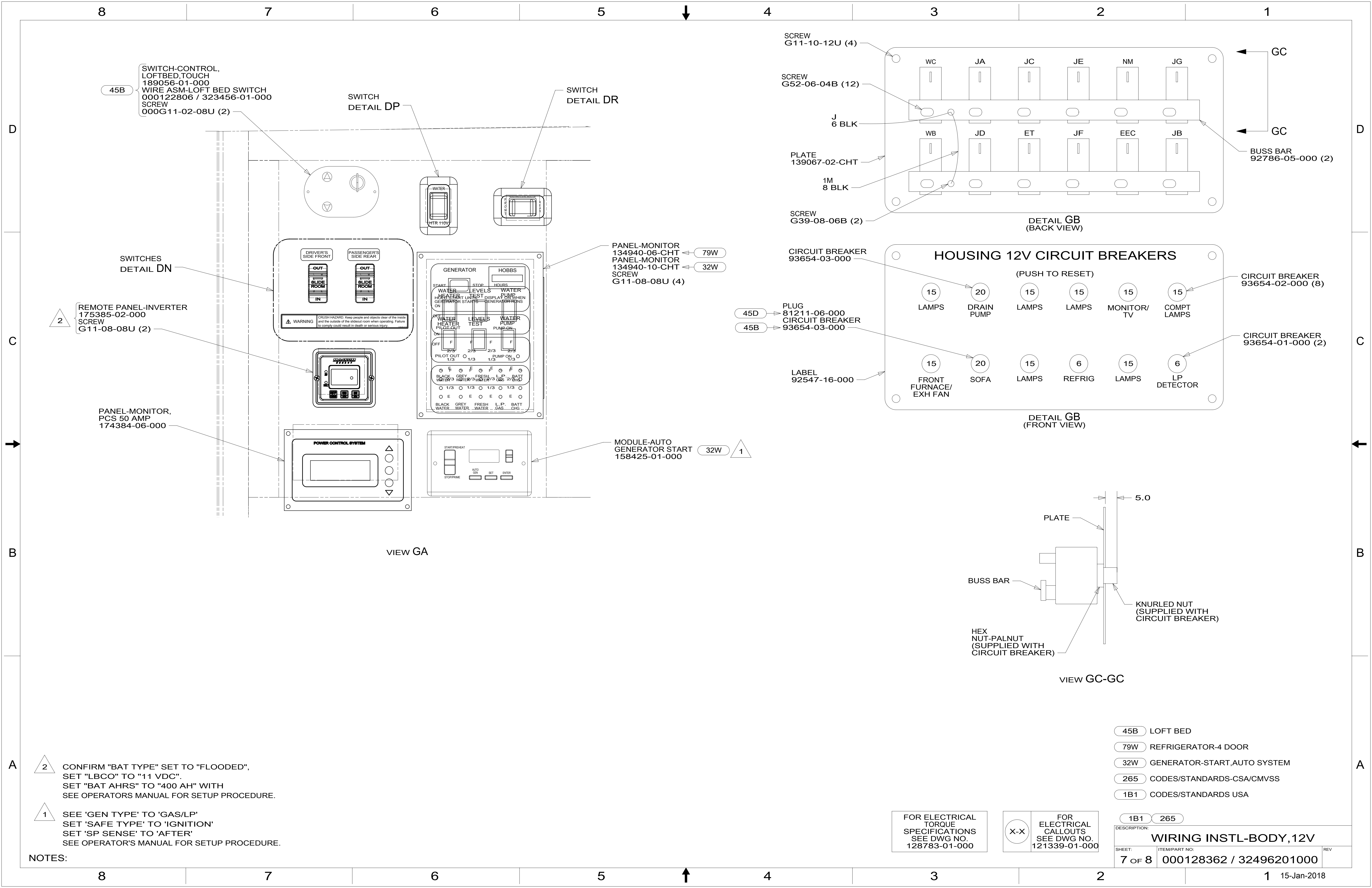

SWITCH-CONTROL, LOFTBED, TOUCH
189056-01-000
WIRE ASM-LOFT BED SWITCH
000122806 / 323456-01-000
SCREW
000G11-02-08U (2)

SWITCH
DETAIL DP

SWITCH
DETAIL DR

SCREW
G11-10-12U (4)

SCREW
G52-06-04B (12)

J
6 BLK

PLATE
139067-02-CHT

1M
8 BLK

SCREW
G39-08-06B (2)

DETAIL GB
(BACK VIEW)

SWITCHES
DETAIL DN

REMOTE PANEL-INVERTER
175385-02-000
SCREW
G11-08-08U (2)

PANEL-MONITOR
134940-06-CHT 79W
PANEL-MONITOR
134940-10-CHT 32W
SCREW
G11-08-08U (4)

PLUG
81211-06-000

45D
45B
CIRCUIT BREAKER
93654-03-000

HOUSING 12V CIRCUIT BREAKERS

(PUSH TO RESET)

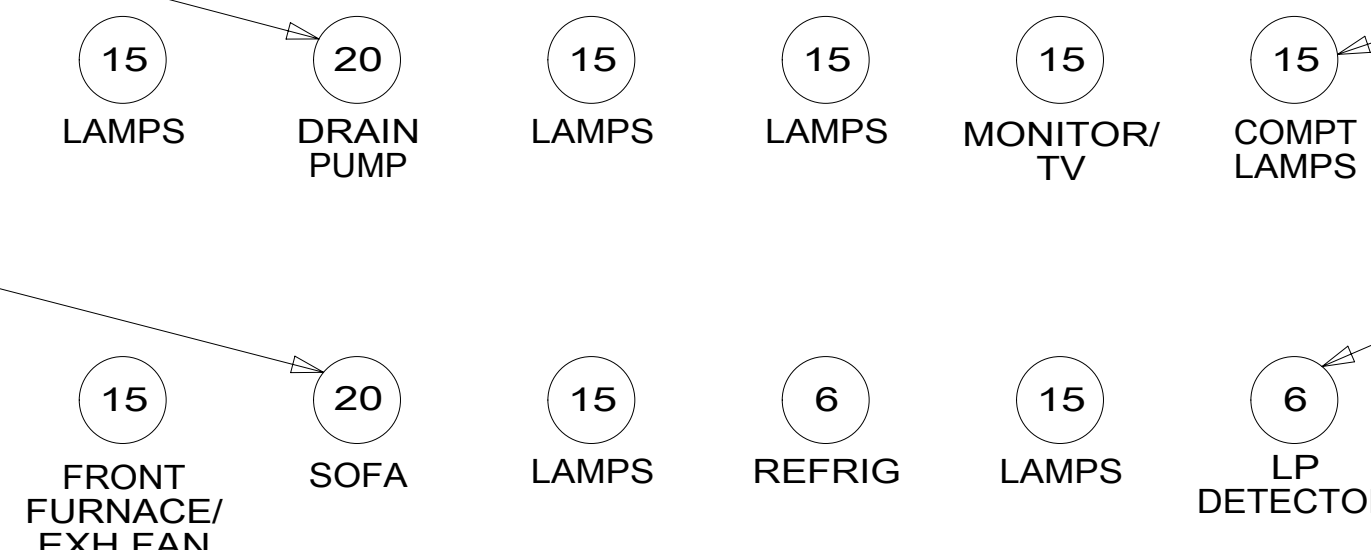

CIRCUIT BREAKER
93654-02-000 (8)

CIRCUIT BREAKER
93654-01-000 (2)

DETAIL GB
(FRONT VIEW)

PANEL-MONITOR,
PCS 50 AMP
174384-06-000

MODULE-AUTO
GENERATOR START
158425-01-000 32W 1

VIEW GA

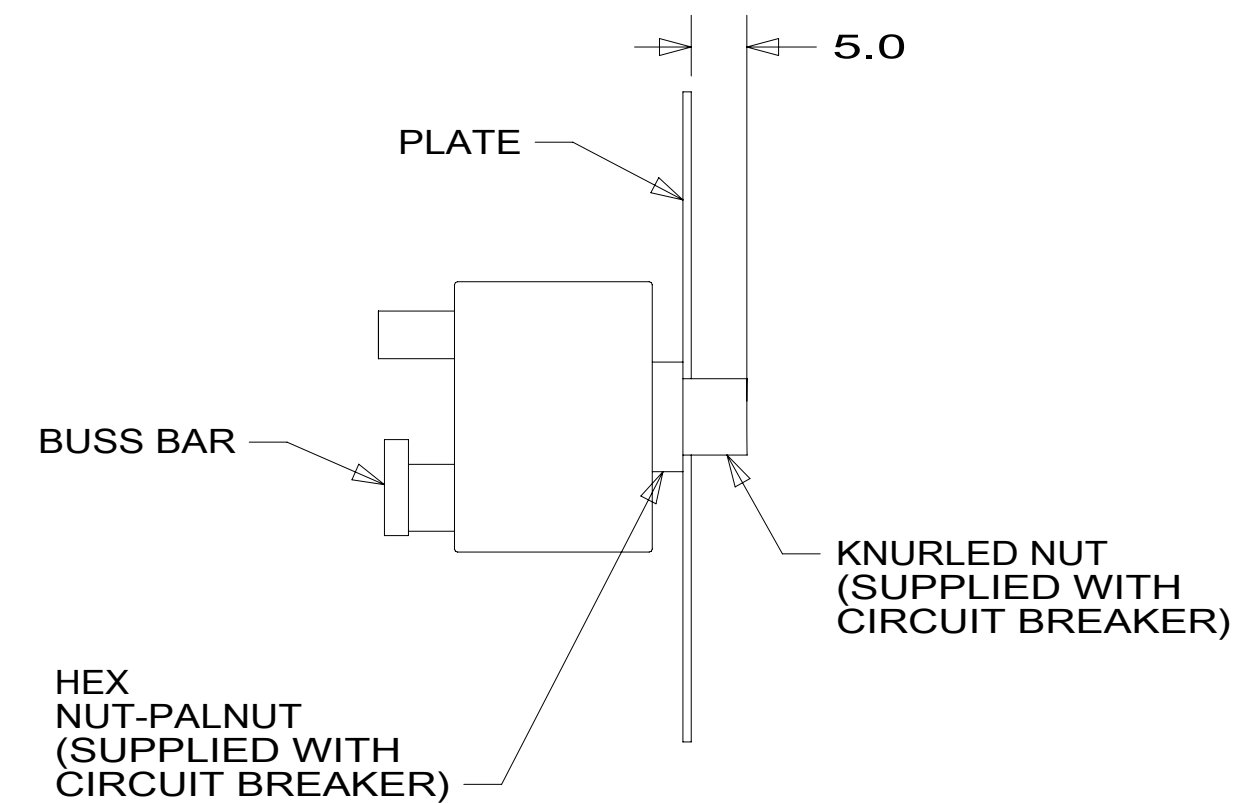

VIEW GC-GC

2 CONFIRM "BAT TYPE" SET TO "FLOODED",
SET "LBCO" TO "11 VDC".
SET "BAT AHRS" TO "400 AH" WITH
SEE OPERATORS MANUAL FOR SETUP PROCEDURE.

1 SEE 'GEN TYPE' TO 'GAS/LP'
SET 'SAFE TYPE' TO 'IGNITION'
SET 'SP SENSE' TO 'AFTER'
SEE OPERATOR'S MANUAL FOR SETUP PROCEDURE.

NOTES:

- 45B LOFT BED
- 79W REFRIGERATOR-4 DOOR
- 32W GENERATOR-START,AUTO SYSTEM
- 265 CODES/STANDARDS-CSA/CMVSS
- 1B1 CODES/STANDARDS USA

FOR ELECTRICAL
TORQUE
SPECIFICATIONS
SEE DWG NO.
128783-01-000

FOR ELECTRICAL
CALLOUTS
SEE DWG NO.
121339-01-000

DESCRIPTION: WIRING INSTL-BODY, 12V	
SHEET: 7 OF 8	ITEM/PART NO: 000128362 / 32496201000
REV 15-Jan-2018	

8 7 6 5 4 3 2 1

D

D

C

C

B

B

A

A

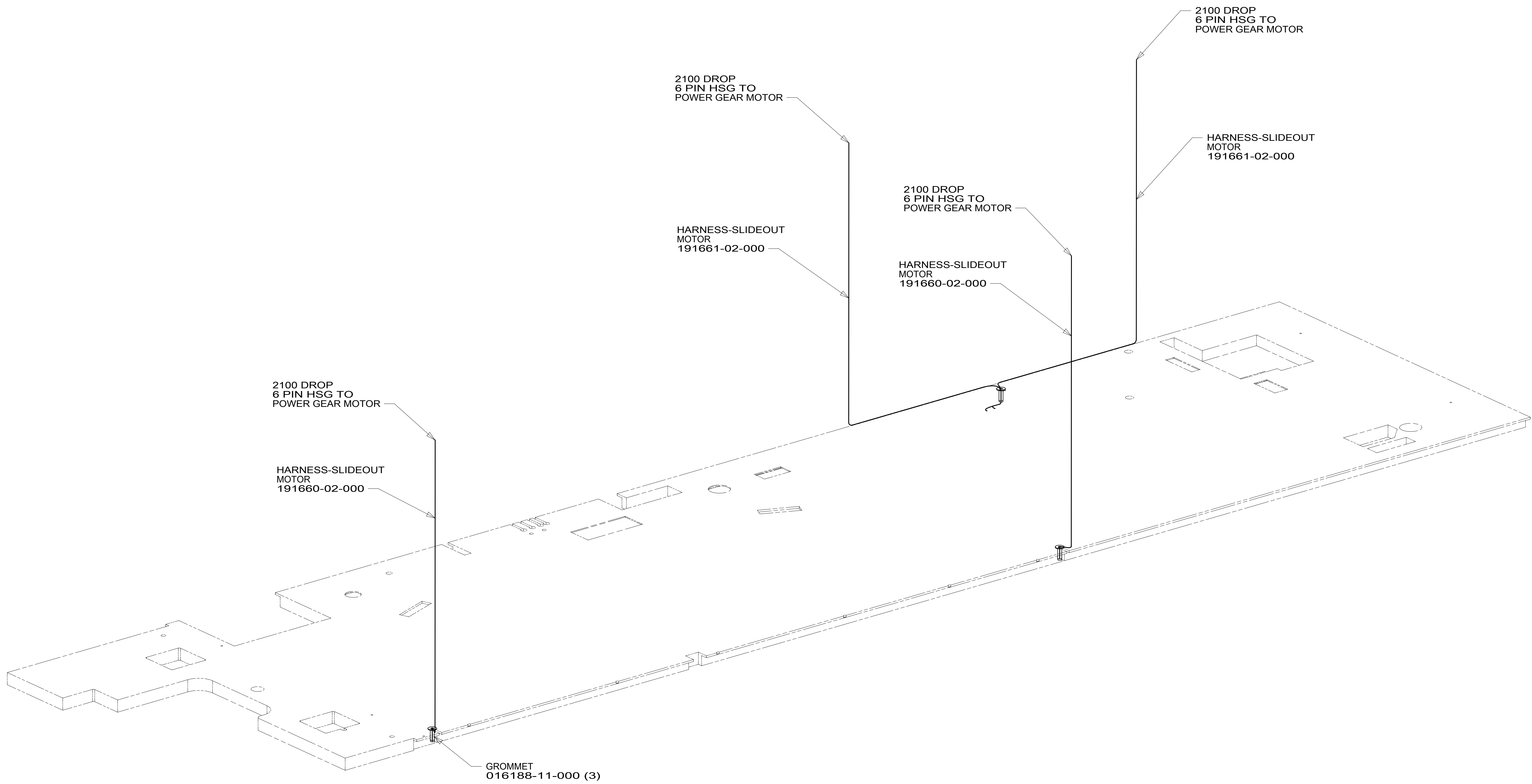

265 CODES/STANDARDS-CSA/CMVSS

1B1 CODES/STANDARDS USA

1B1 265

FOR ELECTRICAL
TORQUE
SPECIFICATIONS
SEE DWG NO.
128783-01-000

FOR
ELECTRICAL
CALLOUTS
SEE DWG NO.
121339-01-000

DESCRIPTION:
WIRING INSTL-BODY, 12V

SHEET: 8 OF 8	ITEM/PART NO: 000128362 / 32496201000	REV
-------------------------	---	-----