

- 10. FASTEN PLATFORM TO FLOOR AFTER SIDEWALL IS SET AND HEATER IS ATTACHED TO WALL.
- 9. ALL CRIMP FITTINGS TO 3/4" PEX TUBING REQUIRE 3/4" CLAMP 000156247 / 326668-01-000.
- 8. ALL CRIMP FITTINGS TO 1/2" PEX TUBING REQUIRE 1/2" CLAMP 000156249 / 326670-01-000.
- 7. ALL CRIMP FITTINGS TO 5/8" FLEX TUBING REQUIRE 5/8" CLAMP 000156248 / 326669-01-000.
- 6. LABEL HOT AND COLD SUPPLY TUBES AND TAPE FITTING TO TUBE BEFORE CABINET SET TO PREVENT MOVEMENT.
- 5. ADD PIPE WRAP (LADDER SCRAP 110157-02-000) INSULATION.
- 4. ADD TEFLON TAPE 010405-02-000.
- 3. ALL TUBING TO BE SECURED AT 1200 INTERVALS MAXIMUM WITH CLAMP 010495-01-000 AND SCREW 000G67-10-12U OR EQUIVALENT.
- 2. TUBING TO BE INSTALLED WITH SUFFICIENT SLOPE TO PROVIDE DRAINAGE TO NEAREST VALVE.
- 1. PLASTIC FITTINGS TO BE SEALED WITH SEALANT 084456-01-000.

NOTES:

X-X
 FOR WATER CALLOUTS SEE DWG NO. 000209446 / 303369-01-000

COPYRIGHT 2018 WINNEBAGO INDUSTRIES, INC.

DSNR:		ALL DIMENSIONS ARE IN MILLIMETERS	
DIFTR:			
UNSPECIFIED TOLERANCES:	MATERIAL:		
WHOLE DIM (X) :	3		
ONE-PLACE (X.X) :	1.5		
TWO-PLACE (X.XX) :	0.50		
ANGLE :	1°		
REFER TO ES0018 FOR FASTENER TIGHTENING GUIDELINES	WEIGHT: (LBS)	FIRST USED: (REF)	
		18 E27PE	
DESCRIPTION: WATER SYSTEM INSTL			
SHEET:	ITEM/PART NO.:	REV	
1 OF 3	000127399 / 32473201000		
REF:		1 31-Jan-2018	

8 7 6 5 4 3 2 1

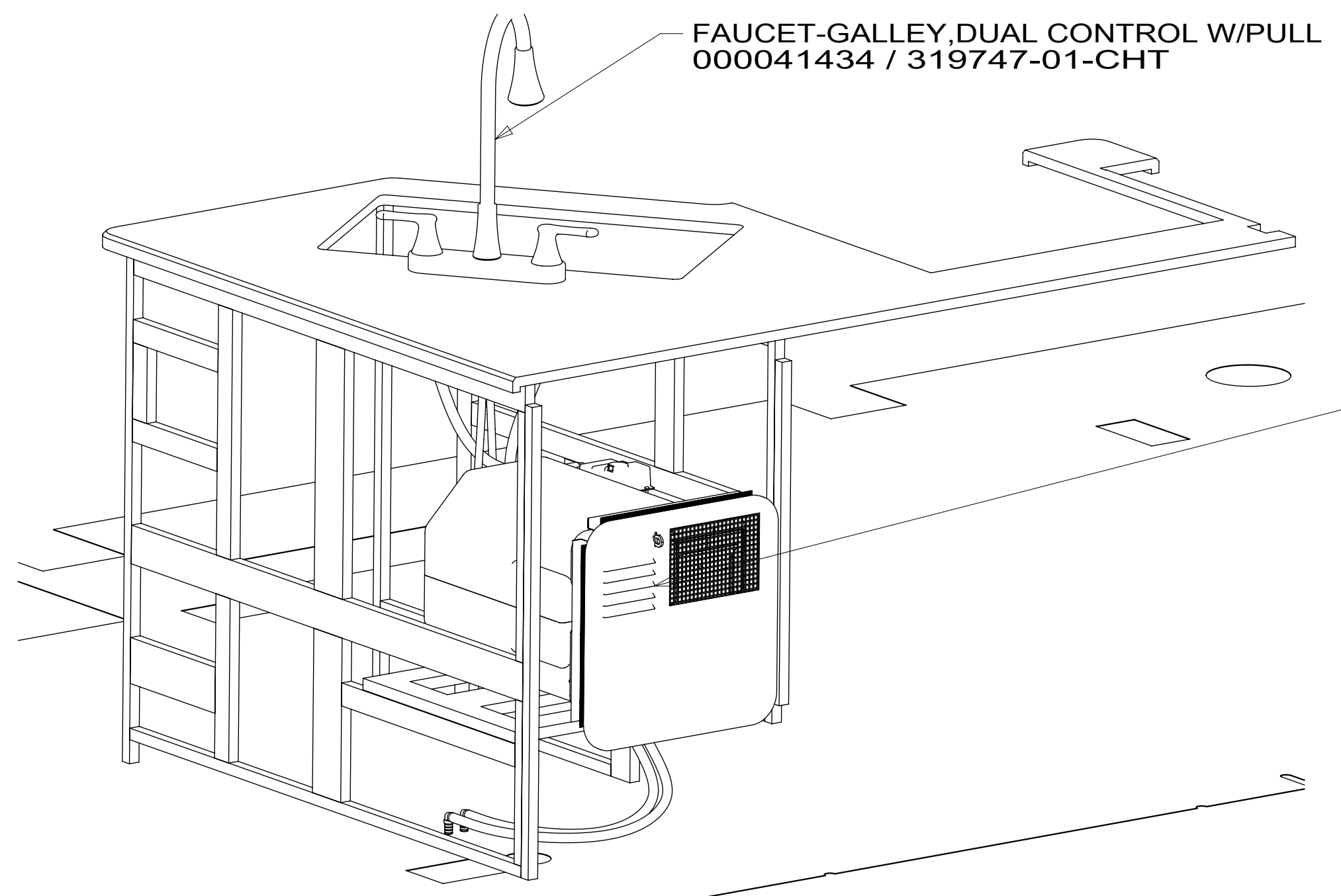

VIEW BB

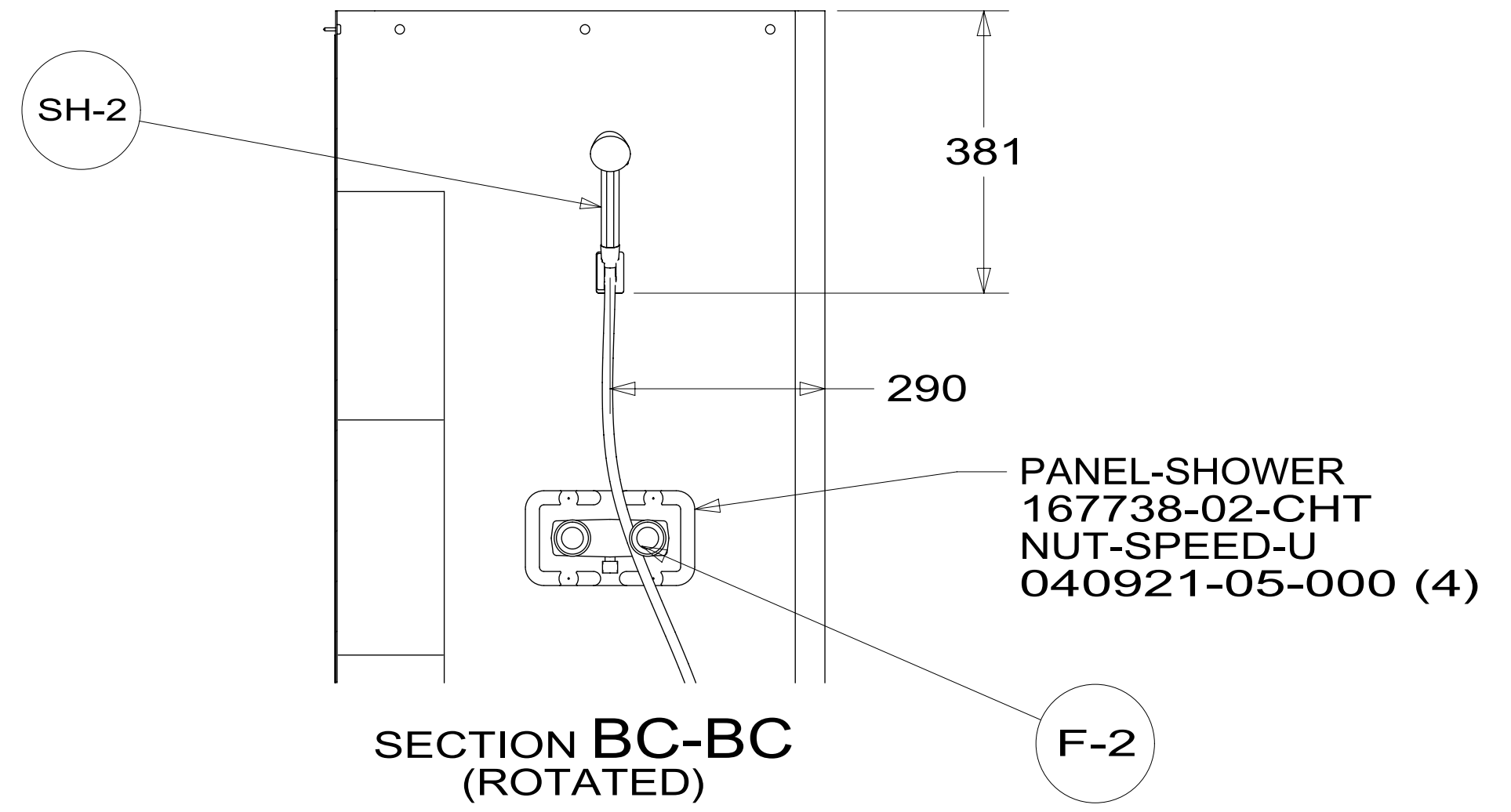

SECTION BC-BC (ROTATED)

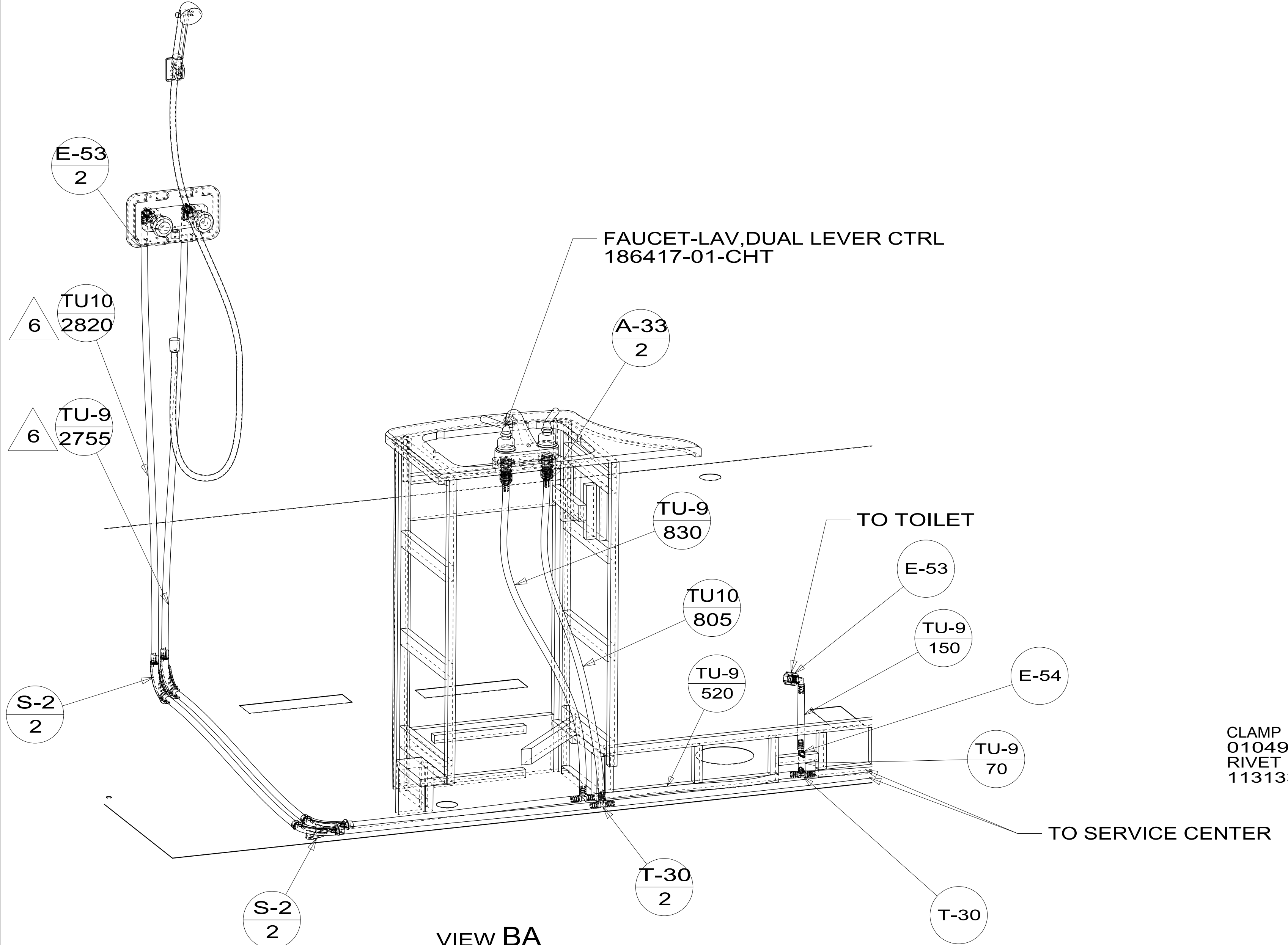

VIEW BA

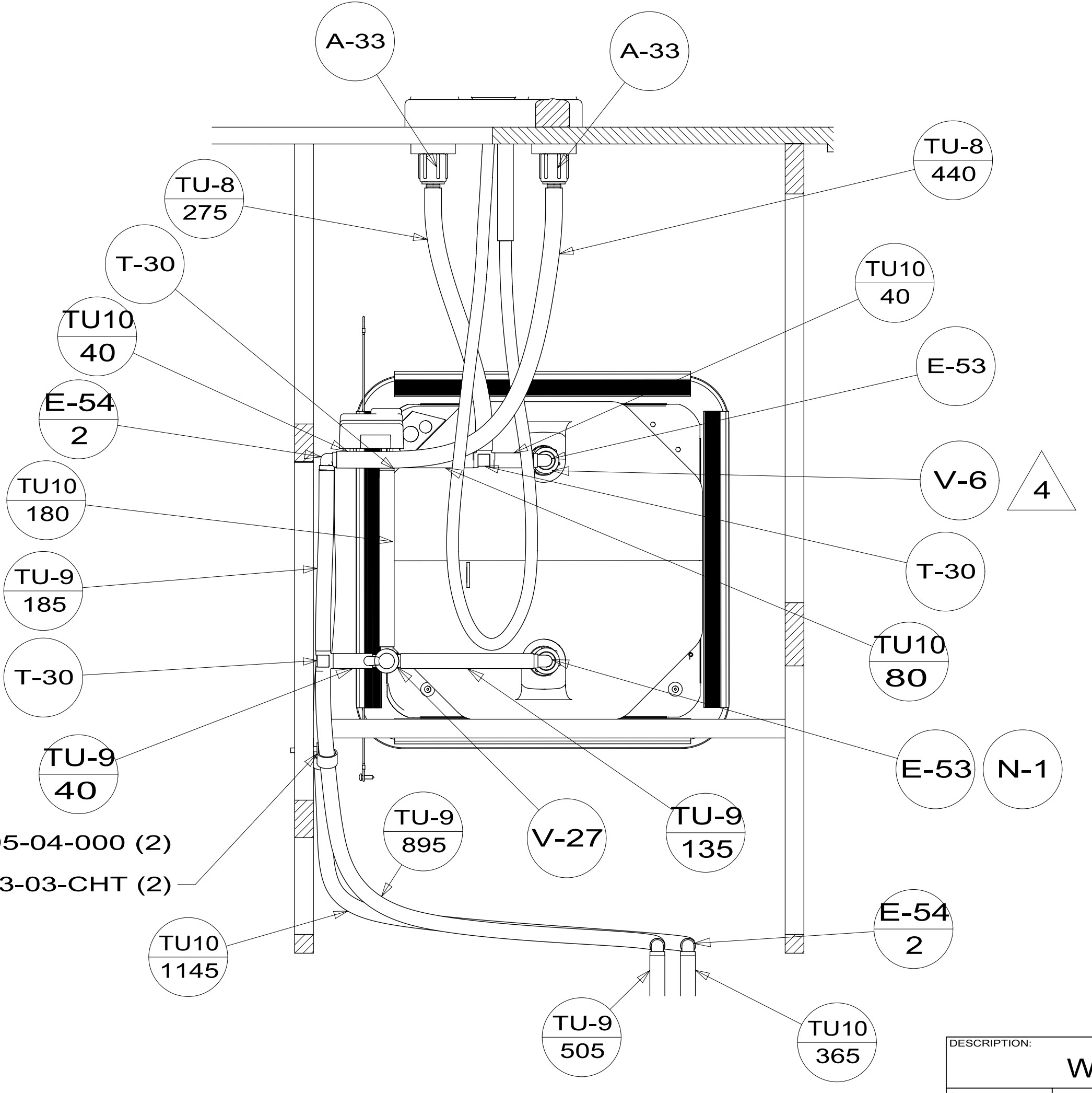

SECTION BD-BD

DESCRIPTION: WATER SYSTEM INSTL		
SHEET: 2 OF 3	ITEM/PART NO: 000127399 / 32473201000	REV
		1 31-Jan-2018

8 7 6 5 4 3 2 1

