

8

7

6

5



4

3

2

1

D

D

C

C



B

B

A

A

8

7

6

5



4

3

2

1

CABLE ASM-CHASSIS BATTERY (RED)	192678-02-000	
CABLE ASM-COACH BATTERY (YEL)	141415-52-064	
CABLE ASM-COACH BATTERY GND (BLK)	133566-12-029	
CABLE ASM-GENERATOR (GRN)	141415-42-055	
CABLE ASM-GENERATOR GND (BLK)	133566-12-020	
CABLE ASM-JUMPER,POS (YEL)	141415-59-018	
CABLE ASM-JUMPER,NEG (BLK)	133566-12-020	
CABLE ASM-INVERTER FUSE (ORG)	141415-61-004	401
CABLE ASM-INVERTER (ORG)	141415-62-043	401
CABLE ASM-INVERTER GND (BLK)	133566-12-043	401
CABLE ASM-INVERTER CASE GND (BLK)	136145-05-021	401

401

401

401

401

401 INVERTER-DC/AC, 1000 WATT

265 CODES/STANDARDS-CSA/CMVSS

1B1 CODES/STANDARDS USA

1B1 265



COPYRIGHT 2016 WINNEBAGO INDUSTRIES, INC.

DSNR:		ALL DIMENSIONS ARE IN MILLIMETERS		
DFFR:		MATERIAL:		
UNSPECIFIED TOLERANCES:				
WHOLE DIM (X)	: 3			
ONE-PLACE (X.X)	: 1.5			
TWO-PLACE (X.XX)	: 0.50			
ANGLE	: 1°			

REFER TO ES0018 FOR FASTENER TIGHTENING GUIDELINES

WEIGHT: (LBS) FIRST USED: 18 170X

FOR ELECTRICAL TORQUE SPECIFICATIONS SEE DWG NO. 128783-01-000

FOR ELECTRICAL CALLOUTS SEE DWG NO. 121339-01-000

DESCRIPTION: BATTERY INSTL

SHEET: 1 OF 4 ITEM/PART NO: 000126801 / 32452601000 REV

REF: 1 20-Sep-2018

8 7 6 5 4 3 2 1

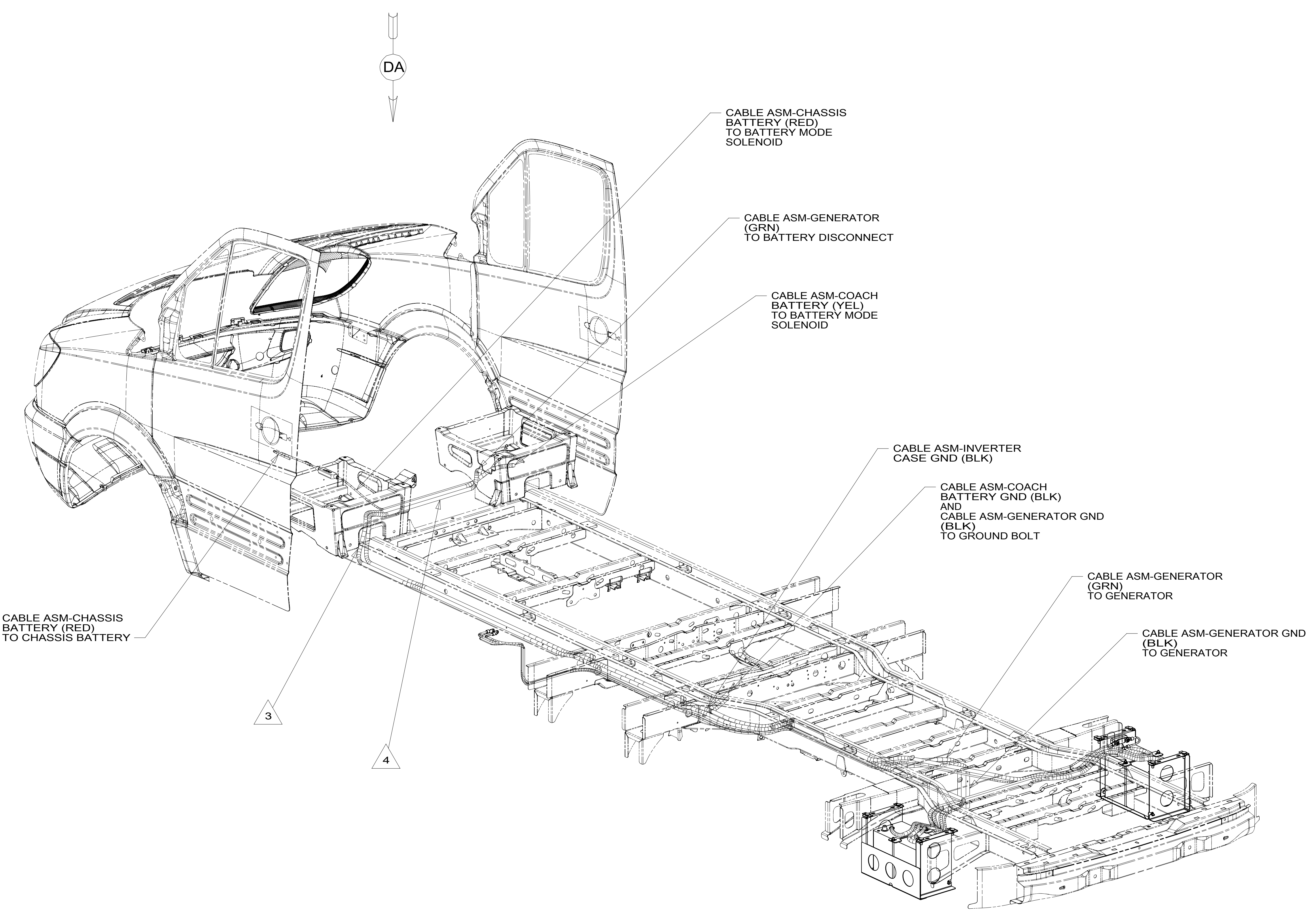

CABLE ASM-CHASSIS BATTERY (RED) TO CHASSIS BATTERY

CABLE ASM-CHASSIS BATTERY (RED) TO BATTERY MODE SOLENOID

CABLE ASM-GENERATOR (GRN) TO BATTERY DISCONNECT

CABLE ASM-COACH BATTERY (YEL) TO BATTERY MODE SOLENOID

CABLE ASM-INVERTER CASE GND (BLK)

CABLE ASM-COACH BATTERY GND (BLK) AND CABLE ASM-GENERATOR GND (BLK) TO GROUND BOLT

CABLE ASM-GENERATOR (GRN) TO GENERATOR

CABLE ASM-GENERATOR GND (BLK) TO GENERATOR

3

4

4 CABLES ROUTED THROUGH TROUGH BETWEEN CAB SEATS IN THIS AREA.

3 ROUTE CABLES THROUGH GROMMET UNDER DRIVERS SEAT.

2. SEE WIRING INSTL-CHASSIS FOR ADDITIONAL INFORMATION.

1. AT MINIMUM ALL WIRES TO BE SUPPORTED AND SECURED PER CODE REQUIREMENTS. USE CLAMP 10495 OR 10497 OR WIRE TIE 8343 OR 108046 AND SCREW G67-XX-XXX OR G56-XX-XXX AS APPROPRIATE FOR INSTALLATION.

NOTES:

265 CODES/STANDARDS-CSA/CMVSS

1B1 CODES/STANDARDS USA

1B1 265

FOR ELECTRICAL TORQUE SPECIFICATIONS SEE DWG NO. 128783-01-000

FOR ELECTRICAL CALLOUTS SEE DWG NO. 121339-01-000

DESCRIPTION:		
<b>BATTERY INSTL</b>		
SHEET:	ITEM/PART NO.:	REV:
2 OF 4	000126801 / 32452601000	

8 7 6 5 4 3 2 1 20-Sep-2018

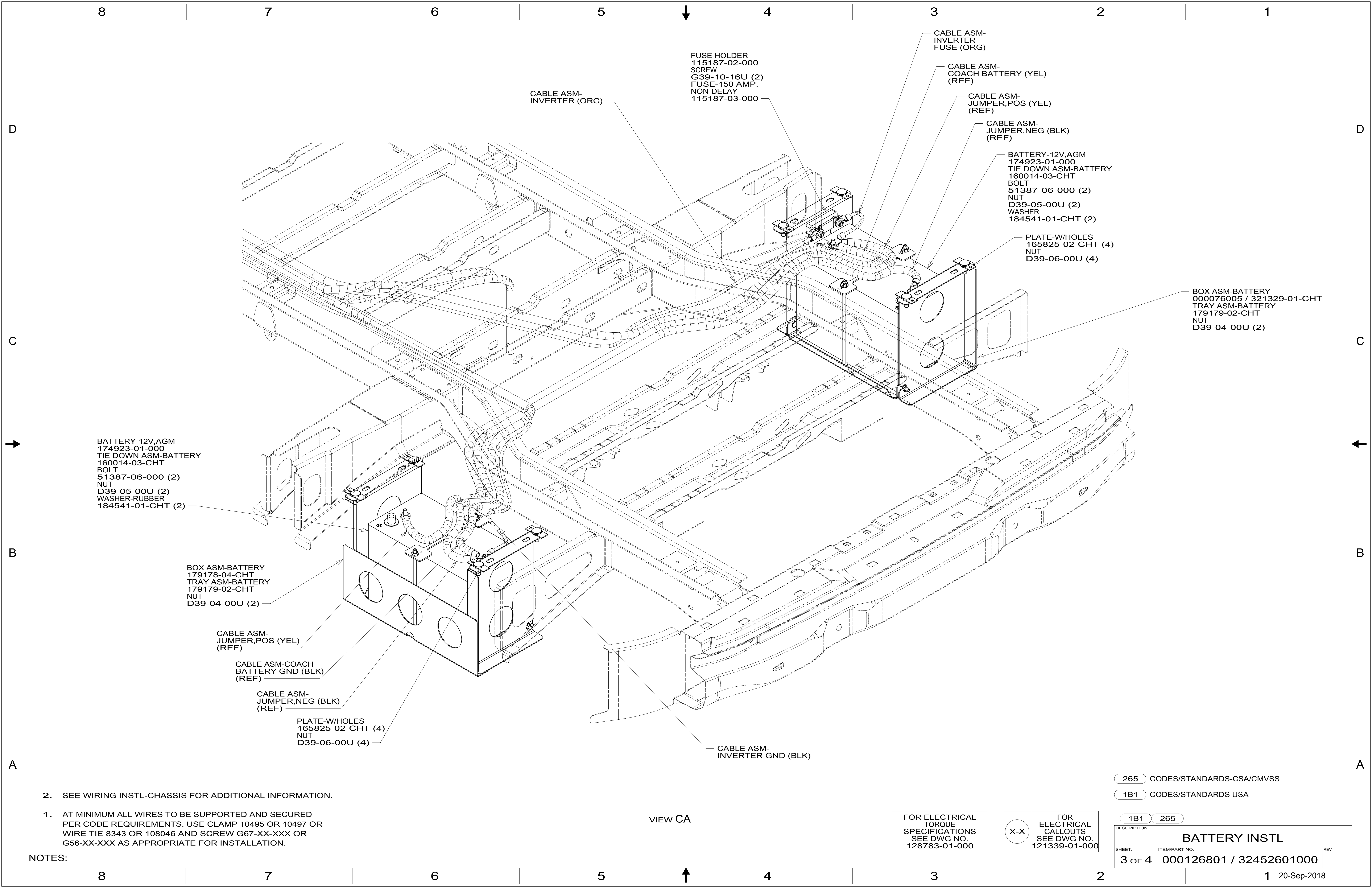

BATTERY-12V,AGM  
174923-01-000  
TIE DOWN ASM-BATTERY  
160014-03-CHT  
BOLT  
51387-06-000 (2)  
NUT  
D39-05-00U (2)  
WASHER-RUBBER  
184541-01-CHT (2)

BOX ASM-BATTERY  
179178-04-CHT  
TRAY ASM-BATTERY  
179179-02-CHT  
NUT  
D39-04-00U (2)

CABLE ASM-  
JUMPER,POS (YEL)  
(REF)

CABLE ASM-COACH  
BATTERY GND (BLK)  
(REF)

CABLE ASM-  
JUMPER,NEG (BLK)  
(REF)

PLATE-W/HOLES  
165825-02-CHT (4)  
NUT  
D39-06-00U (4)

CABLE ASM-  
INVERTER (ORG)

FUSE HOLDER  
115187-02-000  
SCREW  
G39-10-16U (2)  
FUSE-150 AMP,  
NON-DELAY  
115187-03-000

CABLE ASM-  
INVERTER  
FUSE (ORG)

CABLE ASM-  
COACH BATTERY (YEL)  
(REF)

CABLE ASM-  
JUMPER,POS (YEL)  
(REF)

CABLE ASM-  
JUMPER,NEG (BLK)  
(REF)

BATTERY-12V,AGM  
174923-01-000  
TIE DOWN ASM-BATTERY  
160014-03-CHT  
BOLT  
51387-06-000 (2)  
NUT  
D39-05-00U (2)  
WASHER  
184541-01-CHT (2)

PLATE-W/HOLES  
165825-02-CHT (4)  
NUT  
D39-06-00U (4)

BOX ASM-BATTERY  
000076005 / 321329-01-CHT  
TRAY ASM-BATTERY  
179179-02-CHT  
NUT  
D39-04-00U (2)

CABLE ASM-  
INVERTER GND (BLK)

2. SEE WIRING INSTL-CHASSIS FOR ADDITIONAL INFORMATION.

1. AT MINIMUM ALL WIRES TO BE SUPPORTED AND SECURED PER CODE REQUIREMENTS. USE CLAMP 10495 OR 10497 OR WIRE TIE 8343 OR 108046 AND SCREW G67-XX-XXX OR G56-XX-XXX AS APPROPRIATE FOR INSTALLATION.

NOTES:

VIEW CA

FOR ELECTRICAL  
TORQUE  
SPECIFICATIONS  
SEE DWG NO.  
128783-01-000

FOR  
ELECTRICAL  
CALLOUTS  
SEE DWG NO.  
121339-01-000

265 CODES/STANDARDS-CSA/CMVSS  
1B1 CODES/STANDARDS USA

DESCRIPTION:		1B1	265
<b>BATTERY INSTL</b>			
SHEET:	ITEM/PART NO.:	REV	
3 OF 4	000126801 / 32452601000		



NUT  
OMD29K-08-000

CABLE ASM-  
CHASSIS BATTERY

2. SEE WIRING INSTL-CHASSIS FOR ADDITIONAL INFORMATION.

1. AT MINIMUM ALL WIRES TO BE SUPPORTED AND SECURED PER CODE REQUIREMENTS. USE CLAMP 10495 OR 10497 OR WIRE TIE 8343 OR 108046 AND SCREW G67-XX-XXX OR G56-XX-XXX AS APPROPRIATE FOR INSTALLATION.

NOTES:

VIEW DA

FOR ELECTRICAL  
TORQUE  
SPECIFICATIONS  
SEE DWG NO.  
128783-01-000

FOR  
ELECTRICAL  
CALLOUTS  
SEE DWG NO.  
121339-01-000

265 CODES/STANDARDS-CSA/CMVSS  
1B1 CODES/STANDARDS USA

1B1 265	
DESCRIPTION: <b>BATTERY INSTL</b>	
SHEET: 4 OF 4	ITEM/PART NO: 000126801 / 32452601000