

- 6 WITH 1D&RUTE YELLOW COAX TO SLIDEOUT WITH WIRE ASM-COACH.
  - 5 WIRING IS PART OF WIRE ASM-CHASSIS.
  - 4 WIRE PASSES THROUGH FLOOR IN THIS AREA.
  - 3 PLACE CROSS LOCATOR ON SENSORS OVER DIMPLES ON TANK.
2. ROUTE TANK SENSOR WIRES SO THEY DO NOT PASS OVER SENSORS. USE WIRE TIE MOUNT 155366-01-000 AND WIRE TIE 8343-01-000 AS NEEDED. TANK SURFACE MUST BE CLEANED USING ISOPROPYL ALCOHOL AND PRIMED WITH PRIMER 94.
  1. AT MINIMUM ALL WIRES TO BE SUPPORTED AND SECURED PER CODE REQUIREMENTS. USE CLAMP 10495 OR 10497 OR WIRE TIE 8343 OR 108046 AND SCREW G67-XX-XXX OR G56-XX-XXX AS APPROPRIATE FOR INSTALLATION.

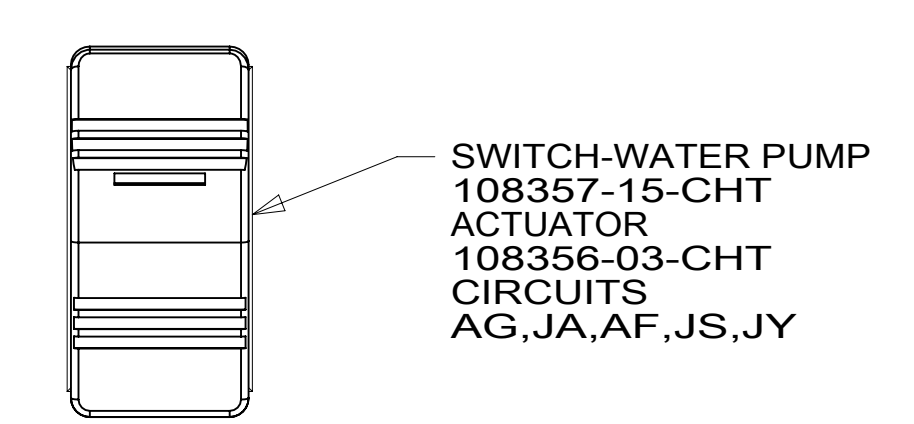
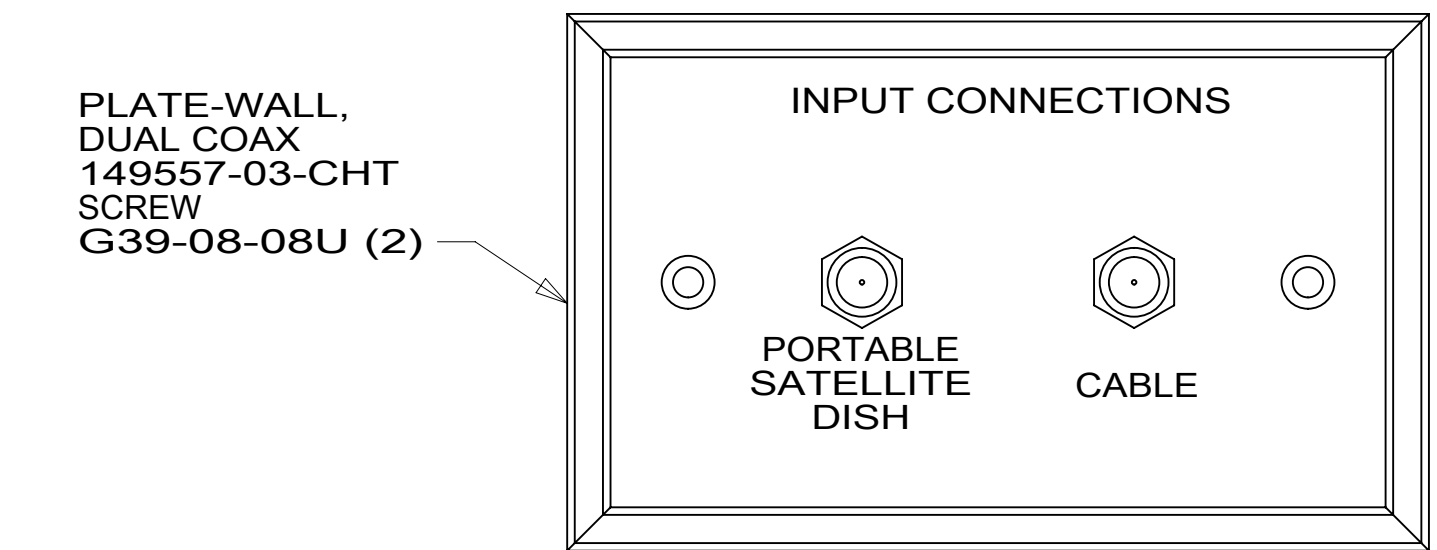

FOR ELECTRICAL TORQUE SPECIFICATIONS SEE DWG NO. 128783-01-000

FOR ELECTRICAL CALLOUTS SEE DWG NO. 121339-01-000

- 299 ENTERTAINMENT CENTER EXT.W/O
- 1D3 ENTERTAIN CENTR/EXT TV-DVD
- 265 CODES/STANDARDS-CSA/CMVSS
- 1B1 CODES/STANDARDS USA

**WINNEBAGO**  
COPYRIGHT 2016 WINNEBAGO INDUSTRIES, INC.

|  |                                       |                     |
|--|---------------------------------------|---------------------|
| DSNR:  | ALL DIMENSIONS ARE IN MILLIMETERS     |                     |
| DFFR:  |                                       |                     |
| UNSPECIFIED TOLERANCES:                            | MATERIAL:                             |                     |
| WHOLE DIM (X) : 3                                  |                                       |                     |
| ONE-PLACE (X.X) : 1.5                              |                                       |                     |
| TWO-PLACE (X.XX) : 0.50                            |                                       |                     |
| ANGLE : 1°   |                                       |                     |
| REFER TO ES0018 FOR FASTENER TIGHTENING GUIDELINES | WEIGHT: (LBS)                         | FIRST USED: 18 E27N |
| DESCRIPTION: <b>WIRING INSTL-BODY, 12V</b>         |                                       |                     |
| SHEET: 1 OF 7                                      | ITEM/PART NO: 000124486 / 32393601000 | REV                 |

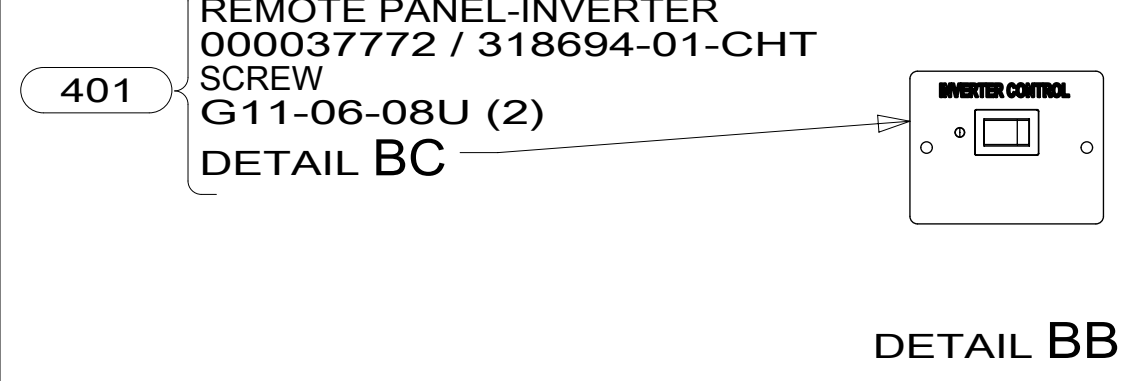
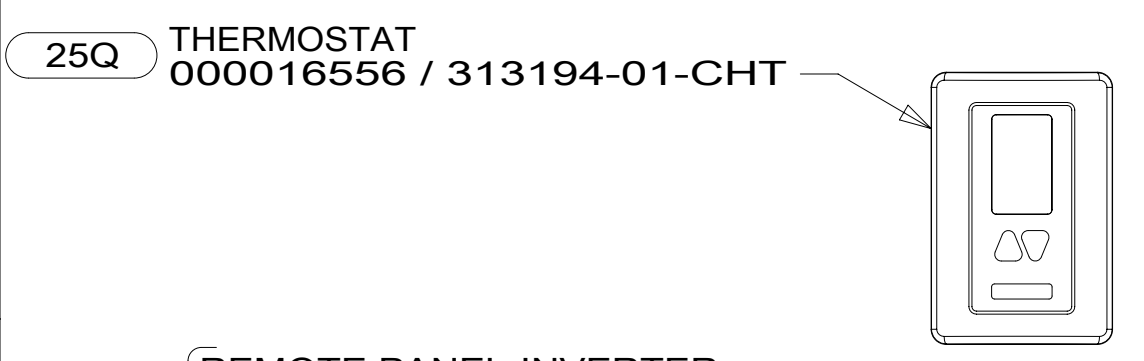
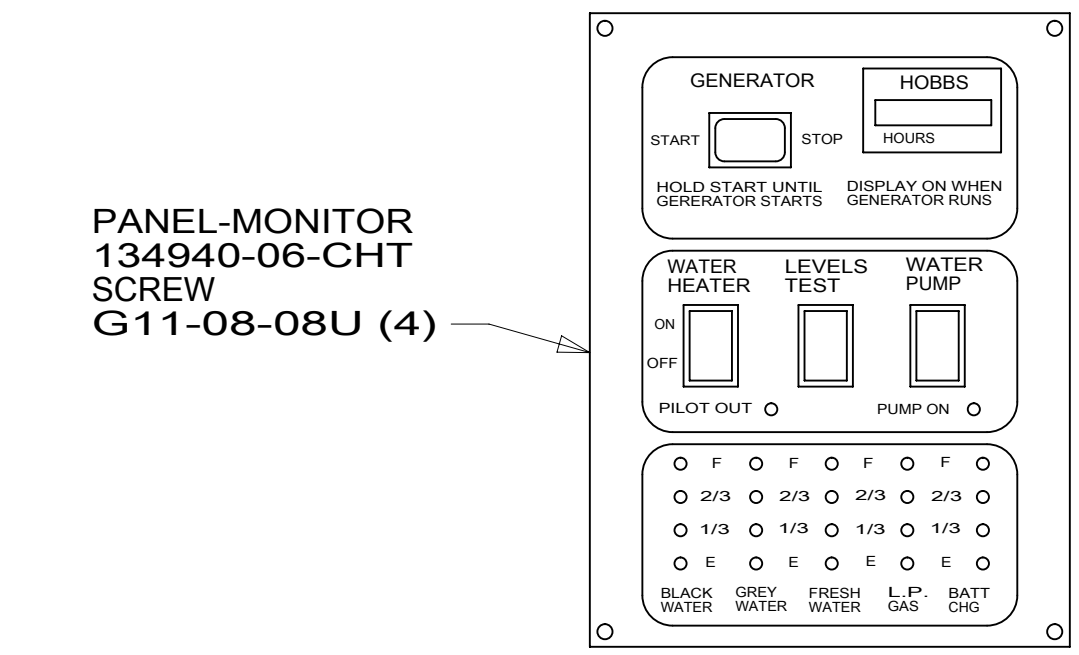
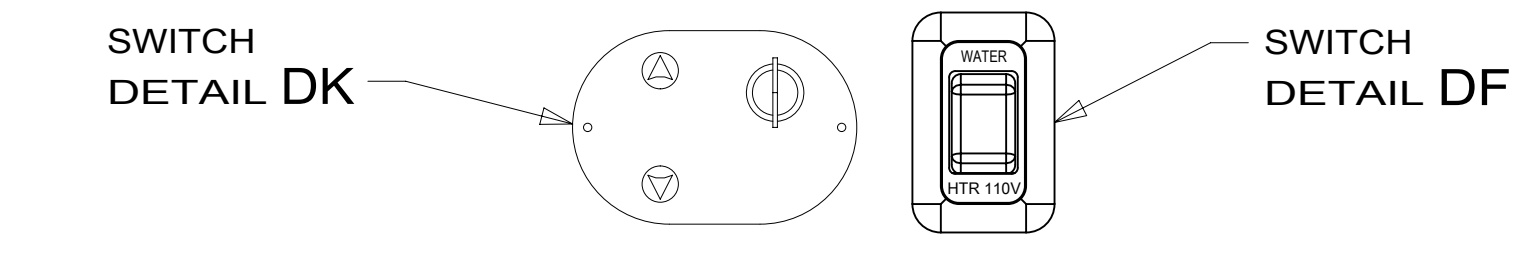
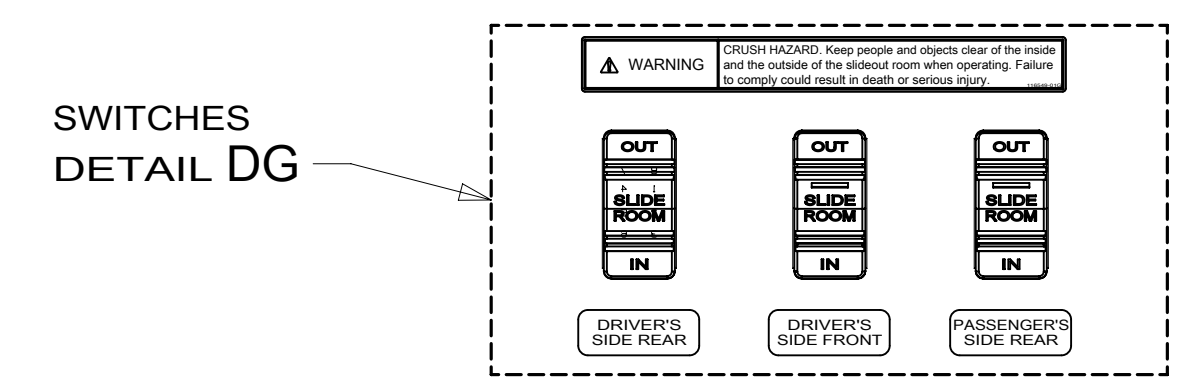
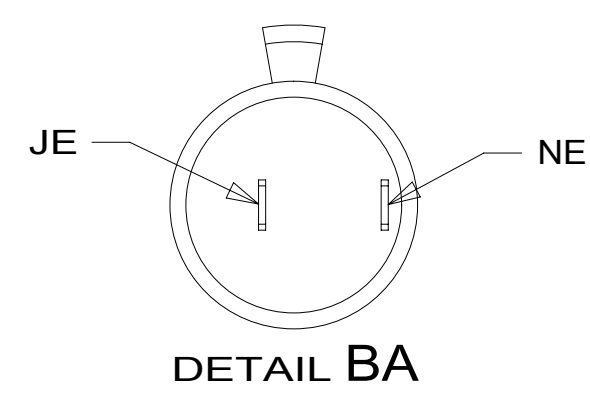

2-PIN HSG TO WIRE ASM-ROOF

WIRE ASM-OVHD 192894-01-000

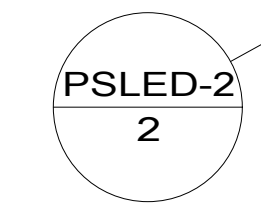

SWITCH DETAIL DL

WIRE ASM-OVHD 133572-01-015  
TO WIRE ASM-ROOF DETAIL FA

TO WIRE ASM-SLIDEOUT

MAIN TV CONNECTORS FROM ROOF

RECEPTACLE-12V 132958-01-000 DETAIL BA

LIGHT-CEILING, DOUBLE UL/CSA 000028895 / 316335-01-CHT BULB 117805-02-000 (2) CONNECTOR 58028-01-000 (2) SCREW G11-06-10U (2)

SWITCH DETAIL DJ

SWITCH DETAIL DB

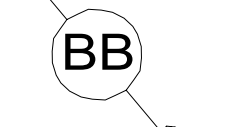

SWITCH DETAIL DA

LOAD CENTER (REF)

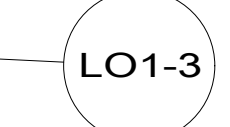

PANEL-SERVICE 132862-08-CHT SCREW G39-10-12U (4)

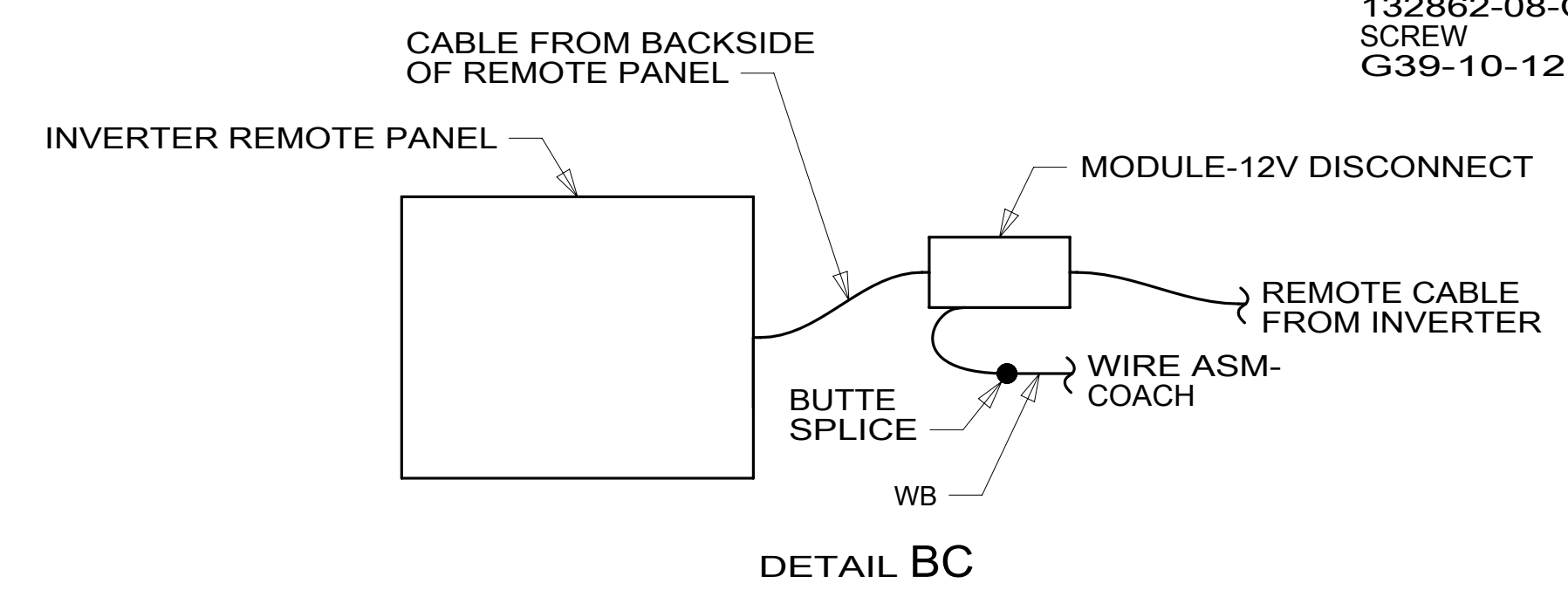

FOR ELECTRICAL TORQUE SPECIFICATIONS SEE DWG NO. 128783-01-000

FOR ELECTRICAL CALLOUTS SEE DWG NO. 121339-01-000

- 401 INVERTER-DC/AC, 1000 WATT
- 25Q A/C ROOF AIR (1) 14,800 BTU
- 265 CODES/STANDARDS-CSA/CMVSS
- 1B1 CODES/STANDARDS USA

|                               |                         |         |  |
|-------------------------------|-------------------------|---------|--|
| DESCRIPTION:                  |                         | 1B1 265 |  |
| <b>WIRING INSTL-BODY, 12V</b> |                         |         |  |
| SHEET:                        | ITEM/PART NO.:          | REV:    |  |
| 2 OF 7                        | 000124486 / 32393601000 |         |  |

- NOTES:
- AT MINIMUM ALL WIRES TO BE SUPPORTED AND SECURED PER CODE REQUIREMENTS. USE CLAMP 10495 OR 10497 OR WIRE TIE 8343 OR 108046 AND SCREW G67-XX-XXX OR G56-XX-XXX AS APPROPRIATE FOR INSTALLATION.



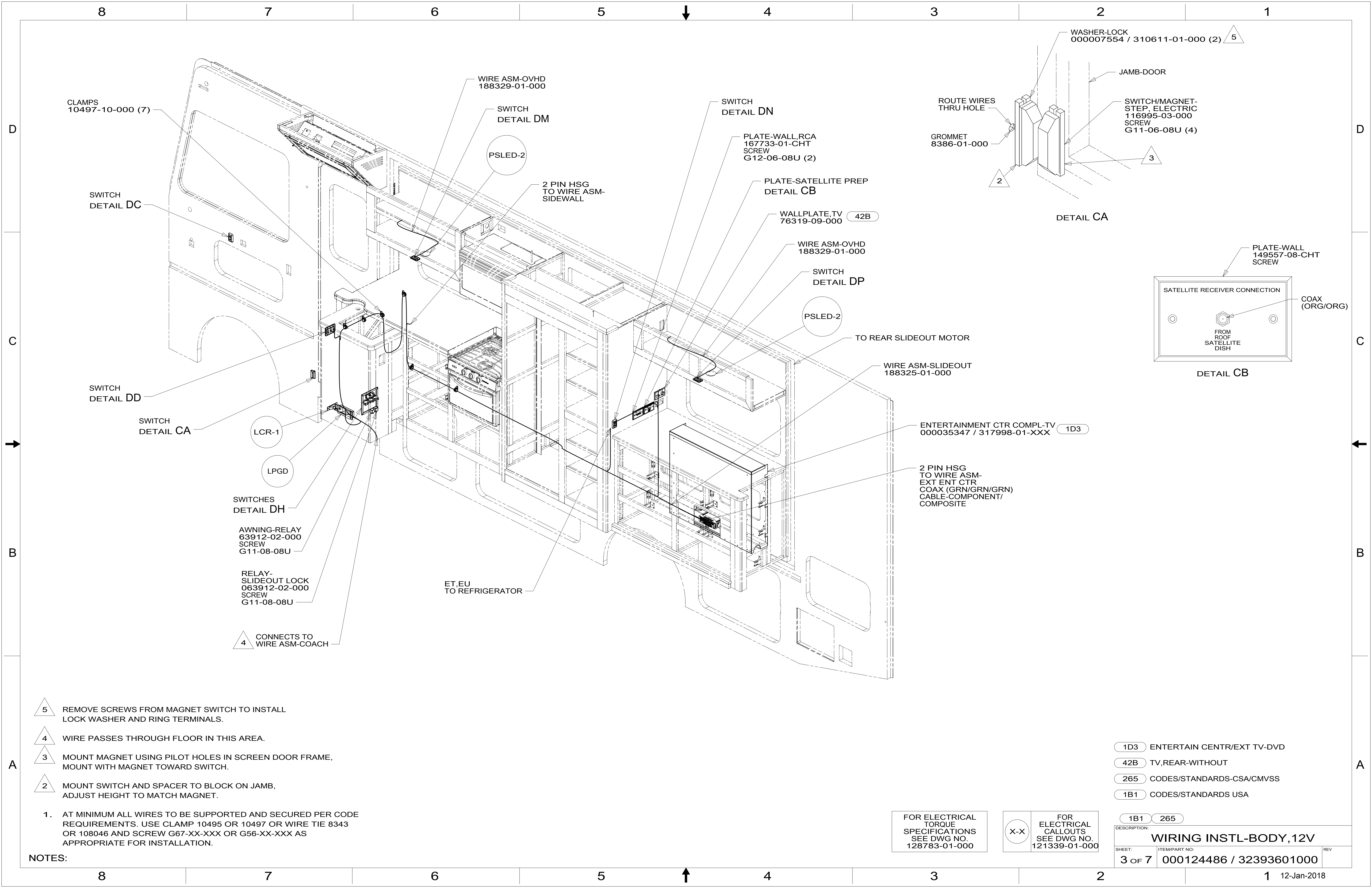

- 5 REMOVE SCREWS FROM MAGNET SWITCH TO INSTALL LOCK WASHER AND RING TERMINALS.
- 4 WIRE PASSES THROUGH FLOOR IN THIS AREA.
- 3 MOUNT MAGNET USING PILOT HOLES IN SCREEN DOOR FRAME, MOUNT WITH MAGNET TOWARD SWITCH.
- 2 MOUNT SWITCH AND SPACER TO BLOCK ON JAMB, ADJUST HEIGHT TO MATCH MAGNET.

1. AT MINIMUM ALL WIRES TO BE SUPPORTED AND SECURED PER CODE REQUIREMENTS. USE CLAMP 10495 OR 10497 OR WIRE TIE 8343 OR 108046 AND SCREW G67-XX-XXX OR G56-XX-XXX AS APPROPRIATE FOR INSTALLATION.

NOTES:

- 1D3 ENTERTAIN CTR/EXT TV-DVD
- 42B TV,REAR-WITHOUT
- 265 CODES/STANDARDS-CSA/CMVSS
- 1B1 CODES/STANDARDS USA

FOR ELECTRICAL TORQUE SPECIFICATIONS SEE DWG NO. 128783-01-000

FOR ELECTRICAL CALLOUTS SEE DWG NO. 121339-01-000

|                               |                         |         |  |
|-------------------------------|-------------------------|---------|--|
| DESCRIPTION:                  |                         | 1B1 265 |  |
| <b>WIRING INSTL-BODY, 12V</b> |                         |         |  |
| SHEET:                        | ITEM/PART NO.:          | REV     |  |
| 3 OF 7                        | 000124486 / 32393601000 |         |  |

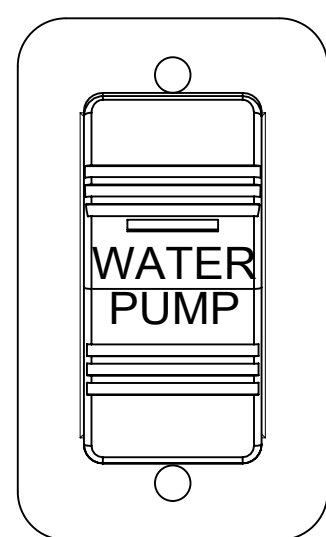

SWITCH-PUMP  
108357-15-000  
ACTUATOR  
108356-23-CHT  
PLATE  
98351-07-CHT  
SCREW  
G11-06-10U (2)

DETAIL DA

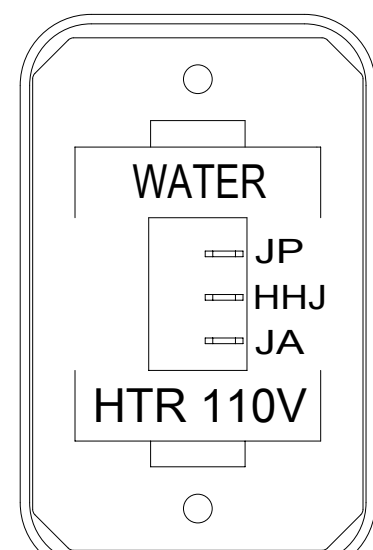

SWITCH-ROCKER  
135740-06-CHT  
SWITCH-BASE  
135741-01-CHT  
SWITCH-BEZEL  
135742-35-CHT  
SCREW  
G11-08-08U (2)

DETAIL DF

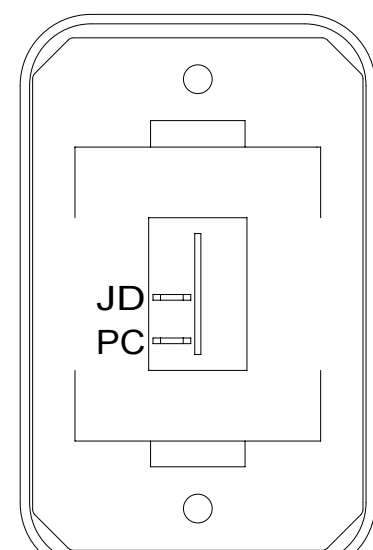

SWITCH-ROCKER  
135740-01-CHT  
SWITCH-BASE  
135741-01-CHT  
SWITCH-BEZEL  
135742-01-CHT  
SCREW  
G11-08-08U (2)

DETAIL DN

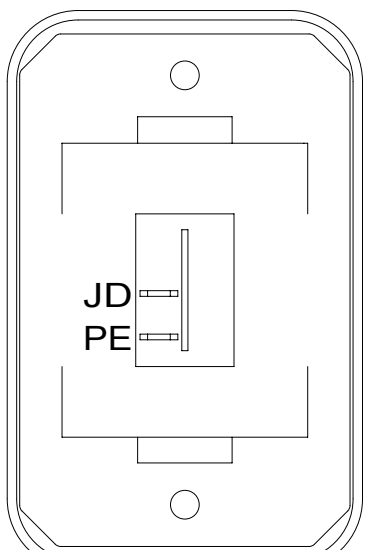

SWITCH-ROCKER  
135740-01-CHT  
SWITCH-BASE  
135741-01-CHT  
SWITCH-BEZEL  
135742-01-CHT  
SCREW  
G11-08-08U (2)

DETAIL DB

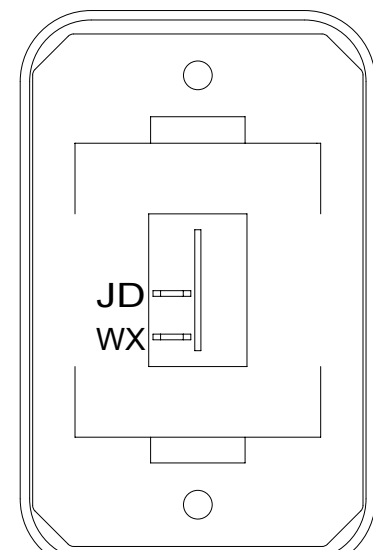

SWITCH-ROCKER  
135740-01-CHT  
SWITCH-BASE  
135741-01-CHT  
SWITCH-BEZEL  
135742-01-CHT  
SCREW  
G11-08-08U (2)

DETAIL DJ

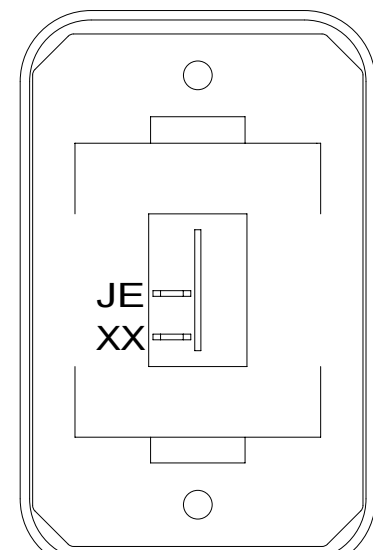

SWITCH-ROCKER  
135740-01-CHT  
SWITCH-BASE  
135741-01-CHT  
SWITCH-BEZEL  
135742-01-CHT  
SCREW  
G11-08-08U (2)

DETAIL DP

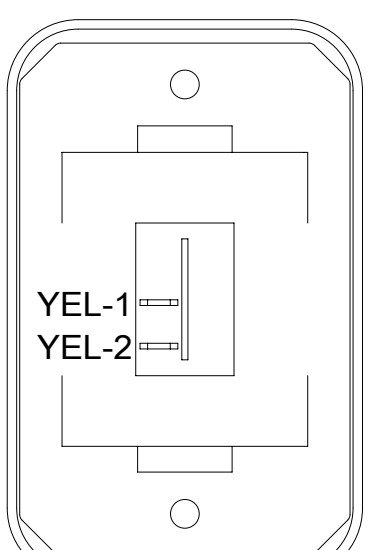

SWITCH-ROCKER  
135740-01-CHT  
SWITCH-BASE  
135741-01-CHT  
SWITCH-BEZEL  
135742-01-CHT  
SCREW  
G11-08-08U (2)

DETAIL DC

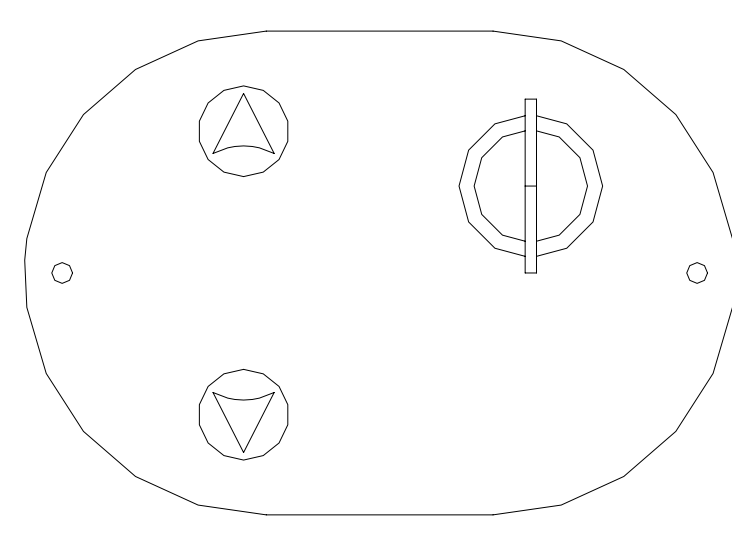

SWITCH-CONTROL,LOFTBED,TOUCH  
189056-01-000  
WIRE ASM-LOFT BED SWITCH  
000122806 / 323456-01-000  
SCREW  
076790-05-000 (2)

DETAIL DK 45B

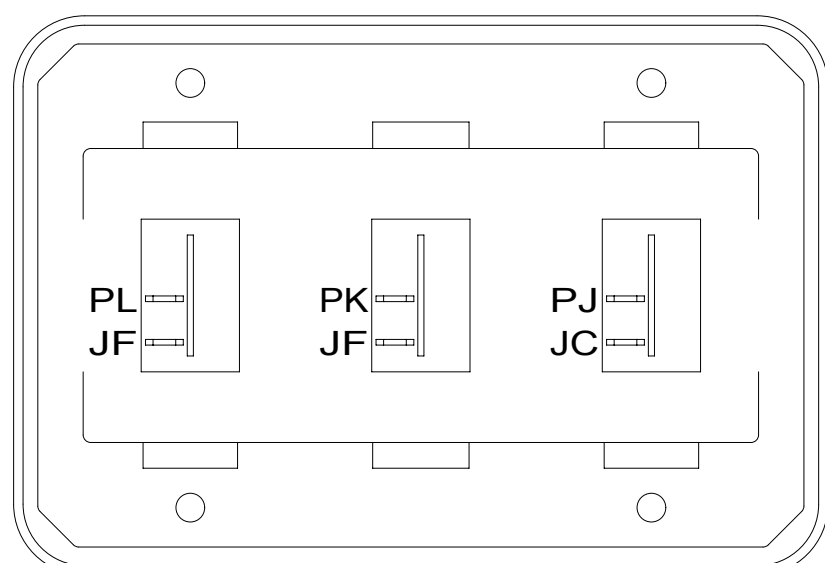

SWITCH-ROCKER  
135740-01-CHT (3)  
SWITCH-BASE  
135741-03-CHT  
SWITCH-BEZEL  
135742-03-CHT  
SCREW  
G11-08-08U (4)

DETAIL DD

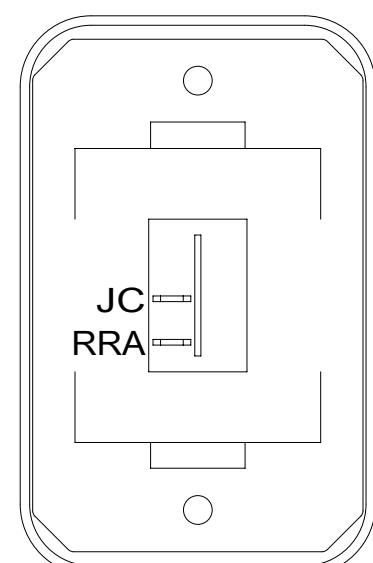

SWITCH-ROCKER  
135740-01-CHT  
SWITCH-BASE  
135741-01-CHT  
SWITCH-BEZEL  
135742-01-CHT  
SCREW  
G11-08-08U (2)

DETAIL DL

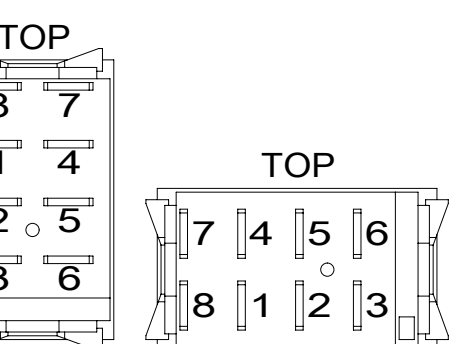

DETAIL DE

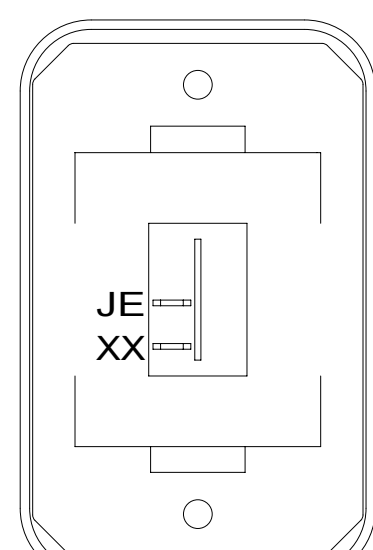

SWITCH-ROCKER  
135740-01-CHT  
SWITCH-BASE  
135741-01-CHT  
SWITCH-BEZEL  
135742-01-CHT  
SCREW  
G11-08-08U (2)

DETAIL DM

LABEL-WARNING,SLIDEOUT  
116549-01-000

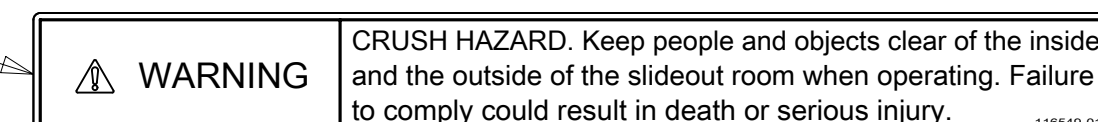

SWITCH-ROCKER  
108357-07-000  
ACTUATOR-SWITCH  
108356-24-CHT  
CIRCUITS  
BBM,DT,BBN

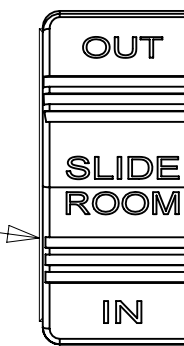

SWITCH  
108357-18-000  
ACTUATOR  
108356-31-CHT  
CIRCUITS  
DU,KE,DR,ABY,ABZ

SWITCH  
108357-18-000  
ACTUATOR  
108356-31-CHT  
CIRCUITS  
HHH,KE,HHG,ACC,ACD

LABEL-SLIDEOUT,  
DRIVER,REAR  
163992-02-CHT



LABEL-SLIDEOUT  
PASS,REAR  
163992-03-CHT

LABEL-SLIDEOUT,  
DRIVER,FRONT  
163992-01-CHT

DETAIL DG

SWITCH-AWNING  
108357-06-000  
ACTUATOR-SWITCH  
108356-12-CHT  
CIRCUITS  
FFD,FFR,FFE,  
FFE,JJR,FFD

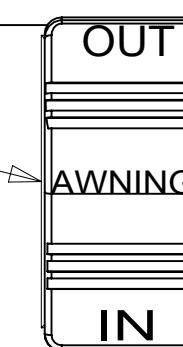

SWITCH-AWNING  
108357-14-000  
ACTUATOR-SWITCH  
108356-28-CHT  
CIRCUITS  
SP,ZZL,WE,ZZL

PLATE-SWITCH  
303611-01-CHT  
SEAL-FUSE BOX  
092492-25-000  
SCREW  
000G11-06-10U (6)

SWITCH-COACH BATT  
108357-18-000  
ACTUATOR-SWITCH  
108356-19-CHT  
CIRCUITS  
KF,LG,LJ,LH,WC  
WIRE ASM-THERM  
186796-01-000

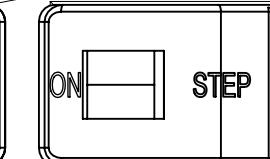
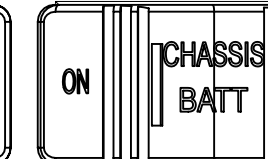
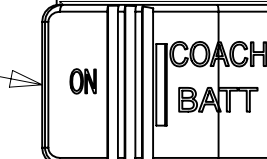

SWITCH-CHASSIS BATTERY  
108357-18-000  
ACTUATOR-SWITCH  
108356-20-CHT  
CIRCUITS  
UUC,TTY,UUB  
UUB,TTZ,MK  
WIRE ASM-THERM  
186796-01-000

SWITCH-STEP  
108357-19-000  
CIRCUITS  
ER,ES

DETAIL DH 1

2 PLACE AROUND ENTIRE PERIMETER WITH SEAM AT BOTTOM.

1 FOR SWITCH ORIENTATION SEE DETAIL DE

NOTES:

FOR ELECTRICAL TORQUE SPECIFICATIONS SEE DWG NO. 128783-01-000

FOR ELECTRICAL CALLOUTS SEE DWG NO. 121339-01-000

- 45B LOFT BED
- 265 CODES/STANDARDS-CSA/CMVSS
- 1B1 CODES/STANDARDS USA

DESCRIPTION:  
**WIRING INSTL-BODY, 12V**

SHEET: 4 OF 7 ITEM/PART NO.: 000124486 / 32393601000 REV

8 7 6 5 4 3 2 1

D

D

C

C

B

B

A

A

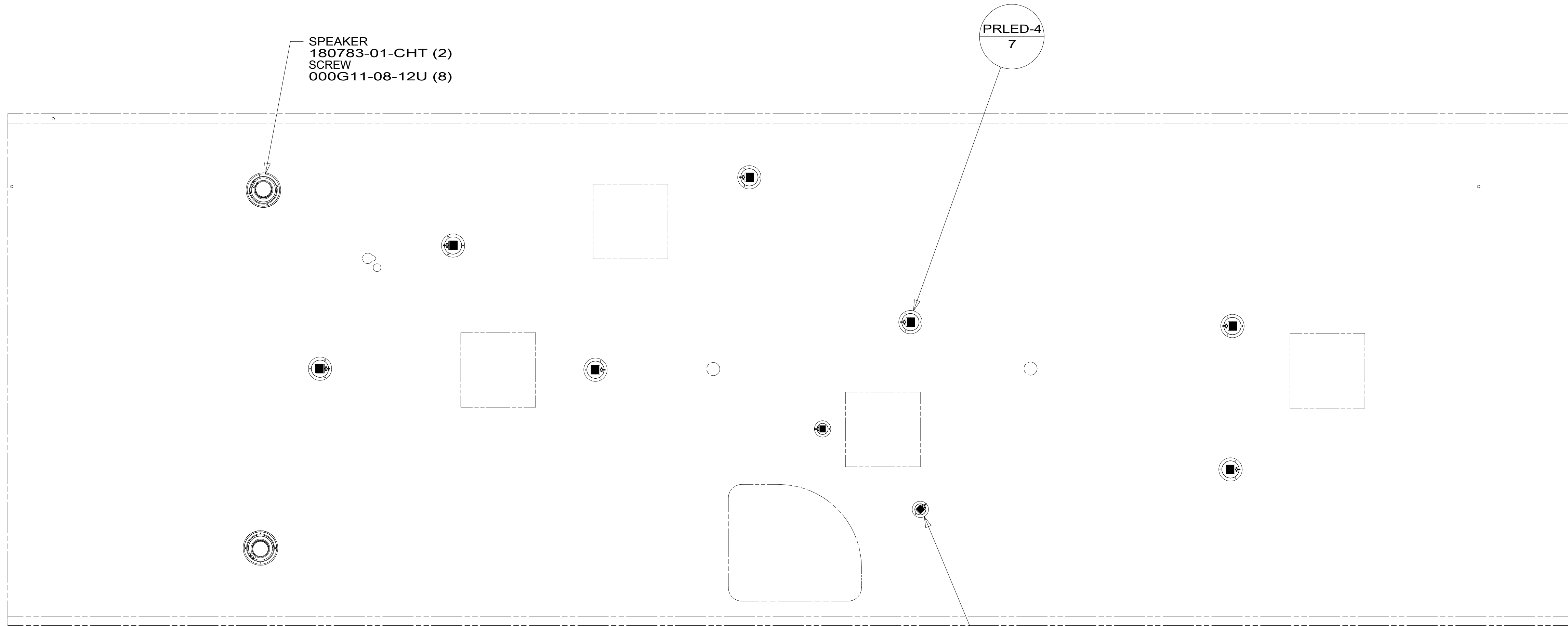

SPEAKER  
 180783-01-CHT (2)  
 SCREW  
 000G11-08-12U (8)

PRLED-4  
 7

PRLED-2  
 2

FOR ELECTRICAL  
 TORQUE  
 SPECIFICATIONS  
 SEE DWG NO.  
 128783-01-000

FOR  
 ELECTRICAL  
 CALLOUTS  
 SEE DWG NO.  
 121339-01-000

265 CODES/STANDARDS-CSA/CMVSS  
 1B1 CODES/STANDARDS USA

|                               |                         |
|-------------------------------|-------------------------|
| DESCRIPTION:                  |                         |
| <b>WIRING INSTL-BODY, 12V</b> |                         |
| SHEET:                        | ITEM/PART NO:           |
| 5 OF 7                        | 000124486 / 32393601000 |
| REV                           |                         |

8 7 6 5 4 3 2 1 12-Jan-2018



8 7 6 5 4 3 2 1

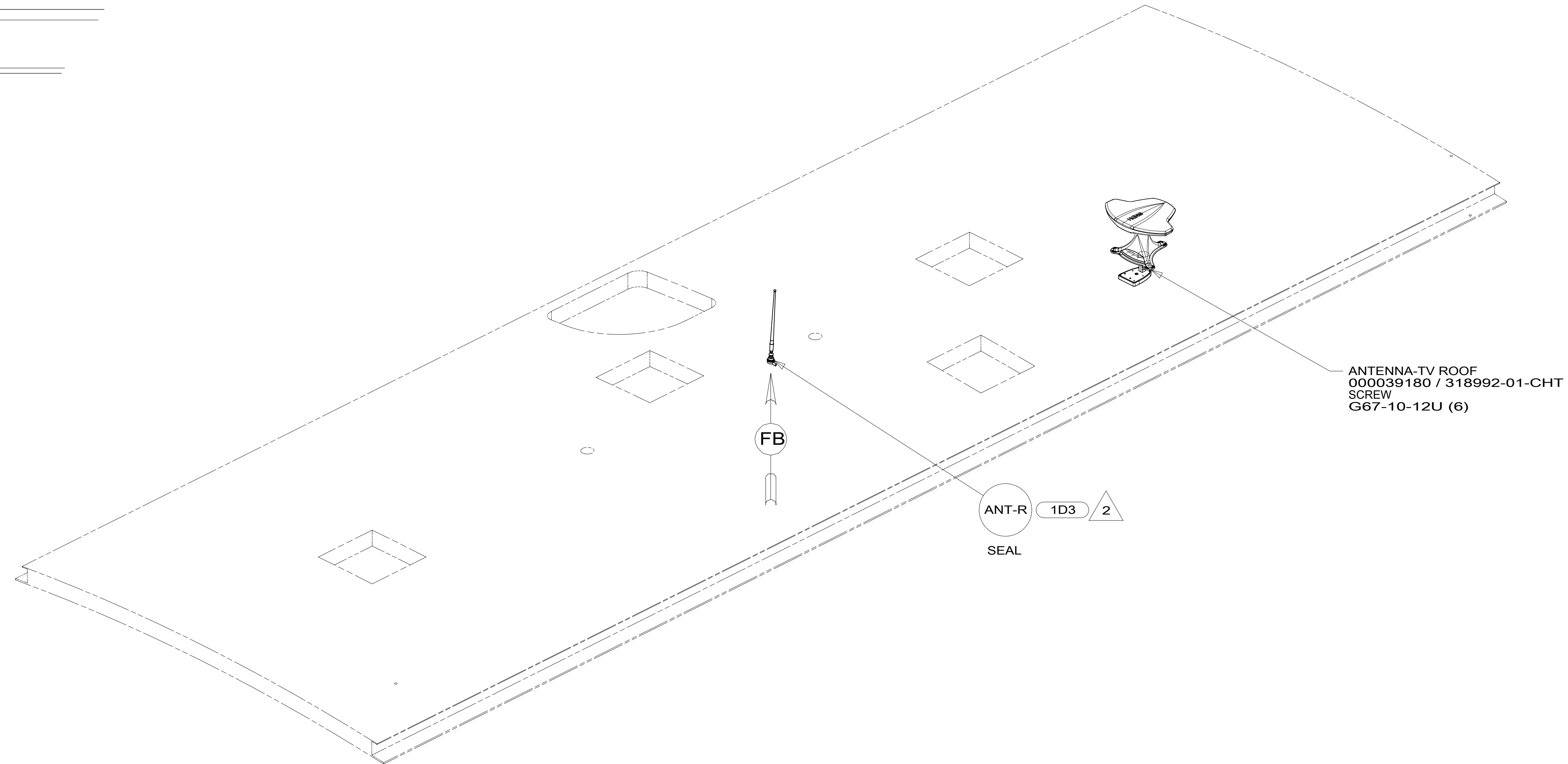
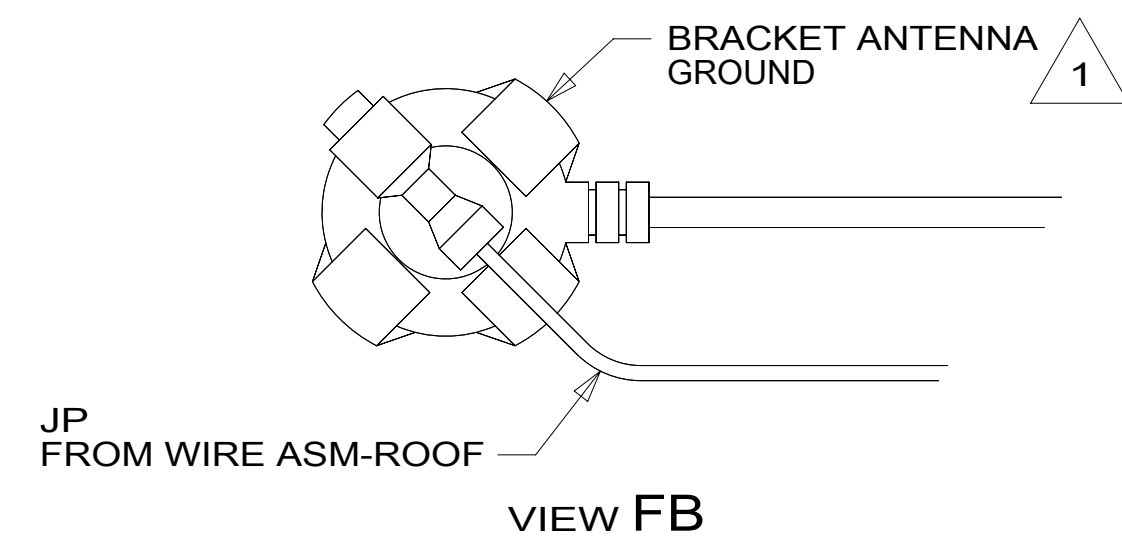
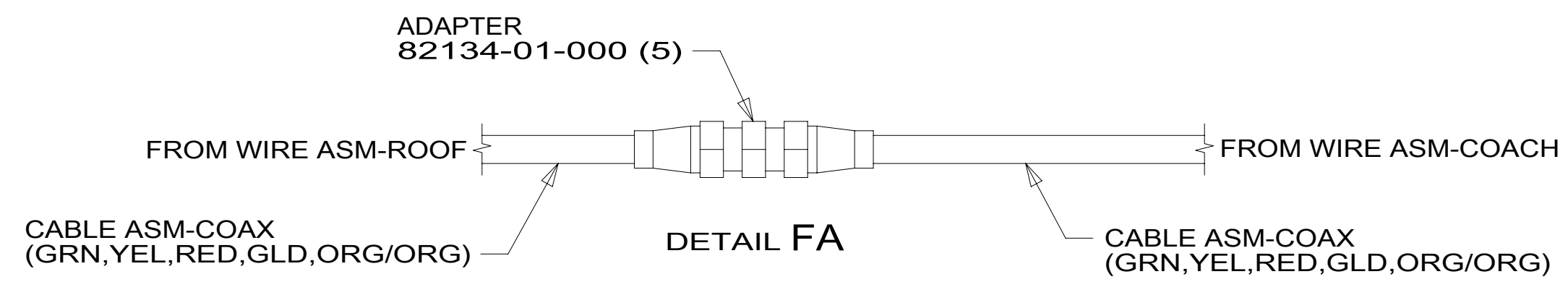

- NOTES:
- 2 REMOVE GROUND WIRE FROM ANTENNA BASE.
  - 1 WRAP LEGS AROUND ANTENNA BASE.

FOR ELECTRICAL  
TORQUE  
SPECIFICATIONS  
SEE DWG NO.  
128783-01-000

FOR  
ELECTRICAL  
CALLOUTS  
SEE DWG NO.  
121339-01-000

- 1D3 ENTERTAIN CENTR/EXT TV-DVD
- 265 CODES/STANDARDS-CSA/CMVSS
- 1B1 CODES/STANDARDS USA

|                               |                         |         |  |
|-------------------------------|-------------------------|---------|--|
| DESCRIPTION:                  |                         | 1B1 265 |  |
| <b>WIRING INSTL-BODY, 12V</b> |                         |         |  |
| SHEET:                        | ITEM/PART NO.:          | REV     |  |
| 6 OF 7                        | 000124486 / 32393601000 |         |  |

8 7 6 5 4 3 2 1 12-Jan-2018

8 7 6 5 4 3 2 1

D  
C  
B  
A

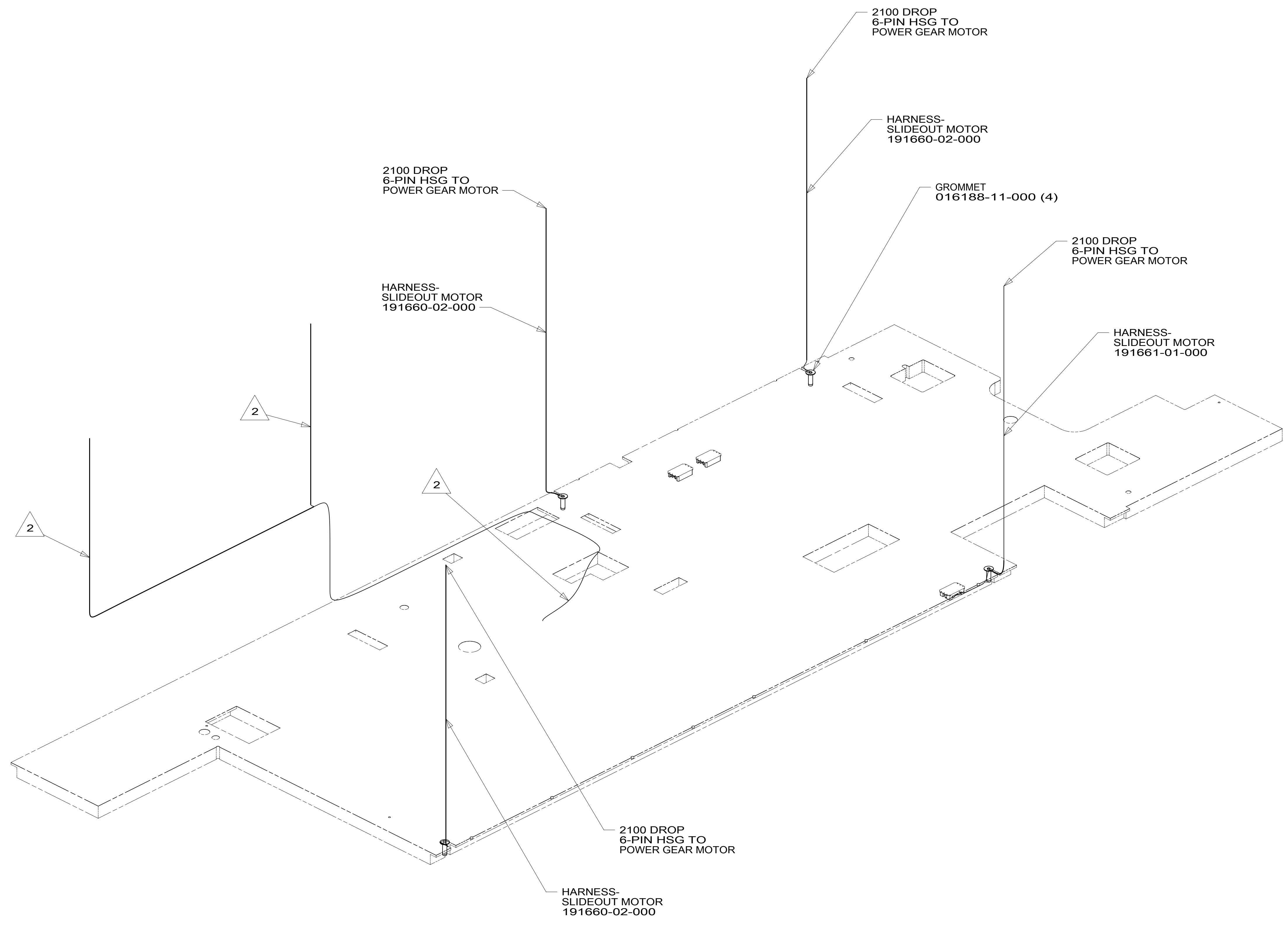

 WIRING PART OF WIRE ASM-CHASSIS.

1. AT MINIMUM ALL WIRES TO BE SUPPORTED AND SECURED PER CODE REQUIREMENTS. USE CLAMP 10495 OR 10497 OR WIRE TIE 8343 OR 108046 AND SCREW G67-XX-XXX OR G56-XX-XXX AS APPROPRIATE FOR INSTALLATION.

NOTES:

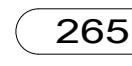
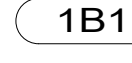
 CODES/STANDARDS-CSA/CMVSS  
 CODES/STANDARDS USA

FOR ELECTRICAL TORQUE SPECIFICATIONS SEE DWG NO. 128783-01-000

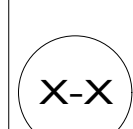
 FOR ELECTRICAL CALLOUTS SEE DWG NO. 121339-01-000

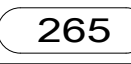
|   |  |
|---|--|
|   |  |
| DESCRIPTION:<br><b>WIRING INSTL-BODY, 12V</b>   |  |
| SHEET:<br>7 OF 7  | ITEM/PART NO:<br>000124486 / 32393601000 |
| REV   |  |

8 7 6 5 4 3 2 1 12-Jan-2018