

4 45B WIRE ASM-BED LIFT
195046-01-000

36N FAN-DEFROSTER
122856-01-CHT (2)
SCREW
G39-08-16E (6)
BUTT SPLICE TO FANS
LE-GRN
LF-YEL
XW-BLK

WIRE ASM-IP,MAIN

CB POWER PROVISION
YELLOW +12V
WHITE GROUND
COAX ANTENNA
(SEE REVERSE SIDE ALSO)

TO CUSTOMERS
CB RADIO WIRING

WHT YEL

DETAIL AA 579

3 LABEL-CB PREP
OPTION
104678-01-000

45D 3 PIN HOUSING
TO SIDEWALL

45B 3 PIN HSG
TO WIRE ASM-
BED LIFT

45D READ-4

WIRE ASM-IP,MAIN
000124495 / 323940-01-000

RING TERMINAL (5)
TO GROUND BOLT

TO RELAYS

CLIP-WIRE, NYLON
080734-02-000
TIE-WIRE
008343-01-000

6 PIN HOUSING
TO LEFT MIRROR

579 BUTT SPLICE (2)
TO CB PREP
DETAIL AA

12 & 4 PIN HOUSINGS
TO SIDEWALL

GROMMET
023942-02-000

TO GROUND STUD

2 PIN HOUSING
CONNECTS TO WIRE ASM-
CLEARANCE FRONT

45B 6 PIN HOUSING
TO ROOF

12 PIN HOUSING
TO ROOF

SPEAKER
94097-01-000 (2)
SCREW
G11-08-20U (6)

5 TO SUNVISOR SHADE
3 BUTT SPLICES
HHM-BLK
HHN-RED
KE-BRN

READ-4 45D

TAPE (2)
(400MM) 2

6 PIN HOUSING
TO RIGHT MIRROR

SWITCH-MAP LIGHT
174757-20-CHT
PANEL-SWITCH
MOUNTING,SINGLE
174834-01-CHT

USB-CHARGER DUAL,DC
188312-01-000

RECEPTACLE-12V
111414-01-000

4 PIN HSG TO PASS
MAP LAMP SWITCH

- 36N FANS-DEFROSTER, AUXILIARY
- 45D LOFT BED - WITHOUT
- 45B LOFT BED
- 579 RADIO - CB WIRE PREP
- 265 CODES/STANDARDS-CSA/CMVSS
- 1B1 CODES/STANDARDS USA

1B1 265



DSNR:		ALL DIMENSIONS ARE IN MILLIMETERS	
DIFFR:		MATERIAL:	
UNSPECIFIED TOLERANCES:			
WHOLE DIM (X)	: 3		
ONE-PLACE (X.X)	: 1.5		
TWO-PLACE (X.XX)	: 0.50		
ANGLE	: 1°		
REFER TO ES0018 FOR FASTENER TIGHTENING GUIDELINES		WEIGHT: (LBS)	FIRST USED:
			18 E-LX-SER
DESCRIPTION: WIRING INSTL-FRONT END			
SHEET:	ITEM/PART NO.:	REV	
1 OF 9	000124466 / 32393101000		
REF:		1 29-Jan-2018	

- 5 CUT VISOR WIRING TO 300 MM BEFORE CONNECTING.
- 4 SEE SHEET 9 FOR ADDITIONAL INFORMATION ON LOFT BED.
- 3 EDGE OF LABEL TO HANG JUST BELOW BOTTOM OF DASH.
- 2 USE TAPE 8363-03-000 TO SECURE WIRES IN A-POST.

1. WINNEBAGO WIRE ASSEMBLIES ARE SHOWN FOR CLARITY.

NOTES:

FOR ELECTRICAL
TORQUE
SPECIFICATIONS
SEE DWG NO.
128783-01-000

FOR ELECTRICAL
CALLOUTS
SEE DWG NO.
121339-01-000

12 PIN HSG
TO WIRE
ASM-CHASSIS

BREAKER PANEL
DETAIL BA

DETAIL CA
3,4, & 6 PIN HOUSINGS
TO LEVELING SYSTEM CONTROLS

FEMALE TERMINALS
TO JACKS DOWN LAMP

WIRING TO LOFT BED 4

CIRCUIT BREAKER-6 AMP
093654-01-000
SCREW
G52-06-05U
LOCK WASHER
OME02B-04-071

CIRCUIT BREAKER-25 AMP
93655-01-000
SCREW
G52-06-04B
G52-06-05B
LOCKWASHER
OME02B-04-071

BRACKET-FUSE PANEL
149690-02-CHT
SCREW
000G11-10-08B (4)

CIRCUIT BREAKER-15 AMP
93654-02-000 (3)
SCREW
G52-06-05B (3)
LOCKWASHER
OME02B-04-071 (3)

CIRCUIT BREAKER-25 AMP
93655-01-000
SCREW
G52-06-04B
G52-06-05B
LOCKWASHER
OME02B-04-071

BRACKET-CIRCUIT BREAKER
149689-01-CHT
SCREW
000G11-10-08B (4)

LABEL-CIRCUIT BREAKER
93236-66-000

BREAKER-SELF RESET, 20 AMP
182283-01-000
SCREW
G52-06-04B
WASHER-LOCK
OME02B-04-071

CIRCUIT BREAKER-30 AMP
93655-02-000
SCREW
G52-06-04B
G52-06-05B
LOCKWASHER
OME02B-04-071

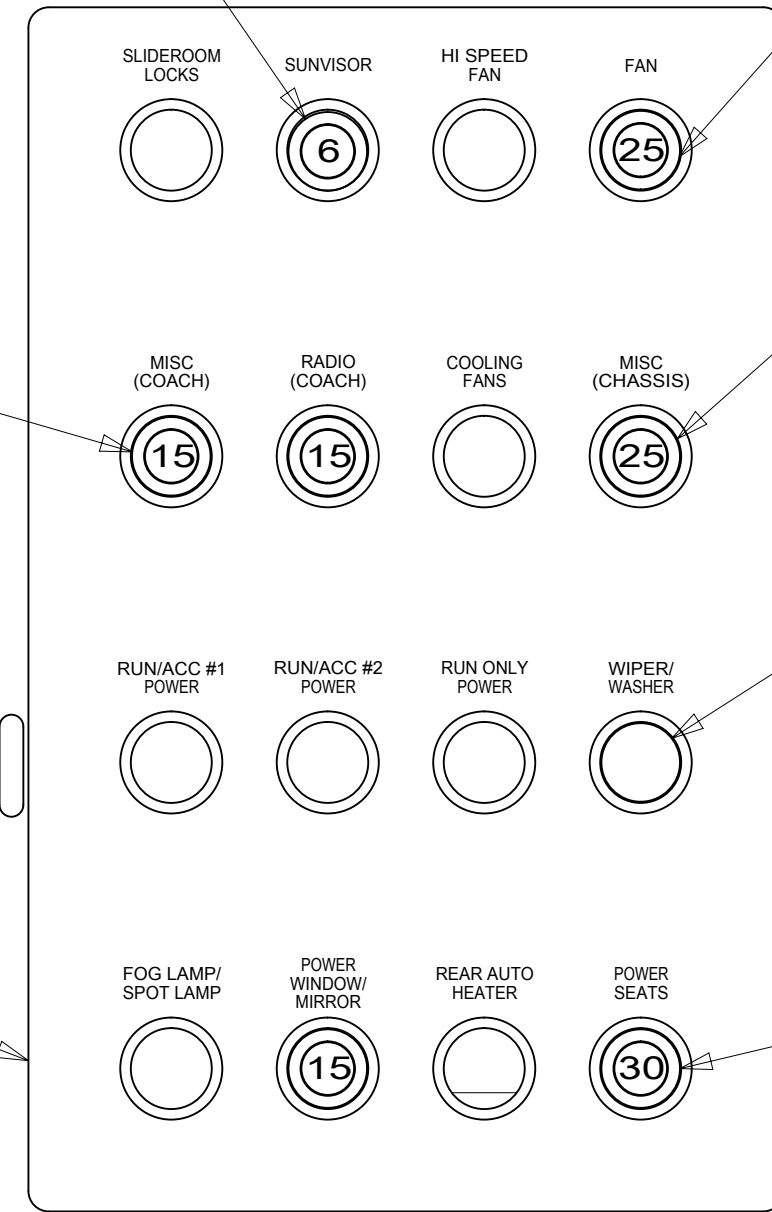

VIEW BB

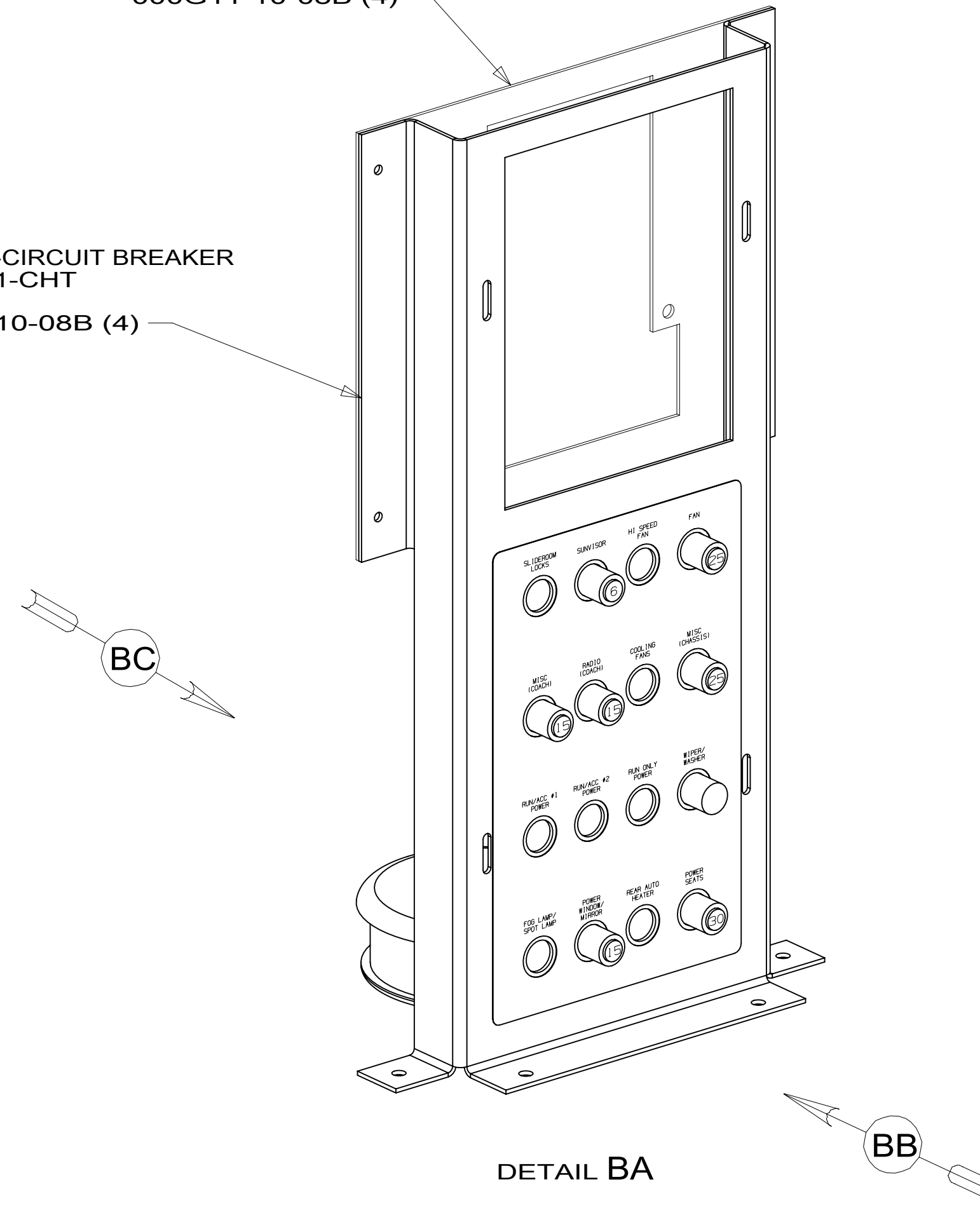

DETAIL BA

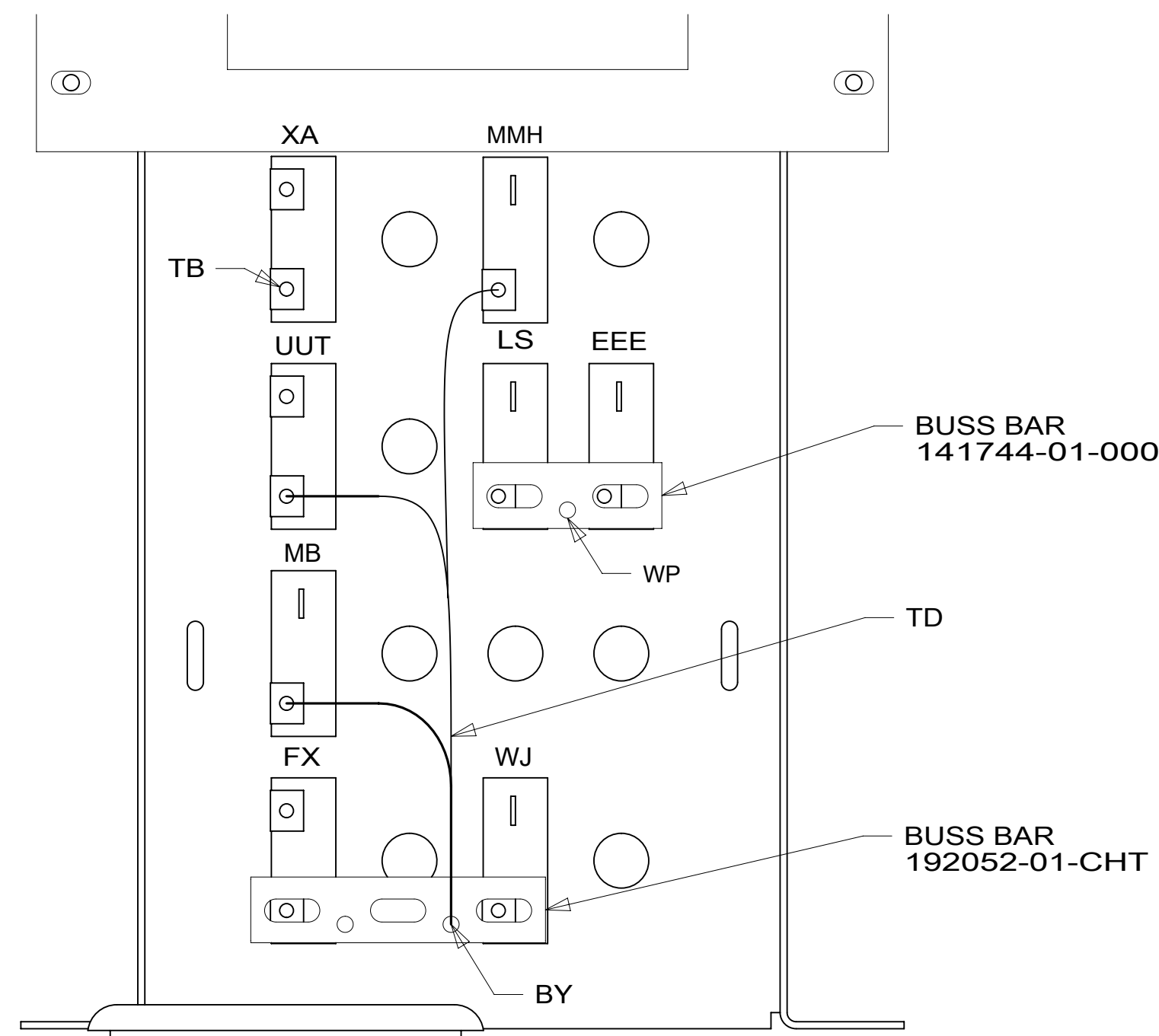

VIEW BC 1

1 ALL CIRCUITS ARE IN WIRE ASM-IP,MAIN.
NOTES:

265 CODES/STANDARDS-CSA/CMVSS

1B1 CODES/STANDARDS USA

1B1 265

FOR ELECTRICAL TORQUE SPECIFICATIONS SEE DWG NO. 128783-01-000

X-X FOR ELECTRICAL CALLOUTS SEE DWG NO. 121339-01-000

DESCRIPTION:
WIRING INSTL-FRONT END

SHEET:	ITEM/PART NO:	REV
2 OF 9	000124466 / 32393101000	

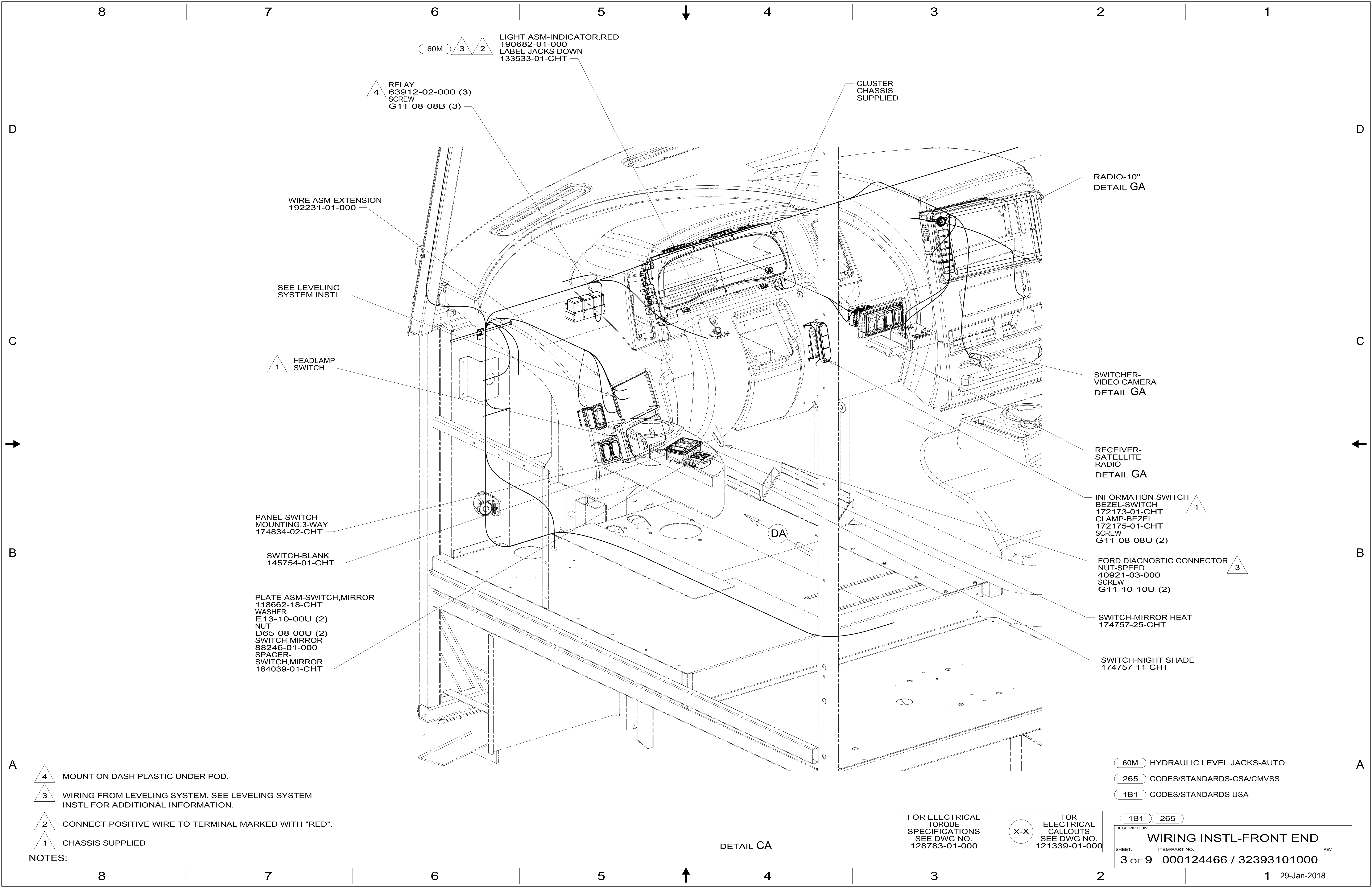

60M 3 2 LIGHT ASM-INDICATOR,RED
190682-01-000
LABEL-JACKS DOWN
133533-01-CHT

4 RELAY
63912-02-000 (3)
SCREW
G11-08-08B (3)

CLUSTER
CHASSIS
SUPPLIED

WIRE ASM-EXTENSION
192231-01-000

RADIO-10"
DETAIL GA

SEE LEVELING
SYSTEM INSTL

1 HEADLAMP
SWITCH

SWITCHER-
VIDEO CAMERA
DETAIL GA

PANEL-SWITCH
MOUNTING,3-WAY
174834-02-CHT

RECEIVER-
SATELLITE
RADIO
DETAIL GA

SWITCH-BLANK
145754-01-CHT

INFORMATION SWITCH
BEZEL-SWITCH
172173-01-CHT
CLAMP-BEZEL
172175-01-CHT
SCREW
G11-08-08U (2)

PLATE ASM-SWITCH,MIRROR
118662-18-CHT
WASHER
E13-10-00U (2)
NUT
D65-08-00U (2)
SWITCH-MIRROR
88246-01-000
SPACER-
SWITCH,MIRROR
184039-01-CHT

FORD DIAGNOSTIC CONNECTOR
NUT-SPEED
40921-03-000
SCREW
G11-10-10U (2)

SWITCH-MIRROR HEAT
174757-25-CHT

SWITCH-NIGHT SHADE
174757-11-CHT

- NOTES:
- 4 MOUNT ON DASH PLASTIC UNDER POD.
 - 3 WIRING FROM LEVELING SYSTEM. SEE LEVELING SYSTEM INSTL FOR ADDITIONAL INFORMATION.
 - 2 CONNECT POSITIVE WIRE TO TERMINAL MARKED WITH "RED".
 - 1 CHASSIS SUPPLIED

- 60M HYDRAULIC LEVEL JACKS-AUTO
- 265 CODES/STANDARDS-CSA/CMVSS
- 1B1 CODES/STANDARDS USA

FOR ELECTRICAL
TORQUE
SPECIFICATIONS
SEE DWG NO.
128783-01-000

X-X FOR
ELECTRICAL
CALLOUTS
SEE DWG NO.
121339-01-000

DESCRIPTION:	
1B1 265	
WIRING INSTL-FRONT END	
SHEET:	ITEM/PART NO:
3 OF 9	000124466 / 32393101000
REV	

DETAIL CA

8 7 6 5 4 3 2 1

D
C
B
A

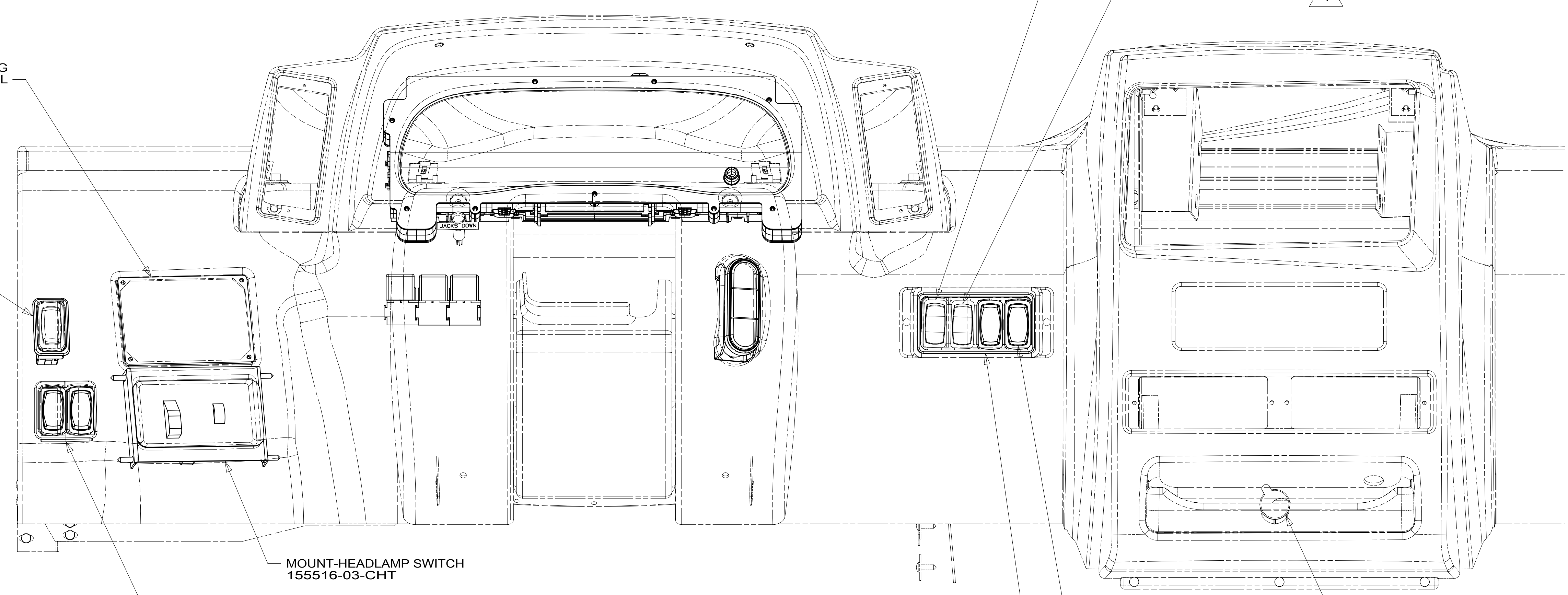

VIEW DA

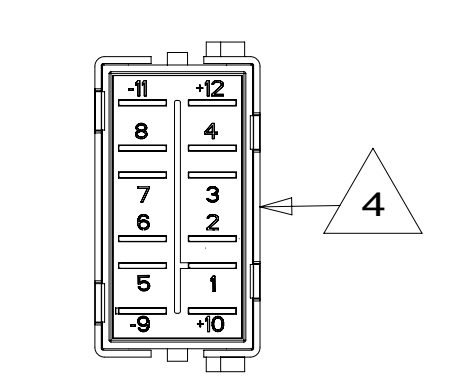

DETAIL DB (MOUNTED VERTICALLY)

- NOTES:
- 4 WITH SWITCH INSTALLED THIS SIDE OF SWITCH WILL FACE LEFT SIDEWALL.
 - 3 DETAIL IS LOOKING AT SWITCH FROM THE BACK SIDE OF SWITCH AS ITS INSTALLED.
 - 2 SEE DETAIL DB FOR ORIENTATION.
 - 1 WITHOUT 36N

- 36N FANS-DEFROSTER, AUXILIARY
- 265 CODES/STANDARDS-CSA/CMVSS
- 1B1 CODES/STANDARDS USA

FOR ELECTRICAL TORQUE SPECIFICATIONS SEE DWG NO. 128783-01-000

FOR ELECTRICAL CALLOUTS SEE DWG NO. 121339-01-000

DESCRIPTION:		1B1 265
WIRING INSTL-FRONT END		
SHEET:	ITEM/PART NO.:	REV
4 OF 9	000124466 / 32393101000	

8 7 6 5 4 3 2 1 29-Jan-2018

8 7 6 5 4 3 2 1

D
C
B
A

D
C
B
A

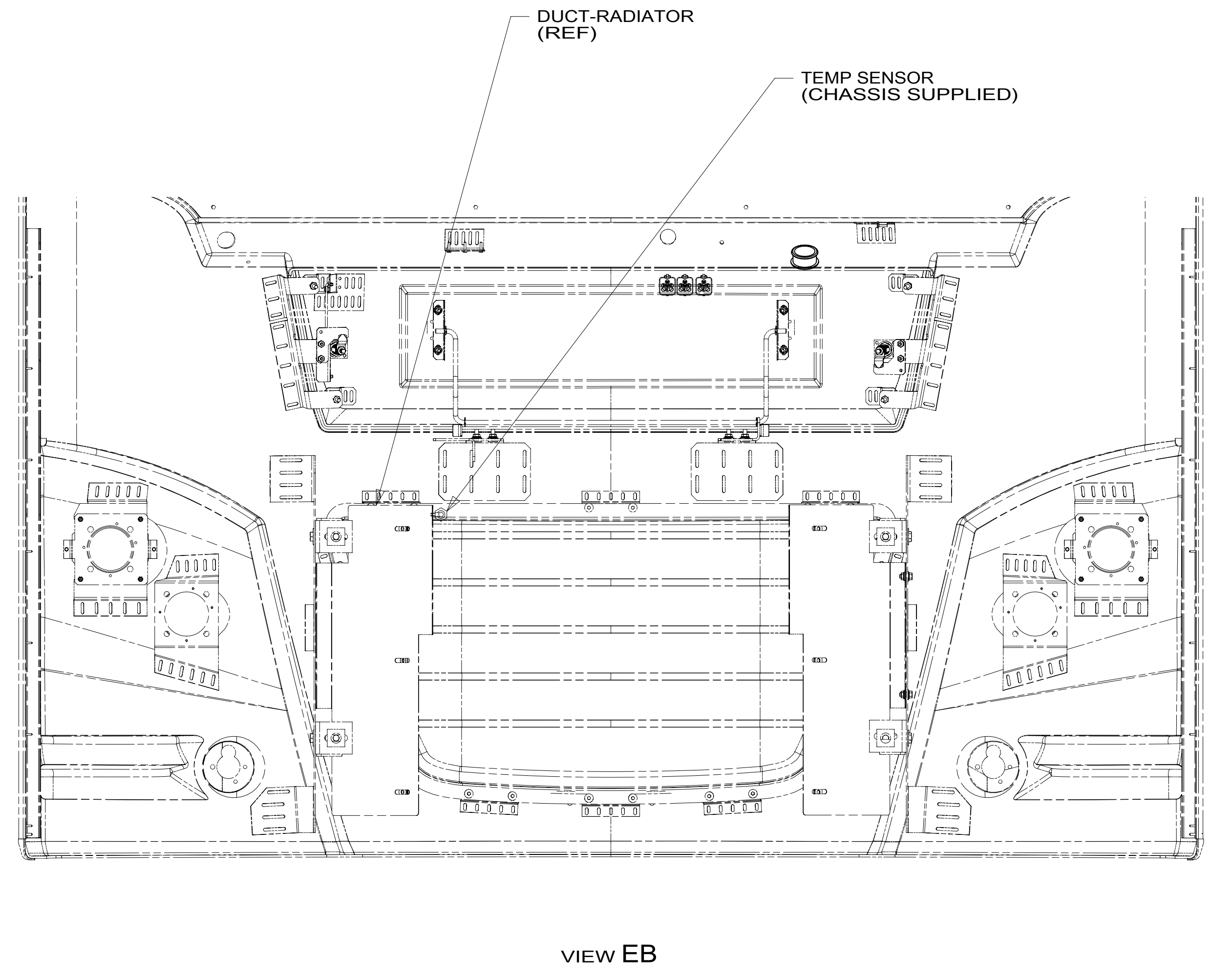
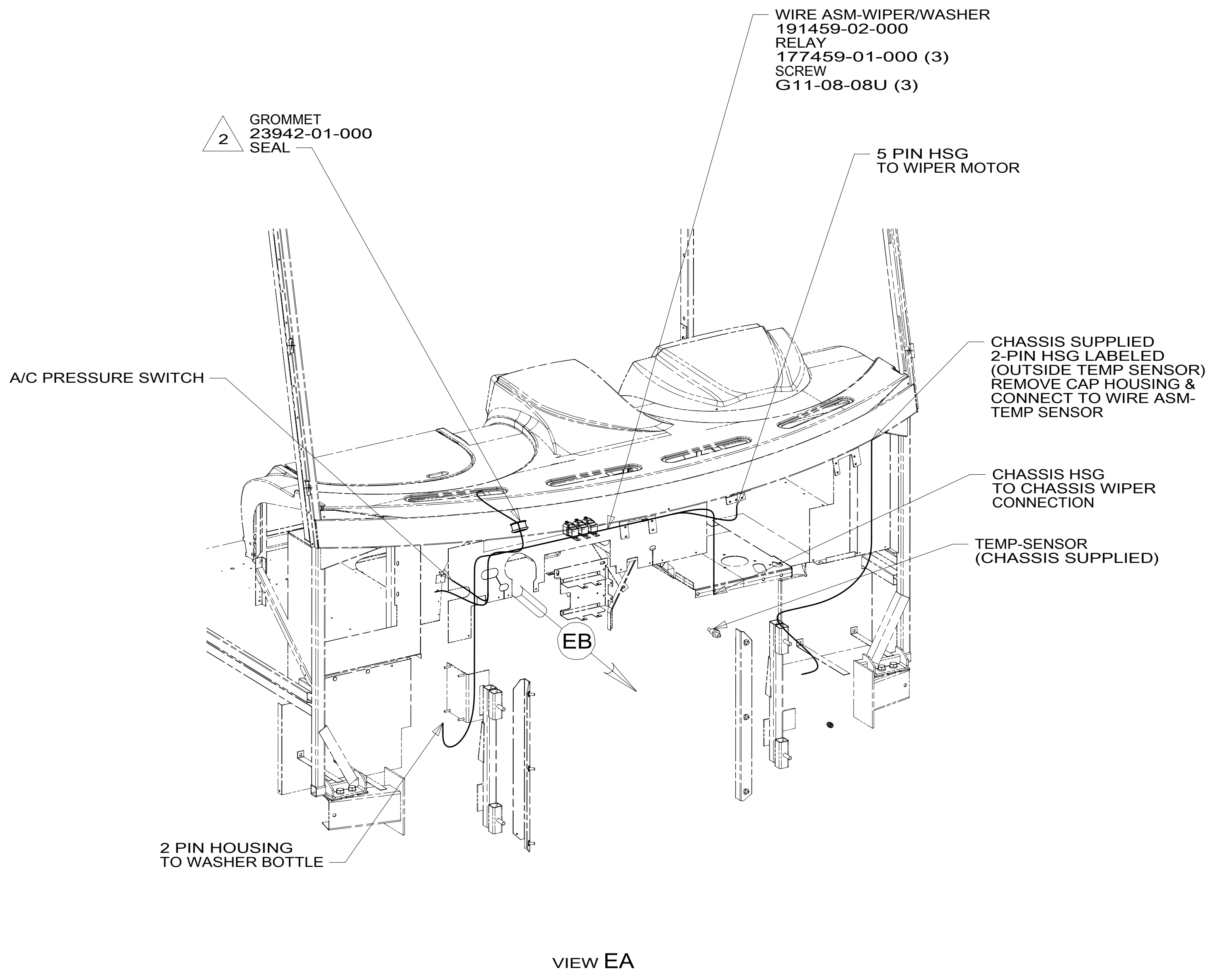

- 2 ROUTE WIRES THROUGH HOLE IN STEEL.
- GATHER ALL EXCESS WIRE AFTER MAKING ALL CONNECTIONS. BUNDLE AND SECURE WITH WIRE TIE 8343-01-000 OR 93147-01-000.
- NOTES:

FOR ELECTRICAL TORQUE SPECIFICATIONS SEE DWG NO. 128783-01-000

FOR ELECTRICAL CALLOUTS SEE DWG NO. 121339-01-000

265 CODES/STANDARDS-CSA/CMVSS
1B1 CODES/STANDARDS USA

DESCRIPTION: WIRING INSTL-FRONT END	
SHEET: 5 OF 9	ITEM/PART NO: 000124466 / 32393101000
REV	

8 7 6 5 4 3 2 1 29-Jan-2018

8 7 6 5 4 3 2 1

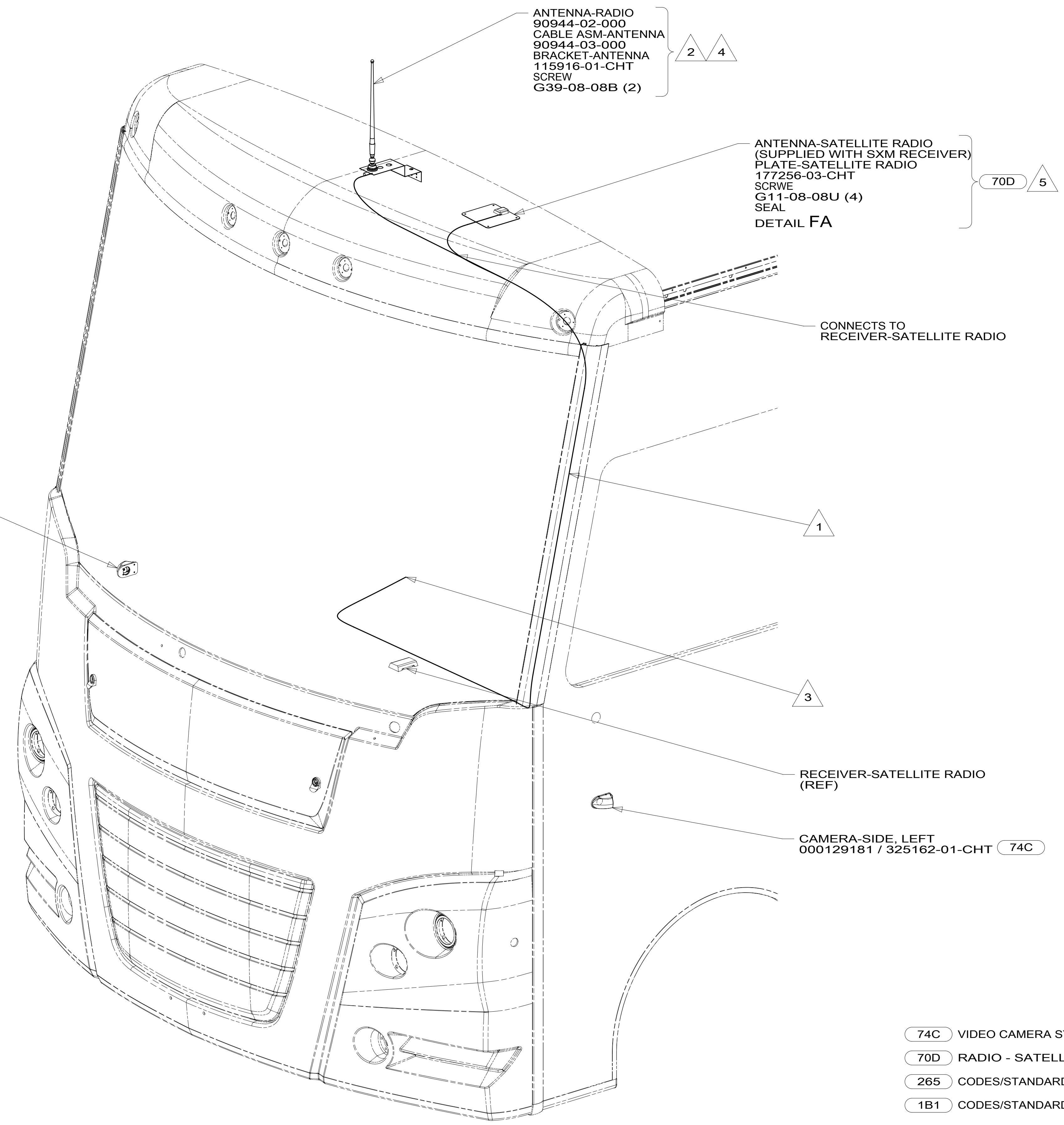
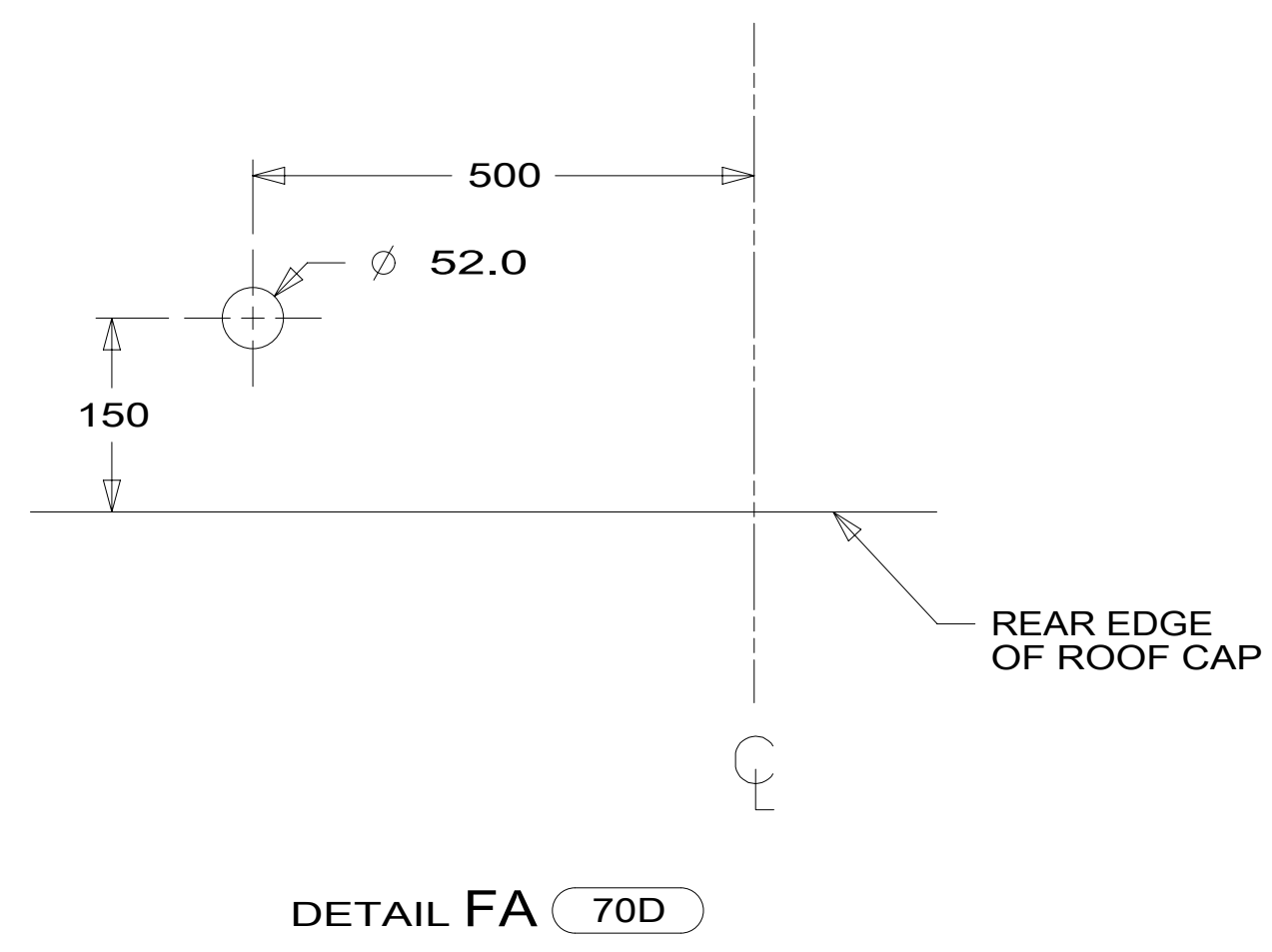

- NOTES:
- 5 MOUNT ANTENNA SUCH THAT BASE IS SQUARE W/REAR OF ROOF CAP & HOLE IS DIRECTLY OVER HOLE IN FIBERGLASS. SEAL HOLE IN ROOF CAP, BASE AT SCREWS.
 - 4 USE HOLE IN BRACKET AS GUIDE TO DRILL 13 MM DIAMETER HOLE IN FIBERGLASS.
 - 3 TO RADIO.
 - 2 SEAL AROUND ANTENNA BASE.
 - 1 ROUTE CABLES ALONG A-POST, UNDER TRIM COVER.

- 74C VIDEO CAMERA SYSTEM
- 70D RADIO - SATELLITE SIRIUSXM
- 265 CODES/STANDARDS-CSA/CMVSS
- 1B1 CODES/STANDARDS USA

FOR ELECTRICAL TORQUE SPECIFICATIONS SEE DWG NO. 128783-01-000

FOR ELECTRICAL CALLOUTS SEE DWG NO. 121339-01-000

DESCRIPTION:	
1B1 265	
WIRING INSTL-FRONT END	
SHEET:	ITEM/PART NO:
6 OF 9	000124466 / 32393101000
REV	

8 7 6 5 4 3 2 1 29-Jan-2018

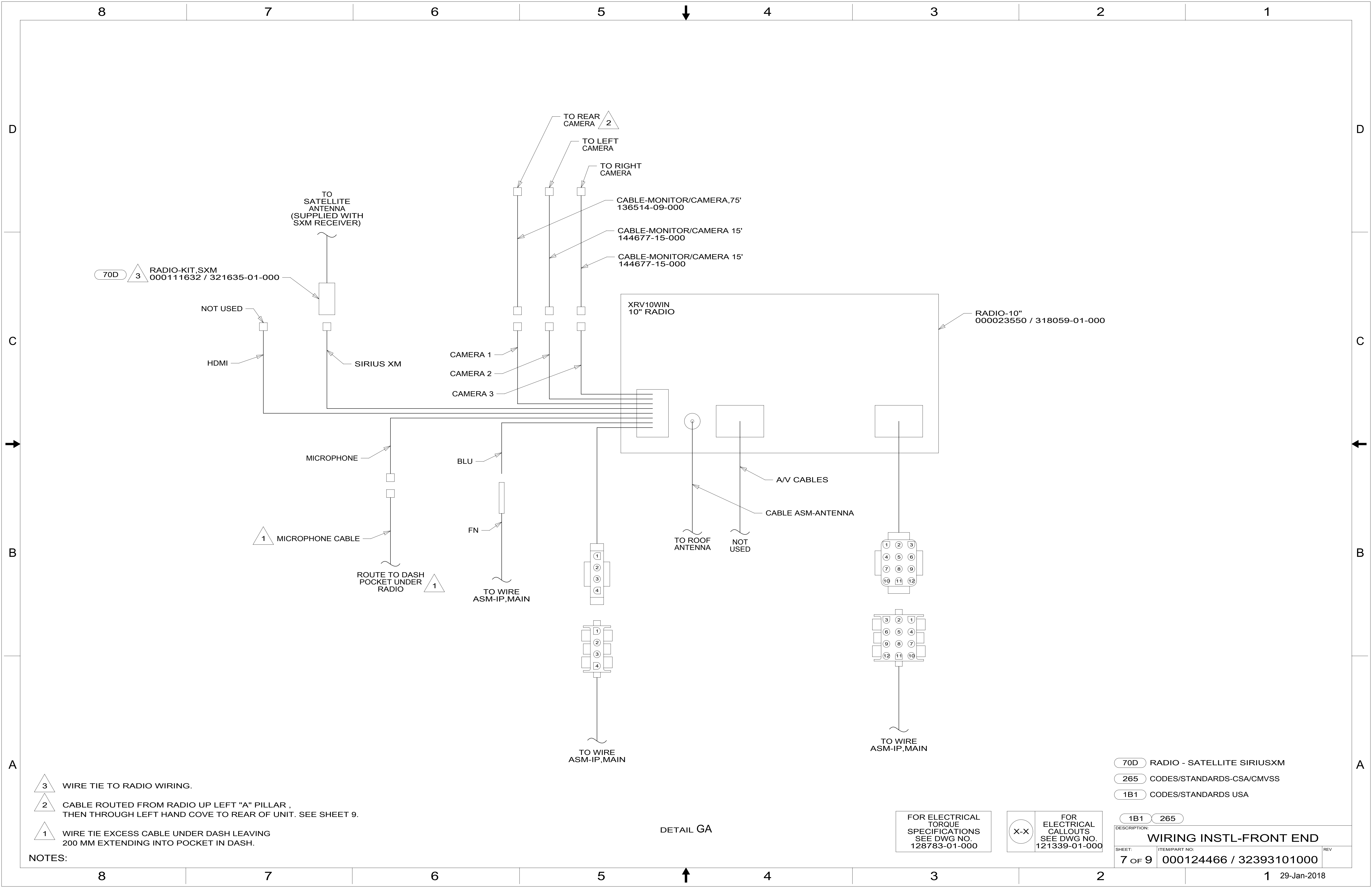

- NOTES:
- 3 WIRE TIE TO RADIO WIRING.
 - 2 CABLE ROUTED FROM RADIO UP LEFT "A" PILLAR , THEN THROUGH LEFT HAND COVE TO REAR OF UNIT. SEE SHEET 9.
 - 1 WIRE TIE EXCESS CABLE UNDER DASH LEAVING 200 MM EXTENDING INTO POCKET IN DASH.

DETAIL GA

FOR ELECTRICAL TORQUE SPECIFICATIONS SEE DWG NO. 128783-01-000

FOR ELECTRICAL CALLOUTS SEE DWG NO. 121339-01-000

- 70D RADIO - SATELLITE SIRIUSXM
- 265 CODES/STANDARDS-CSA/CMVSS
- 1B1 CODES/STANDARDS USA

DESCRIPTION:		1B1 265	
WIRING INSTL-FRONT END			
SHEET:	ITEM/PART NO.:	REV	
7 OF 9	000124466 / 32393101000		

8 7 6 5 4 3 2 1

D
C
B
A

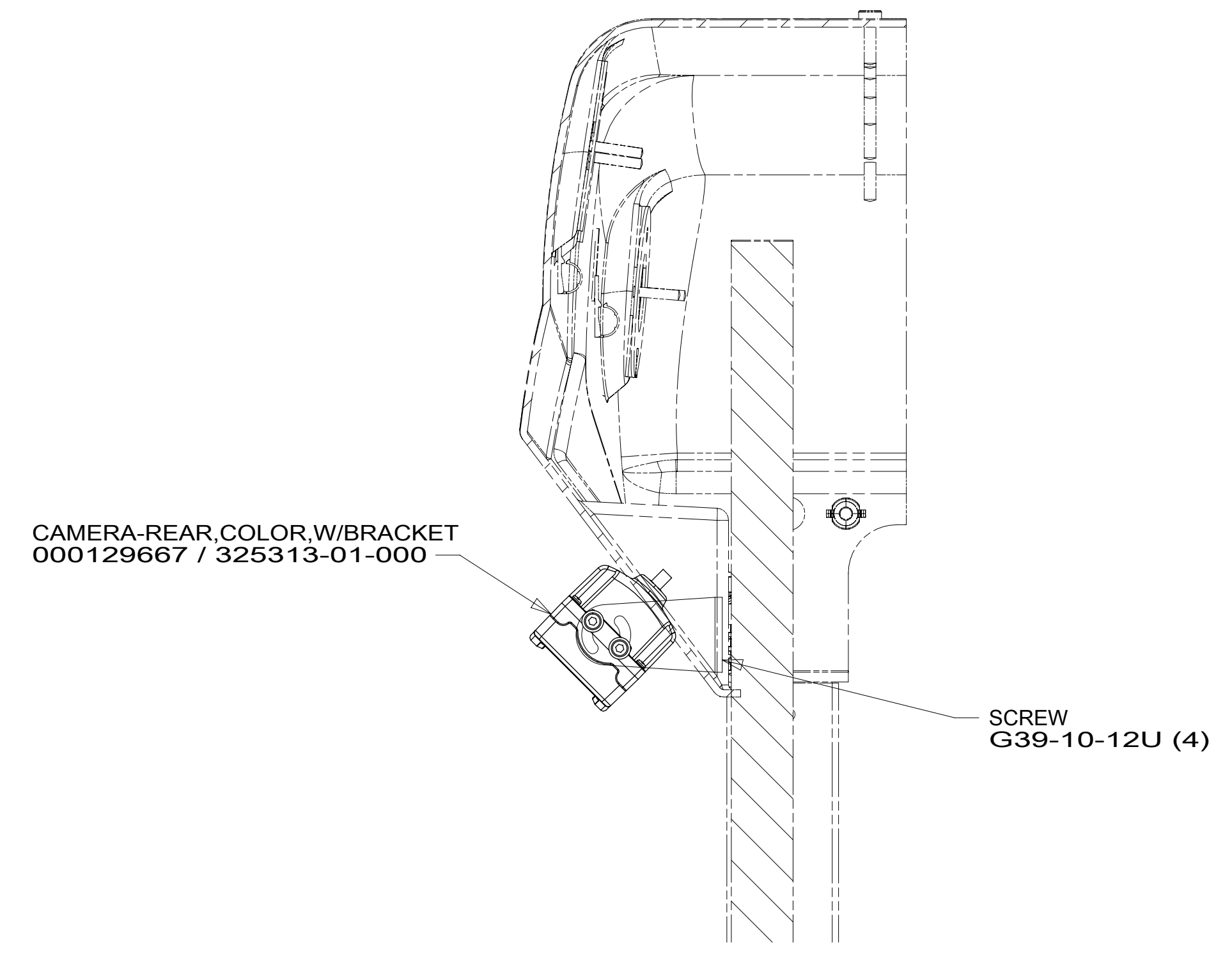
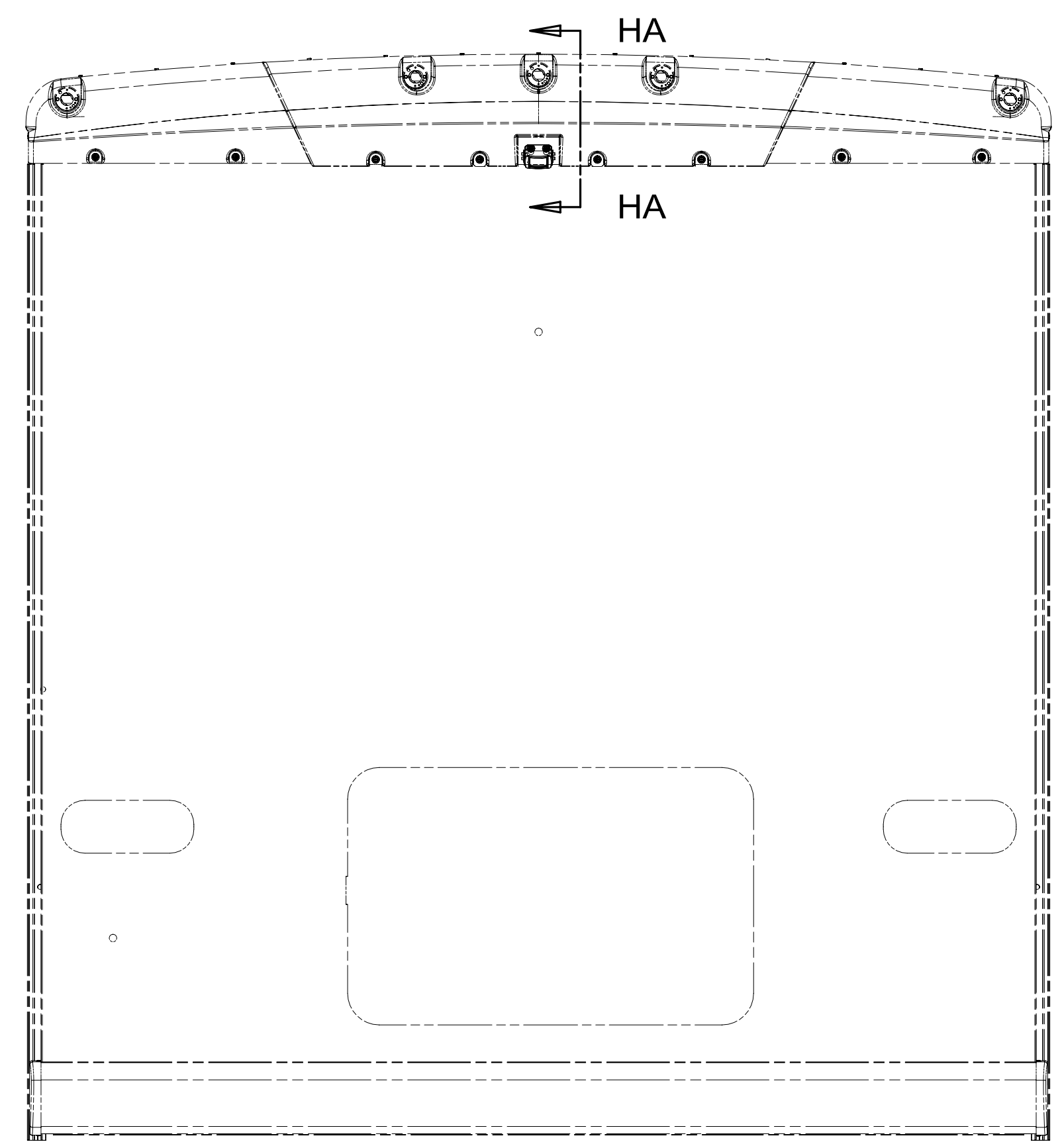
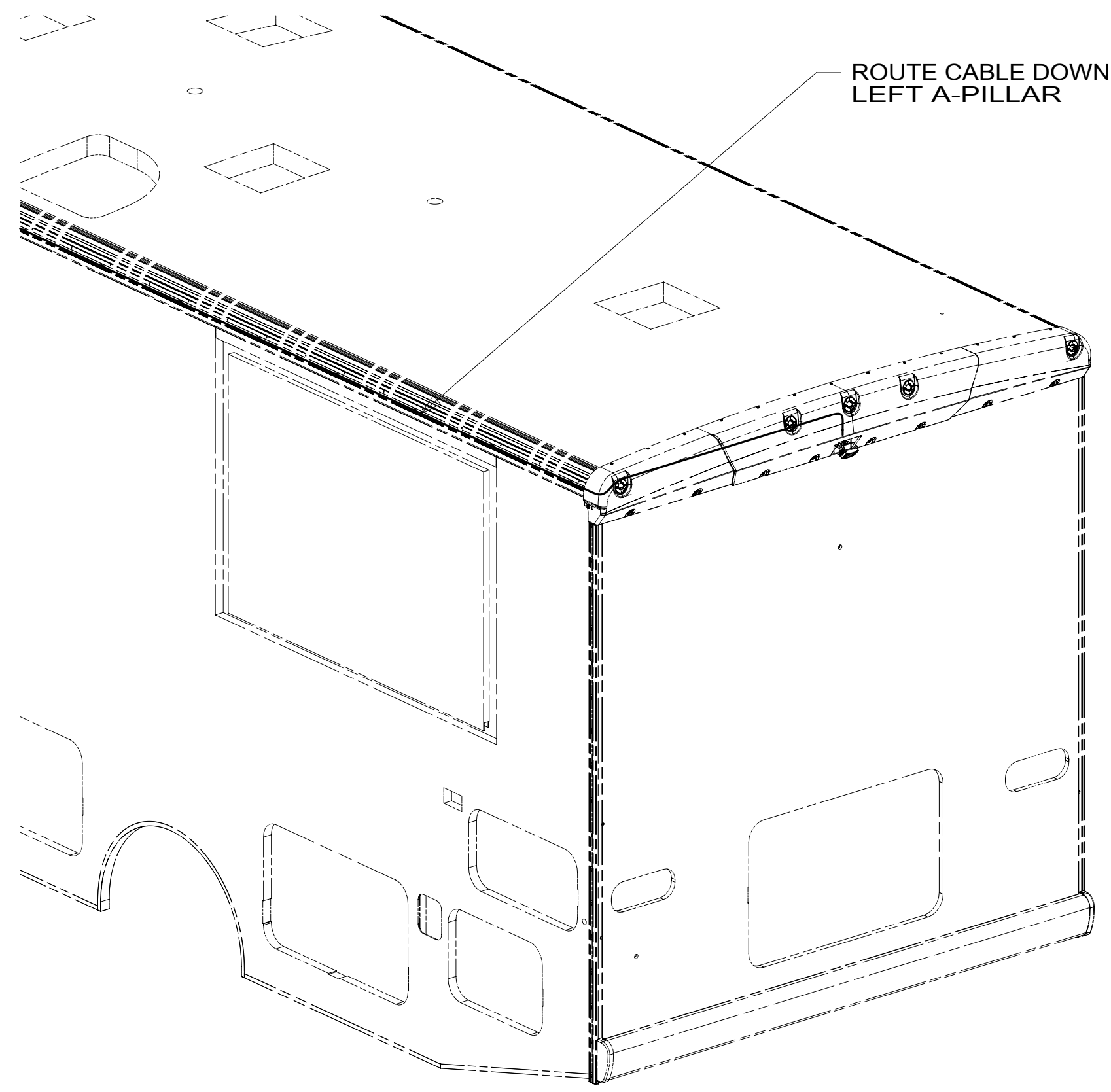

SECTION HA-HA

D
C
B
A

8 7 6 5 4 3 2 1

FOR ELECTRICAL TORQUE SPECIFICATIONS SEE DWG NO. 128783-01-000

X-X FOR ELECTRICAL CALLOUTS SEE DWG NO. 121339-01-000

- 265 CODES/STANDARDS-CSA/CMVSS
- 1B1 CODES/STANDARDS USA

DESCRIPTION: WIRING INSTL-FRONT END	
SHEET: 8 OF 9	ITEM/PART NO.: 000124466 / 32393101000
REV	

8 7 6 5 4 3 2 1

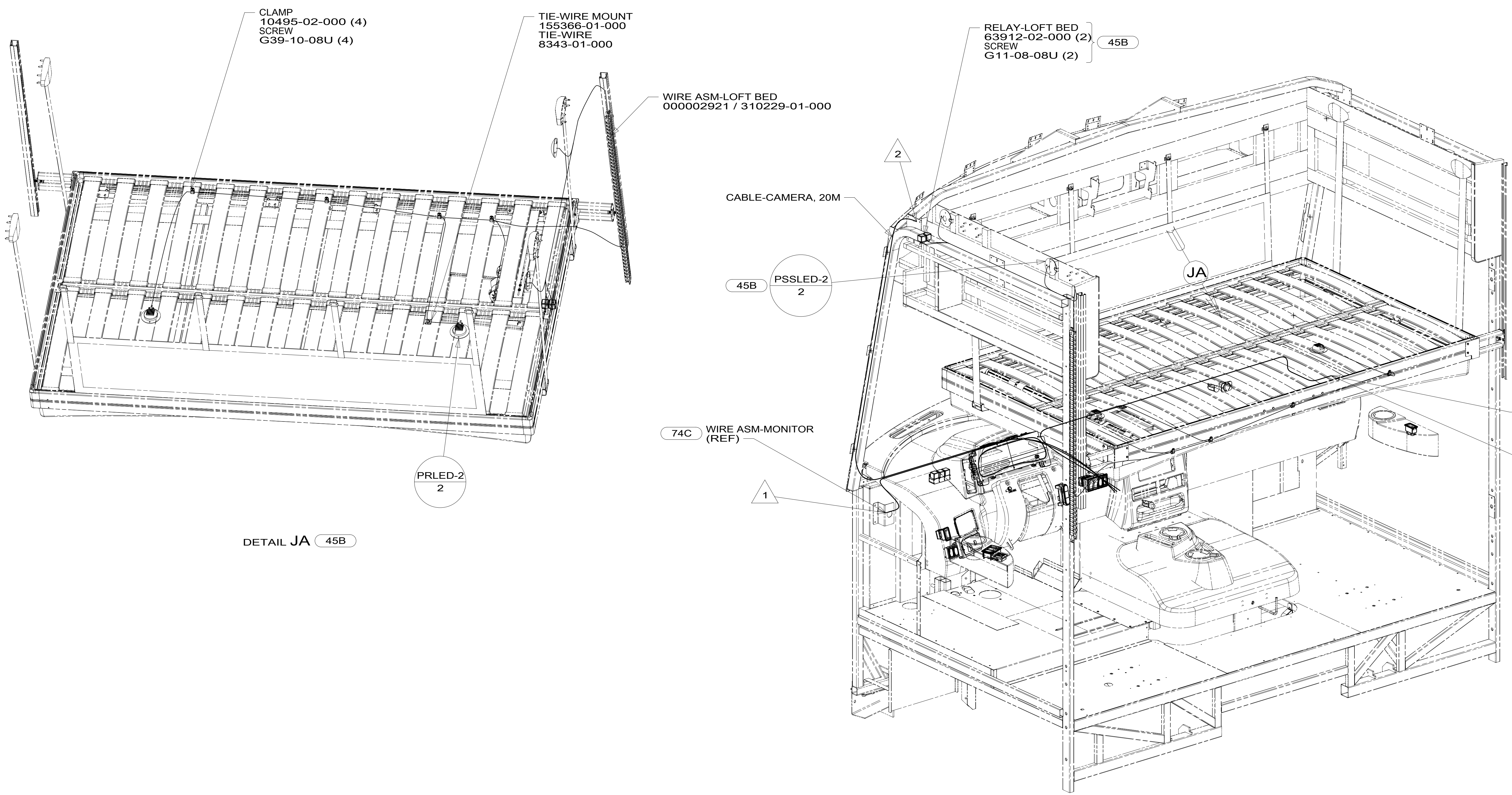

DETAIL JA 45B

- 45B LOFT BED
- 74C VIDEO CAMERA SYSTEM
- 265 CODES/STANDARDS-CSA/CMVSS
- 1B1 CODES/STANDARDS USA

NOTES:

2 RUN CABLE THRU LEFT-HAND COVE TO REAR OF UNIT. SEE SHEET 8.

1 CONNECT CAMERA THRU HOLE IN SIDEWALL, PUSH CONNECTOR BACK THRU SIDEWALL, AND SEAL HOLE.

FOR ELECTRICAL TORQUE SPECIFICATIONS SEE DWG NO. 128783-01-000

FOR ELECTRICAL CALLOUTS SEE DWG NO. 121339-01-000

DESCRIPTION:	
WIRING INSTL-FRONT END	
SHEET:	ITEM/PART NO. REV
9 OF 9	000124466 / 32393101000

8 7 6 5 4 3 2 1 29-Jan-2018