

8

7

6

5



4

3

2

1

CABLE ASM-COACH BATTERY GND (BLK)		133567-12-006
CABLE ASM-GENERATOR (GRN)		141415-42-078
CABLE ASM-GENERATOR GND (BLK)		133566-12-008
LEVELING SYSTEM POWER CABLE (BLU)	60M	141415-29-034
LEVELING SYSTEM GND CABLE (BLK)	60M	133566-12-008
CABLE ASM-STARTER (RED)		141416-32-026
CABLE ASM-CHASSIS BATTERY FUSE (RED)		141415-32-014
CABLE ASM-INVERTER (ORG)		141415-62-016
CABLE ASM-INVERTER GND (BLK)		133566-12-018
CABLE ASM-INVERTER CASE GND (GND)		136145-05-022

- 60M HYDRAULIC LEVEL JACKS-AUTO
- 265 CODES/STANDARDS-CSA/CMVSS
- 1B1 CODES/STANDARDS USA

1B1 265



COPYRIGHT 2016 WINNEBAGO INDUSTRIES, INC.

DSNR:		ALL DIMENSIONS ARE IN MILLIMETERS		
DIFFR:		MATERIAL:		
UNSPECIFIED TOLERANCES:				
WHOLE DIM (X)	: 3			
ONE-PLACE (X.X)	: 1.5			
TWO-PLACE (X.XX)	: 0.50			
ANGLE	: 1°			

REFER TO ES0018 FOR FASTENER TIGHTENING GUIDELINES	WEIGHT: (LBS)	FIRST USED:
		18 V29L

FOR ELECTRICAL TORQUE SPECIFICATIONS SEE DWG NO. 128783-01-000

FOR ELECTRICAL CALLOUTS SEE DWG NO. 121339-01-000

DESCRIPTION: **BATTERY INSTL**

SHEET: 1 OF 4	ITEM/PART NO: 000122524 / 32333301000	REV:
---------------	---------------------------------------	------

REF: 1 06-Apr-2018

8

7

6

5



4

3

2

1

06-Apr-2018

8 7 6 5 4 3 2 1

D  
C  
B  
A

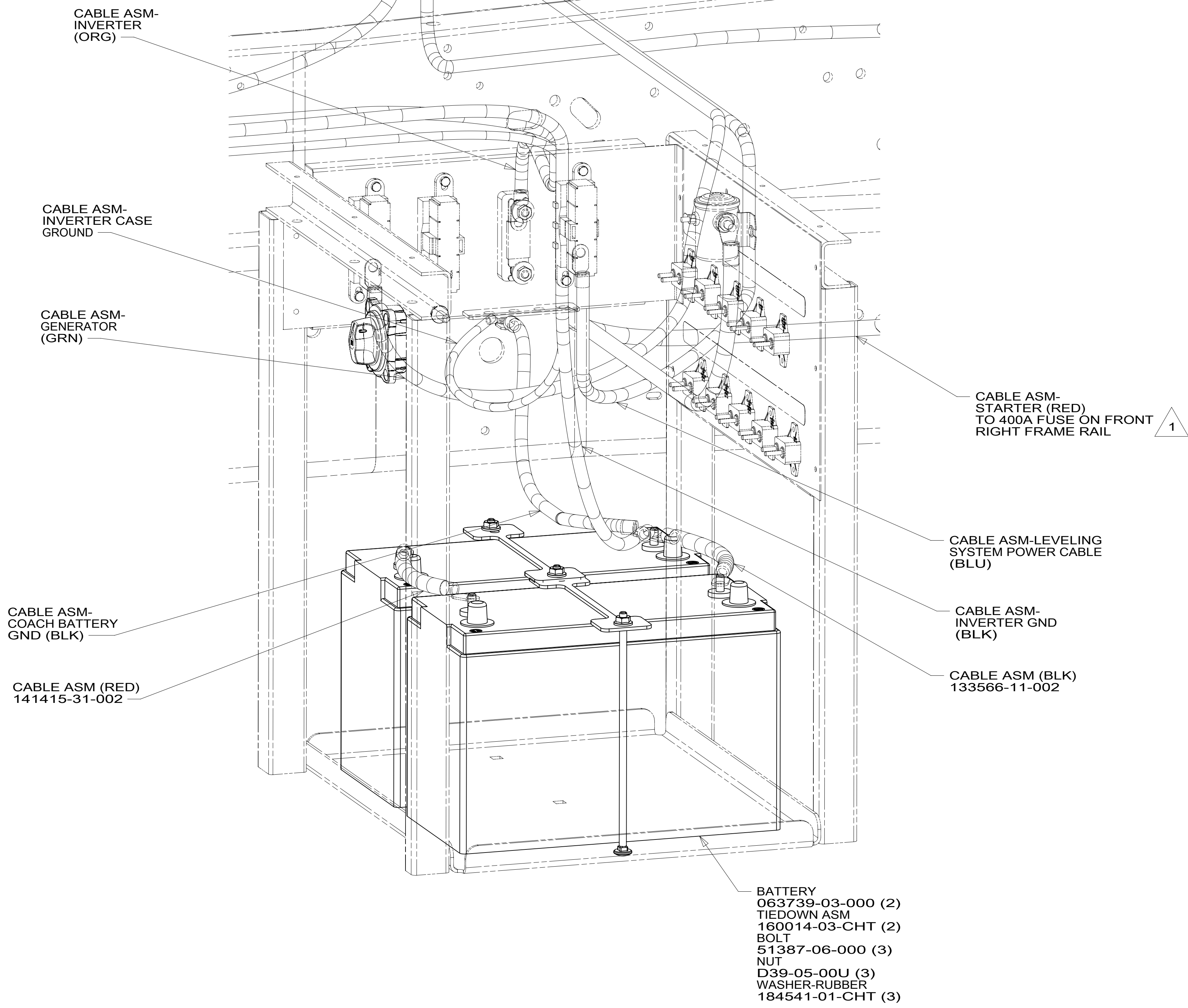

1 SEE WIRING INSTL-CHASSIS FOR ADDITIONAL INFORMATION.  
 NOTES:

FOR ELECTRICAL TORQUE SPECIFICATIONS SEE DWG NO. 128783-01-000

FOR ELECTRICAL CALLOUTS SEE DWG NO. 121339-01-000

265 CODES/STANDARDS-CSA/CMVSS  
 1B1 CODES/STANDARDS USA

DESCRIPTION:		1B1 265
<b>BATTERY INSTL</b>		
SHEET:	ITEM/PART NO.:	REV
2 OF 4	000122524 / 32333301000	

8 7 6 5 4 3 2 1 06-Apr-2018

8 7 6 5 4 3 2 1

D  
C  
B  
A

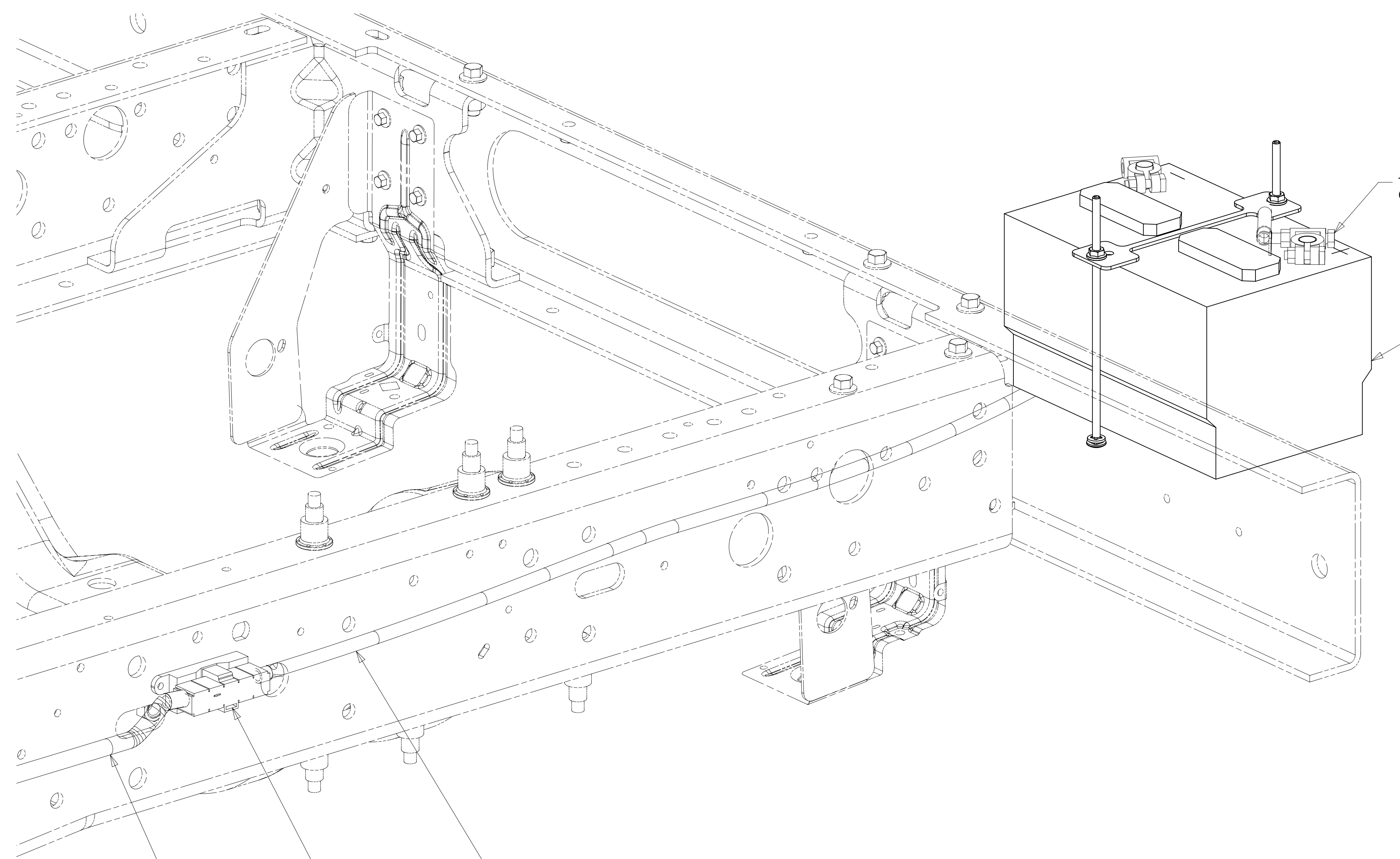

TERMINAL-BATTERY  
047441-01-000

BATTERY  
(CHASSIS SUPPLIED)  
TIEDOWN ASM  
160014-03-CHT  
BOLT  
51387-06-000 (2)  
NUT  
D39-05-00U (2)  
WASHER-RUBBER  
184541-01-CHT (2)

CABLE ASM-  
CHASSIS BATTERY  
FUSE (RED)

FUSE HOLDER  
188460-01-000  
FUSE-400A  
188461-03-000  
SCREW  
G42-04-12U (2)

CABLE ASM-  
STARTER (RED)

265 CODES/STANDARDS-CSA/CMVSS  
1B1 CODES/STANDARDS USA

FOR ELECTRICAL  
TORQUE  
SPECIFICATIONS  
SEE DWG NO.  
128783-01-000

FOR  
ELECTRICAL  
CALLOUTS  
SEE DWG NO.  
121339-01-000

DESCRIPTION:		1B1 265	
<b>BATTERY INSTL</b>			
SHEET:	ITEM/PART NO.:	REV	
3 OF 4	000122524 / 32333301000		

8 7 6 5 4 3 2 1 06-Apr-2018

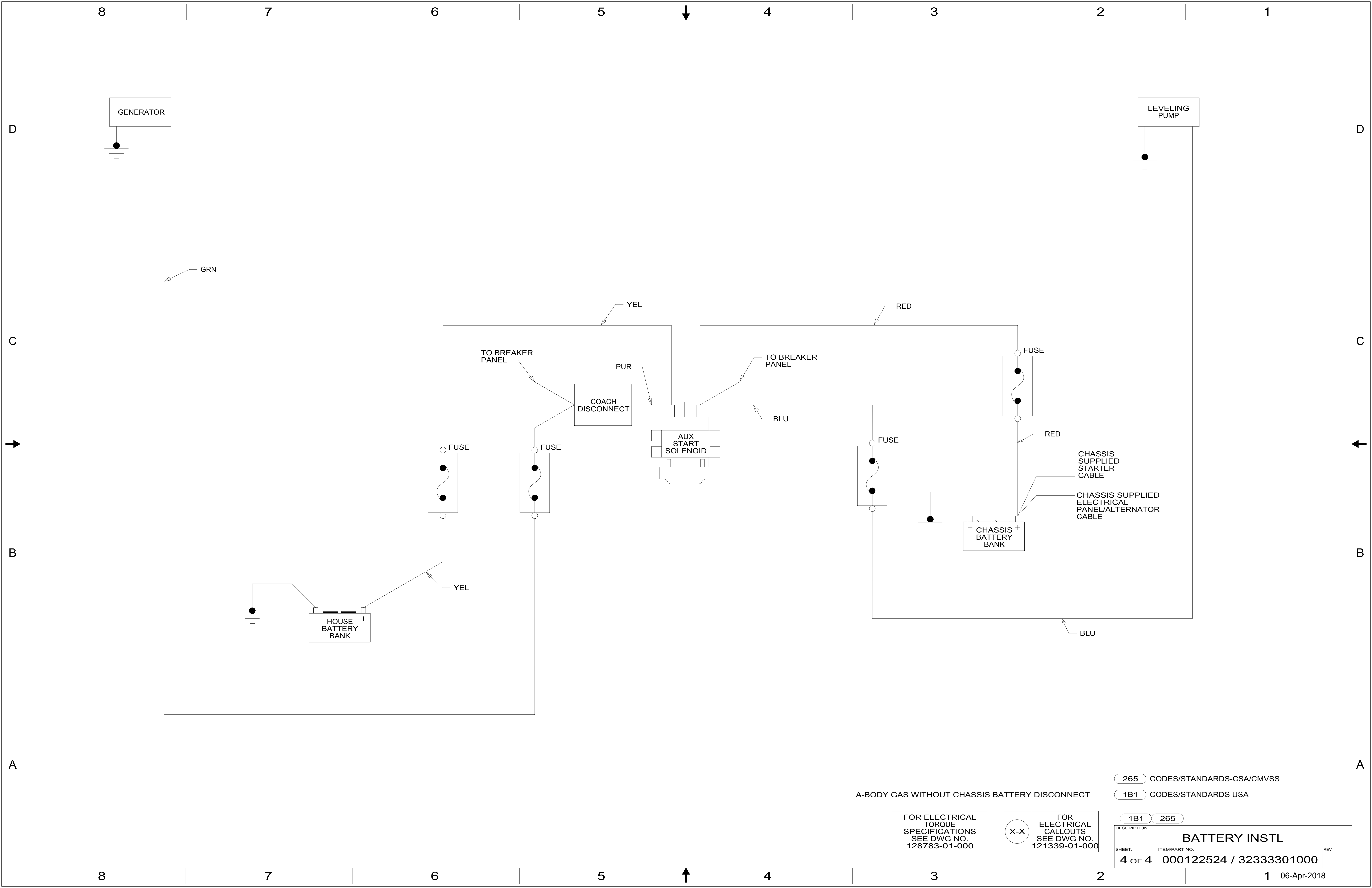

A-BODY GAS WITHOUT CHASSIS BATTERY DISCONNECT

FOR ELECTRICAL TORQUE SPECIFICATIONS SEE DWG NO. 128783-01-000

FOR ELECTRICAL CALLOUTS SEE DWG NO. 121339-01-000

- 265 CODES/STANDARDS-CSA/CMVSS
- 1B1 CODES/STANDARDS USA

DESCRIPTION:		1B1 265	
<b>BATTERY INSTL</b>			
SHEET:	ITEM/PART NO.:	REV	
4 OF 4	000122524 / 32333301000		