

CHASSIS ELECTRICAL BOX ASM
000038111 / 318725-01-000

BATTERY INSTL
000122524 / 323333-01-000

4 PIN HOUSING
TO ELECTRIC STEP

GROMMET
023942-02-000

MP, KD
TO STEP DOOR
JAMB SWITCH

GROUND
DETAIL BB

TO INVERTER

SEAL-TRIM
113452-02-000
(153 MM)

MAIN DROP
TO WIRE ASM-COACH

TO FORD SUPPLIED
TAILLAMP CIRCUITS

SEAL-TRIM
113452-02-000
(153 MM)

7 PIN HOUSING
TO TRAILER
CONNECTOR

6 PIN HOUSING
TO BACKWALL

TO GROUND BOLT

DROP TO
SLIDEOUT MOTOR

8 PIN HOUSING
TO GENERATOR

CABLE ASM (GRN)
GENERATOR

GROMMET
023942-02-000 (2)

GROMMET
023942-01-000

GROMMET
023942-02-000

DROP TO
COMPARTMENT LAMP

DROP TO SLIDEOUT
CONTROL MODULE

DROP TO
SLIDEOUT MOTOR

CABLE ASM- (BLU)
LEVELING SYSTEM

WIRE ASM-CHASSIS
000122901 / 323488-01-000

BY
TO BUSS
BAR

TO WIRE ASM-IP, MAIN
(THRU HOLE IN FLOOR)

FRONT
AXLE

DATUM

651

982

1063

697

3560

6086

TOP OF RAIL

DATUM

TO CHASSIS
BATTERY
POSITIVE POST

VIEW AA

FOR ELECTRICAL
TORQUE
SPECIFICATIONS
SEE DWG NO.
128783-01-000

FOR
ELECTRICAL
CALLOUTS
SEE DWG NO.
121339-01-000

265 CODES/STANDARDS-CSA/CMVSS

1B1 CODES/STANDARDS USA

1B1 265



COPYRIGHT 2016 WINNEBAGO INDUSTRIES, INC.

DSNR:		ALL DIMENSIONS ARE IN MILLIMETERS	
DIFFR:		MATERIAL:	
UNSPECIFIED TOLERANCES:		WEIGHT: (LBS)	FIRST USED:
WHOLE DIM (X)	: 3		18 V29L
ONE-PLACE (X.X)	: 1.5		
TWO-PLACE (X.XX)	: 0.50		
ANGLE	: 1°		
REFER TO ES0018 FOR FASTENER TIGHTENING GUIDELINES			
DESCRIPTION: WIRING INSTL-CHASSIS			
SHEET:	ITEM/PART NO.:	REV	
1 OF 2	000122520 / 32332901000		
REF:		1 06-Apr-2018	

- NOTES:
- 6 SEE WIRING INSTL-FRONT END FOR ADDITIONAL INFORMATION.
 - 5 CLAMP 83610-01-000, SCREW G11-10-16B.
 - 4. WIRE TIE 8343-04-000. FASTEN EVERY 600MM MINIMUM.
 - 3. ALL DIMENSIONS ARE FROM DATUM UNLESS OTHERWISE SPECIFIED.
 - 2 COVER SHARP EDGES WHERE WIRE CROSSES FRAME RAILS.
 - 1 SEE BATTERY INSTL FOR ADDITIONAL INFORMATION.

8 7 6 5 4 3 2 1

D
C
B
A

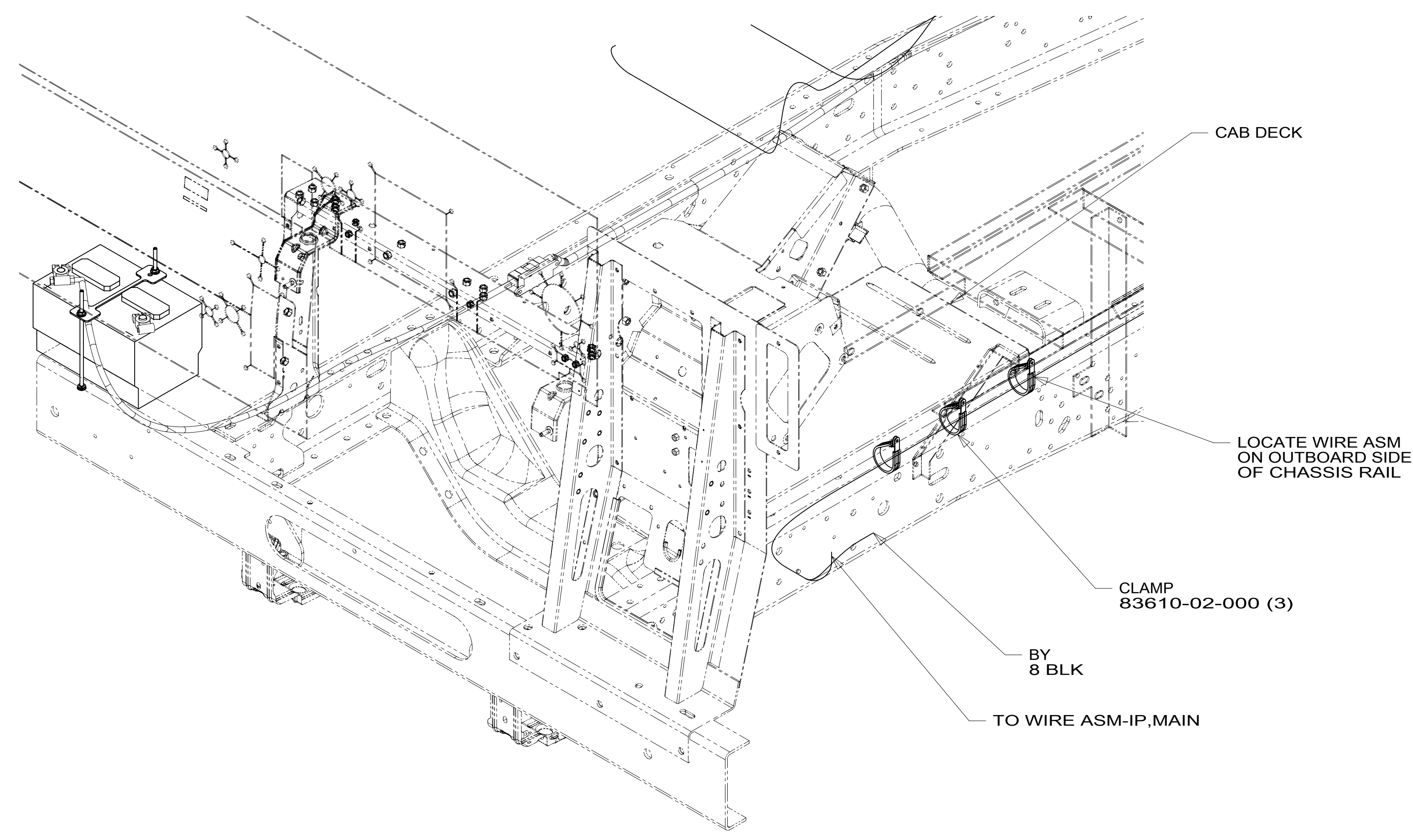

VIEW BA

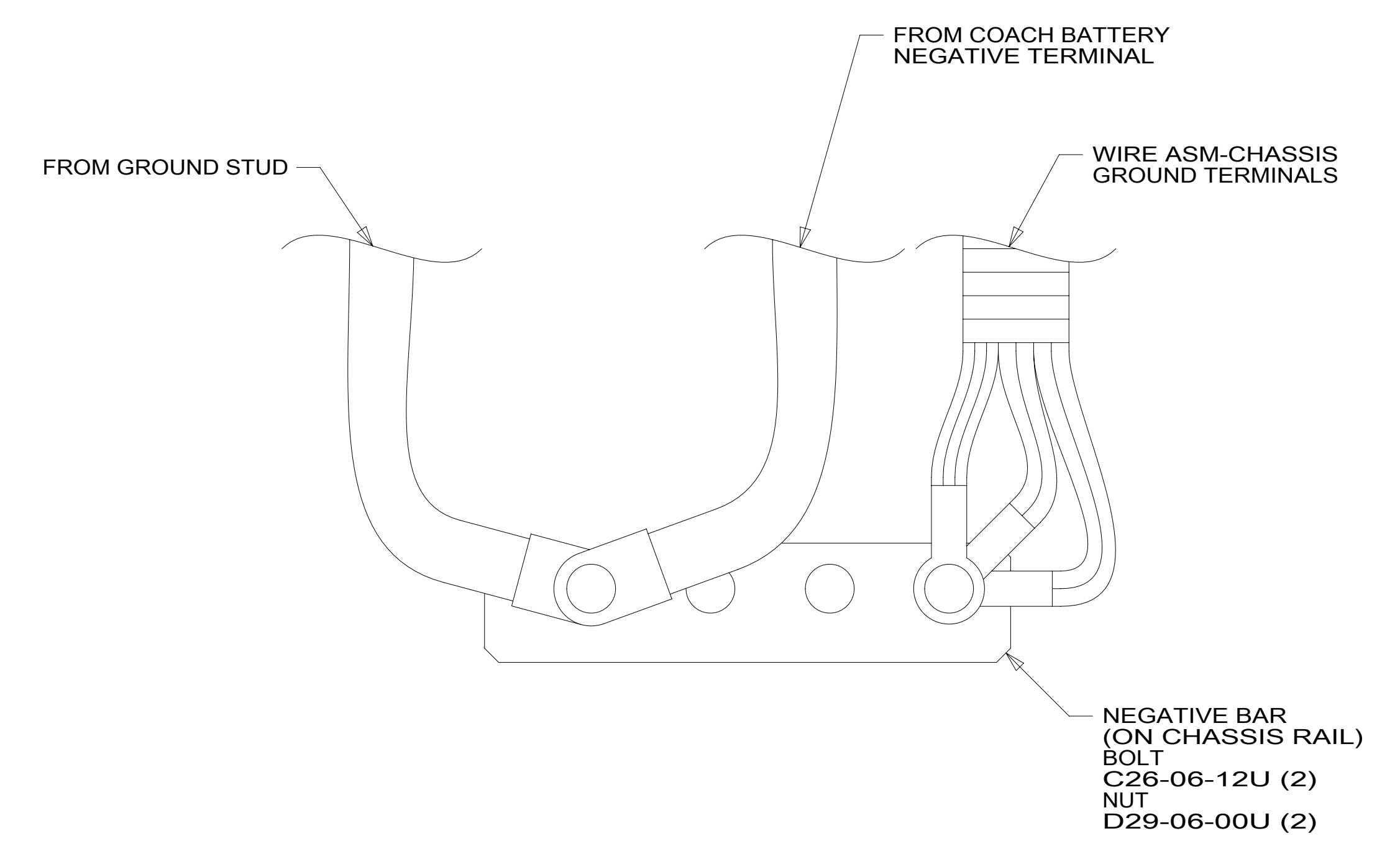

DETAIL BB

NOTES:
1. CUT OFF EXCESS END OF WIRE TIE.

FOR ELECTRICAL TORQUE SPECIFICATIONS SEE DWG NO. 128783-01-000

FOR ELECTRICAL CALLOUTS SEE DWG NO. 121339-01-000

265 CODES/STANDARDS-CSA/CMVSS
1B1 CODES/STANDARDS USA

DESCRIPTION: WIRING INSTL-CHASSIS	
SHEET: 2 OF 2	ITEM/PART NO: 000122520 / 32332901000
REV	

8 7 6 5 4 3 2 1 06-Apr-2018