

- 4 WIRE IS PART OF WIRE ASM-CHASSIS. ROUTE WIRES ABOVE HOLDING TANKS TO THE SLIDEOUT CONTROL MODULE.
- 3 WIRE PASSES THROUGH FLOOR IN THIS AREA.
2. ROUTE TANK SENSOR WIRES SO THEY DO NOT PASS OVER SENSORS. USE WIRE TIE MOUNT 155366-01-000 AND WIRE TIE 8343-01-000 AS NEEDED. TANK SURFACE MUST BE CLEANED USING ISOPROPYL ALCOHOL AND PRIMED WITH PRIMER 94.
1. AT MINIMUM ALL WIRES TO BE SUPPORTED AND SECURED PER CODE REQUIREMENTS. USE CLAMP 10495 OR 10497 OR WIRE TIE 8343 OR 108046 AND SCREW G67-XX-XXX OR G56-XX-XXX AS APPROPRIATE FOR INSTALLATION.

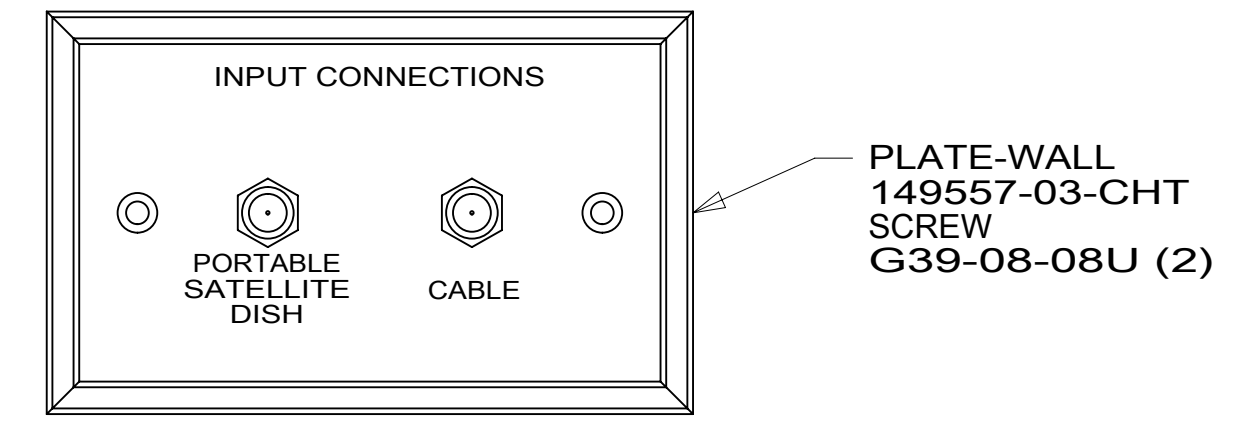

VIEW AA

FOR ELECTRICAL TORQUE SPECIFICATIONS SEE DWG NO. 128783-01-000

FOR ELECTRICAL CALLOUTS SEE DWG NO. 121339-01-000

- 299 ENTERTAINMENT CENTER EXT. W/O
- 265 CODES/STANDARDS-CSA/CMVSS
- 1B1 CODES/STANDARDS USA

WINNEBAGO COPYRIGHT 2016 WINNEBAGO INDUSTRIES, INC.	
DSNR:	ALL DIMENSIONS ARE IN MILLIMETERS
DFTFR:	
UNSPECIFIED TOLERANCES:	MATERIAL:
WHOLE DIM (X) : 3	
ONE-PLACE (X.X) : 1.5	
TWO-PLACE (X.XX) : 0.50	
ANGLE : 1°	
REFER TO ES0018 FOR FASTENER TIGHTENING GUIDELINES	WEIGHT: (LBS) FIRST USED: 18 L38W
DESCRIPTION: WIRING INSTL-BODY, 12V	
SHEET: 1 OF 8	ITEM/PART NO.: 000119411 / 32256301000
REF: 1 07-Nov-2018	

8 7 6 5 4 3 2 1

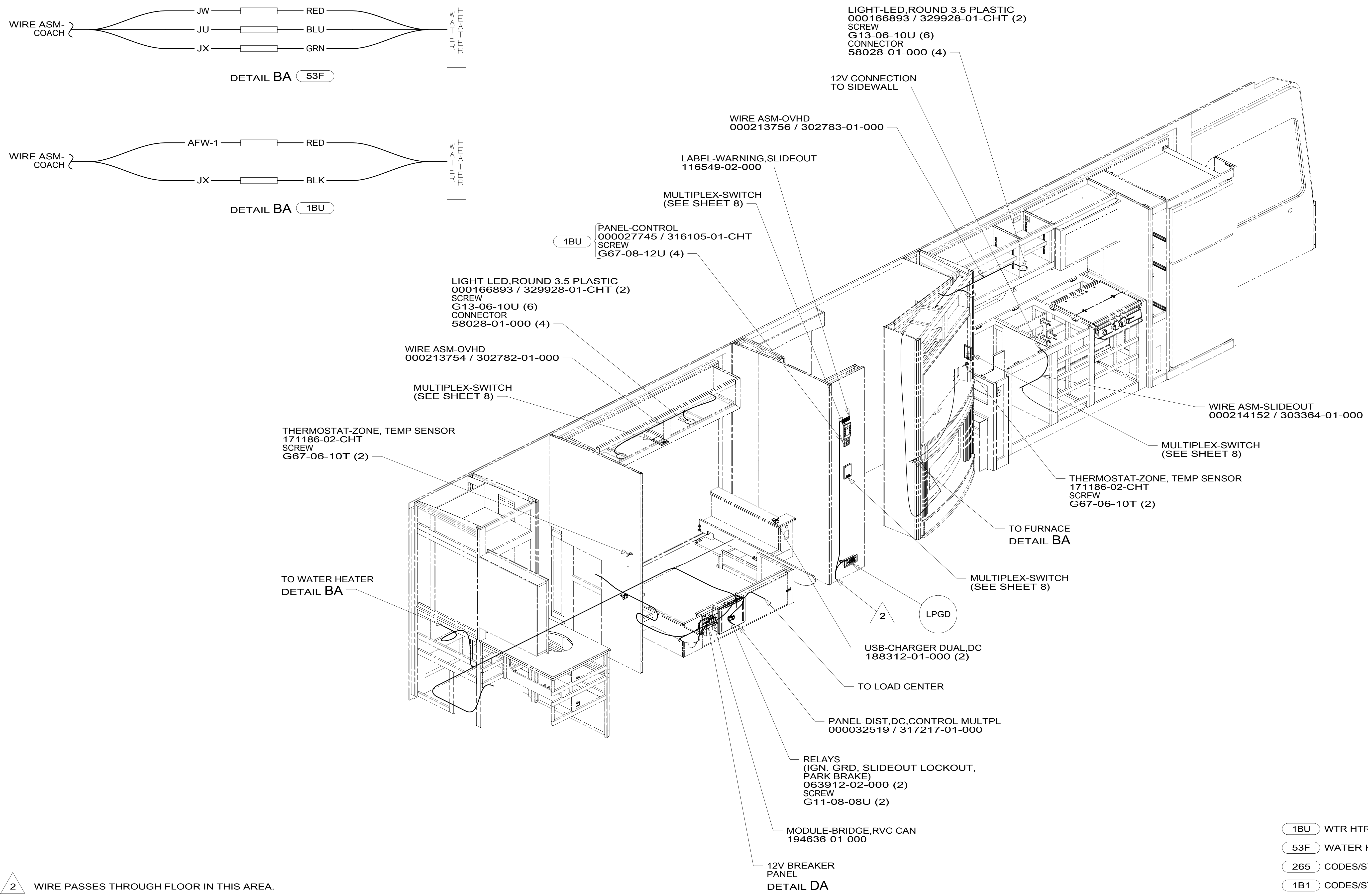
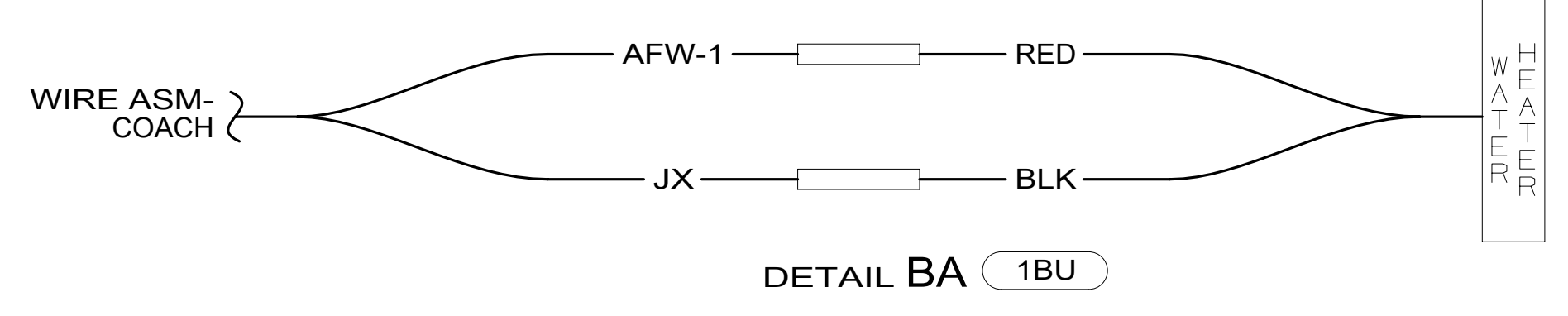
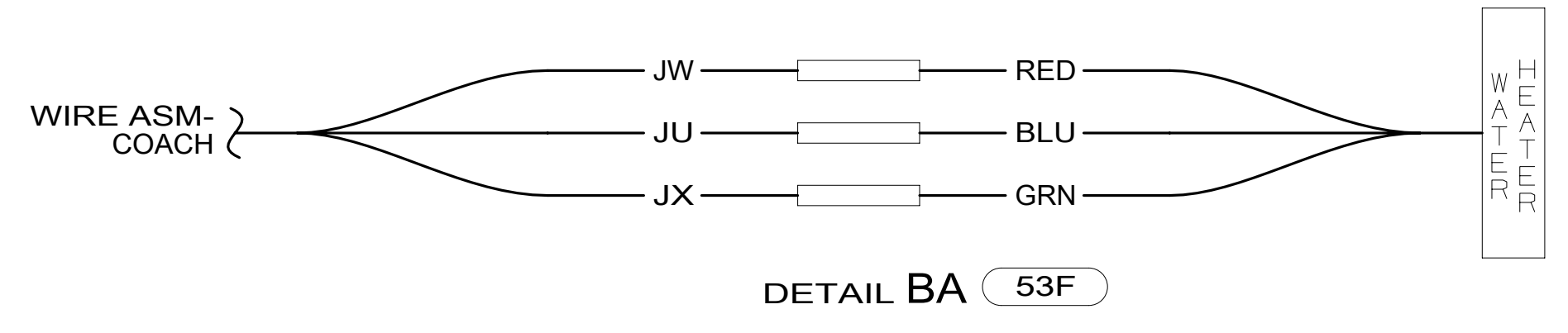

2 WIRE PASSES THROUGH FLOOR IN THIS AREA.

1. AT MINIMUM ALL WIRES TO BE SUPPORTED AND SECURED PER CODE REQUIREMENTS. USE CLAMP 10495 OR 10497 OR WIRE TIE 8343 OR 108046 AND SCREW G67-XX-XXX OR G56-XX-XXX AS APPROPRIATE FOR INSTALLATION.

NOTES:

FOR ELECTRICAL TORQUE SPECIFICATIONS SEE DWG NO. 128783-01-000

FOR ELECTRICAL CALLOUTS SEE DWG NO. 121339-01-000

- 1BU WTR HTR TKLS W/RECIRCUL PUMP
- 53F WATER HEATER-ELEC. IGNITION
- 265 CODES/STANDARDS-CSA/CMVSS
- 1B1 CODES/STANDARDS USA

DESCRIPTION:	
WIRING INSTL-BODY, 12V	
SHEET:	ITEM/PART NO:
2 OF 8	000119411 / 32256301000
REV	

8 7 6 5 4 3 2 1 07-Nov-2018

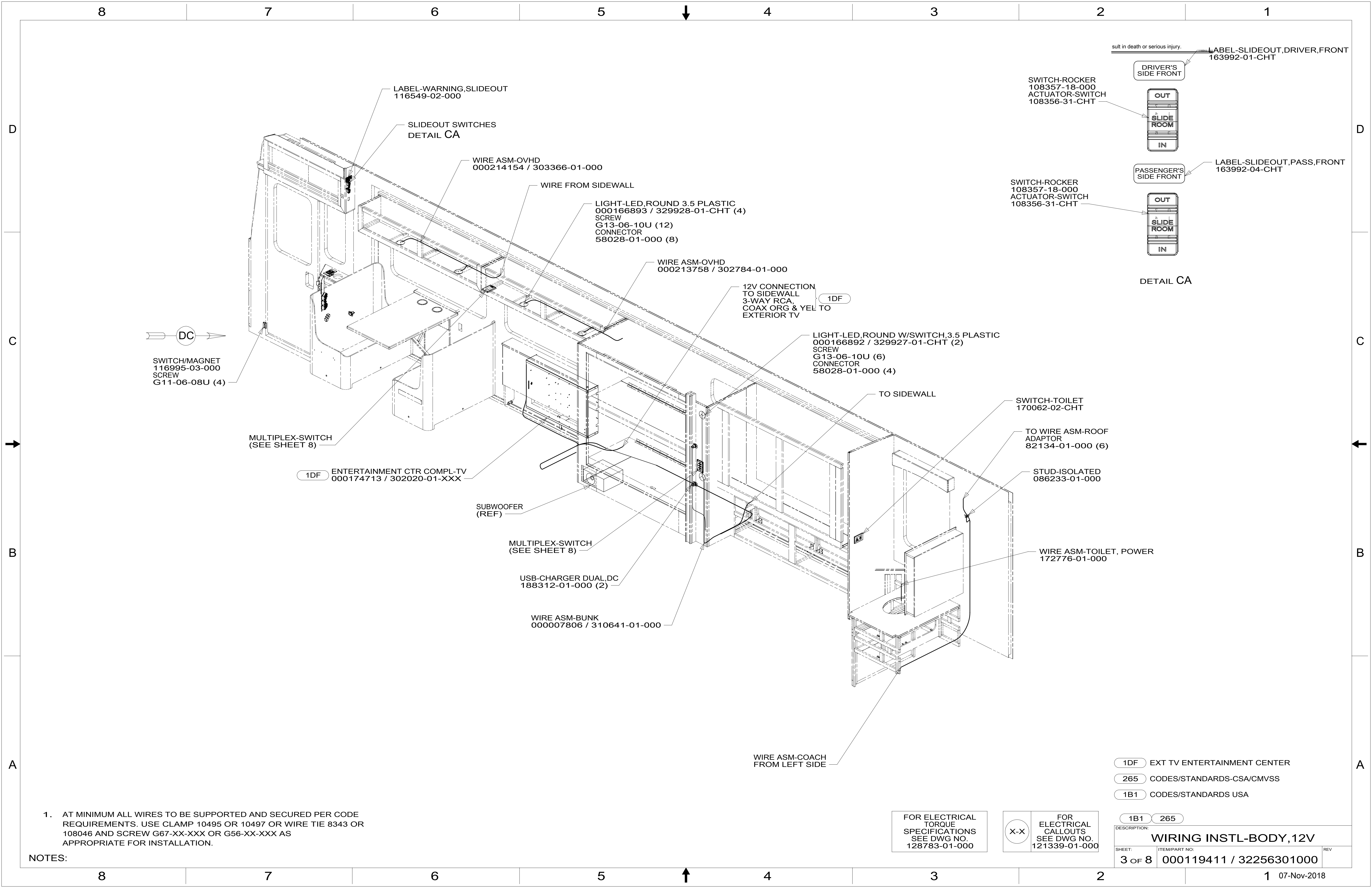

DC →
 SWITCH/MAGNET
 116995-03-000
 SCREW
 G11-06-08U (4)

LABEL-WARNING,SLIDEOUT
 116549-02-000
 SLIDEOUT SWITCHES
 DETAIL CA
 WIRE ASM-OVHD
 000214154 / 303366-01-000
 WIRE FROM SIDEWALL

LIGHT-LED,ROUND 3.5 PLASTIC
 000166893 / 329928-01-CHT (4)
 SCREW
 G13-06-10U (12)
 CONNECTOR
 58028-01-000 (8)

WIRE ASM-OVHD
 000213758 / 302784-01-000

12V CONNECTION
 TO SIDEWALL
 3-WAY RCA,
 COAX ORG & YEL TO
 EXTERIOR TV
 1DF

LIGHT-LED,ROUND W/SWITCH,3.5 PLASTIC
 000166892 / 329927-01-CHT (2)
 SCREW
 G13-06-10U (6)
 CONNECTOR
 58028-01-000 (4)

MULTIPLEX-SWITCH
 (SEE SHEET 8)

1DF ENTERTAINMENT CTR COMPL-TV
 000174713 / 302020-01-XXX

SUBWOOFER
 (REF)

MULTIPLEX-SWITCH
 (SEE SHEET 8)

USB-CHARGER DUAL,DC
 188312-01-000 (2)

WIRE ASM-BUNK
 000007806 / 310641-01-000

WIRE ASM-COACH
 FROM LEFT SIDE

TO SIDEWALL

SWITCH-TOILET
 170062-02-CHT

TO WIRE ASM-ROOF
 ADAPTOR
 82134-01-000 (6)

STUD-ISOLATED
 086233-01-000

WIRE ASM-TOILET, POWER
 172776-01-000

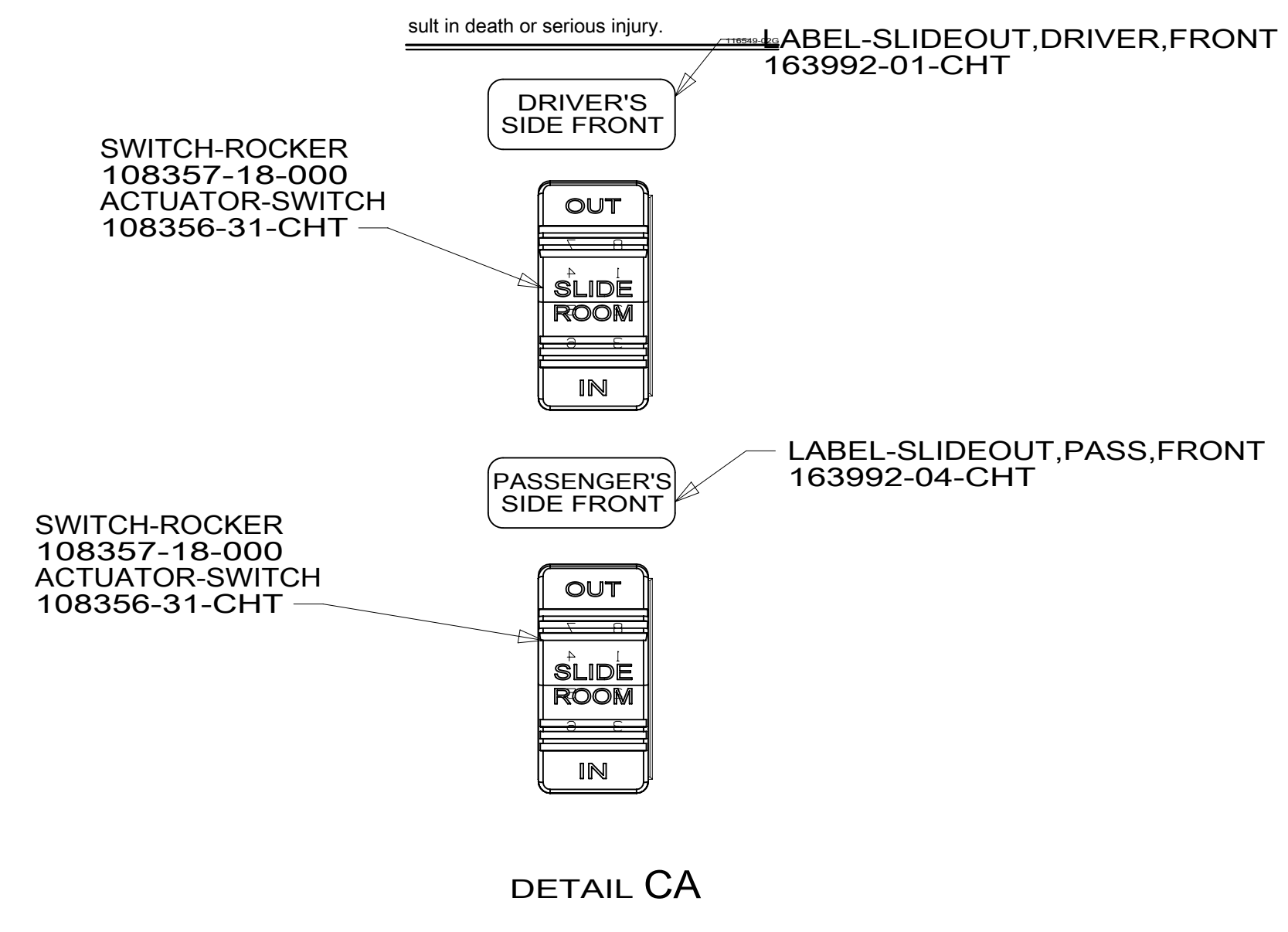

NOTES:
 1. AT MINIMUM ALL WIRES TO BE SUPPORTED AND SECURED PER CODE REQUIREMENTS. USE CLAMP 10495 OR 10497 OR WIRE TIE 8343 OR 108046 AND SCREW G67-XX-XXX OR G56-XX-XXX AS APPROPRIATE FOR INSTALLATION.

FOR ELECTRICAL
 TORQUE
 SPECIFICATIONS
 SEE DWG NO.
 128783-01-000

FOR ELECTRICAL
 CALLOUTS
 SEE DWG NO.
 121339-01-000

- 1DF EXT TV ENTERTAINMENT CENTER
- 265 CODES/STANDARDS-CSA/CMVSS
- 1B1 CODES/STANDARDS USA

DESCRIPTION: WIRING INSTL-BODY, 12V		
SHEET: 3 OF 8	ITEM/PART NO: 000119411 / 32256301000	REV

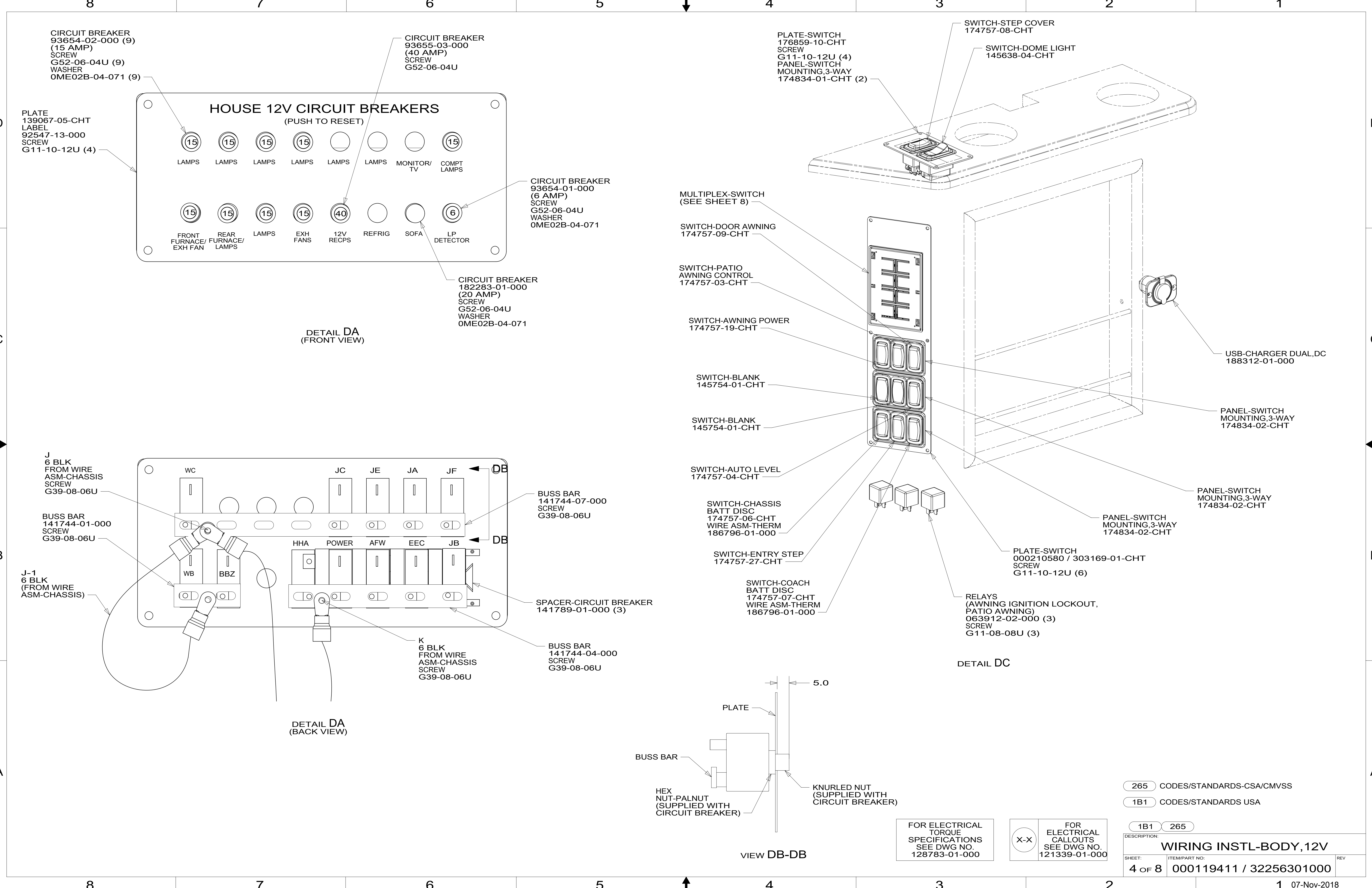

CIRCUIT BREAKER
93654-02-000 (9)
(15 AMP)
SCREW
G52-06-04U (9)
WASHER
OME02B-04-071 (9)

CIRCUIT BREAKER
93655-03-000
(40 AMP)
SCREW
G52-06-04U

PLATE-SWITCH
176859-10-CHT
SCREW
G11-10-12U (4)
PANEL-SWITCH
MOUNTING,3-WAY
174834-01-CHT (2)

SWITCH-STEP COVER
174757-08-CHT

SWITCH-DOME LIGHT
145638-04-CHT

PLATE
139067-05-CHT
LABEL
92547-13-000
SCREW
G11-10-12U (4)

HOUSE 12V CIRCUIT BREAKERS
(PUSH TO RESET)

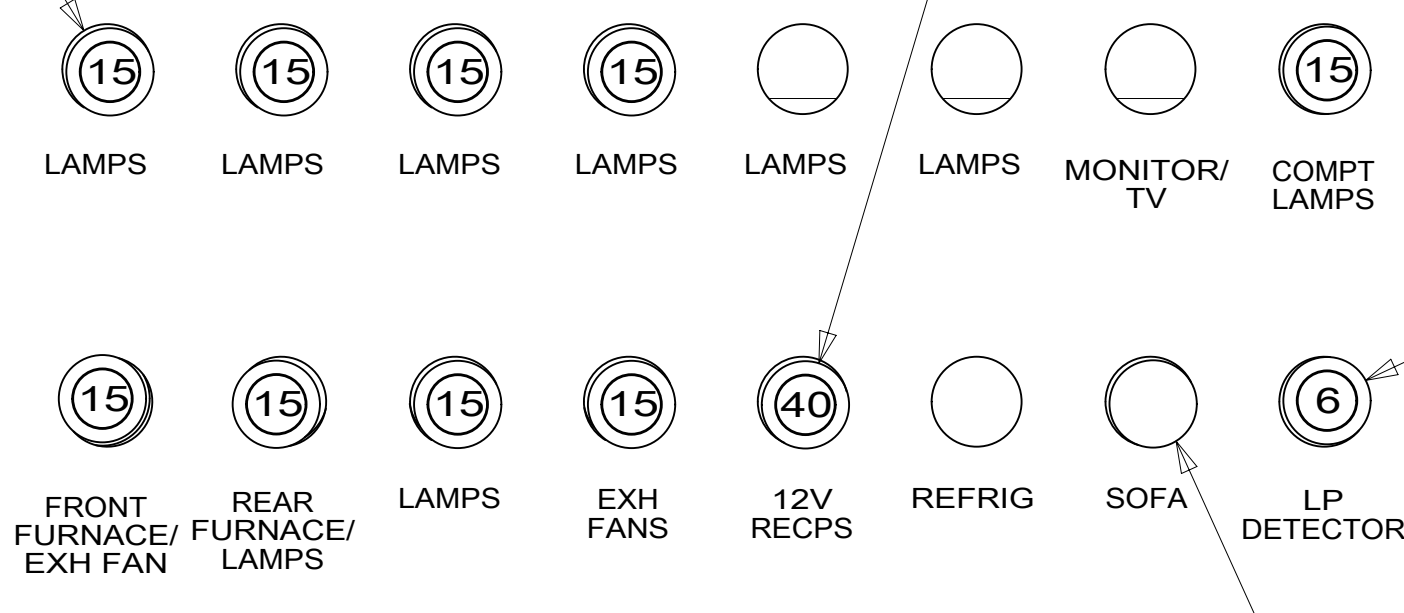

CIRCUIT BREAKER
93654-01-000
(6 AMP)
SCREW
G52-06-04U
WASHER
OME02B-04-071

CIRCUIT BREAKER
182283-01-000
(20 AMP)
SCREW
G52-06-04U
WASHER
OME02B-04-071

DETAIL DA
(FRONT VIEW)

MULTIPLEX-SWITCH
(SEE SHEET 8)

SWITCH-DOOR AWNING
174757-09-CHT

SWITCH-PATIO
AWNING CONTROL
174757-03-CHT

SWITCH-AWNING POWER
174757-19-CHT

SWITCH-BLANK
145754-01-CHT

SWITCH-BLANK
145754-01-CHT

SWITCH-AUTO LEVEL
174757-04-CHT

SWITCH-CHASSIS
BATT DISC
174757-06-CHT
WIRE ASM-THERM
186796-01-000

SWITCH-ENTRY STEP
174757-27-CHT

SWITCH-COACH
BATT DISC
174757-07-CHT
WIRE ASM-THERM
186796-01-000

USB-CHARGER DUAL,DC
188312-01-000

PANEL-SWITCH
MOUNTING,3-WAY
174834-02-CHT

PANEL-SWITCH
MOUNTING,3-WAY
174834-02-CHT

PLATE-SWITCH
000210580 / 303169-01-CHT
SCREW
G11-10-12U (6)

RELAYS
(AWNING IGNITION LOCKOUT,
PATIO AWNING)
063912-02-000 (3)
SCREW
G11-08-08U (3)

DETAIL DC

J
6 BLK
FROM WIRE
ASM-CHASSIS
SCREW
G39-08-06U

BUSS BAR
141744-01-000
SCREW
G39-08-06U

J-1
6 BLK
(FROM WIRE
ASM-CHASSIS)

BUSS BAR
141744-07-000
SCREW
G39-08-06U

SPACER-CIRCUIT BREAKER
141789-01-000 (3)

K
6 BLK
FROM WIRE
ASM-CHASSIS
SCREW
G39-08-06U

BUSS BAR
141744-04-000
SCREW
G39-08-06U

DETAIL DA
(BACK VIEW)

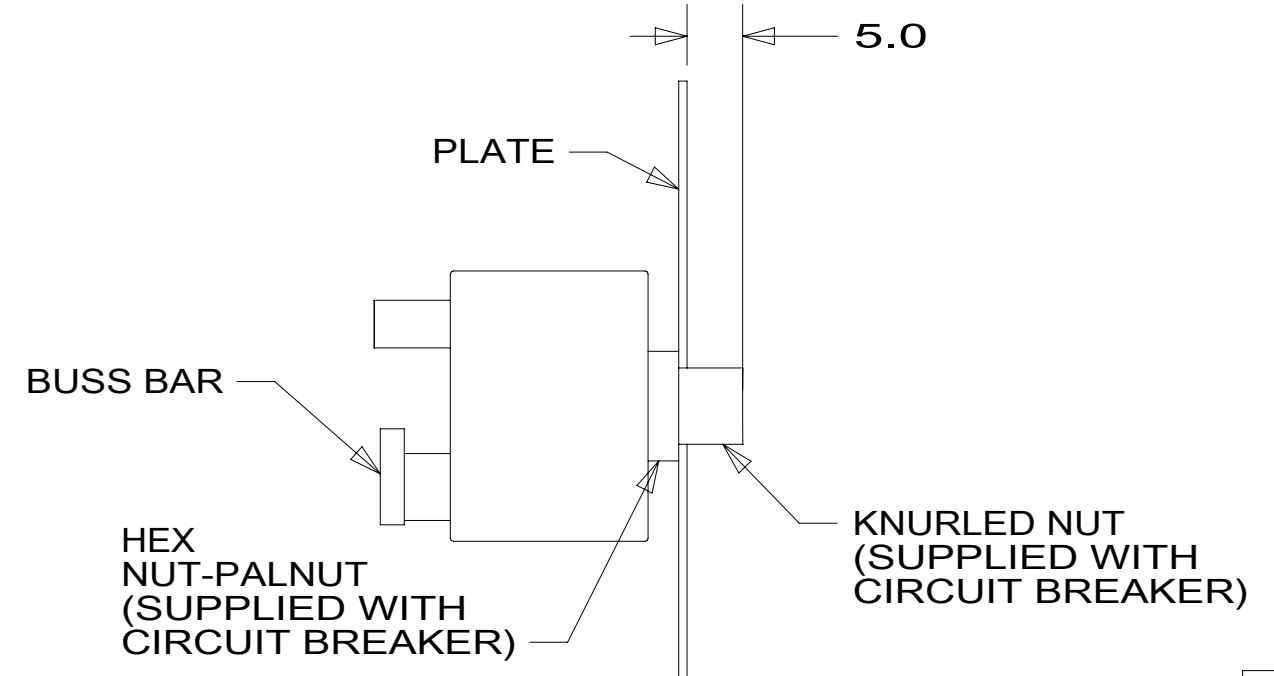

VIEW DB-DB

FOR ELECTRICAL
TORQUE
SPECIFICATIONS
SEE DWG NO.
128783-01-000

FOR ELECTRICAL
CALLOUTS
SEE DWG NO.
121339-01-000

265 CODES/STANDARDS-CSA/CMVSS
1B1 CODES/STANDARDS USA

1B1 265

DESCRIPTION: WIRING INSTL-BODY, 12V		
SHEET: 4 OF 8	ITEM/PART NO: 000119411 / 32256301000	REV

8 7 6 5 4 3 2 1

D
C
B
A

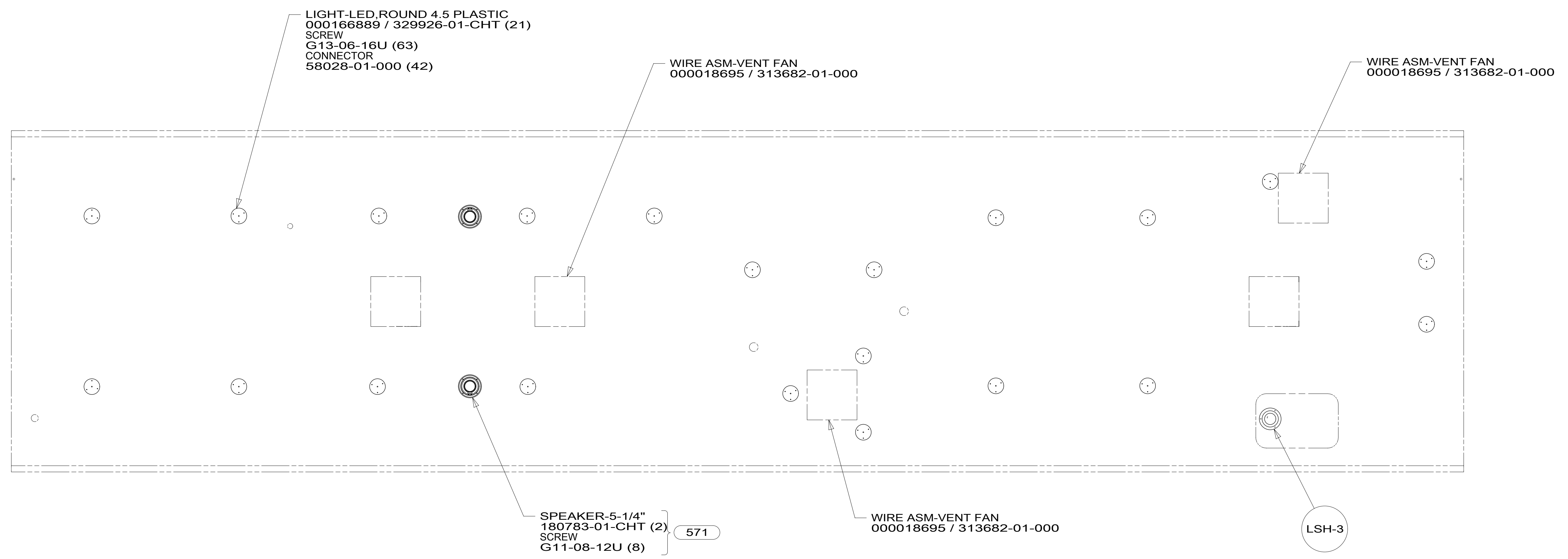

- 571 RADIO SPEAKERS
- 265 CODES/STANDARDS-CSA/CMVSS
- 1B1 CODES/STANDARDS USA

FOR ELECTRICAL TORQUE SPECIFICATIONS SEE DWG NO. 128783-01-000

FOR ELECTRICAL CALLOUTS SEE DWG NO. 121339-01-000

DESCRIPTION:	
WIRING INSTL-BODY, 12V	
SHEET:	ITEM/PART NO. REV
5 OF 8	000119411 / 32256301000

8 7 6 5 4 3 2 1 07-Nov-2018

8 7 6 5 4 3 2 1

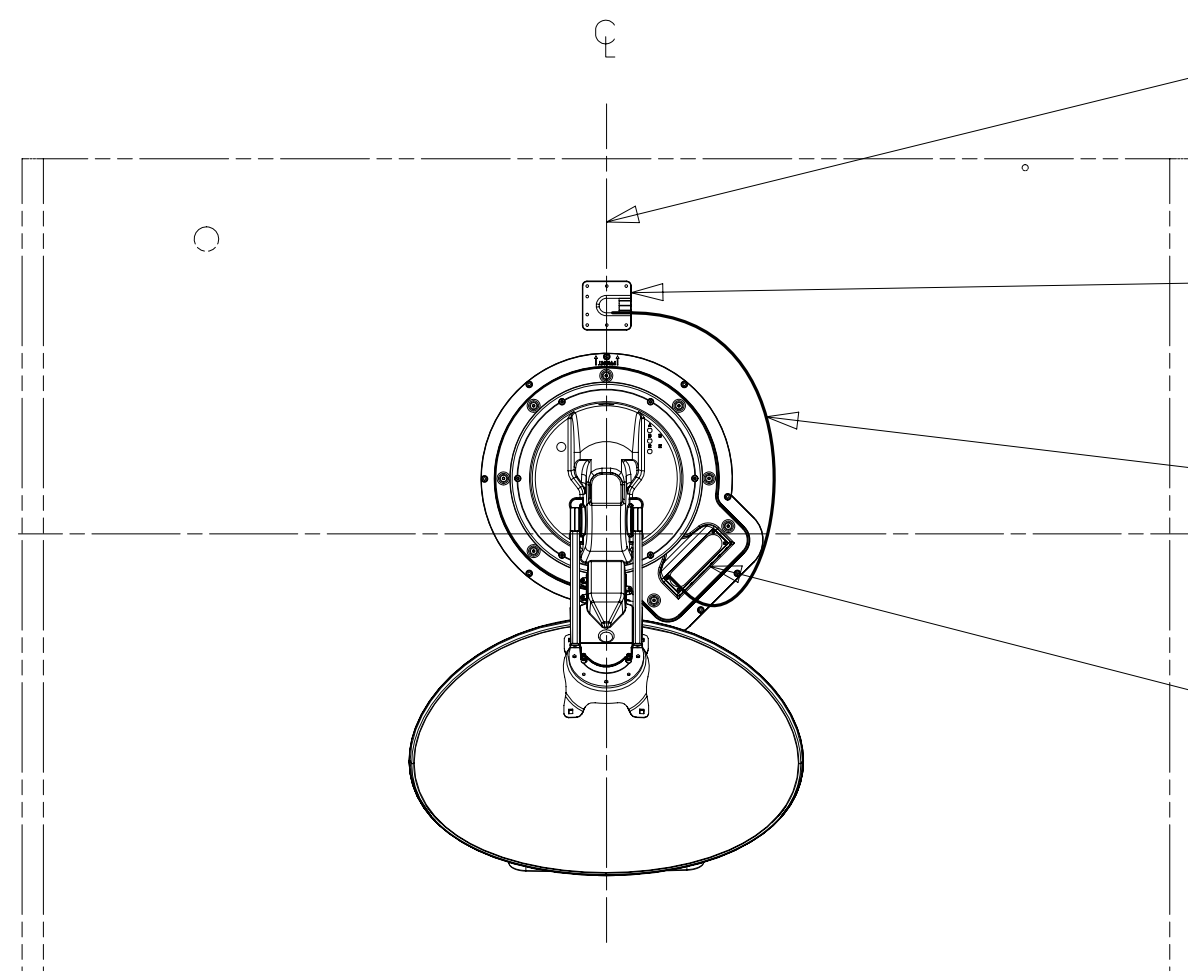

THE SATELLITE DISH AND WIRE CONNECTIONS ARE TO BE PLACED ON THE CENTERLINE OF THE MOTORHOME FACING FORWARD.

SEPARATE CABLES AND INSTALL WIRE COVER OVER HOLE IN ROOF ASM WITH CABLES EXITING ON PASSENGERS SIDE.

WHEN APPLYING ROOF SEALANT TO SATELLITE DISH, PLACE ROOF SEALANT HERE (APPROX. 75MM WIDE) AND PUSH THE CABLES INTO THE SEALANT TO STABILIZE THEM.

CONNECT CABLE ASM-COAX FROM ROOF ASM TO COAX CABLES ON SATELLITE DISH AND CONNECT 10' CABLE-DATA FROM ROOF ASM TO DATA CABLE FROM SATELLITE DISH AND PLACE ALL CONNECTIONS BACK INTO ROOF ASM.

DETAIL GA

1 783 DA-4
DETAIL GA

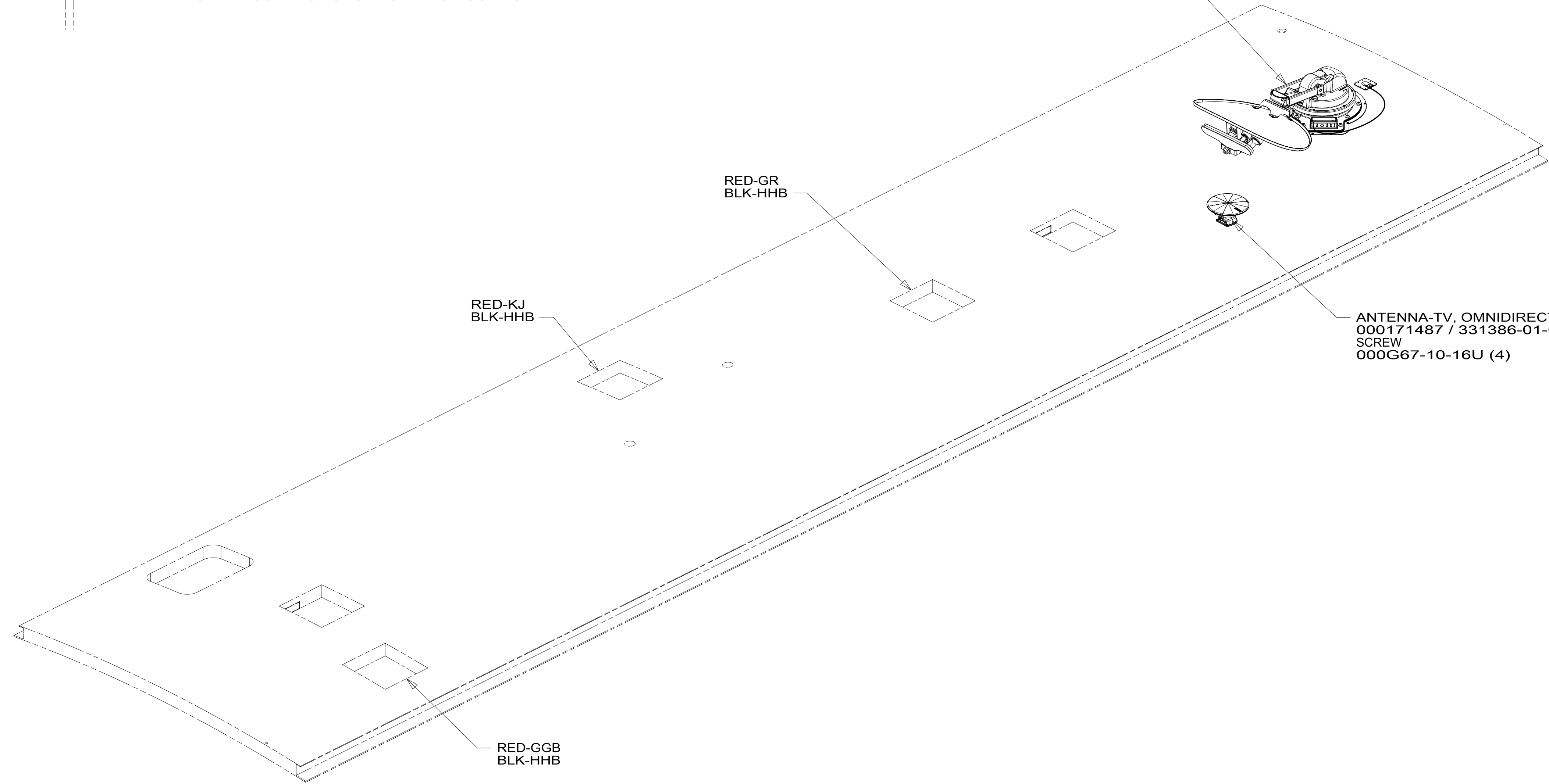

ANTENNA-TV, OMNIDIRECTIONAL
000171487 / 331386-01-CHT
SCREW
000G67-10-16U (4)

1 193

D
C
B
A

D
C
B
A

1 SEE MANUFACTURER'S INSTALLATION FOR ADDITIONAL INFORMATION.

NOTES:

FOR ELECTRICAL TORQUE SPECIFICATIONS SEE DWG NO. 128783-01-000

FOR ELECTRICAL CALLOUTS SEE DWG NO. 121339-01-000

- 783 SATELLITE HD TV SYSTEM AUTOC
- 193 TV ANTENNA-AMPLIFIED SYSTEM
- 265 CODES/STANDARDS-CSA/CMVSS
- 1B1 CODES/STANDARDS USA

1B1 265

DESCRIPTION: WIRING INSTL-BODY, 12V

SHEET: 6 OF 8 ITEM/PART NO: 000119411 / 32256301000 REV

8 7 6 5 4 3 2 1 07-Nov-2018

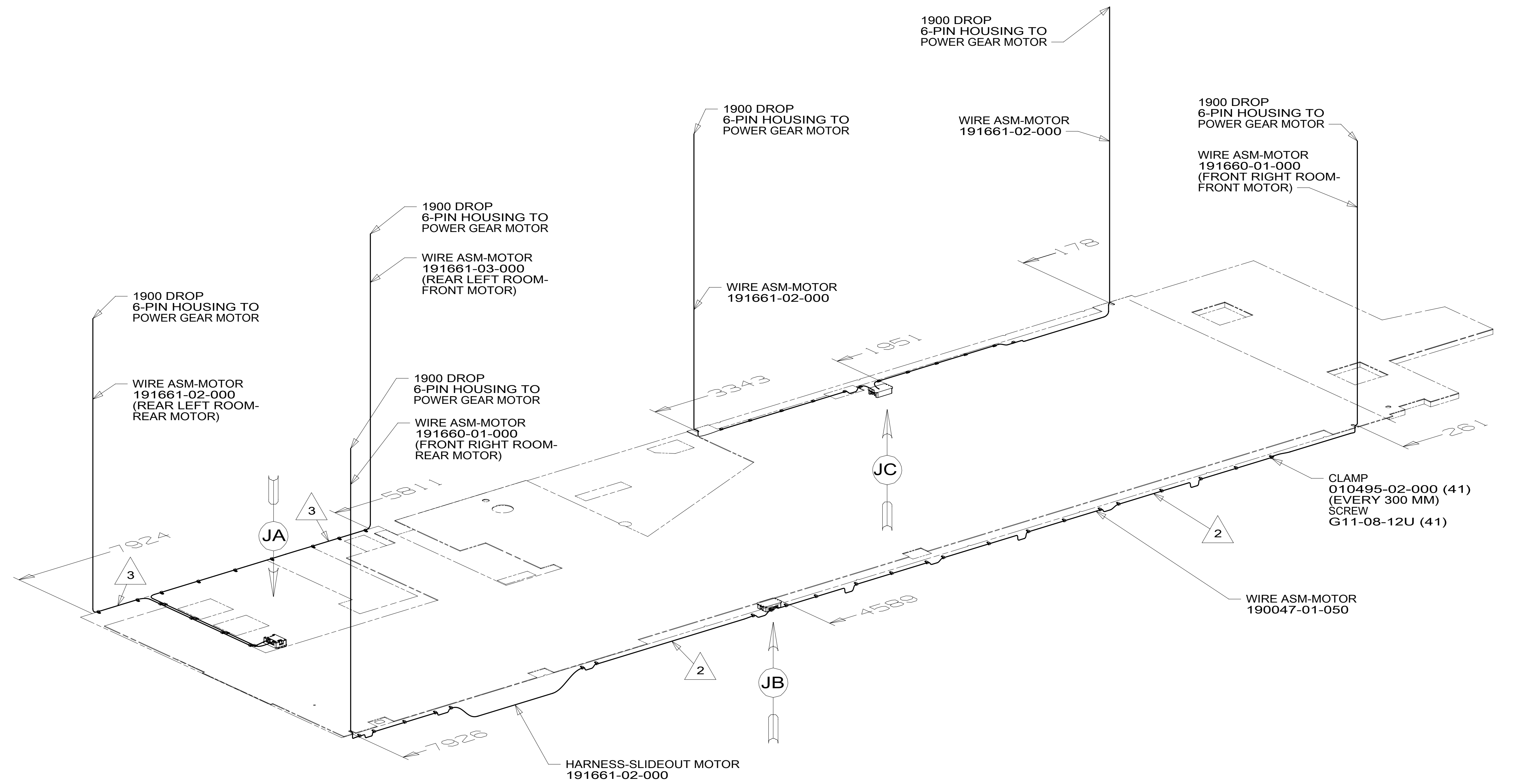
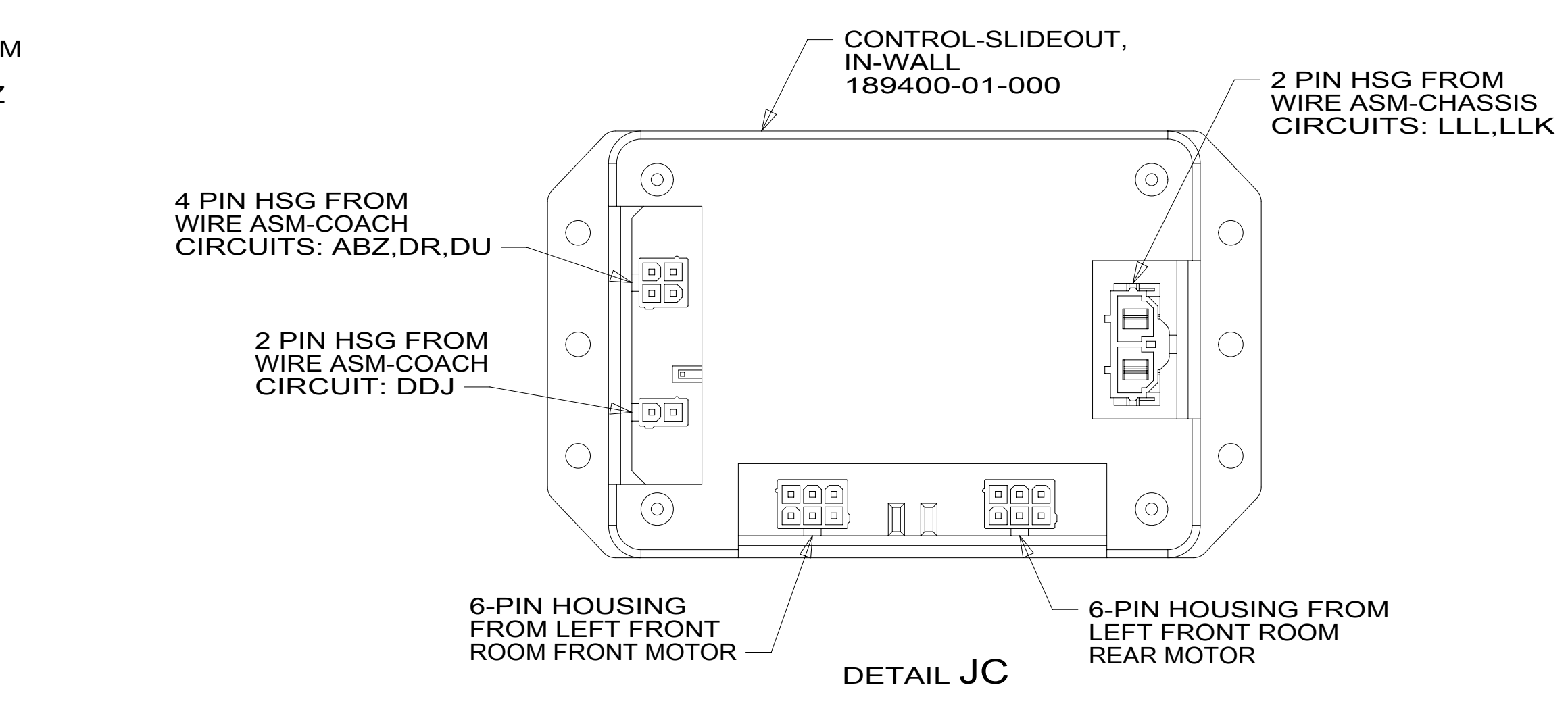
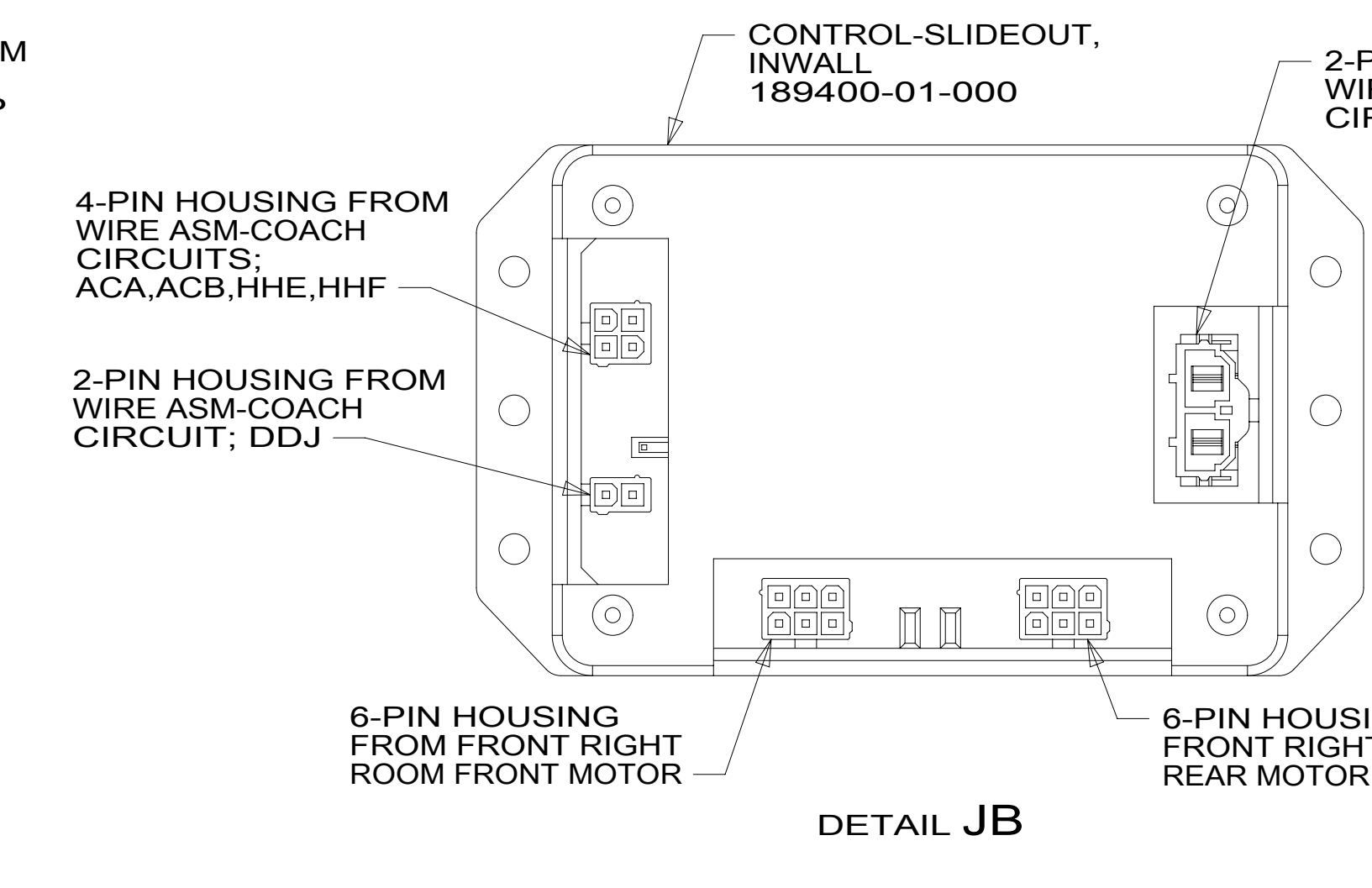
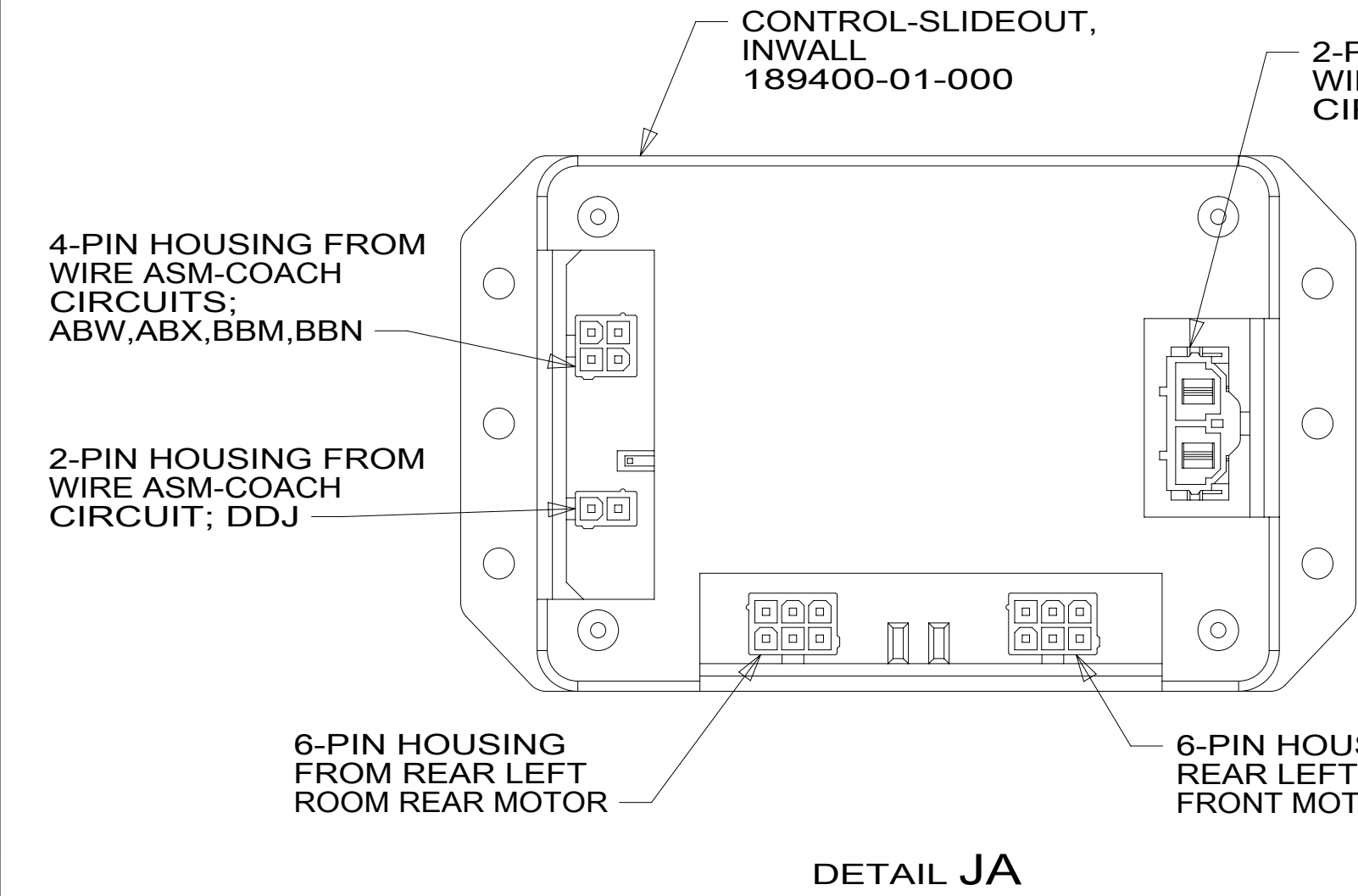
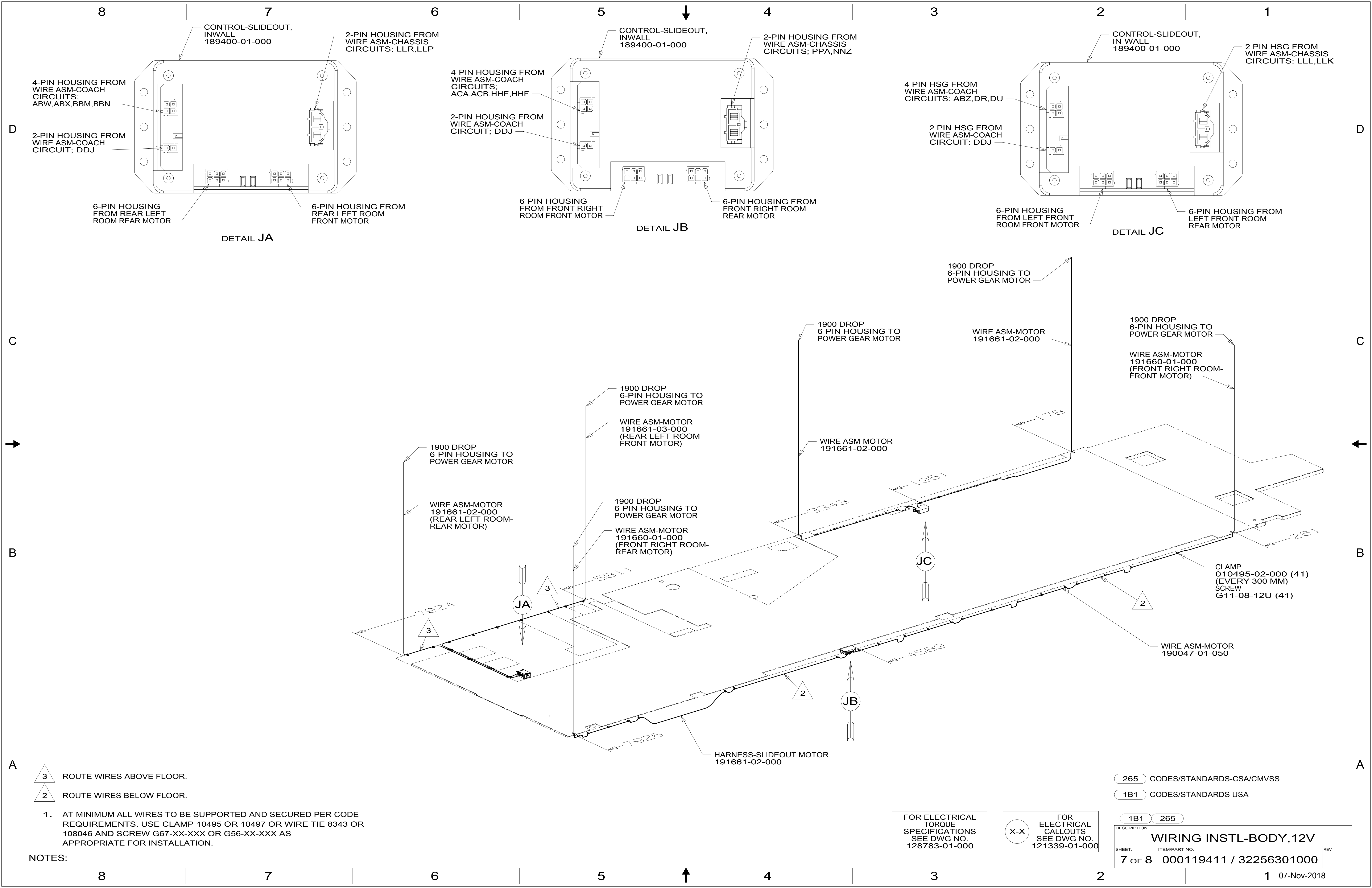

- 3 ROUTE WIRES ABOVE FLOOR.
- 2 ROUTE WIRES BELOW FLOOR.

1. AT MINIMUM ALL WIRES TO BE SUPPORTED AND SECURED PER CODE REQUIREMENTS. USE CLAMP 10495 OR 10497 OR WIRE TIE 8343 OR 108046 AND SCREW G67-XX-XXX OR G56-XX-XXX AS APPROPRIATE FOR INSTALLATION.

NOTES:

FOR ELECTRICAL TORQUE SPECIFICATIONS SEE DWG NO. 128783-01-000

FOR ELECTRICAL CALLOUTS SEE DWG NO. 121339-01-000

- 265 CODES/STANDARDS-CSA/CMVSS
- 1B1 CODES/STANDARDS USA

DESCRIPTION:		1B1 265	
WIRING INSTL-BODY, 12V			
SHEET:	ITEM/PART NO.:	REV:	
7 OF 8	000119411 / 32256301000		

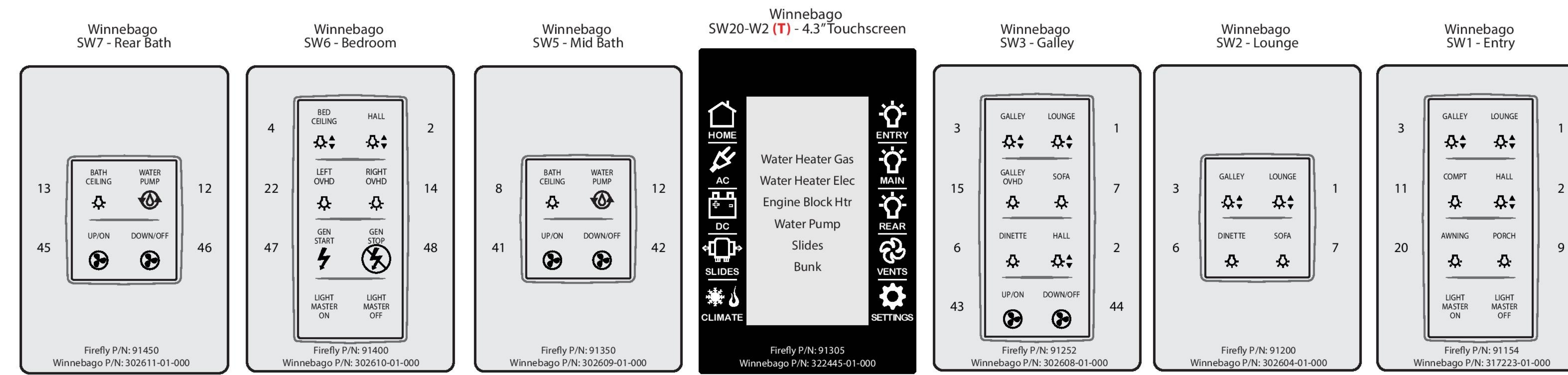
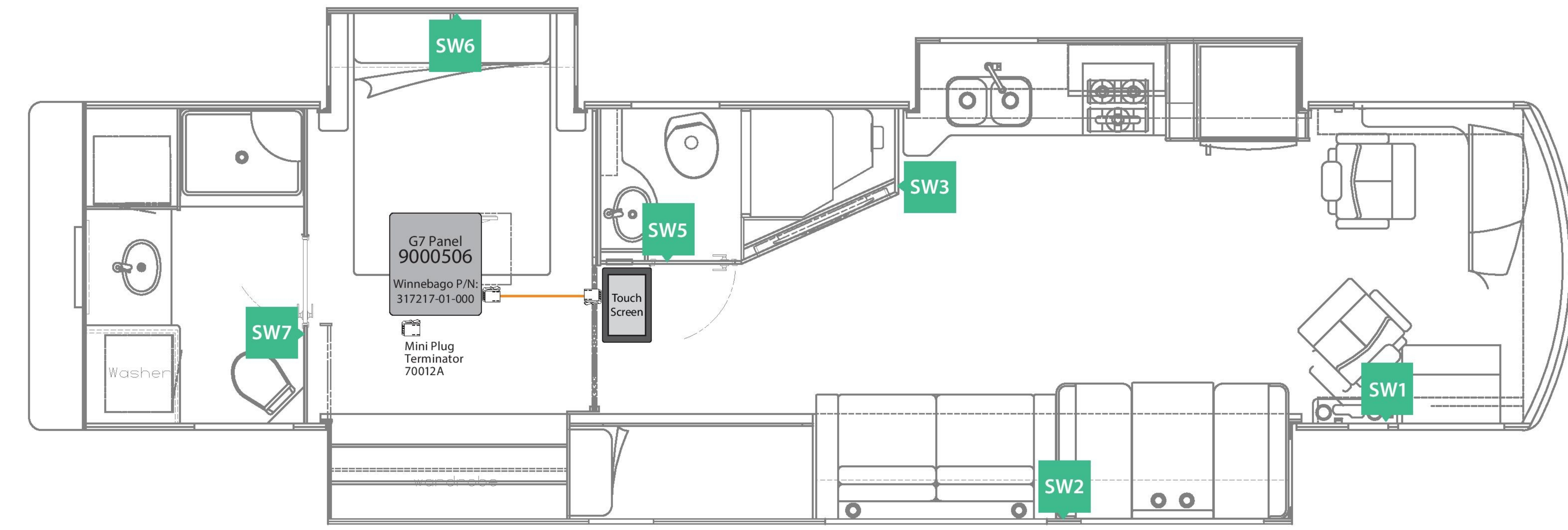

KIT*: Firefly P/N: 90852AC
 Winnebago P/N: 322449-01-000
 * Kits may not include all components shown on print.

WINNEBAGO - L38W - V3			DI: AD/MD	Network Legend	
Network Wiring Diagram and Switch Panel Layout			PI: AD/AA		
SSP-17 & 4.3" Screen (6v8)	Rev. 0v1	05/10/17		Trunk Cable	
				Drop Cable	
				Switch Position	

NOTES:
 1. ALL SWITCH PANELS ARE PART OF KIT # 000118591 / 322449-01-000.

FOR ELECTRICAL TORQUE SPECIFICATIONS SEE DWG NO. 128783-01-000

FOR ELECTRICAL CALLOUTS SEE DWG NO. 121339-01-000

265	CODES/STANDARDS-CSA/CMVSS
1B1	CODES/STANDARDS USA
1B1	265
DESCRIPTION: WIRING INSTL-BODY, 12V	
SHEET: 8 OF 8	ITEM/PART NO: 000119411 / 32256301000
REV 1 07-Nov-2018	