

8 7 6 5 4 3 2 1

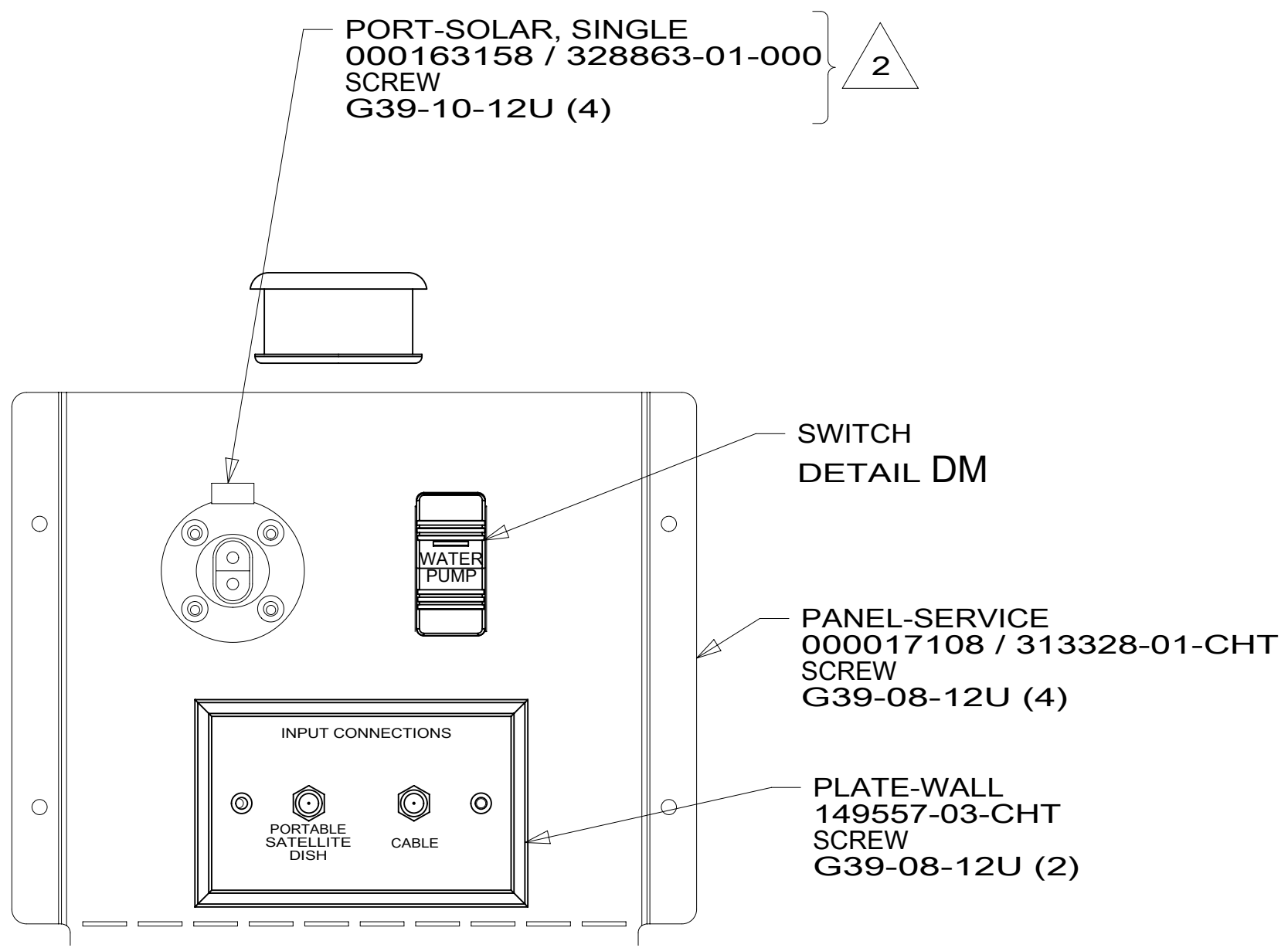

VIEW AA

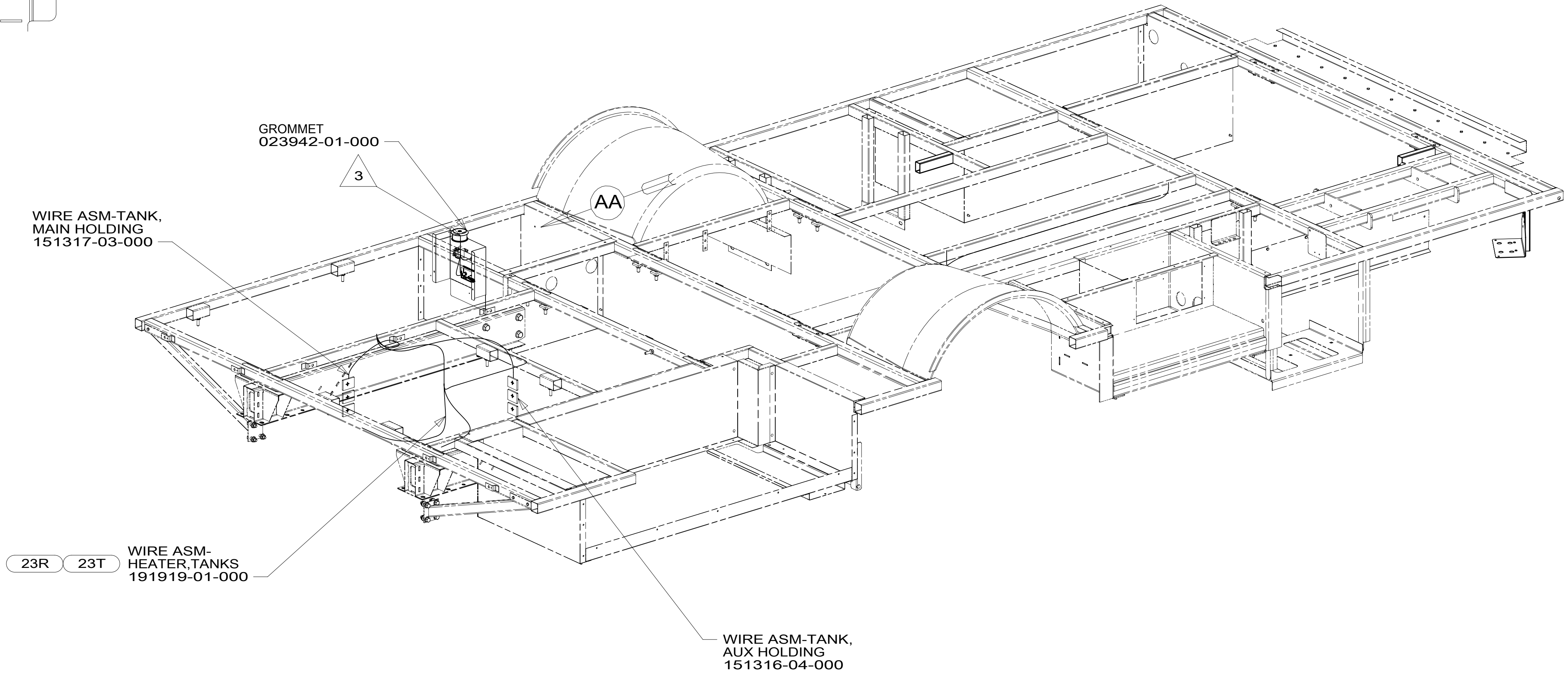

- 23T DRAINAGE SYSTEM-HEATED
- 23R DRAINAGE SYSTEM/HEAT-PREWIRE
- 265 CODES/STANDARDS-CSA/CMVSS
- 1B1 CODES/STANDARDS USA



DSNR:	ALL DIMENSIONS ARE IN MILLIMETERS
DIFFR:	
UNSPECIFIED TOLERANCES:	MATERIAL:
WHOLE DIM (X) : 3	
ONE-PLACE (X.X) : 1.5	
TWO-PLACE (X.XX) : 0.50	
ANGLE : 1°	
REFER TO ES0018 FOR FASTENER TIGHTENING GUIDELINES	WEIGHT: (LBS) FIRST USED: 18 423T

- 3 WIRE PASSES THROUGH FLOOR IN THIS AREA.
- 2 SPLICE YELLOW TO RED AND WHITE TO BLACK.

1. AT MINIMUM ALL WIRES TO BE SUPPORTED AND SECURED PER CODE REQUIREMENTS. USE CLAMP 10495 OR 10497 OR WIRE TIE 8343 OR 108046 AND SCREW G67-XX-XXX OR G56-XX-XXX AS APPROPRIATE FOR INSTALLATION.

FOR ELECTRICAL TORQUE SPECIFICATIONS SEE DWG NO. 128783-01-000

FOR ELECTRICAL CALLOUTS SEE DWG NO. 121339-01-000

DESCRIPTION:
WIRING INSTL-BODY, 12V

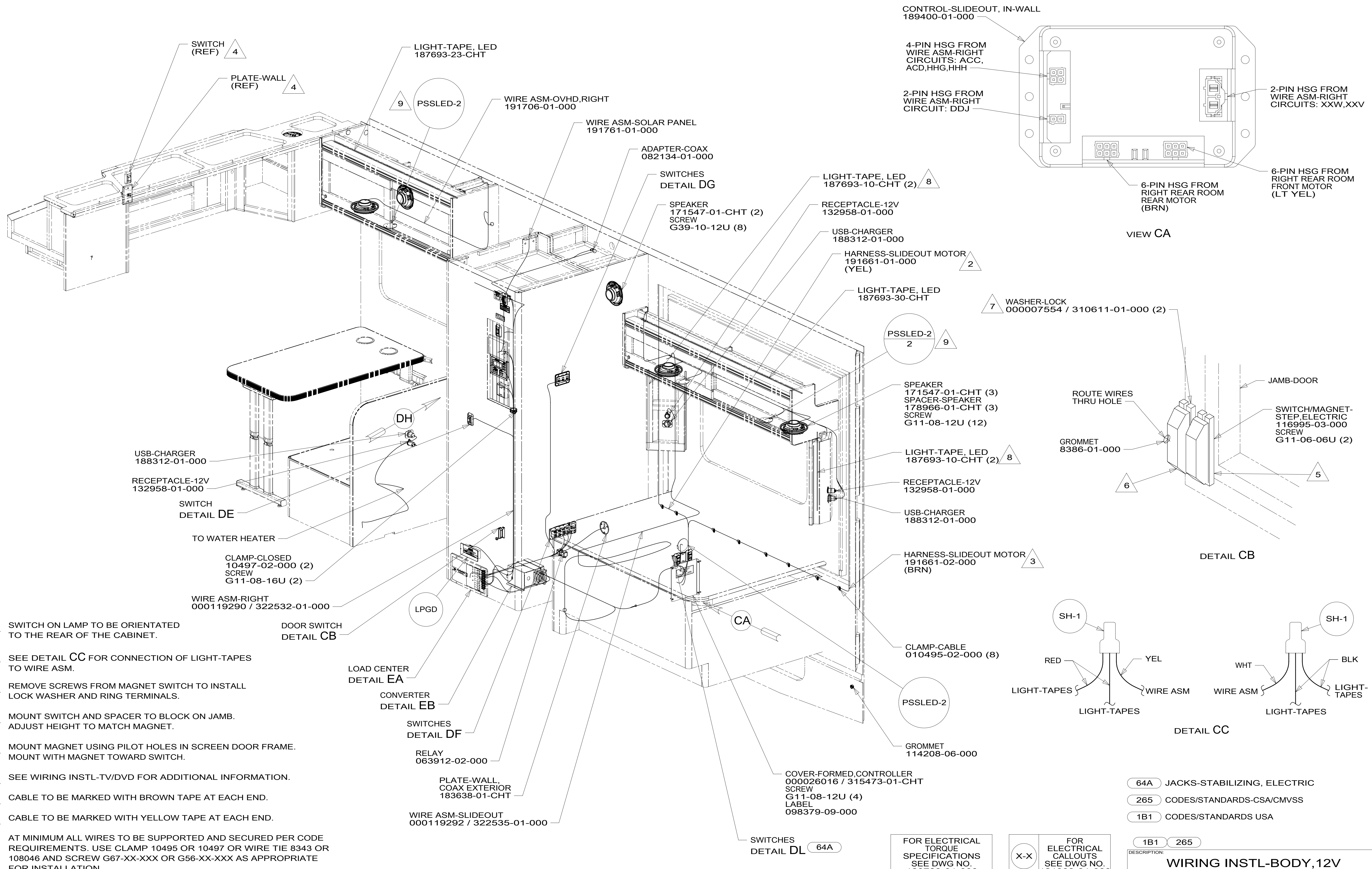

NOTES:

FOR ELECTRICAL TORQUE SPECIFICATIONS SEE DWG NO. 128783-01-000

FOR ELECTRICAL CALLOUTS SEE DWG NO. 121339-01-000

- 64A JACKS-STABILIZING, ELECTRIC
- 265 CODES/STANDARDS-CSA/CMVSS
- 1B1 CODES/STANDARDS USA

DESCRIPTION: WIRING INSTL-BODY, 12V		
SHEET: 3 OF 6	ITEM/PART NO.: 000118447 / 32242501000	REV
07-May-2018		

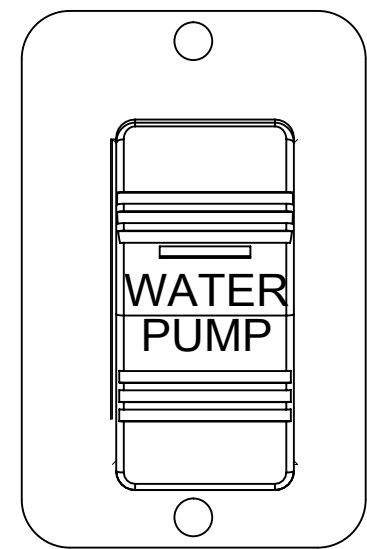

SWITCH-ROCKER
108357-21-000
ACTUATOR-SWITCH
108356-23-CHT
PLATE-SWITCH
144363-02-CHT
SCREW
G11-06-10U (2)

DETAIL DA

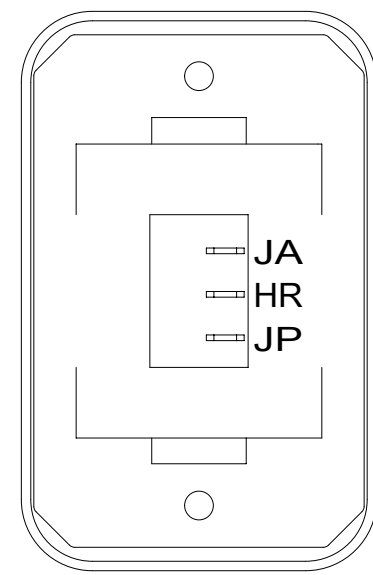

SWITCH-ROCKER
135740-06-CHT
SWITCH-BASE
135741-01-CHT
SWITCH-BEZEL
135742-01-CHT
SCREW
G11-08-08U (2)

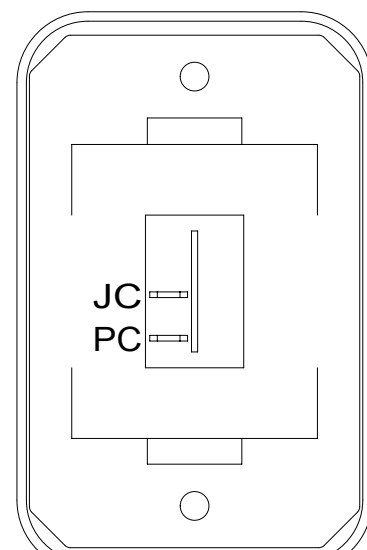

SWITCH-ROCKER
135740-01-CHT
SWITCH-BASE
135741-01-CHT
SWITCH-BEZEL
135742-01-CHT
SCREW
G11-08-08U (2)

DETAIL DB

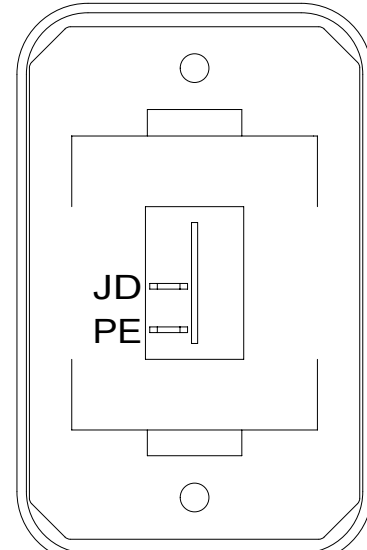

SWITCH-ROCKER
135740-01-CHT
SWITCH-BASE
135741-01-CHT
SWITCH-BEZEL
135742-01-CHT
SCREW
G11-08-08U (2)

DETAIL DC

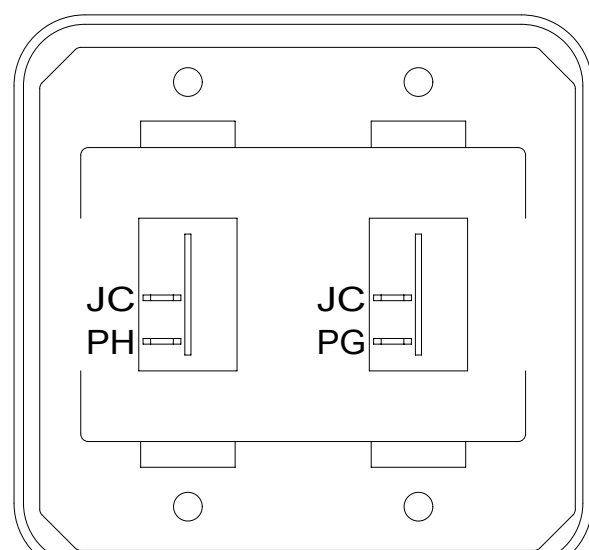

SWITCH-ROCKER
135740-01-CHT (2)
SWITCH-BASE
135741-02-CHT
SWITCH-BEZEL
135742-02-CHT
SCREW
G11-08-08U (4)

DETAIL DD

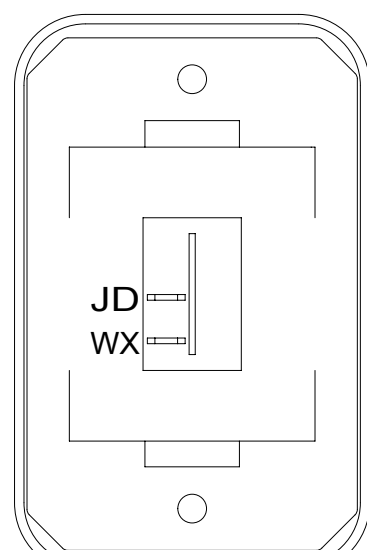

SWITCH-ROCKER
135740-01-CHT
SWITCH-BASE
135741-01-CHT
SWITCH-BEZEL
135742-01-CHT
SCREW
G11-08-08U (2)

DETAIL DE

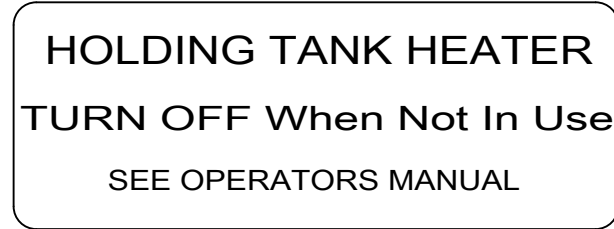

LABEL-SWITCH,
HTR,HOLDING TK
134563-01-CHT

DETAIL DJ 23T 23R

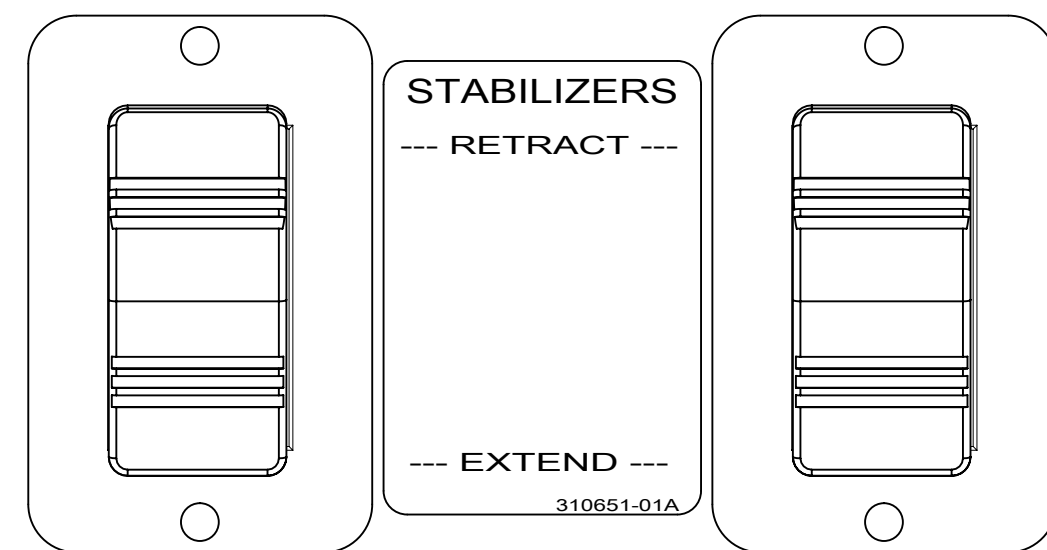

DETAIL DL 64A

SWITCH-ROCKER
108357-06-000 (2)
ACTUATOR
108356-01-000 (2)
LABEL
000007799 / 310651-01-CHT
SWITCH-BLANK
096241-03-000 (2)
PLATE-SWITCH
144363-02-CHT (2)
SCREW
G11-08-08U (4)

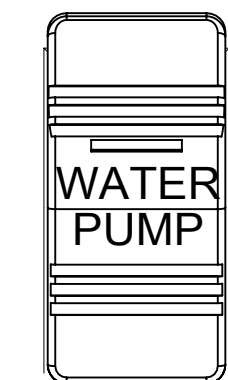

VIEW DM

SWITCH-ROCKER
108357-21-000
ACTUATOR-SWITCH
108356-23-CHT

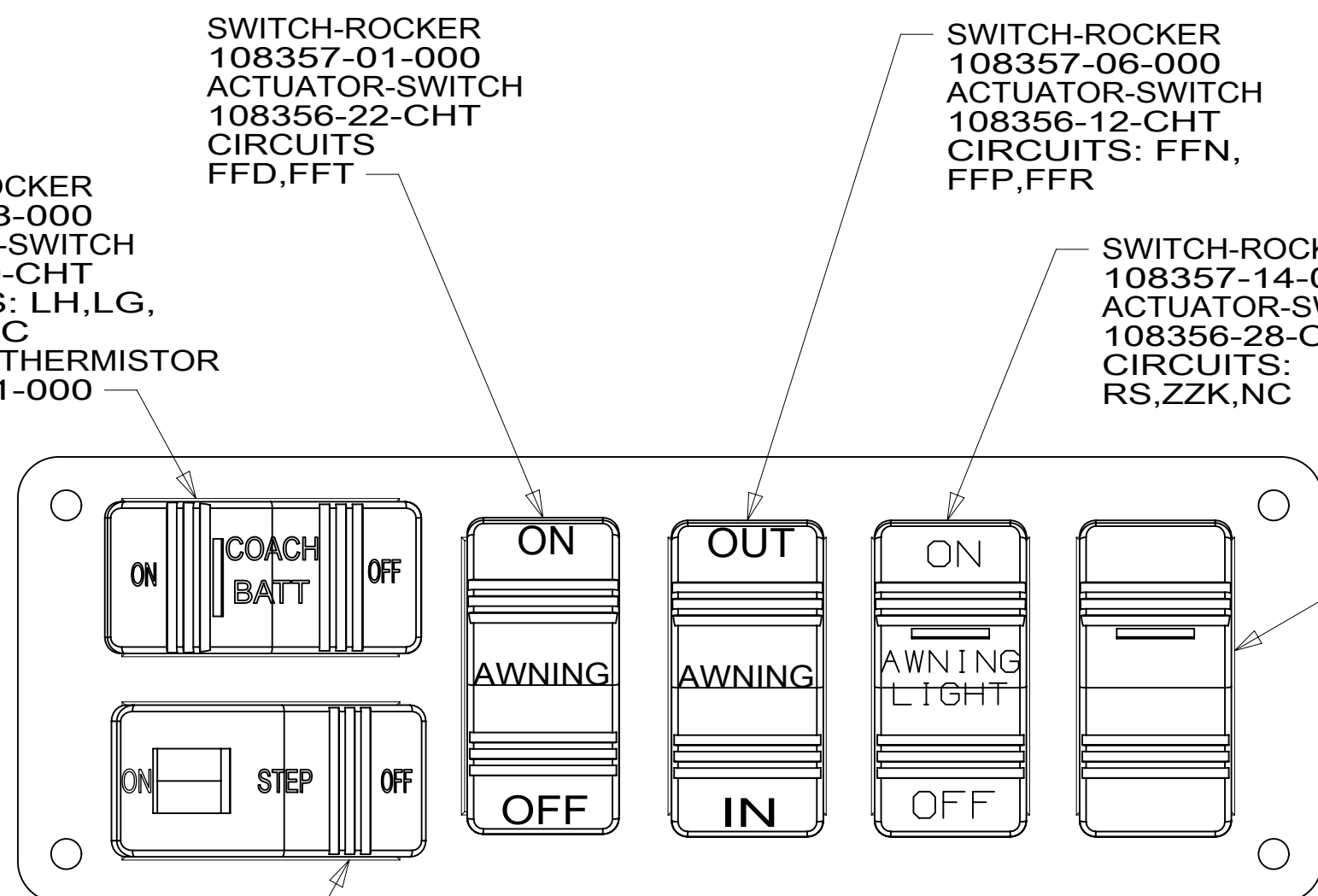

DETAIL DF

SWITCH-ROCKER
108357-01-000
ACTUATOR-SWITCH
108356-22-CHT
CIRCUITS: FFD,FFT

SWITCH-ROCKER
108357-06-000
ACTUATOR-SWITCH
108356-12-CHT
CIRCUITS: FFN,FFR

SWITCH-ROCKER
108357-14-000
ACTUATOR-SWITCH
108356-28-CHT
CIRCUITS:
RS,ZZK,NC

SWITCH-ROCKER
108357-14-000
ACTUATOR-SWITCH
108356-03-CHT
CIRCUITS:
AES,AET,NC

SWITCH-ROCKER
108357-19-000
CIRCUITS: ER,ES

PLATE-SWITCH
00022055 / 314395-01-CHT
SCREW
G11-06-10U (4)

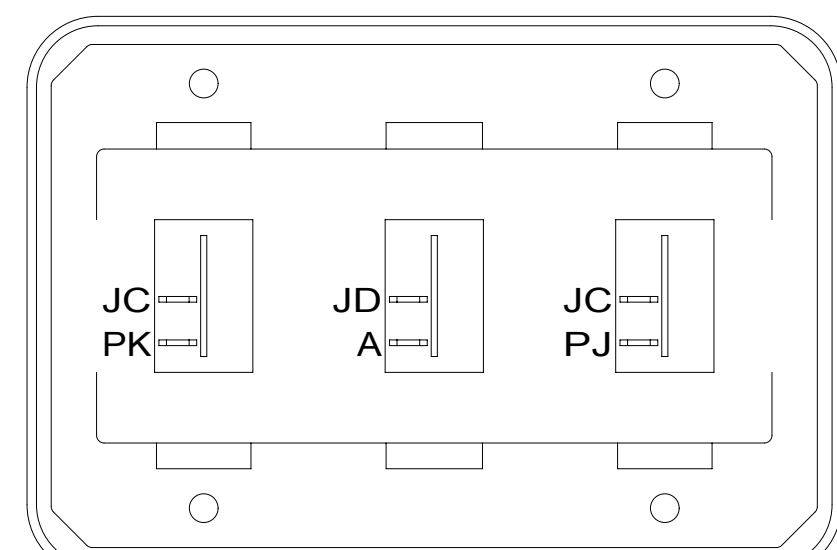

DETAIL DG

SWITCH-ROCKER
135740-01-CHT (3)
SWITCH-BASE
135741-03-CHT
SWITCH-BEZEL
135742-03-CHT
SCREW
G11-08-08U (4)

401 REMOTE PANEL-INVERTER
000037772 / 318694-01-CHT
SCREW
G11-06-08U (2)
40A CABLE-DATA
000038250 / 318769-01-000
SWITCH-BLANK
138253-01-CHT
SWITCH-BASE
135741-01-CHT
SWITCH-BEZEL
135742-01-CHT
SCREW
G11-08-08U

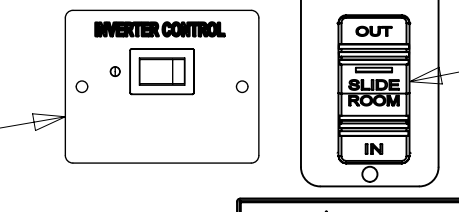

WARNING
CLIPPER HAZARD: Keep people and objects
clear of the trailer and outside of the vehicle
when operating. Failure to comply could
result in death or serious injury.

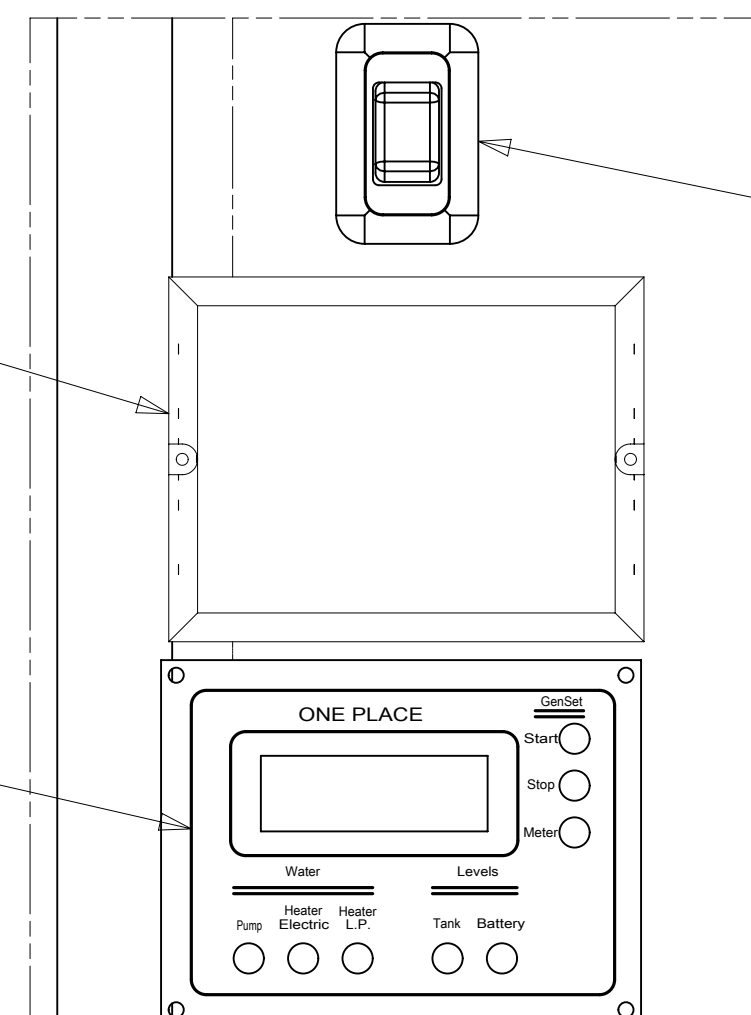
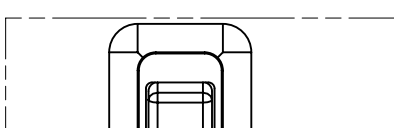

VIEW DH

CONTROL-CHARGE,
SOLAR 30 AMP
191278-01-000
SCREW
G11-08-08U (2)
DETAIL DK

PANEL-MONITOR,LCD
175724-01-000
SCREW
G11-08-08U (4)

DETAIL DK

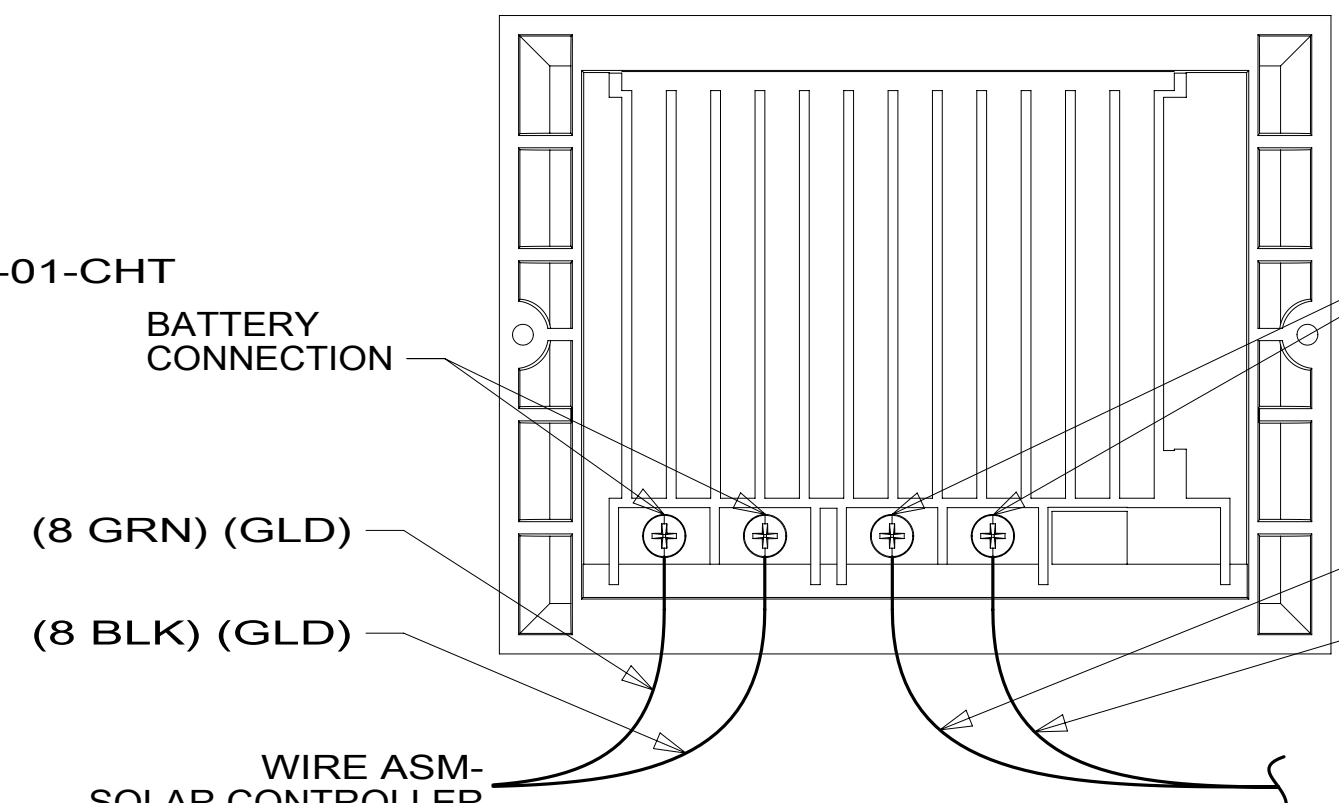

(8 GRN) (GLD)
(8 BLK) (GLD)

SOLAR PANEL
CONNECTION

(8 GRN) (YEL)
(8 BLK) (YEL)

WIRE ASM-
SOLAR PANEL

FOR ELECTRICAL
TORQUE
SPECIFICATIONS
SEE DWG NO.
128783-01-000

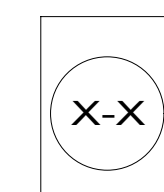

FOR ELECTRICAL
CALLOUTS
SEE DWG NO.
121339-01-000

- 60T JACKS-STABILIZING,ELECT W/O
- 401 INVERTER-DC/AC, 1000 WATT
- 40A INVERTER-DC/AC WITHOUT
- 64A JACKS-STABILIZING, ELECTRIC
- 23R DRAINAGE SYSTEM/HEAT-PREWIRE
- 23T DRAINAGE SYSTEM-HEATED
- 265 CODES/STANDARDS-CSA/CMVSS
- 1B1 CODES/STANDARDS USA

DESCRIPTION: WIRING INSTL-BODY, 12V	
SHEET: 4 OF 6	ITEM/PART NO: 000118447 / 32242501000
REV 07-May-2018	

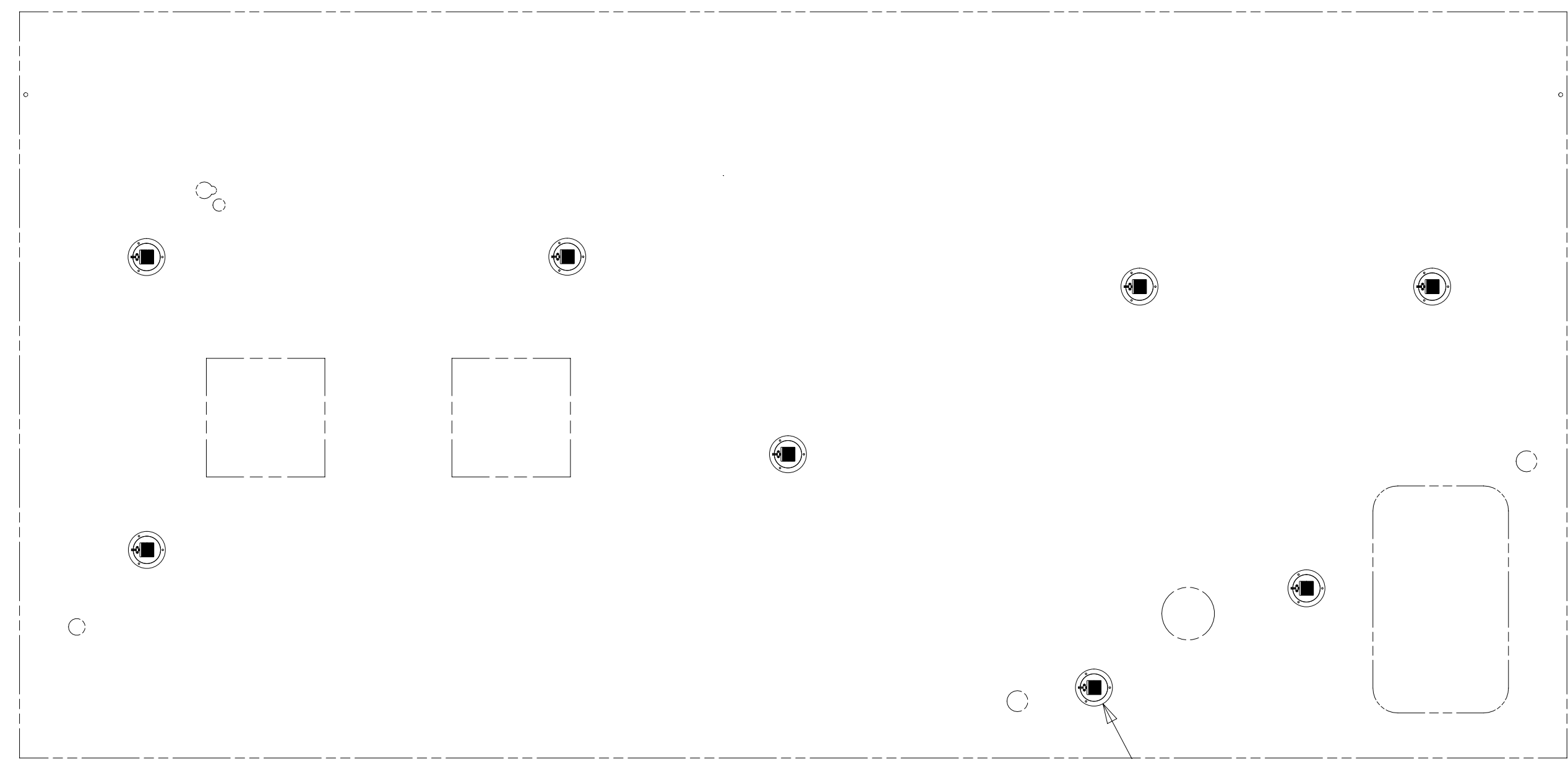

PRLED-4
8

PANEL-SOLAR 100 WATT, FLEXIBLE
000131101 / 325665-01-000 (2)
WASHER
077071-01-000 (12)
SCREW
000G39-10-16U (12)

DETAIL FB

PORT-SOLAR,
3 POSITION
191277-01-CHT
DETAIL FC

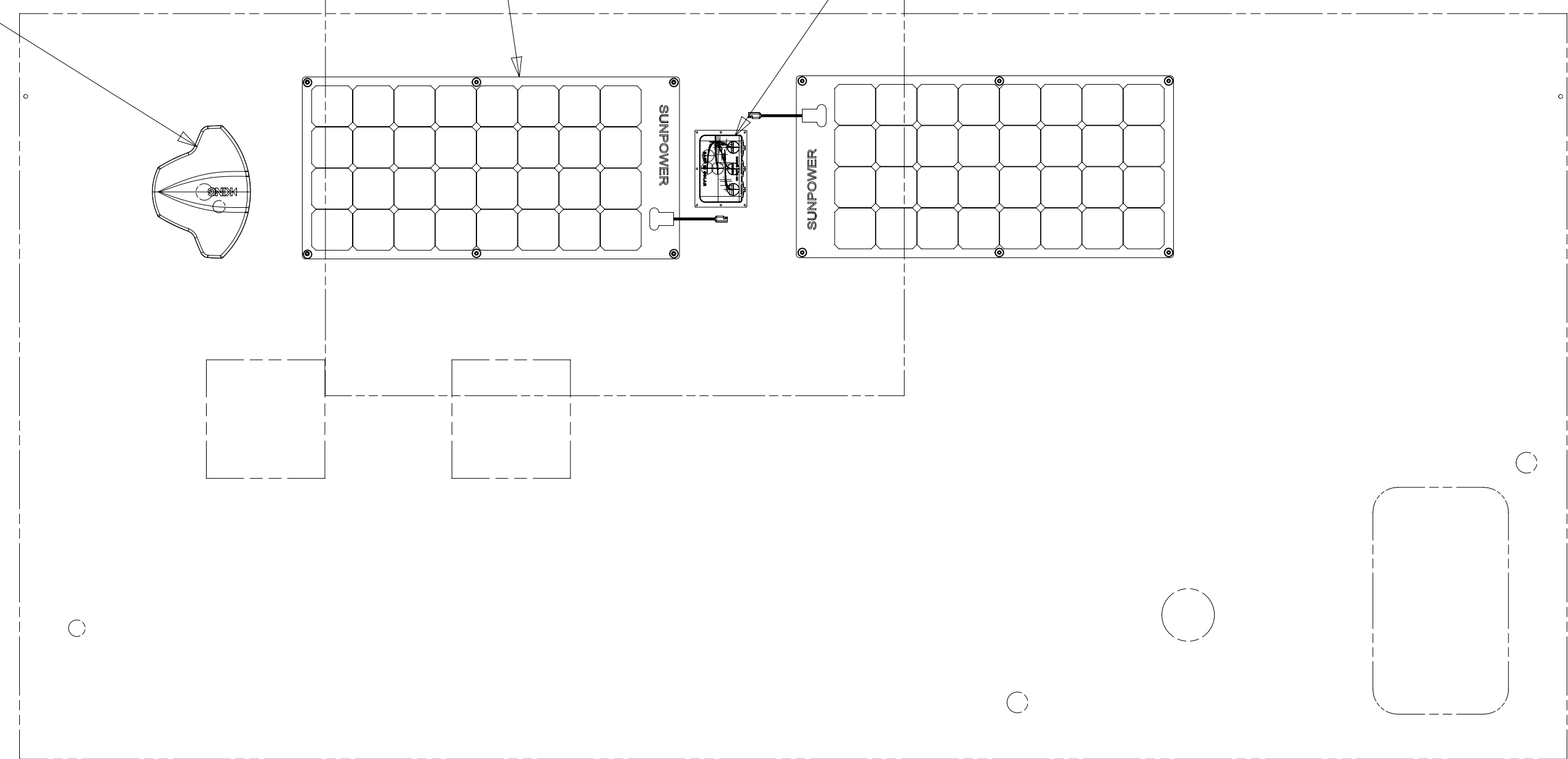

1 ANTENNA-TV ROOF
000039180 / 318992-01-CHT
SCREW
G67-10-12U (6)

ANTENNA-RADIO, 16 RUBBER
090944-01-000
BRACKET-ANTENNA GROUND
147741-01-CHT
VIEW FA

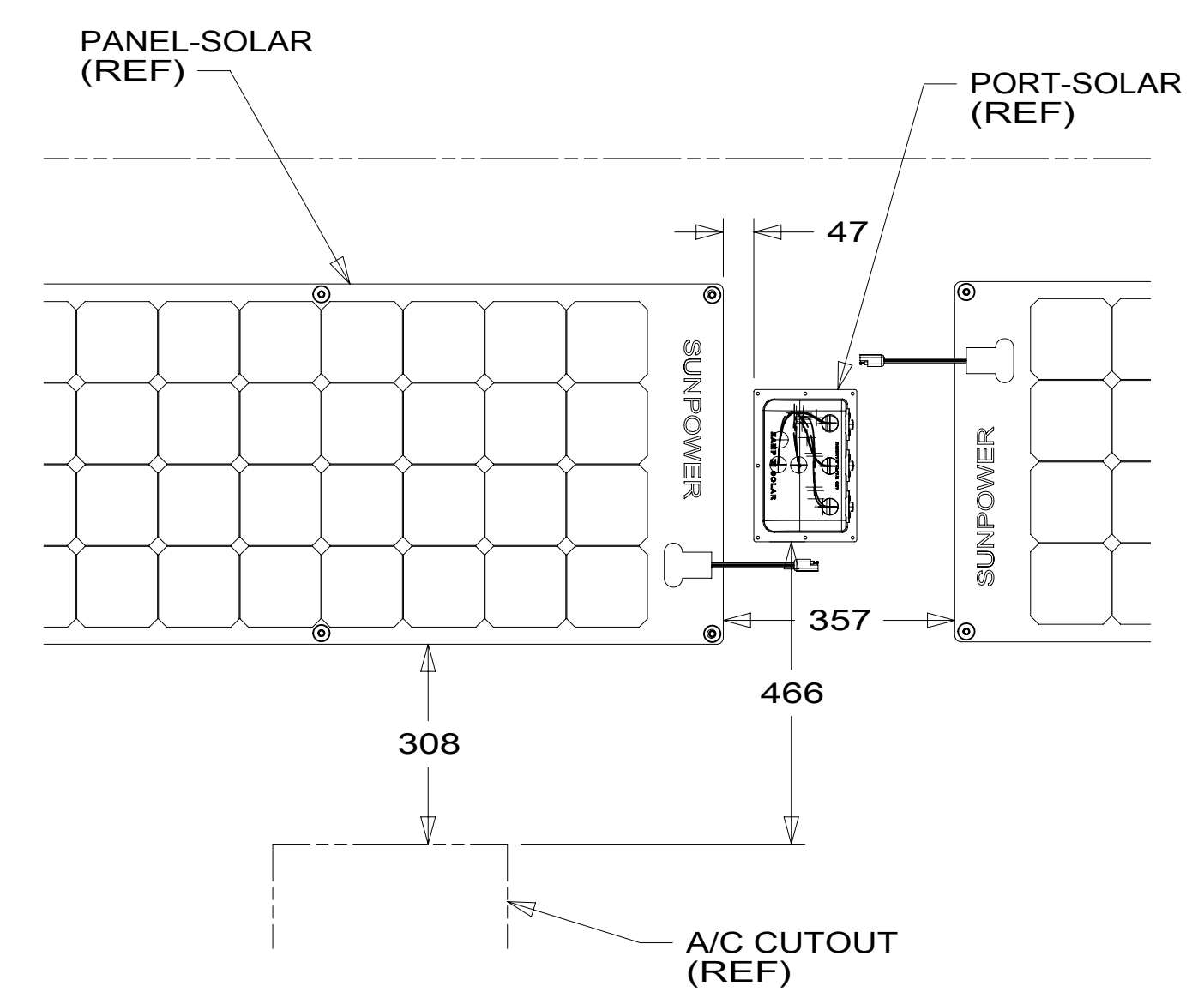

DETAIL FB

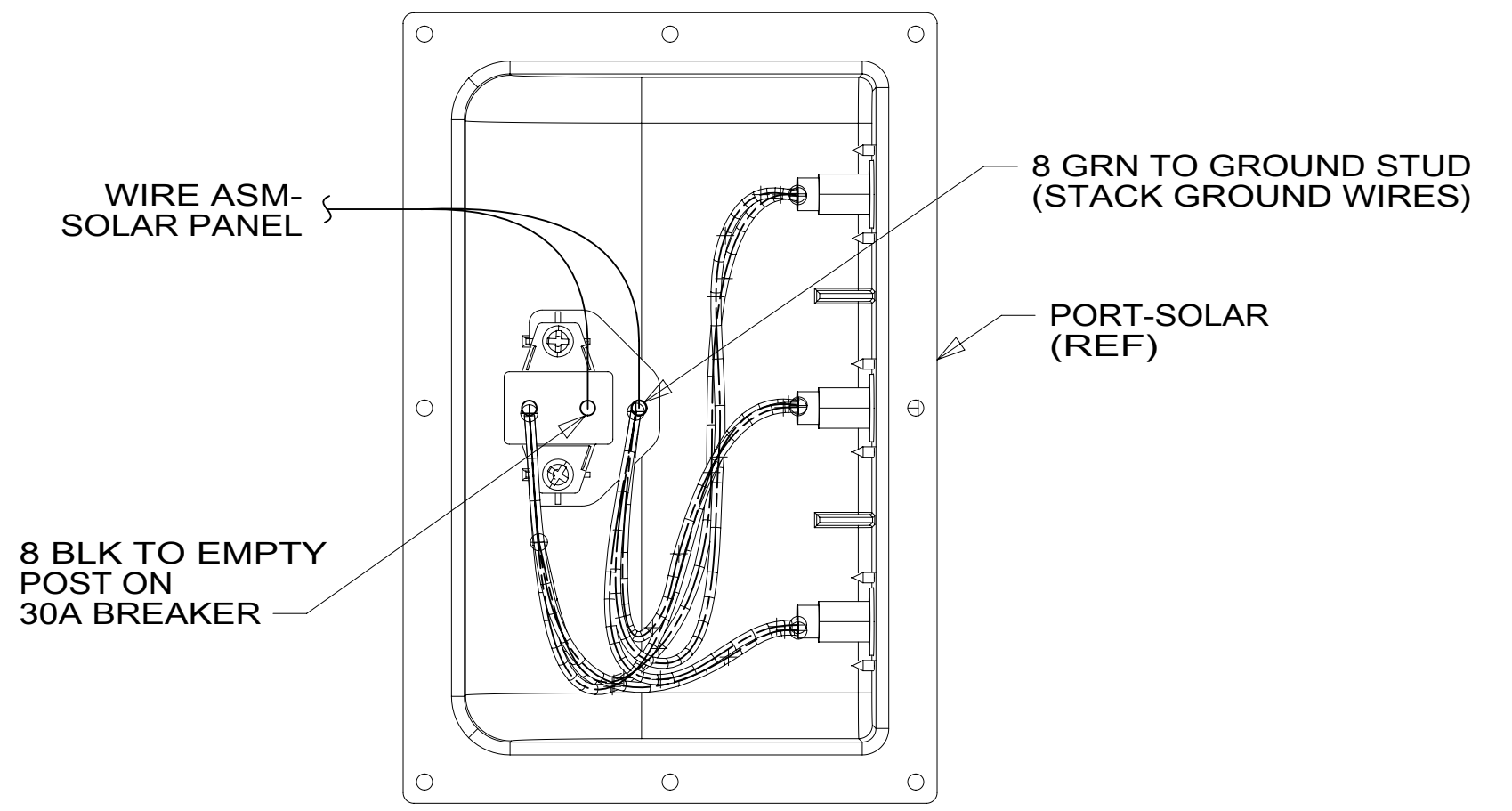

DETAIL FC

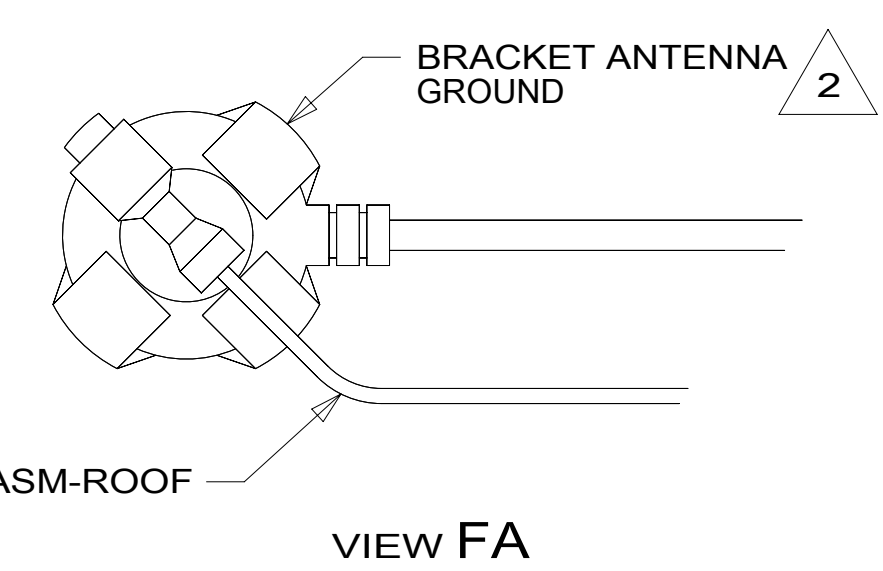

VIEW FA

2 WRAP BRACKET LEGS AROUND ANTENNA BASE.
1 SEE ANTENNA INSTALLATION MANUAL FOR
CORRECT INSTALLATION PROCEDURE.

NOTES:

FOR ELECTRICAL
TORQUE
SPECIFICATIONS
SEE DWG NO.
128783-01-000

FOR
ELECTRICAL
CALLOUTS
SEE DWG NO.
121339-01-000

265 CODES/STANDARDS-CSA/CMVSS
1B1 CODES/STANDARDS USA

DESCRIPTION:	
1B1 265	
WIRING INSTL-BODY, 12V	
SHEET:	ITEM/PART NO:
6 OF 6	000118447 / 32242501000
REV	