

- 10. LAVATORY FAUCET SPOUT TO BE TURNED 180 DEGREES SO THE ON/OFF HANDLE IS FACING TOWARD THE CENTER OF THE COACH.
- 9. INSTALL BYPASS PLUG FOR SYSTEM TESTING AND SHIPPING.
- 8. ALL CRIMP FITTINGS TO 1/2" PEX TUBING REQUIRE 1/2" CLAMP 000156249 / 326670-01-000.
- 7. ALL CRIMP FITTINGS TO 5/8" PEX TUBING REQUIRE 5/8" CLAMP 000156248 / 326669-01-000.
- 6. LABEL HOT AND COLD SUPPLY TUBES AND TAPE FITTING TO TUBE BEFORE CABINET SET TO PREVENT MOVEMENT.
- 5. ADD PIPE WRAP (LADDER SCRAP 110157-02-000) INSULATION.
- 4. ADD TEFLON TAPE 010405-02-000.
- 3. ALL TUBING TO BE SECURED AT 1200 INTERVALS MAXIMUM WITH CLAMP 010495-01-000 AND SCREW 000G67-10-12U OR EQUIVALENT.
- 2. TUBING TO BE INSTALLED WITH SUFFICIENT SLOPE TO PROVIDE DRAINAGE TO NEAREST VALVE.
- 1. PLASTIC FITTINGS TO BE SEALED WITH SEALANT 084456-01-000.

NOTES:

1BU WTR HTR TKLS W/RECIRCUL PUMP



DSNR:		ALL DIMENSIONS ARE IN MILLIMETERS	
DIFTR:		MATERIAL:	
UNSPECIFIED TOLERANCES:			
WHOLE DIM (X)	± 3		
ONE-PLACE (X.X)	± 1.5		
TWO-PLACE (X.XX)	± 0.50		
ANGLE	± 1°		
REFER TO ES0018 FOR FASTENER TIGHTENING GUIDELINES		WEIGHT: (LBS)	FIRST USED: (REF)
			18 524J
DESCRIPTION: WATER SYSTEM INSTL			
SHEET: 1 OF 4	ITEM/PART NO: 000114732 / 32217501000	REV:	

X-X
FOR WATER CALLOUTS SEE DWG NO. 000209446 / 303369-01-000

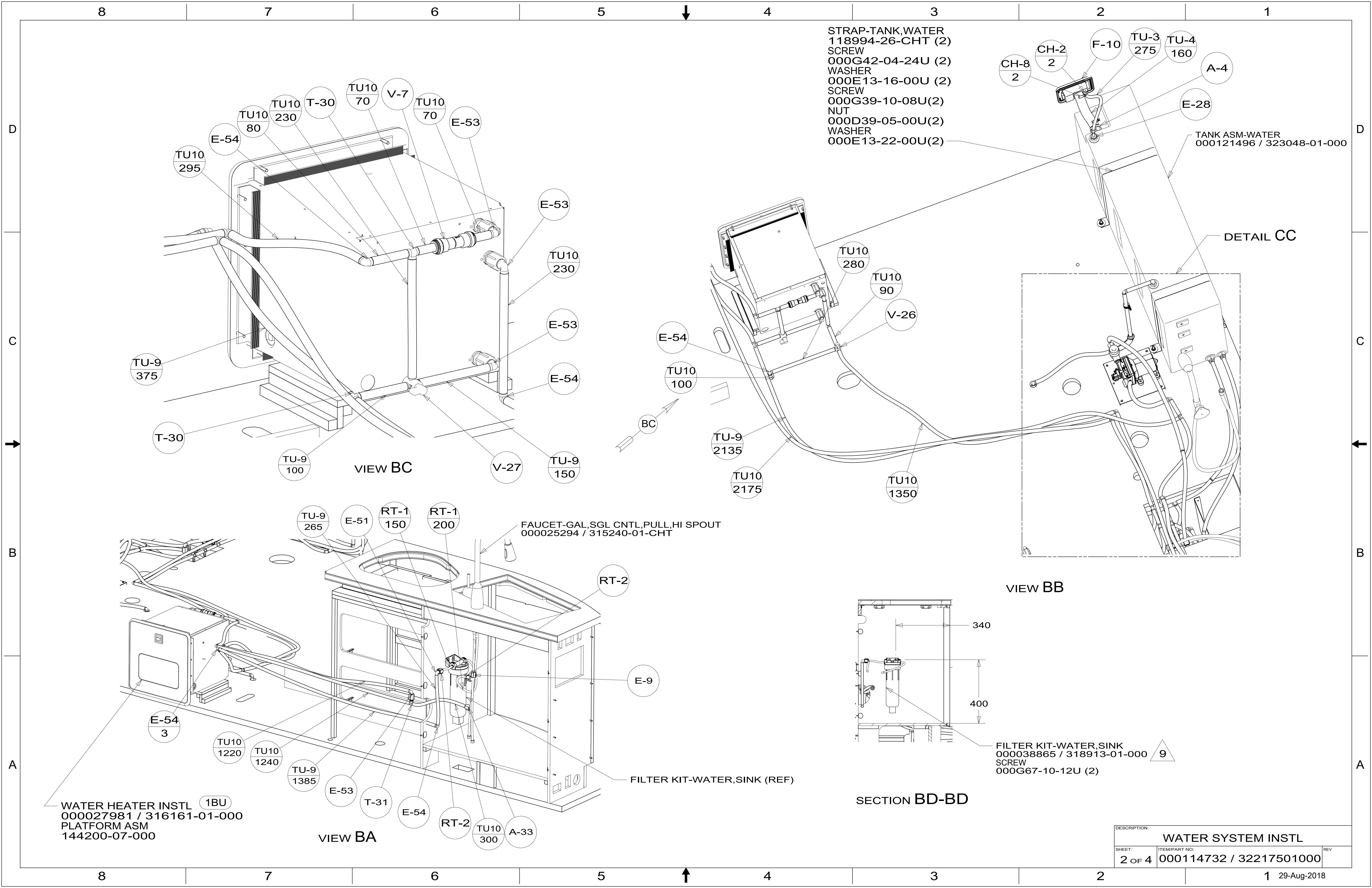

BREAKER-VACUUM,FLUSHING SYS
000030488 / 316731-01-000

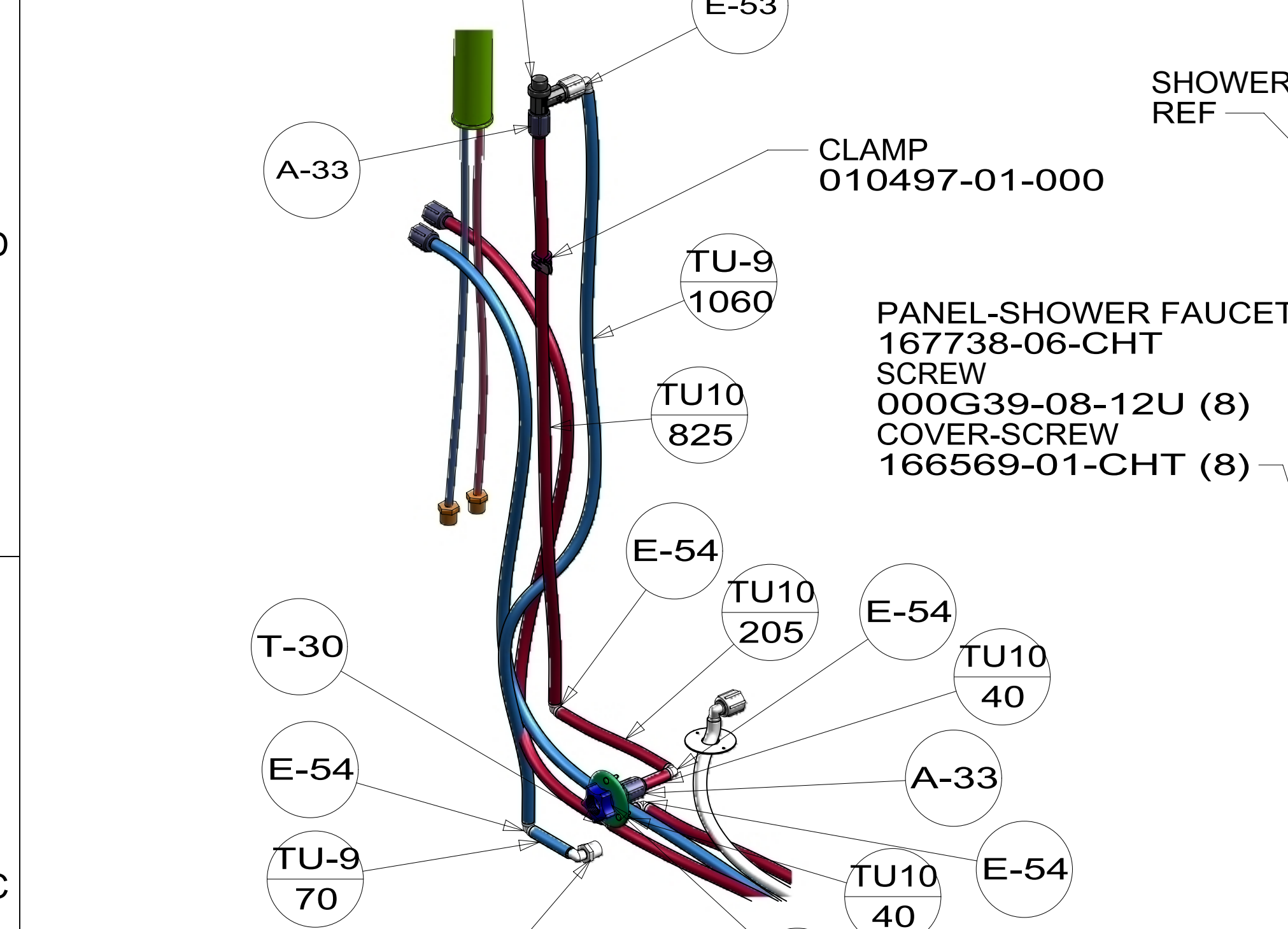

TANK FITTING (REF) DETAIL CE

DETAIL CE

FAUCET-LAV, SGL CTRL, NO WASTE
000034499 / 317788-01-CHT

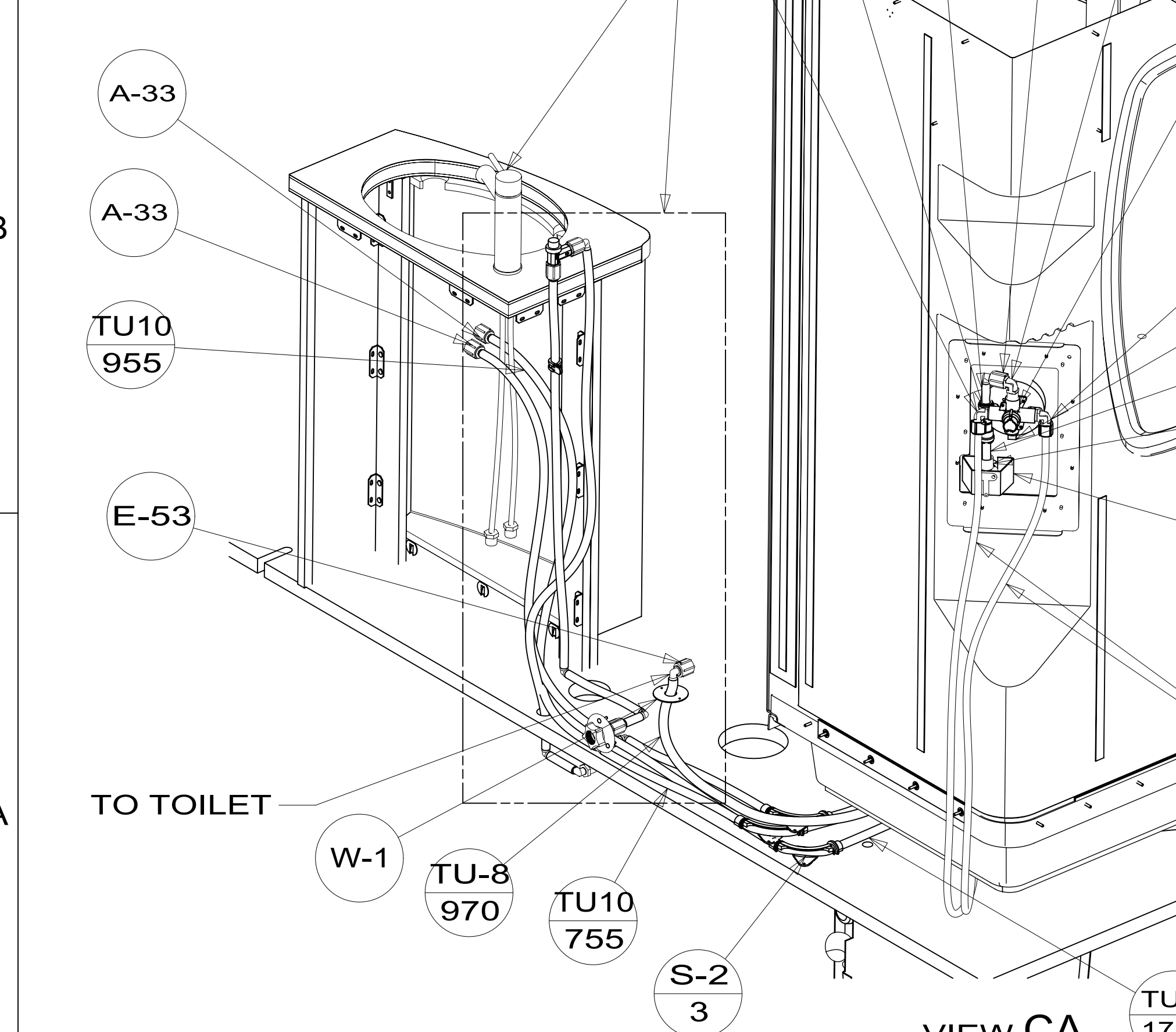

VIEW CA

SECTION CB-CB

SHOWER HEAD-W/HOSE & BRKT
000162058 / 328585-01-CHT

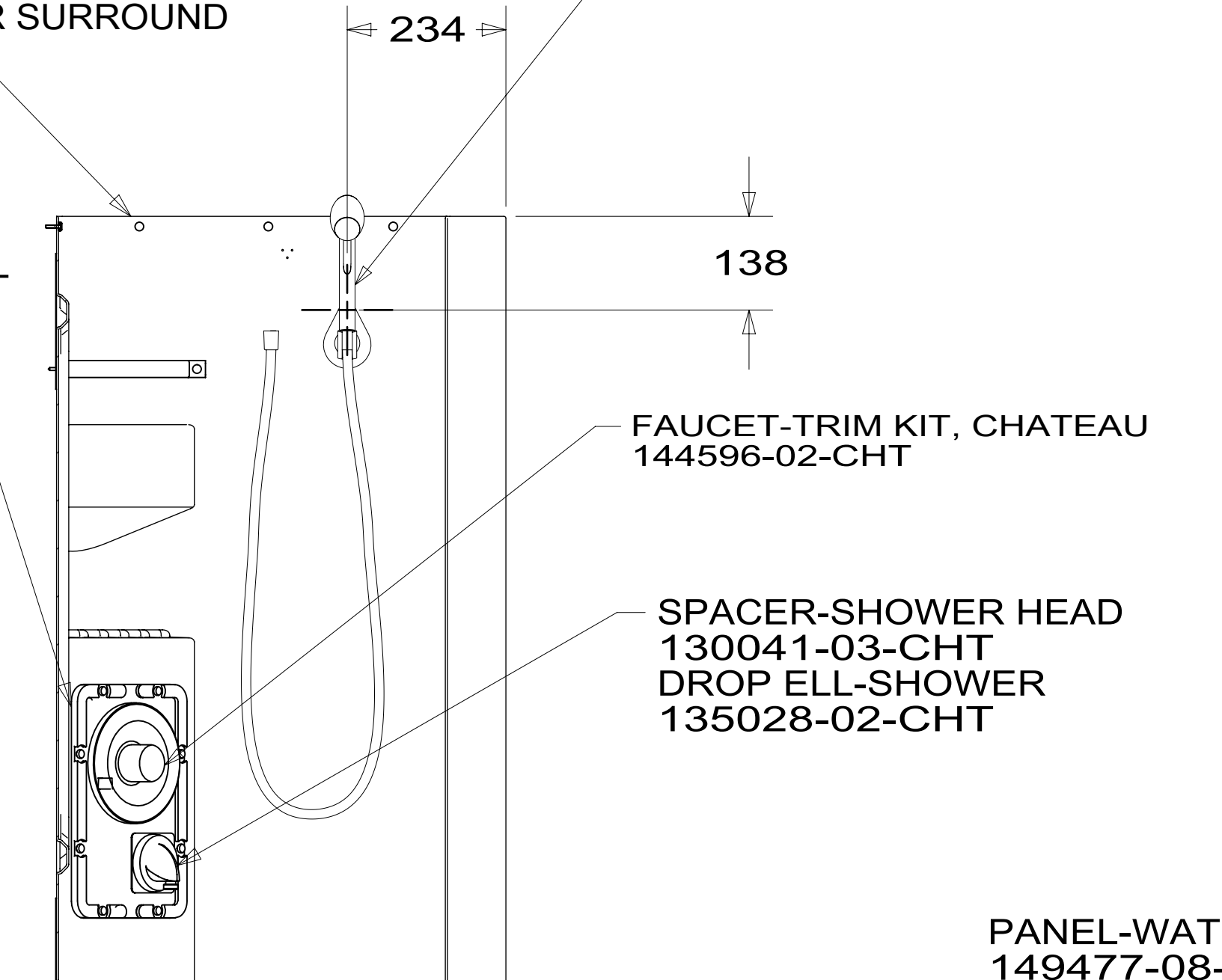

PANEL-WATER PUMP
149477-08-CHT
FOAM 140364-01-CHT
SCREW 000G39-08-16U (4)

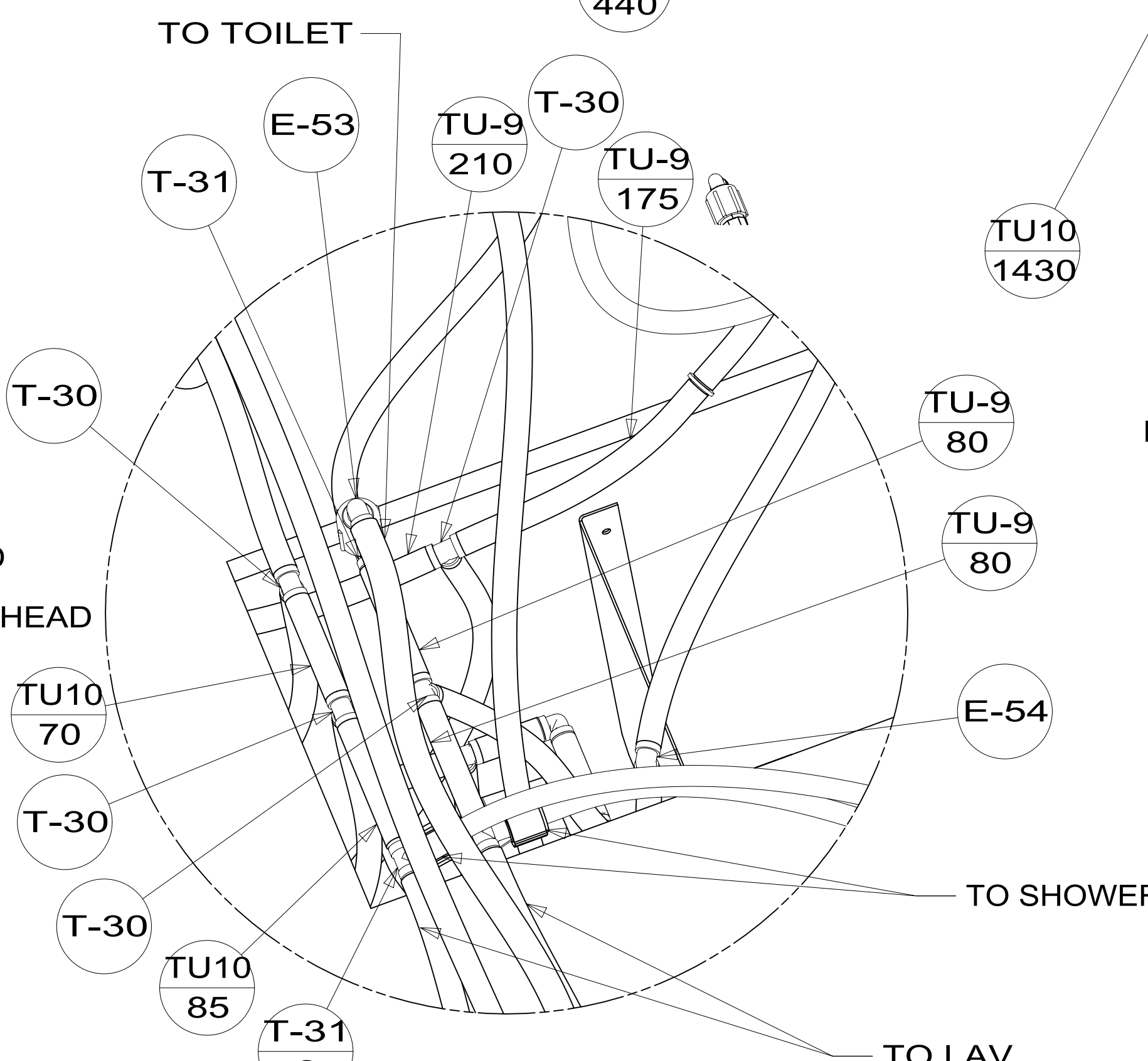

DETAIL CD

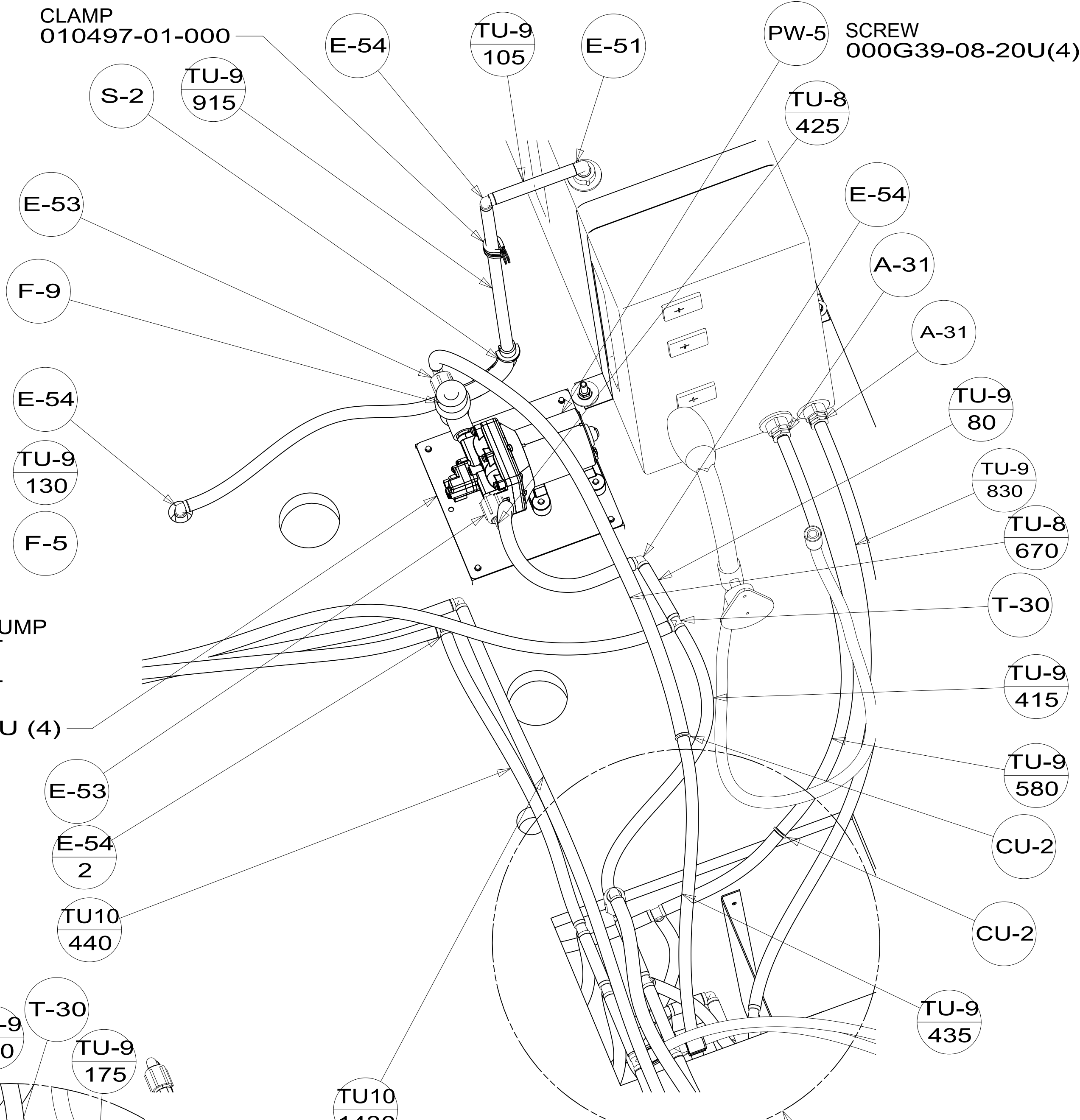

DETAIL CC

DETAIL CD

DESCRIPTION:		
WATER SYSTEM INSTL		
SHEET:	ITEM/PART NO:	REV
3 OF 4	000114732 / 32217501000	

