

NUT-PAL,WASHER TYPE
112722-01-CHT (2)

PANEL-WIRE COVER
188268-02-CHT

RIVET
000H15-04-02R (2)

SEAL-TRIM
113452-01-000
(70 MM)

PANEL-WIRE COVER
188268-01-CHT

EXTENDER-SHAFT,ANTENNA
109889-02-000
NUT
OMD54U-06-000 (2)

SEAL-TRIM
113452-01-000
(270 MM)

MOBILEYE
36C

WJ,AFM TO STABILIZERS
DOWN INDICATOR LIGHT
AND ALARM

LJ,LR,KE TO BATTERY
BOOST SWITCH

STARTER CABLE
TO CHASSIS BATTERY
DETAIL AA

TO PSM
(AEU,AEW,AEX,AEZ,
AEY,AF,AFB,AFD)
DETAIL GE

MOBILEYE 630-SPRINTER, PSM
000121825 / 323133-01-000

TO REAR
VIEW MONITOR
(RADIO)

SEAL-TRIM
113452-01-000
(190 MM)

AC

AC

VIEW AB

DROP TO SPRINTER
CHASSIS WIRING
UNDER DRIVERS SEAT

WIRING TO AMP
WIRING TO SUB

TO SLIDEOUT CONTROL

TO SLIDEOUT

TO LP SHUTOFF SWITCH
DETAIL BB

TO LP TANK

TO STEP
DOOR SWITCH

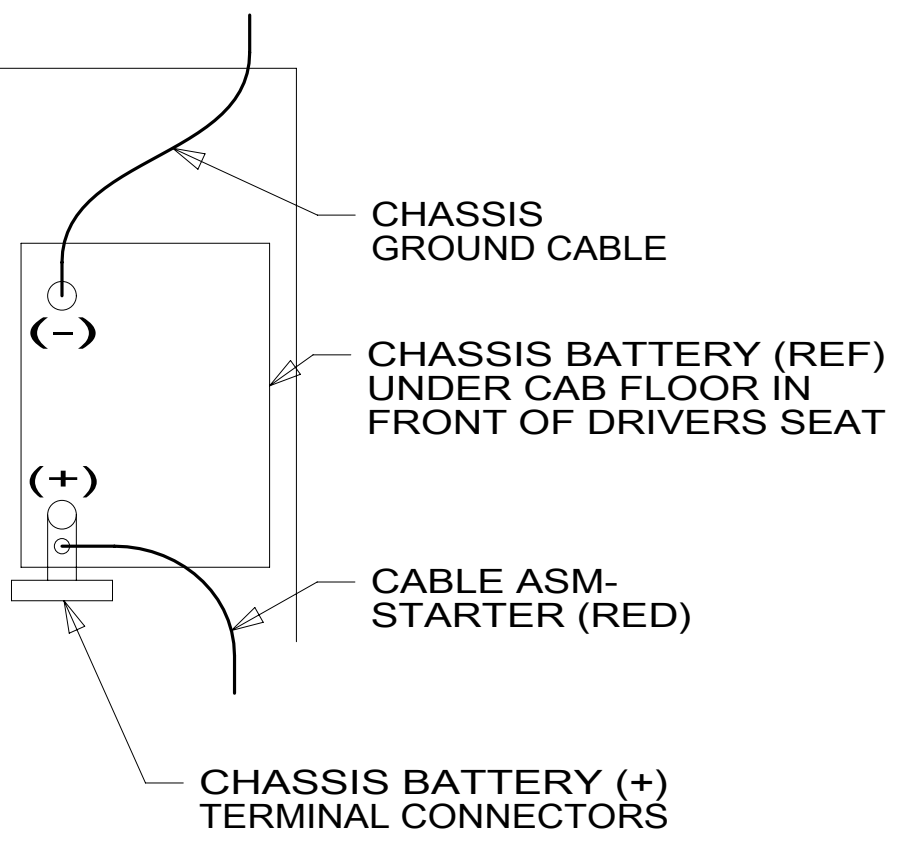

DETAIL AA

TO STABILIZER
SWITCHES

HSGS TO
STABILIZERS

WIRE ASM-CHASSIS
00011201 / 32156001000

TO WIRE
ASM-COACH

GENERATOR CONTROL CABLE

GENERATOR CONTROL CABLE
TO GENERATOR

TO GENERATOR

TO WIRE ASM-
TAILLAMPS

- 9 REMOVE PLASTIC TRAY AND DISCARD.
- 8 10-PIN HOUSING CONNECTS TO GENERATOR.
- 7 INSTALL NUT SO THAT IT IS FLUSH WITH TOP OF EXTENDER-SHAFT.
- 6 ROUTE GENERATOR CONTROL CABEL ALONG WIRE ASM-CHASSIS THROUGH FLOOR IN THIS AREA.
- 5 WITH FEATURE 33F CABLE SUPPLIED WITH DIESEL GENERATOR.
- 4 COIL AND SECURE WIRES TO BEHIND DASH PANEL WITH 60T
- 3 CUT WIRE TIE AROUND SPRINTER SEAL, ROUTE THE CHASSIS WIRING THROUGH HOLE AND WIRE TIE SEAL WITH WIRE TIE 8343-04-000.
- 2 12-PIN HOUSING TO BE ROUTED ABOVE FLOOR TO CONTROL PANEL.

- 12 COIL AND SECURE WIRES TO CHASSIS WITH 60T
- 11 REMOVE REAR VIEW MIRROR AND MOUNT CAMERA TO CENTER OF WINDSHIELD AND 25 MM BELOW REAR VIEW MIRROR BUTTON. ROUTE CABLE UP ABOVE HEADLINER THEN LEFT DOWN LEFT A-POST COVER TO CENTER DASH TO CONNECT TO WIRE ASM-CHASSIS.
- 10 NOTCH A-POST COVER WHERE IT MEETS THE DASH TO ALLOW DISPLAY CABLE THROUGH. MOUNT DISPLAY TO A-POST COVER AND ADJUST FOR DRIVER'S VIEWING. ROUTE DISPLAY CABLE TO CENTER DASH AND CONNECT TO CAMERA HARNESS.

NOTES:
1. SECURE CONDUIT 41953, TAB AS REQUIRED, OVER ALL WIRES IN CONTACT WITH SHARP EDGES.

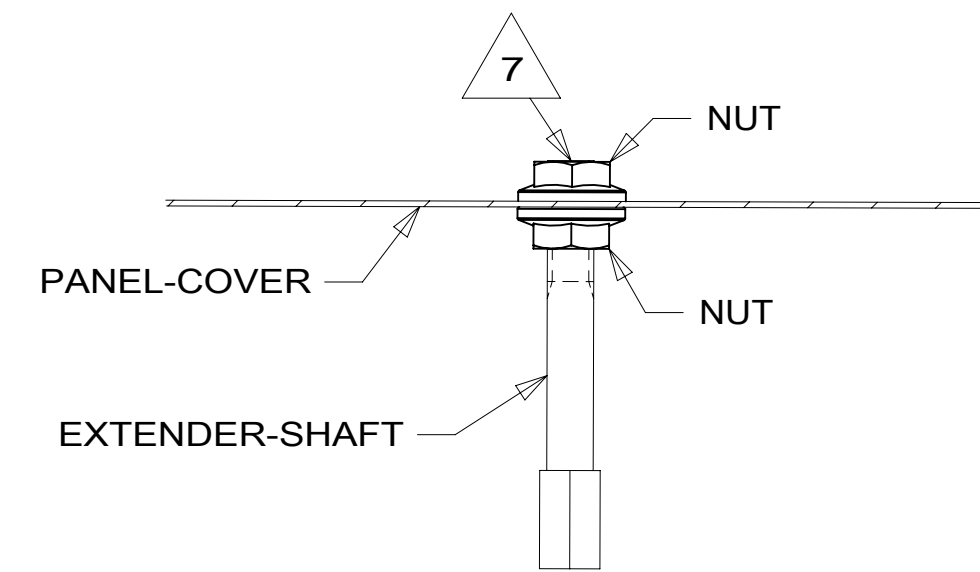

SECTION AC-AC

FOR ELECTRICAL
TORQUE
SPECIFICATIONS
SEE DWG NO.
128783-01-000

FOR ELECTRICAL
CALLOUTS
SEE DWG NO.
121339-01-000

- 60T JACKS-STABILIZING,ELECT W/O
- 64A JACKS-STABILIZING, ELECTRIC
- 36C COLLISION AVOIDANCE SYSTEM
- 52G GEN-3.6KW ONAN LP MICROQUIET
- 33F GEN-3.5 KW ONAN DIESEL
- 265 CODES/STANDARDS-CSA/CMVSS
- 1B1 CODES/STANDARDS USA

WINNEBAGO
COPYRIGHT 2016 WINNEBAGO INDUSTRIES, INC.

DSNR:	ALL DIMENSIONS ARE IN MILLIMETERS
DFFR:	
UNSPECIFIED TOLERANCES:	MATERIAL:
WHOLE DIM (X) : 3	
ONE-PLACE (X.X) : 1.5	
TWO-PLACE (X.XX) : 0.50	
ANGLE : 1°	
REFER TO ES0018 FOR FASTENER TIGHTENING GUIDELINES	WEIGHT: (LBS) FIRST USED: 18 524V
DESCRIPTION: WIRING INSTL-CHASSIS	
SHEET: 1 OF 7	ITEM/PART NO: 000110333 / 32153901000
REF:	REV: 1 02-Jan-2018

8 7 6 5 4 3 2 1

D
C
B
A

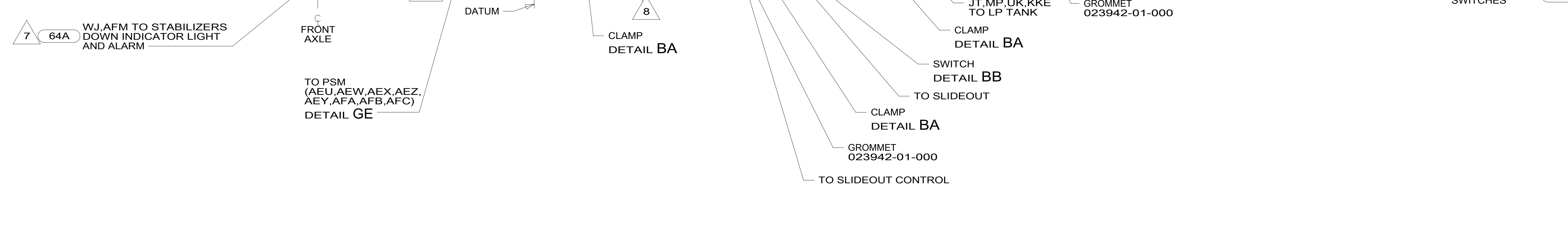
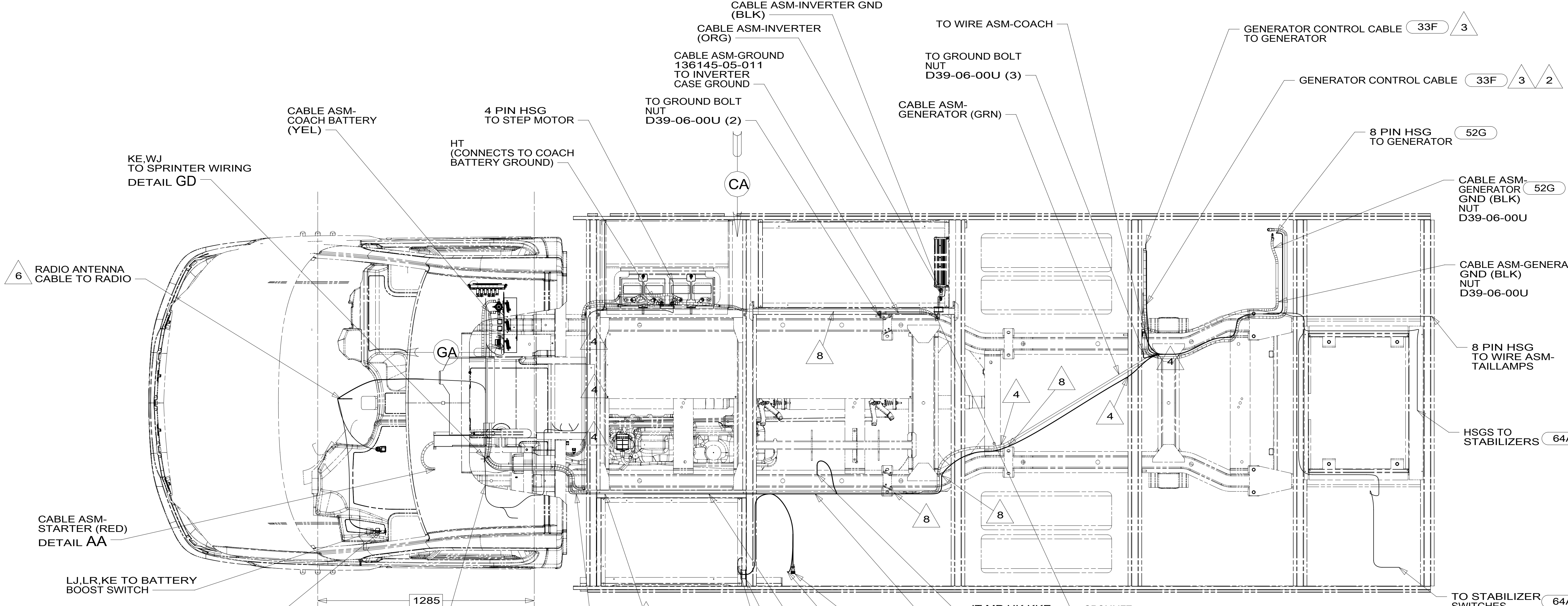

- 8 TIE-WIRE MOUNT 116673-02-000. USE HOLES IN BODY MOUNTS.
- 7 COIL AND SECURE WIRES TO BEHIND DASH PANEL WITH (60T)
- 6 ROUTE WIRES THROUGH CAB FLOOR UNDER DRIVERS SEAT PEDESTAL.
- 5 COIL AND SECURE WIRES TO CHASSIS WITH (60T)
- 4 CLAMP 83610-02-000, SCREW G39-08-12U. DO NOT DRILL OR SCREW INTO SPRINTER FRAME. USE ALUMINUM RISERS.
- 3 WITH FEATURE (33F) CABLE SUPPLIED WITH DIESEL GENERATOR.
- 2 ROUTE GENERATOR CONTROL CABLE ALONG WIRE ASM-CHASSIS THROUGH FLOOR IN THIS AREA.

1. SECURE CONDUIT 41953, TAB AS REQUIRED, OVER ALL WIRES IN CONTACT WITH SHARP EDGES.

NOTES:

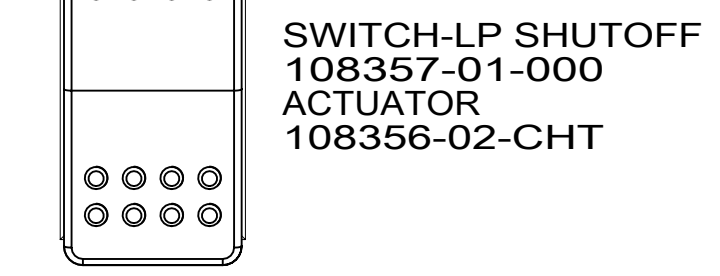

DETAIL BB

FOR ELECTRICAL TORQUE SPECIFICATIONS SEE DWG NO. 128783-01-000

- 64A JACKS-STABILIZING, ELECTRIC
- 60T JACKS-STABILIZING,ELECT W/O
- 52G GEN-3.6KW ONAN LP MICROQUIET
- 33F GEN-3.5 KW ONAN DIESEL
- 265 CODES/STANDARDS-CSA/CMVSS
- 1B1 CODES/STANDARDS USA

FOR ELECTRICAL CALLOUTS SEE DWG NO. 121339-01-000

DESCRIPTION:		WIRING INSTL-CHASSIS	
SHEET:	ITEM/PART NO.:	REV	
2 OF 7	000110333 / 32153901000		
		02-Jan-2018	

8 7 6 5 4 3 2 1

CABLE ASM-STARTER (RED)	141415-37-013
CABLE ASM-COACH BATTERY (YEL)	141415-52-041
CABLE ASM-COACH BATTERY GND (BLK)	133567-12-006
CABLE ASM-GENERATOR (GRN) 321	141415-42-076
CABLE ASM-GENERATOR GND (BLK) 321	133566-12-017
CABLE ASM-GENERATOR (GRN) 33F	141416-42-069
CABLE ASM-GENERATOR GND (BLK) 33F	133567-12-011
CABLE ASM-INVERTOR FUSE (ORG)	141415-62-003
CABLE ASM-INVERTOR (ORG)	141415-62-024
CABLE ASM-INVERTOR GND (BLK)	133566-12-009

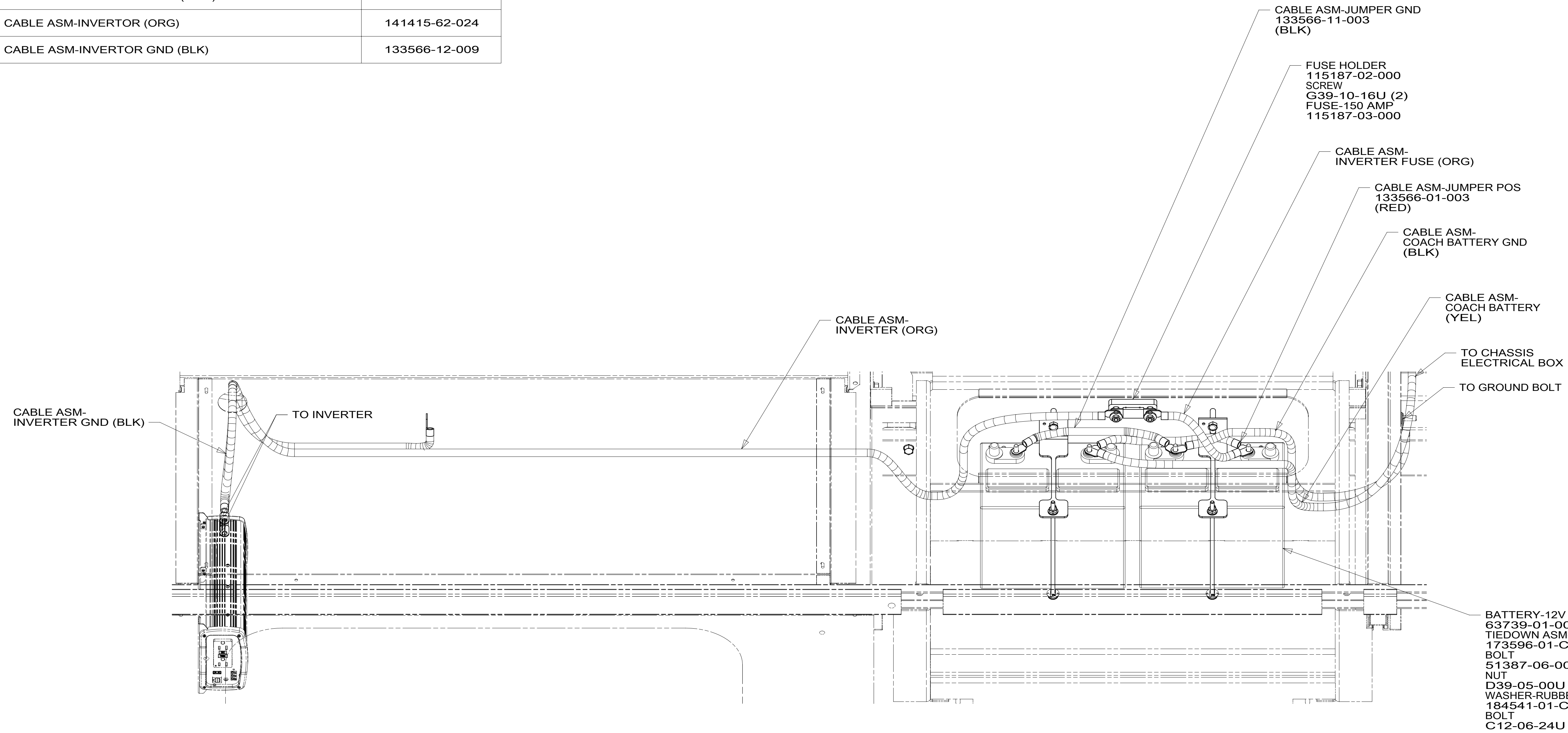

VIEW CA

- 33F GEN-3.2 KW ONAN DIESEL
- 321 GENERATOR PREP KIT
- 265 CODES/STANDARDS-CSA/CMVSS
- 1B1 CODES/STANDARDS USA

- NOTES:
2. BATTERY CABLES ARE NOT TO BE ROUTED OVER BATTERY FILL CAPS.
 1. SECURE CONDUIT 41953, TAB AS REQUIRED, OVER ALL WIRES IN CONTACT WITH SHARP EDGES.

FOR ELECTRICAL TORQUE SPECIFICATIONS SEE DWG NO. 128783-01-000

FOR ELECTRICAL CALLOUTS SEE DWG NO. 121339-01-000

DESCRIPTION:	1B1 265	
WIRING INSTL-CHASSIS		
SHEET:	ITEM/PART NO.:	REV
3 OF 7	000110333 / 32153901000	

8 7 6 5 4 3 2 1

D
C
B
A

PANEL ASM-SOLENOID
194607-01-000
NUT
OMD54U-06-000 (2)

PANEL ASM-CIRCUIT BREAKER
000029754 / 316511-01-000
SCREW-PAN,HEAD
G39-08-08U (6)

PASSENGER SIDE
SEAT PEDESTAL
(REF)

EA

FA

LABEL-FRONT BOX,CRT BKR
098379-01-000

LABEL-ELECTRICAL BOX
098379-04-000

VIEW DA

NOTES:
1. SECURE CONDUIT 41953, TAB AS REQUIRED,
OVER ALL WIRES IN CONTACT WITH SHARP EDGES.

FOR ELECTRICAL
TORQUE
SPECIFICATIONS
SEE DWG NO.
128783-01-000

FOR
ELECTRICAL
CALLOUTS
SEE DWG NO.
121339-01-000

265 CODES/STANDARDS-CSA/CMVSS
1B1 CODES/STANDARDS USA

DESCRIPTION:		1B1	265
WIRING INSTL-CHASSIS			
SHEET:	ITEM/PART NO.:	REV	
4 OF 7	000110333 / 32153901000		

8 7 6 5 4 3 2 1 02-Jan-2018

8 7 6 5 4 3 2 1

D

D

C

C

B

B

A

A

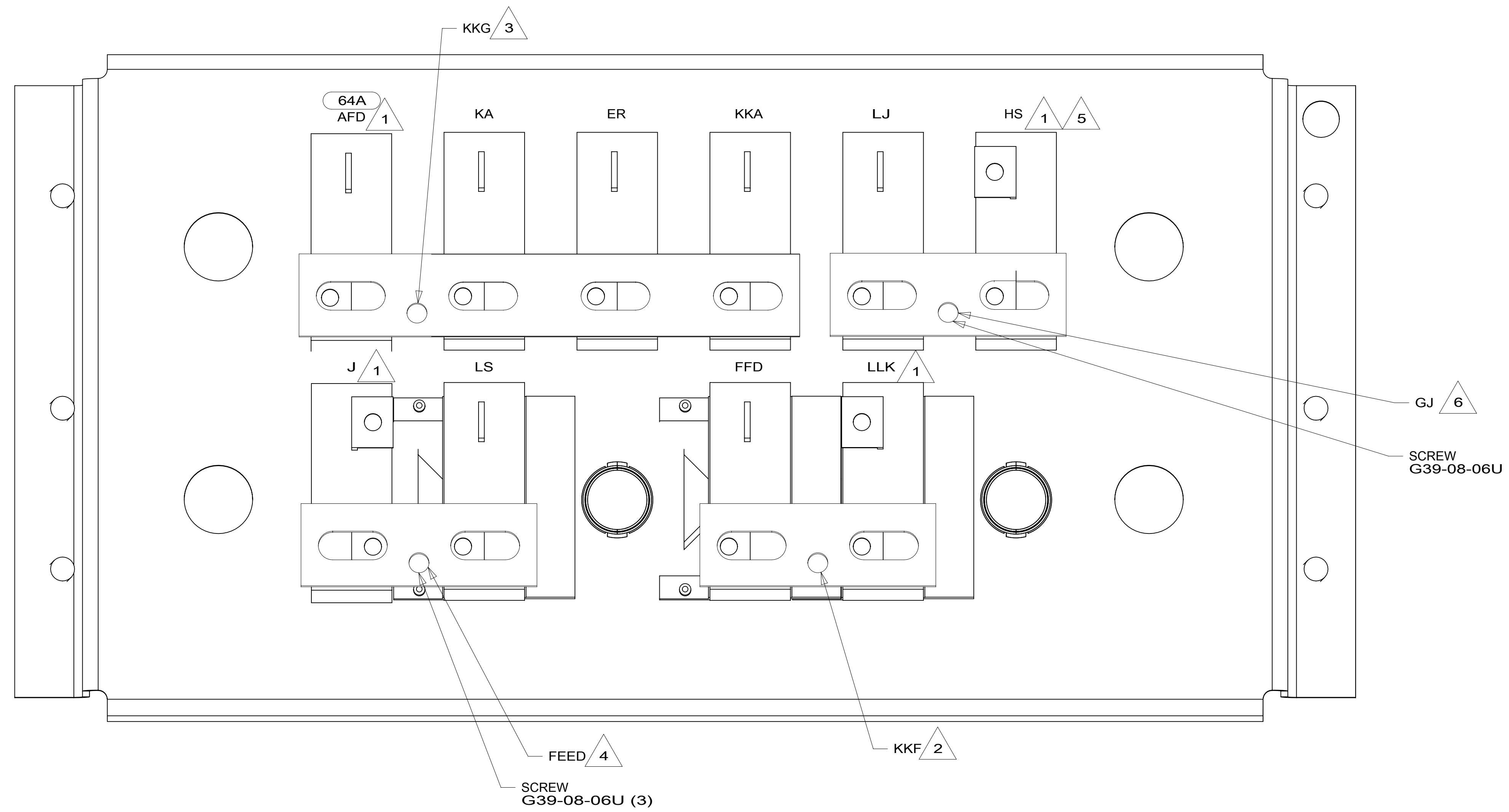

VIEW EA

- NOTES:
- 7. TAPE BACK UNUSED WIRES TO HARNESS.
 - 6 MARKED WITH RED TAPE.
 - 5 MARKED WITH WHITE TAPE.
 - 4 MARKED WITH 2 WRAPS OF YELLOW TAPE.
 - 3 MARKED WITH PURPLE TAPE.
 - 2 MARKED WITH YELLOW TAPE.
 - 1 CIRCUIT FROM WIRE ASM-CHASSIS.

- 64A JACKS-STABILIZING, ELECTRIC
- 265 CODES/STANDARDS-CSA/CMVSS
- 1B1 CODES/STANDARDS USA

FOR ELECTRICAL TORQUE SPECIFICATIONS SEE DWG NO. 128783-01-000

FOR ELECTRICAL CALLOUTS SEE DWG NO. 121339-01-000

DESCRIPTION:	1B1 265	
WIRING INSTL-CHASSIS		
SHEET:	ITEM/PART NO:	REV
5 OF 7	000110333 / 32153901000	

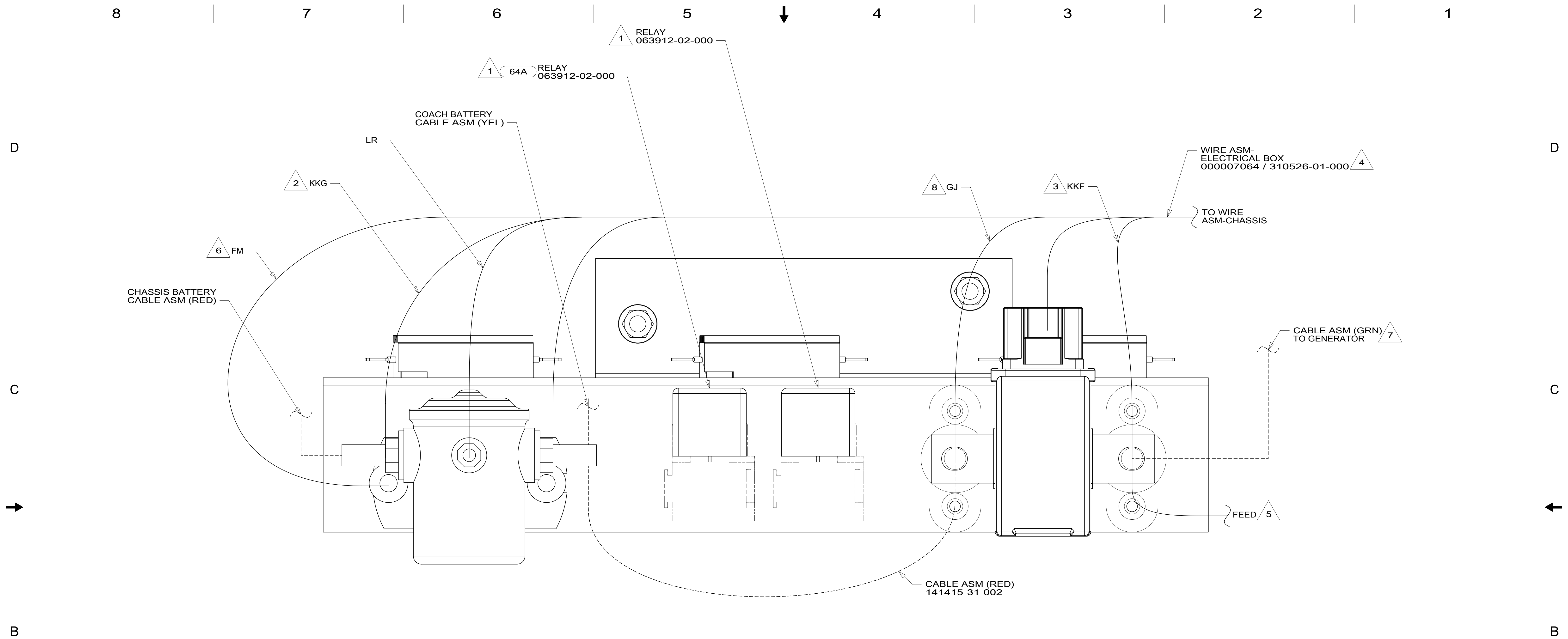

VIEW FA

- NOTES:
- 8 MARKED WITH RED TAPE.
 - 7 WITH FEATURE 321 OR 323 NOT CONNECT CABLE ASM-GENERATOR (GRN) TO SOLENOID. TAPE END WITH TAPE 8363-01-000 AND LEAVE CABLE END LOOSE IN ELECTRICAL BOX.
 - 6 SECURE WITH SOLENOID MOUNTING SCREW.
 - 5 MARKED WITH 2 WRAPS OF YELLOW TAPE.
 - 4 TAPE BACK UNUSED WIRES TO HARNESS.
 - 3 WIRE IS MARKED WITH YELLOW TAPE.
 - 2 WIRE IS MARKED WITH PURPLE TAPE.
 - 1 SEE WIRE ASM-CHASSIS FOR ADDITIONAL INFORMATION.

- 64A JACKS-STABILIZING, ELECTRIC
- 323 GENERATOR PREP KIT - DIESEL
- 321 GENERATOR PREP KIT
- 265 CODES/STANDARDS-CSA/CMVSS
- 1B1 CODES/STANDARDS USA

FOR ELECTRICAL TORQUE SPECIFICATIONS SEE DWG NO. 128783-01-000

FOR ELECTRICAL CALLOUTS SEE DWG NO. 121339-01-000

DESCRIPTION:	1B1 265	
WIRING INSTL-CHASSIS		
SHEET:	ITEM/PART NO:	REV
6 OF 7	000110333 / 32153901000	

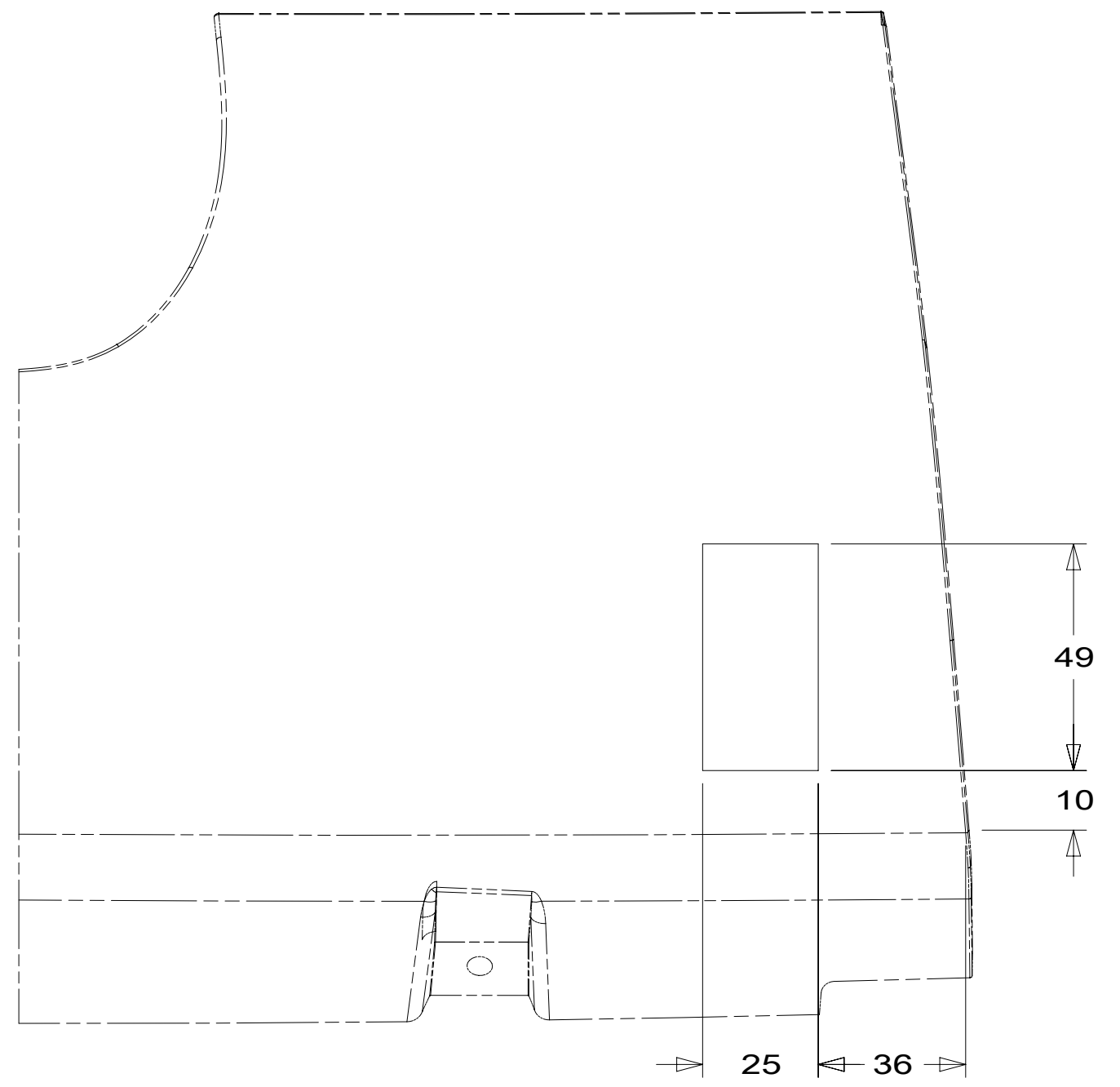

DETAIL GB 5

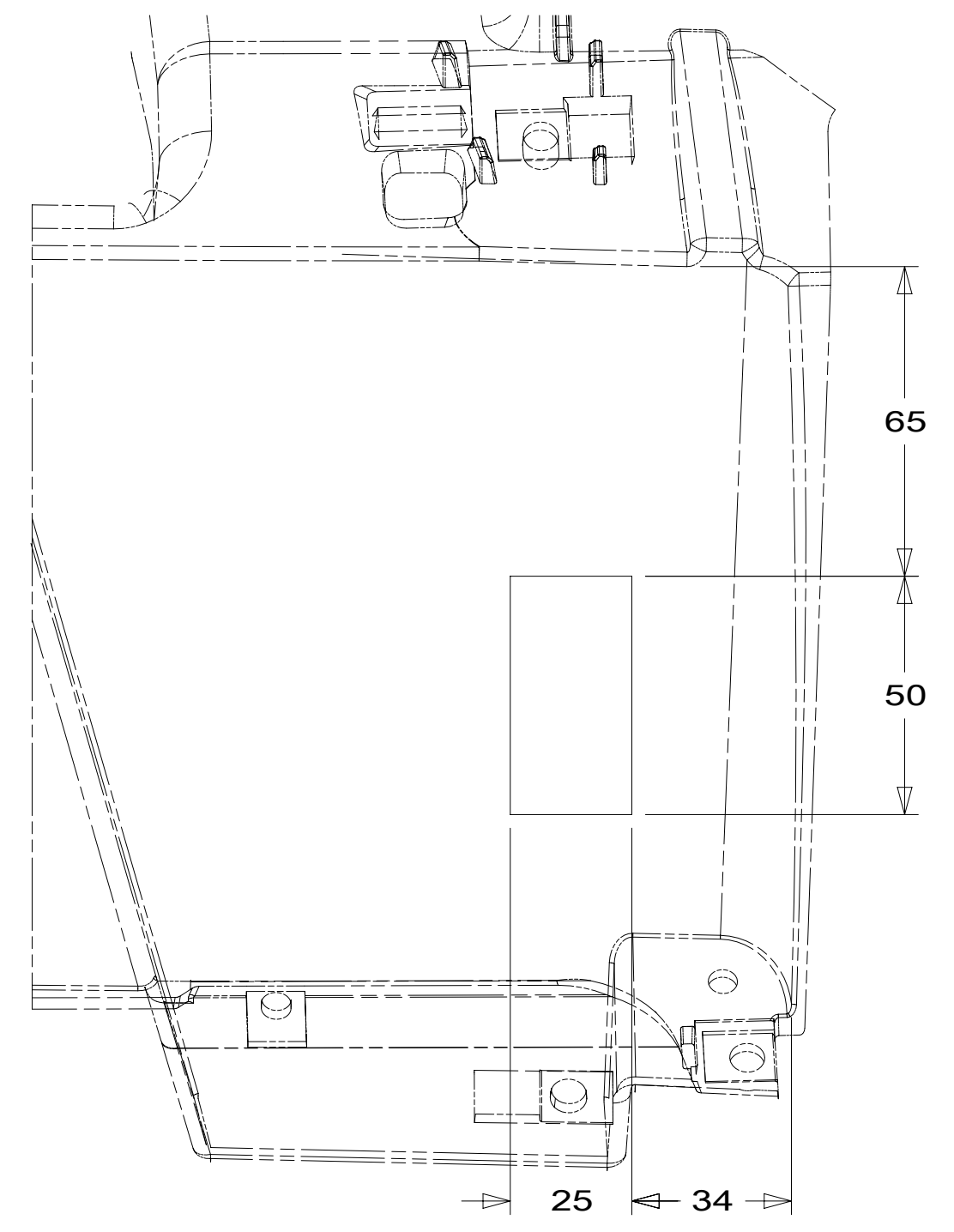

VIEW GC 6

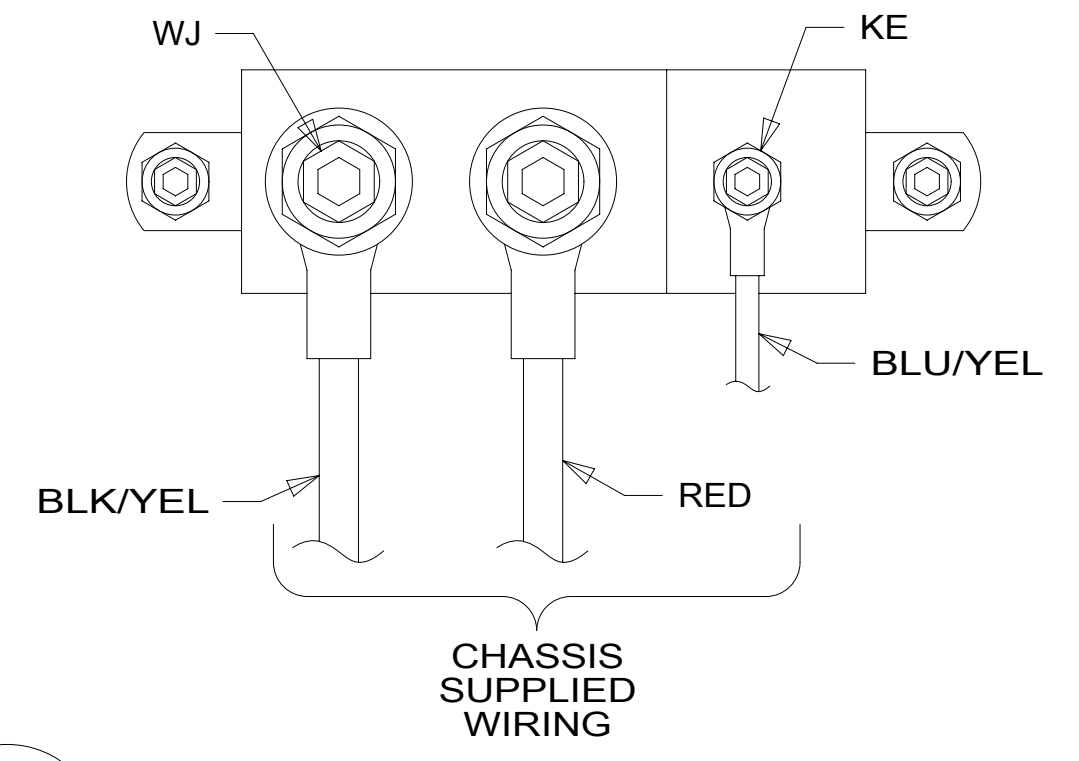

DETAIL GD 3

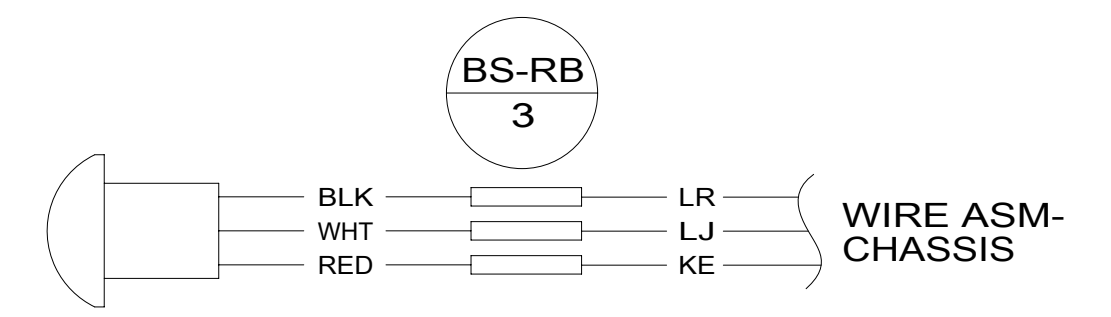

DETAIL GF

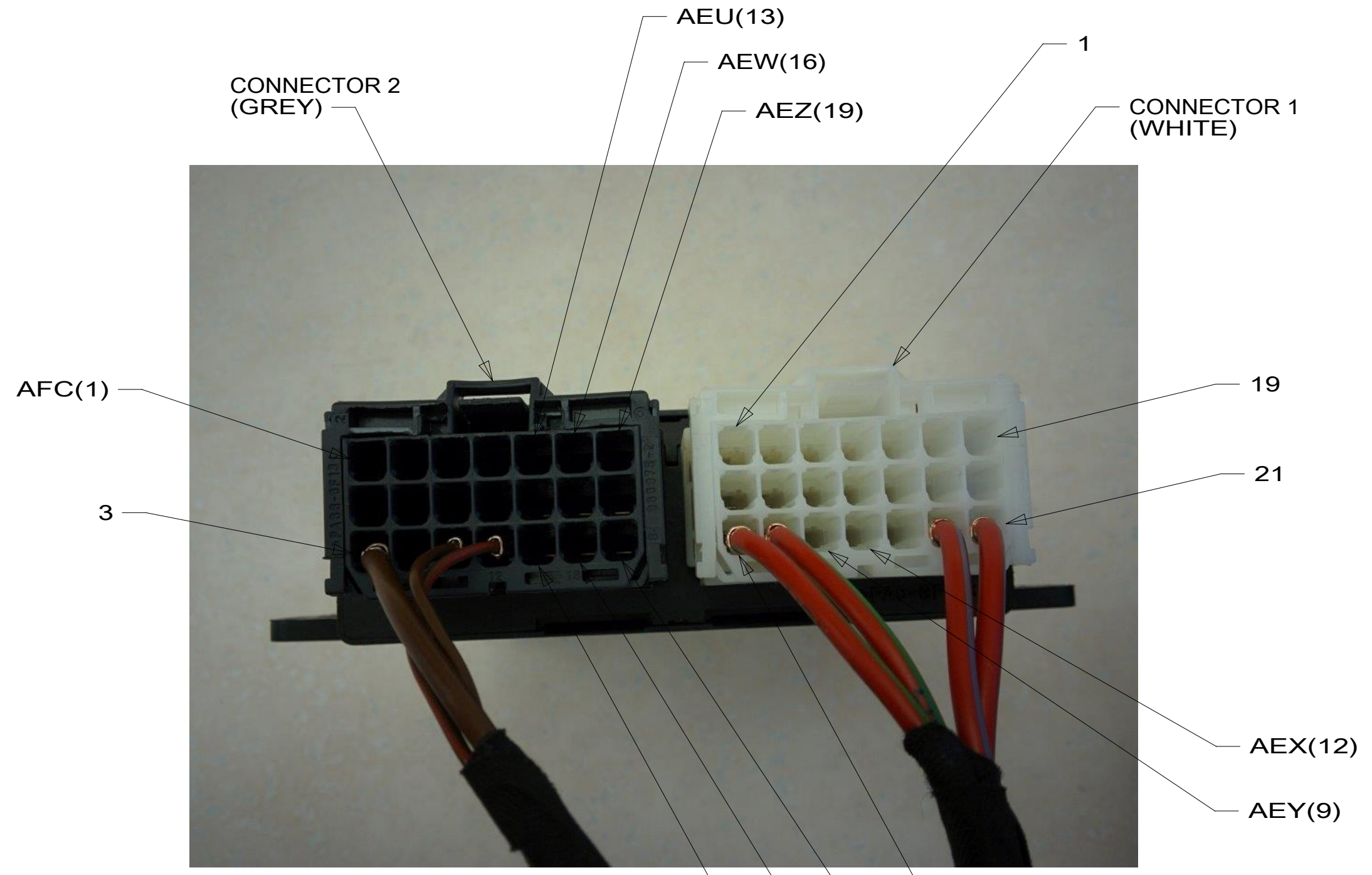

DETAIL GE 1

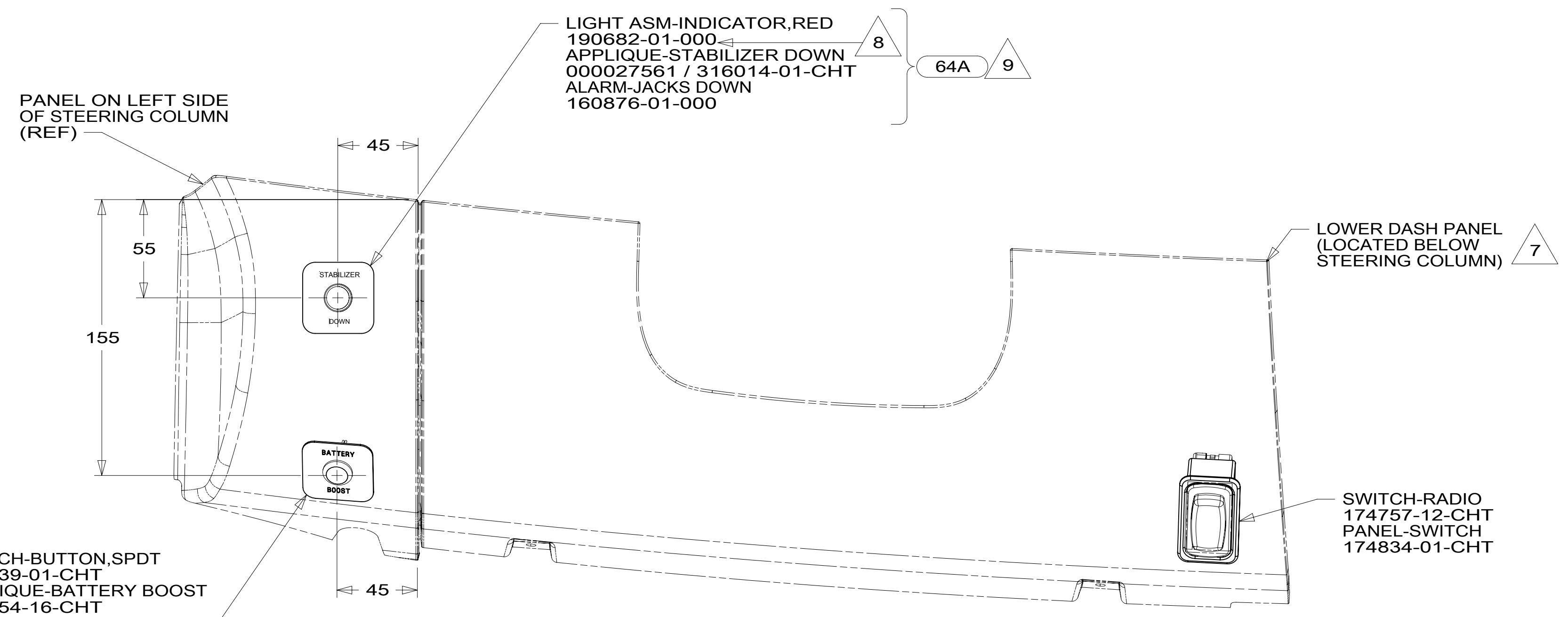

VIEW GA

- NOTES:
- 6 DASH STRUCTURE LOCATED BEHIND LOWER DASH PANEL.
 - 5 LOWER DASH PANEL.
 - 4 DRILL 12.3 MM HOLE INTO DASH PANEL.
 - 3 CONNECTION POINT IS LOCATED UNDER DRIVERS SEAT.
 - 2. SECURE CONDUIT 41953, TAB AS REQUIRED, OVER ALL WIRES IN CONTACT WITH SHARP EDGES.
 - 1 PSM IS LOCATED UNDER DRIVERS SEAT.

- 9 CONNECT YELLOW WIRES TO MARKED TERMINAL ON THE ALARM AND LIGHT. KEEP LIKE TERMINALS TOGETHER. USE 008343-01-000 TO SECURE ALARM BACK TO LOOM.
- 8 DRILL A 1/2 INCH HOLE AT DIMENSIONS SHOWN TO INSERT LIGHT. DISCARD RUBBER GASKET THAT COMES WITH LIGHT AND INSTALL LIGHT INTO HOLE.
- 7 FOR CUTOUT DIMENSIONS SEE DETAIL GB AND DETAIL GC.

FOR ELECTRICAL TORQUE SPECIFICATIONS SEE DWG NO. 128783-01-000

FOR ELECTRICAL CALLOUTS SEE DWG NO. 121339-01-000

- 64A JACKS-STABILIZING, ELECTRIC
- 265 CODES/STANDARDS-CSA/CMVSS
- 1B1 CODES/STANDARDS USA

DESCRIPTION: WIRING INSTL-CHASSIS		
SHEET: 7 OF 7	ITEM/PART NO: 000110333 / 32153901000	REV