

VIEW AB 9

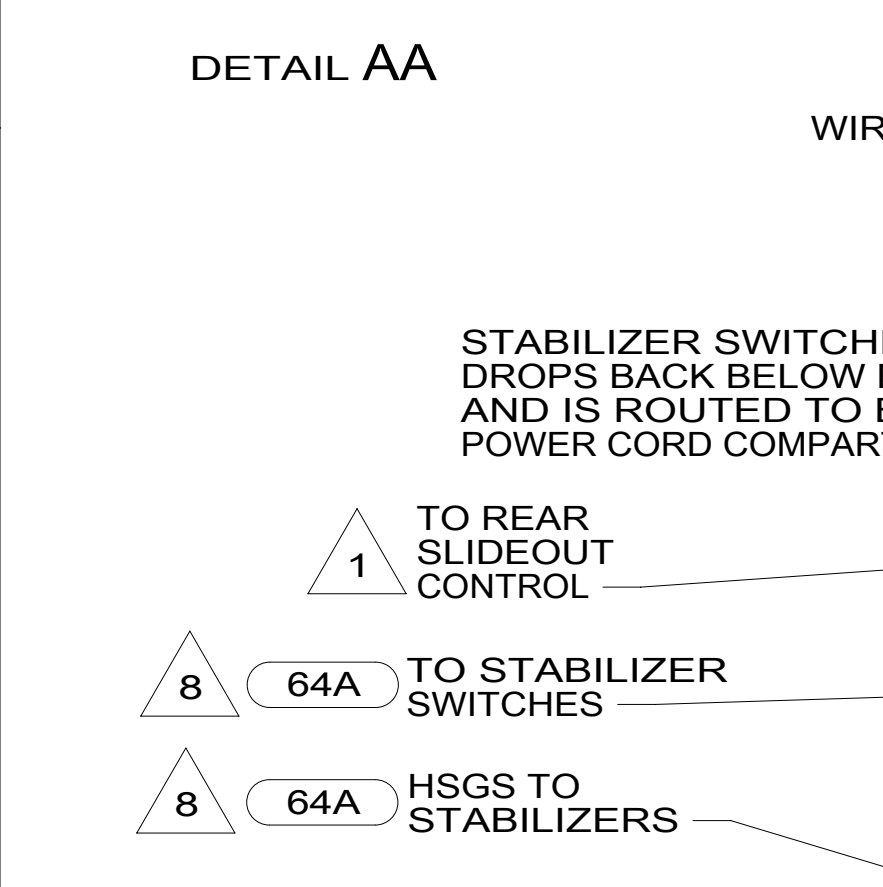

SECTION AC-AC

- NOTES:
- 1 SEE WIRING INSTL-BODY, 12V FOR ADDITIONAL INFORMATION.
 - 2 SECURE CONDUIT 41953, TAB AS REQUIRED, OVER ALL WIRES IN CONTACT WITH SHARP EDGES.
 - 3 CUT WIRE TIE AROUND SPRINTER SEAL, ROUTE THE CHASSIS WIRING THROUGH HOLE AND WIRE TIE SEAL WITH WIRE TIE 8343-04-000.
 - 4 SEE SHEET 3 FOR ADDITIONAL INFORMATION.
 - 5 CABLE SUPPLIED WITH DIESEL GENERATOR.
 - 6 CONNECT YELLOW WIRES TO MARKED TERMINAL ON THE ALARM AND LIGHT. KEEP LIKE TERMINALS TOGETHER. USE 008343-01-000 TO SECURE ALARM BACK TO LOOM.
 - 7 12 PIN HOUSING TO BE ROUTED ABOVE FLOOR TO CONTROL PANEL.
 - 8 COIL AND SECURE WIRES WITH 60T
 - 9 REMOVE PLASTIC TRAY AND DISCARD.

- 10 CONNECT THE TWO 15 PIN HSGS TOGETHER WITHOUT 57P
- 11 NOTCH A-POST COVER WHERE IT MEETS THE DASH TO ALLOW DISPLAY CABLE THROUGH. MOUNT DISPLAY TO A-POST COVER AND ADJUST FOR DRIVER'S VIEWING. ROUTE DISPLAY CABLE TO CENTER DASH AND CONNECT TO CAMERA HARNESS.
- 12 REMOVE REAR VIEW MIRROR AND MOUNT CAMERA TO CENTER OF WINDSHIELD AND 25 MM BELOW REAR VIEW MIRROR BUTTON. ROUTE CABLE UP ABOVE HEADLINER THEN LEFT DOWN LEFT A-POST TO CENTER DASH TO CONNECT TO WIRE ASM-CHASSIS.
- 13 INSTALL NUT SO THAT IT IS FLUSH WITH TOP OF EXTENDER-SHAFT.

- 64A JACKS-STABILIZING, ELECTRIC
- 60T JACKS-STABILIZING,ELECT W/O
- 36C COLLISION AVOIDANCE SYSTEM
- 57P RADIO SPEAKERS-PREMIUM SOUND
- 33F GEN-3.5 KW ONAN DIESEL
- 52G GEN-3.6KW ONAN LP MICROQUIET
- 265 CODES/STANDARDS-CSA/CMVSS
- 1B1 CODES/STANDARDS USA

1B1 265

WINNEBAGO
COPYRIGHT 2016 WINNEBAGO INDUSTRIES, INC.

DSNR:	ALL DIMENSIONS ARE IN MILLIMETERS
DIFFR:	
UNSPECIFIED TOLERANCES:	MATERIAL:
WHOLE DIM (X) : 3	
ONE-PLACE (X.X) : 1.5	
TWO-PLACE (X.XX) : 0.50	
ANGLE : 1°	
REFER TO ES0018 FOR FASTENER TIGHTENING GUIDELINES	WEIGHT: (LBS) FIRST USED:
	18 524G
DESCRIPTION: WIRING INSTL-CHASSIS	
SHEET: 1 OF 7	ITEM/PART NO: 000045205 / 32085501000
REF:	1 13-Dec-2017

FOR ELECTRICAL TORQUE SPECIFICATIONS SEE DWG NO. 128783-01-000

X-X FOR ELECTRICAL CALLOUTS SEE DWG NO. 121339-01-000

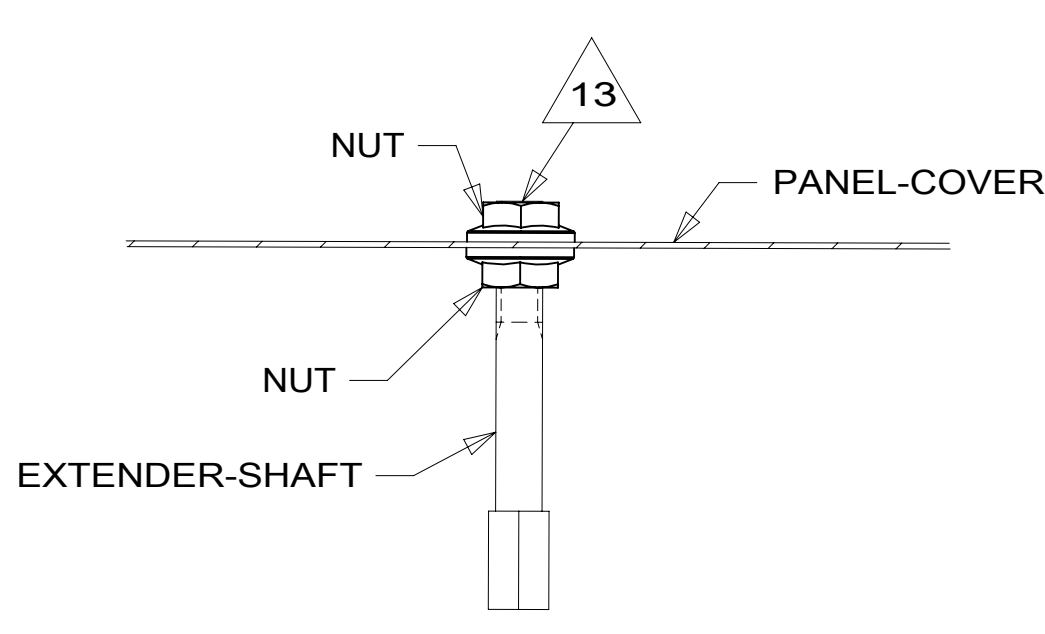

SECTION AC-AC

CABLE ASM-STARTER (RED)	141415-37-013
CABLE ASM-COACH BATTERY (YEL)	141415-52-041
CABLE ASM-COACH BATTERY GND (BLK)	133567-12-006
CABLE ASM-GENERATOR (GRN) (321)	141415-42-076
CABLE ASM-GENERATOR GND (BLK) (321)	133566-12-017
CABLE ASM-GENERATOR (GRN) (33F)	141416-42-069
CABLE ASM-GENERATOR GND (BLK) (33F)	133567-12-011
CABLE ASM-INVERTOR FUSE (ORG)	141415-62-003
CABLE ASM-INVERTOR (ORG)	141415-62-024
CABLE ASM-INVERTOR GND (BLK)	133566-12-009

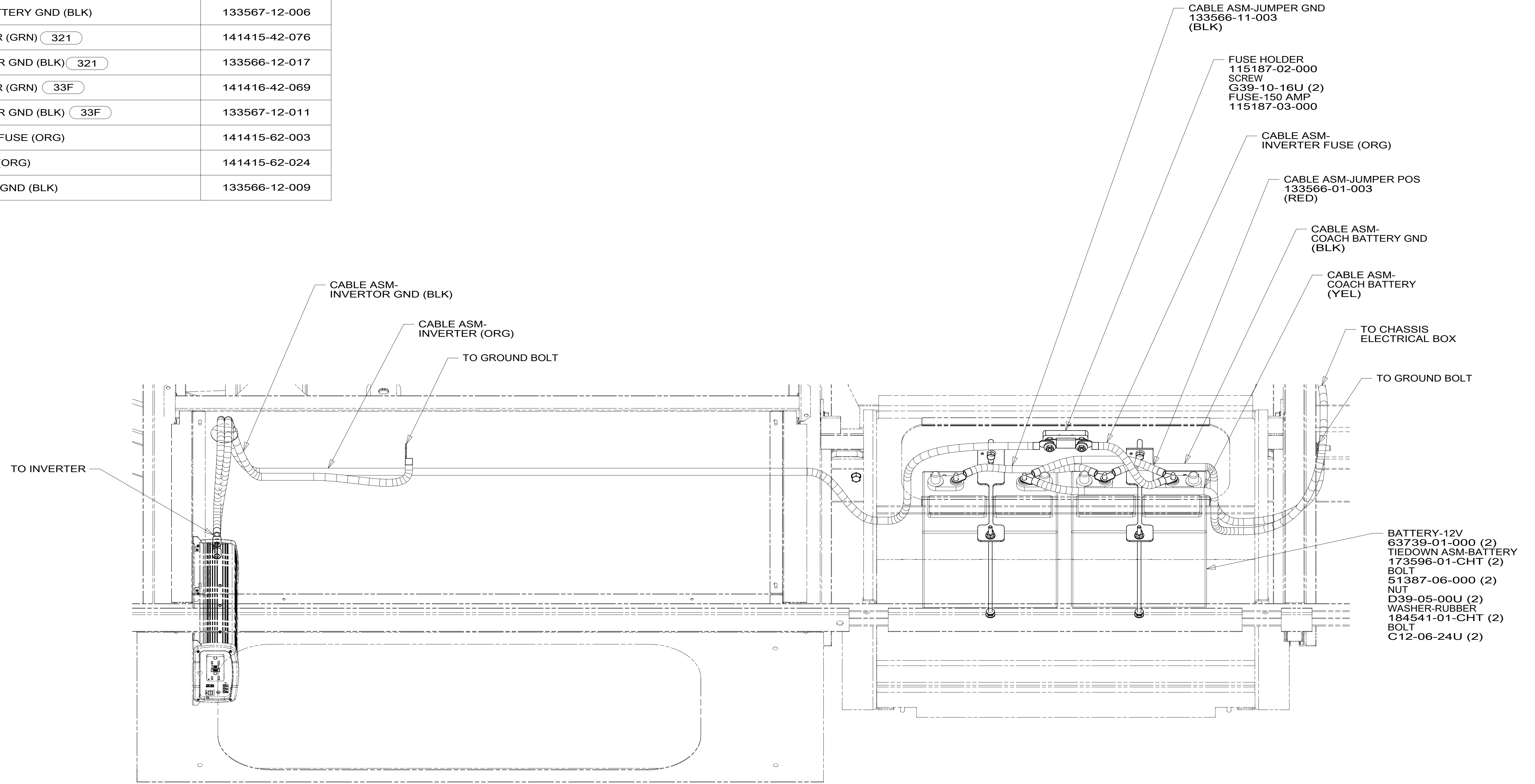

VIEW CA

- (33F) GEN-3.2 KW ONAN DIESEL
- (321) GENERATOR PREP KIT
- (265) CODES/STANDARDS-CSA/CMVSS
- (1B1) CODES/STANDARDS USA

NOTES:
 2. BATTERY CABLES ARE NOT TO BE ROUTED OVER BATTERY FILL CAPS.
 1. SECURE CONDUIT 41953, TAB AS REQUIRED, OVER ALL WIRES IN CONTACT WITH SHARP EDGES.

FOR ELECTRICAL TORQUE SPECIFICATIONS SEE DWG NO. 128783-01-000

(X-X) FOR ELECTRICAL CALLOUTS SEE DWG NO. 121339-01-000

(1B1)	(265)
DESCRIPTION: WIRING INSTL-CHASSIS	
SHEET: 3 OF 7	ITEM/PART NO: 000045205 / 32085501000
REV 13-Dec-2017	

8 7 6 5 4 3 2 1

D
C
B
A

PANEL ASM-SOLENOID
194607-01-000
NUT
OMD54U-06-000 (2)

PANEL ASM-CIRCUIT BREAKER
000045493 / 320948-01-000
SCREW-PAN_HEAD
G39-08-08U (6)

PASSENGER SIDE
SEAT PEDESTAL
(REF)

LABEL
098379-01-000

LABEL
098379-04-000

VIEW DA

NOTES:
1. SECURE CONDUIT 41953, TAB AS REQUIRED,
OVER ALL WIRES IN CONTACT WITH SHARP EDGES.

FOR ELECTRICAL
TORQUE
SPECIFICATIONS
SEE DWG NO.
128783-01-000

FOR ELECTRICAL
CALLOUTS
SEE DWG NO.
121339-01-000

265 CODES/STANDARDS-CSA/CMVSS
1B1 CODES/STANDARDS USA

DESCRIPTION:		1B1	265
WIRING INSTL-CHASSIS			
SHEET:	ITEM/PART NO.:	REV	
4 OF 7	000045205 / 32085501000		

8 7 6 5 4 3 2 1 13-Dec-2017

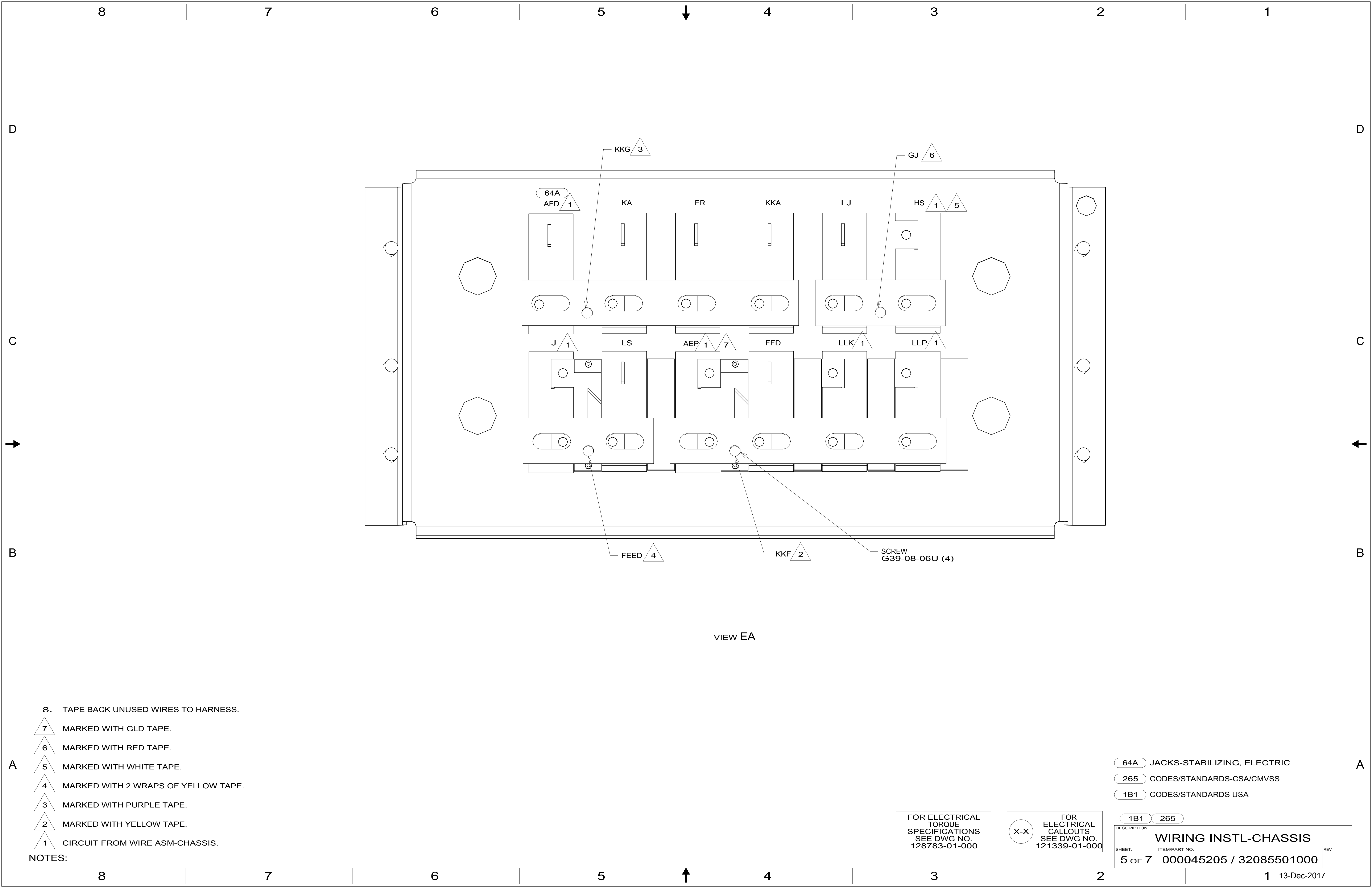

VIEW EA

- NOTES:
- 8. TAPE BACK UNUSED WIRES TO HARNESS.
 - 7 MARKED WITH GLD TAPE.
 - 6 MARKED WITH RED TAPE.
 - 5 MARKED WITH WHITE TAPE.
 - 4 MARKED WITH 2 WRAPS OF YELLOW TAPE.
 - 3 MARKED WITH PURPLE TAPE.
 - 2 MARKED WITH YELLOW TAPE.
 - 1 CIRCUIT FROM WIRE ASM-CHASSIS.

- 64A JACKS-STABILIZING, ELECTRIC
- 265 CODES/STANDARDS-CSA/CMVSS
- 1B1 CODES/STANDARDS USA

FOR ELECTRICAL TORQUE SPECIFICATIONS SEE DWG NO. 128783-01-000

FOR ELECTRICAL CALLOUTS SEE DWG NO. 121339-01-000

DESCRIPTION:		1B1 265	
WIRING INSTL-CHASSIS			
SHEET:	ITEM/PART NO.:	REV	
5 OF 7	000045205 / 32085501000		

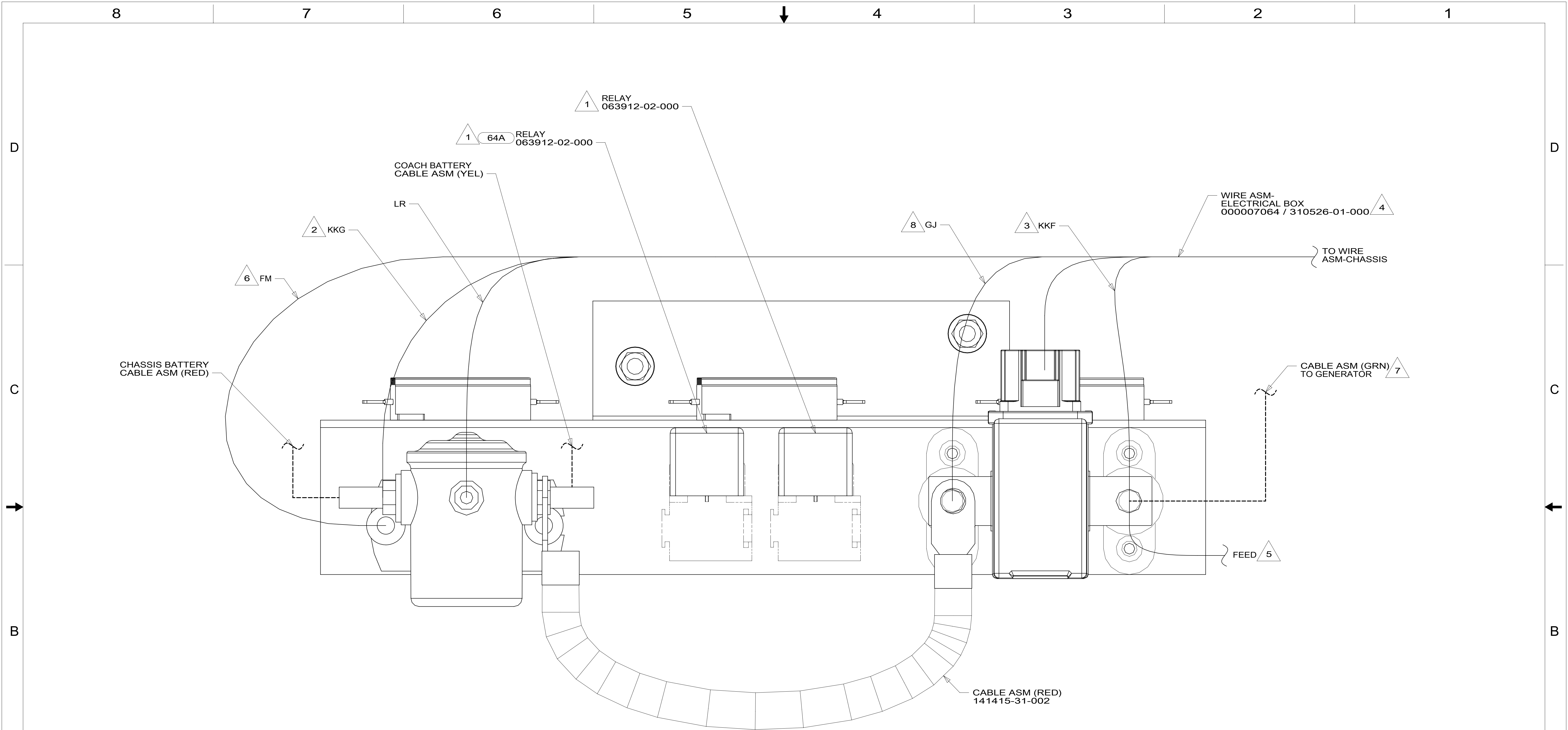

VIEW FA

- 8 MARKED WITH RED TAPE.
- 7 WITH FEATURE 321 OR 323 NOT CONNECT CABLE ASM-GENERATOR (GRN) TO SOLENOID. TAPE END WITH TAPE 8363-01-000 AND LEAVE CABLE END LOOSE IN ELECTRICAL BOX.
- 6 SECURE WITH SOLENOID MOUNTING SCREW.
- 5 MARKED WITH 2 WRAPS OF YELLOW TAPE.
- 4 TAPE BACK UNUSED WIRES TO HARNESS.
- 3 WIRE IS MARKED WITH YELLOW TAPE.
- 2 WIRE IS MARKED WITH PURPLE TAPE.
- 1 SEE WIRE ASM-CHASSIS FOR ADDITIONAL INFORMATION.

NOTES:

- 64A JACKS-STABILIZING, ELECTRIC
- 323 GENERATOR PREP KIT - DIESEL
- 321 GENERATOR PREP KIT
- 265 CODES/STANDARDS-CSA/CMVSS
- 1B1 CODES/STANDARDS USA

FOR ELECTRICAL TORQUE SPECIFICATIONS SEE DWG NO. 128783-01-000

X-X FOR ELECTRICAL CALLOUTS SEE DWG NO. 121339-01-000

DESCRIPTION:		1B1 265	
WIRING INSTL-CHASSIS			
SHEET:	ITEM/PART NO.:	REV	
6 OF 7	000045205 / 32085501000		

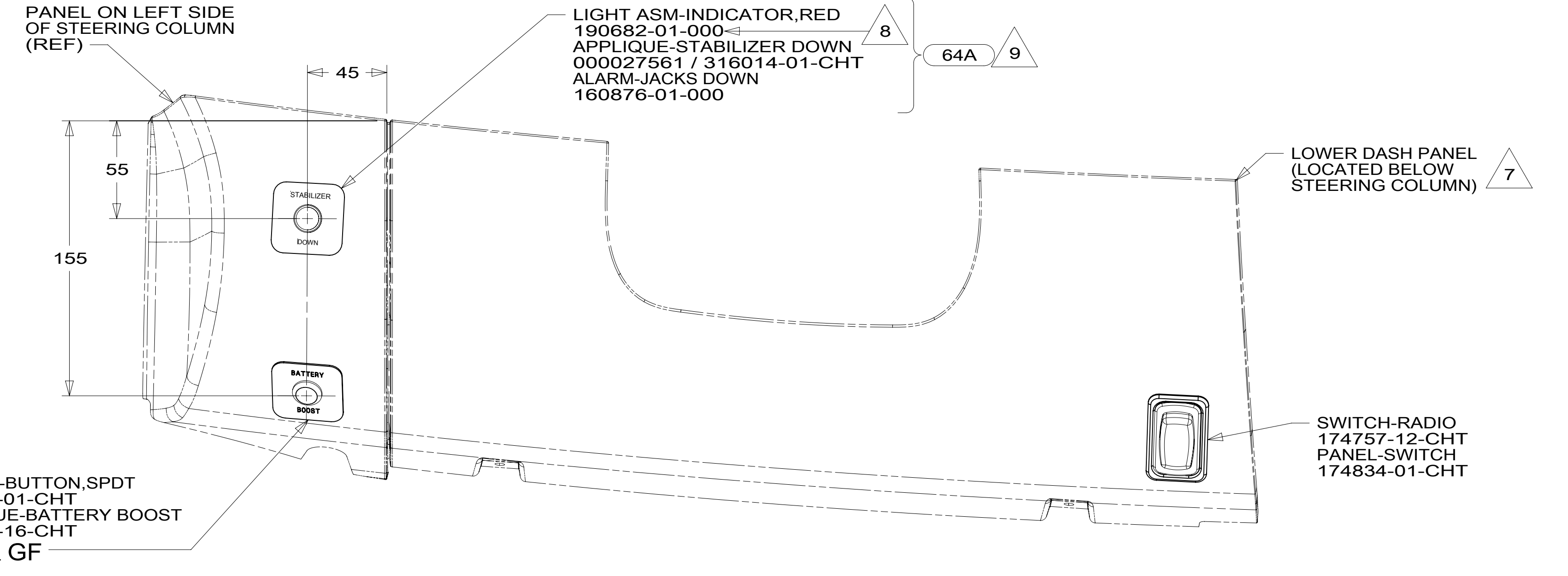
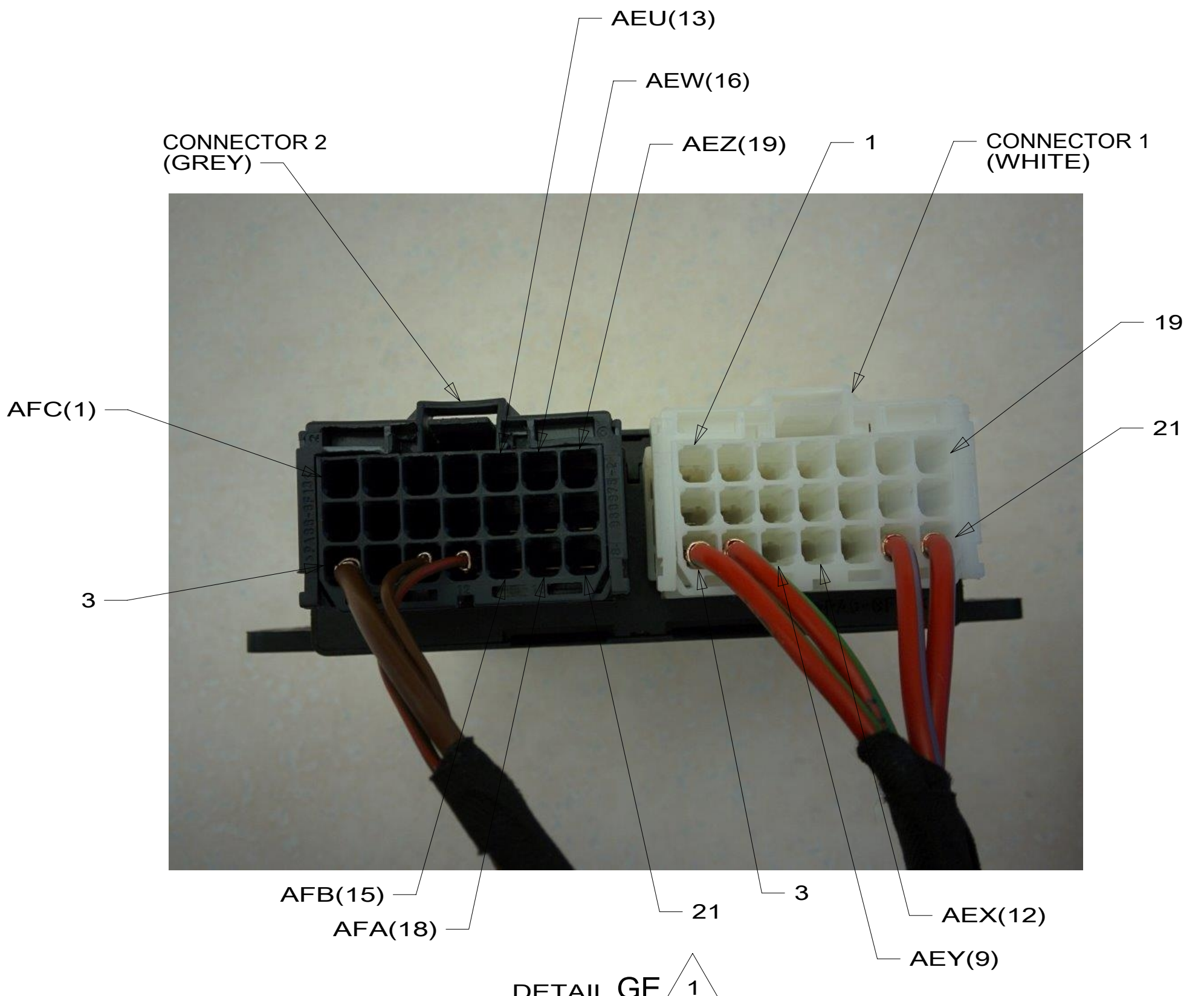
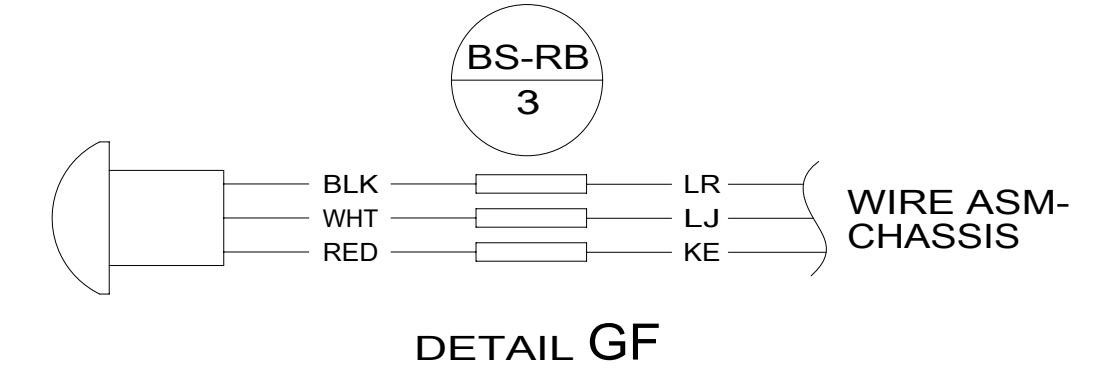
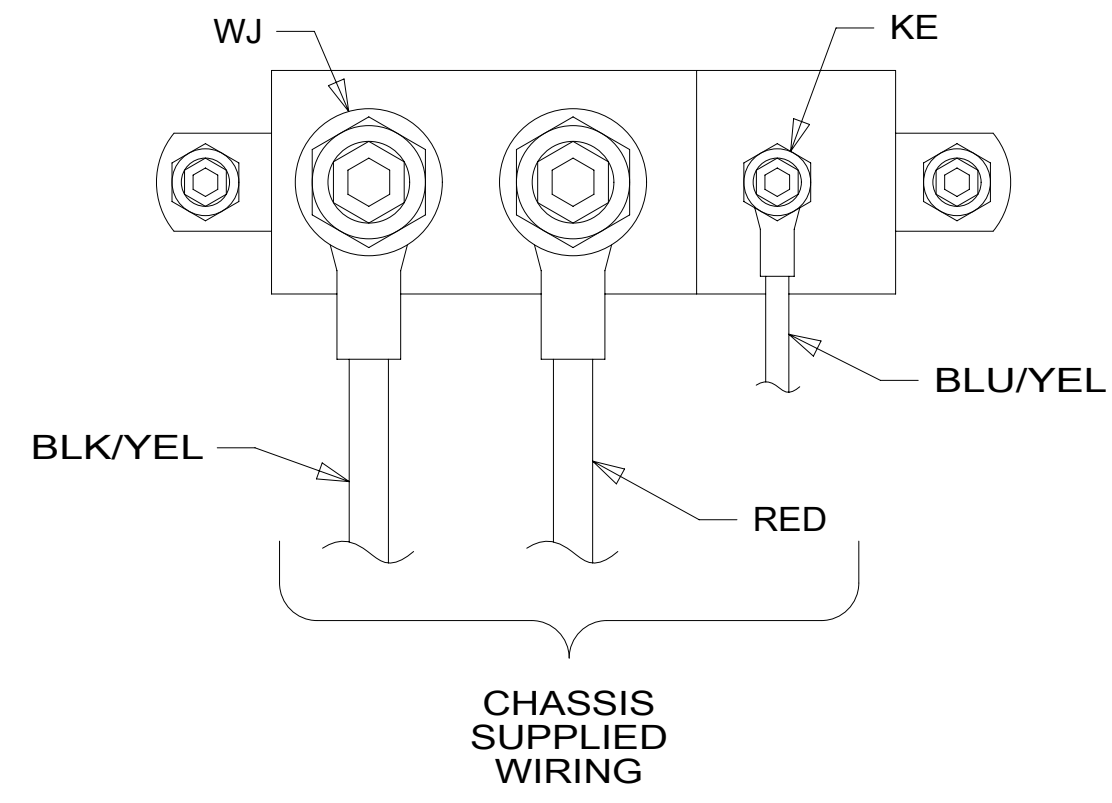
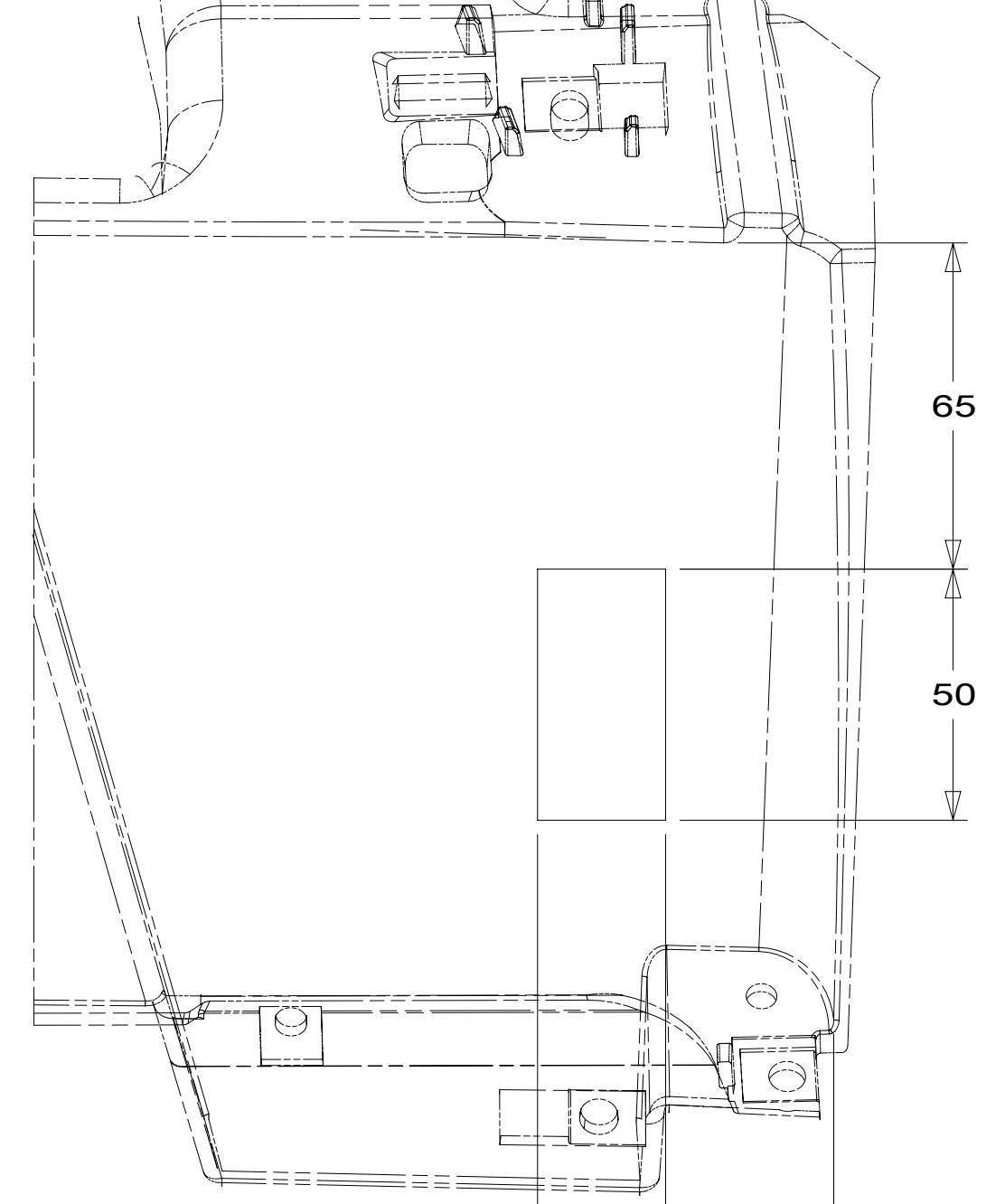
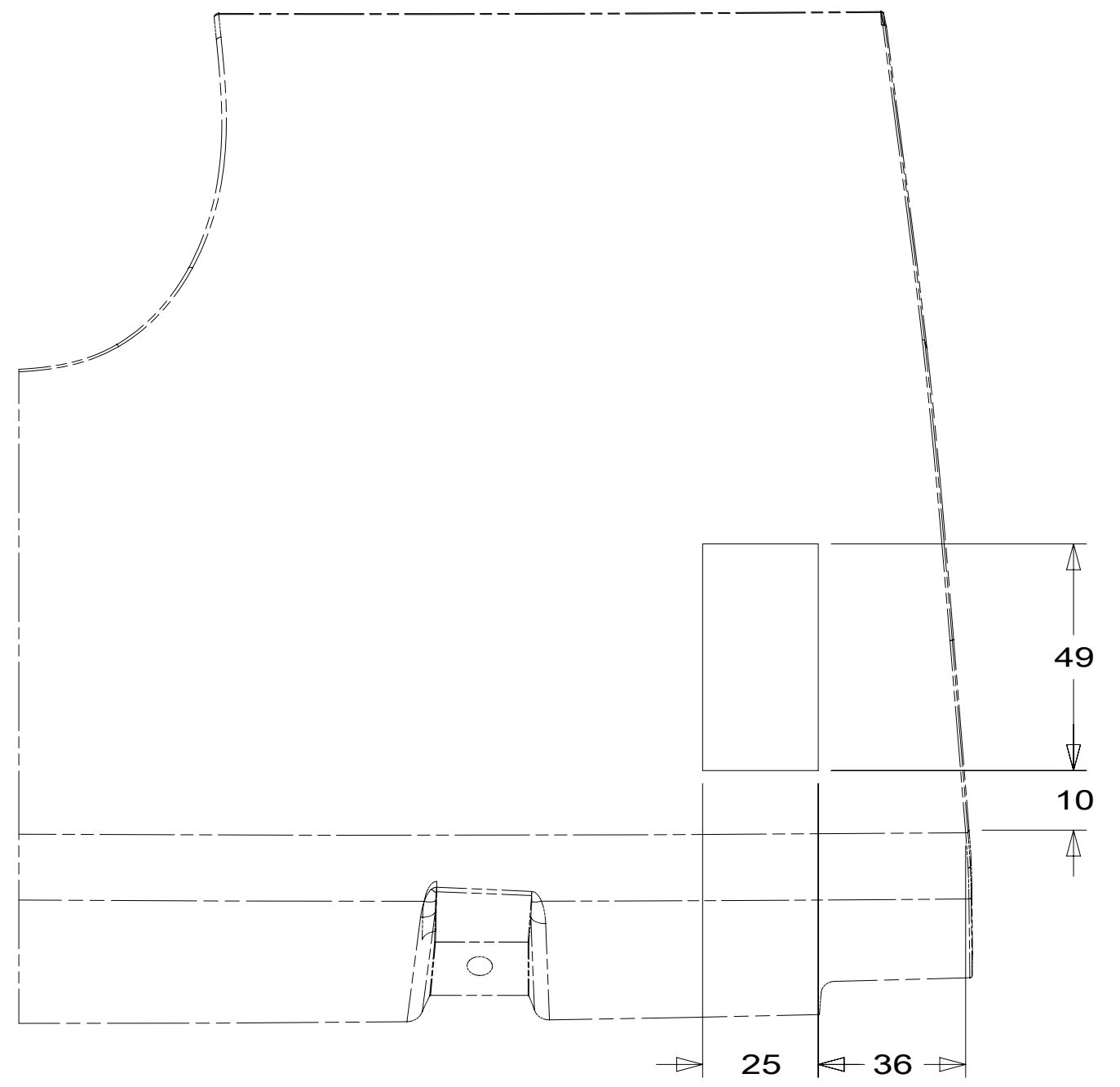

- NOTES:
- 6 DASH STRUCTURE LOCATED BEHIND LOWER DASH PANEL.
 - 5 LOWER DASH PANEL.
 - 4 DRILL 12.3 MM HOLE INTO DASH PANEL.
 - 3 CONNECTION POINT IS LOCATED UNDER DRIVERS SEAT.
 - 2. SECURE CONDUIT 41953, TAB AS REQUIRED, OVER ALL WIRES IN CONTACT WITH SHARP EDGES.
 - 1 PSM IS LOCATED UNDER DRIVERS SEAT.

- 9 CONNECT YELLOW WIRES TO MARKED TERMINAL ON THE ALARM AND LIGHT. KEEP LIKE TERMINALS TOGETHER. USE 008343-01-000 TO SECURE ALARM BACK TO LOOM.
- 8 DRILL A 1/2 INCH HOLE AT DIMENSIONS SHOWN TO INSERT LIGHT. DISCARD RUBBER GASKET THAT COMES WITH LIGHT AND INSTALL LIGHT INTO HOLE.
- 7 FOR CUTOUT DIMENSIONS SEE DETAIL GB AND DETAIL GC.

FOR ELECTRICAL TORQUE SPECIFICATIONS SEE DWG NO. 128783-01-000

FOR ELECTRICAL CALLOUTS SEE DWG NO. 121339-01-000

- 64A JACKS-STABILIZING, ELECTRIC
- 265 CODES/STANDARDS-CSA/CMVSS
- 1B1 CODES/STANDARDS USA

DESCRIPTION: WIRING INSTL-CHASSIS		
SHEET: 7 OF 7	ITEM/PART NO: 000045205 / 32085501000	REV