

8 7 6 5 4 3 2 1

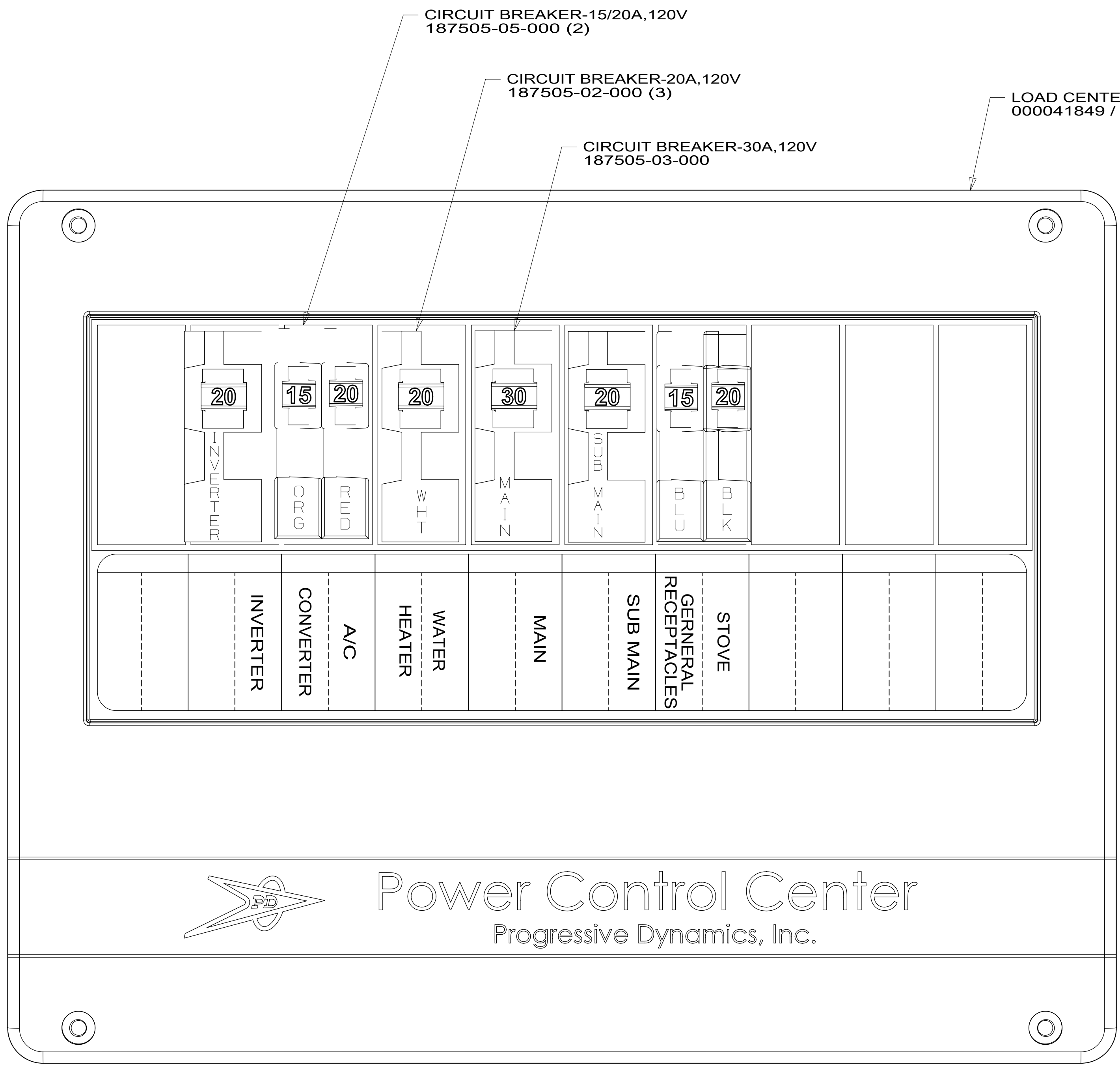

FRONT VIEW

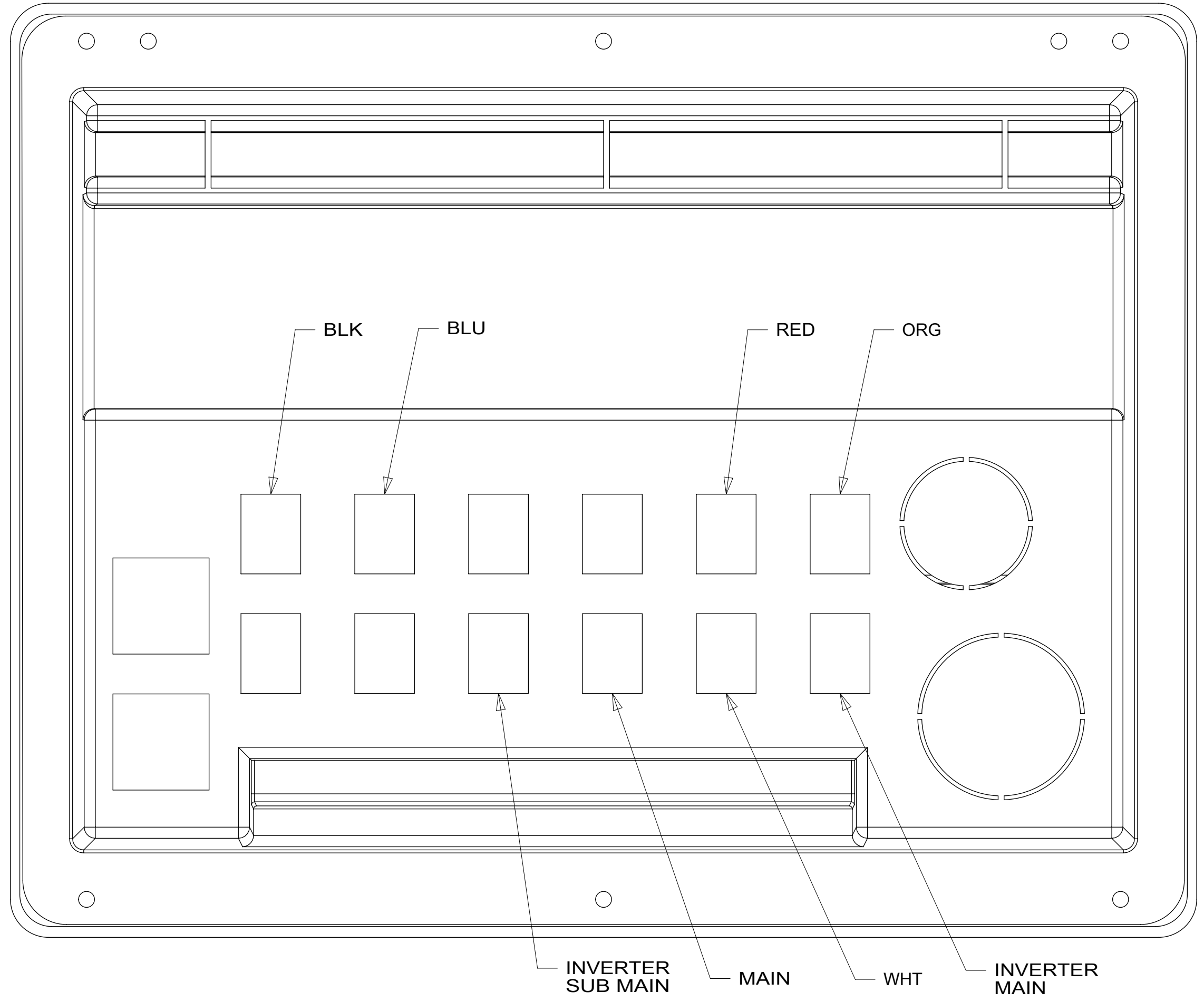

BACK VIEW

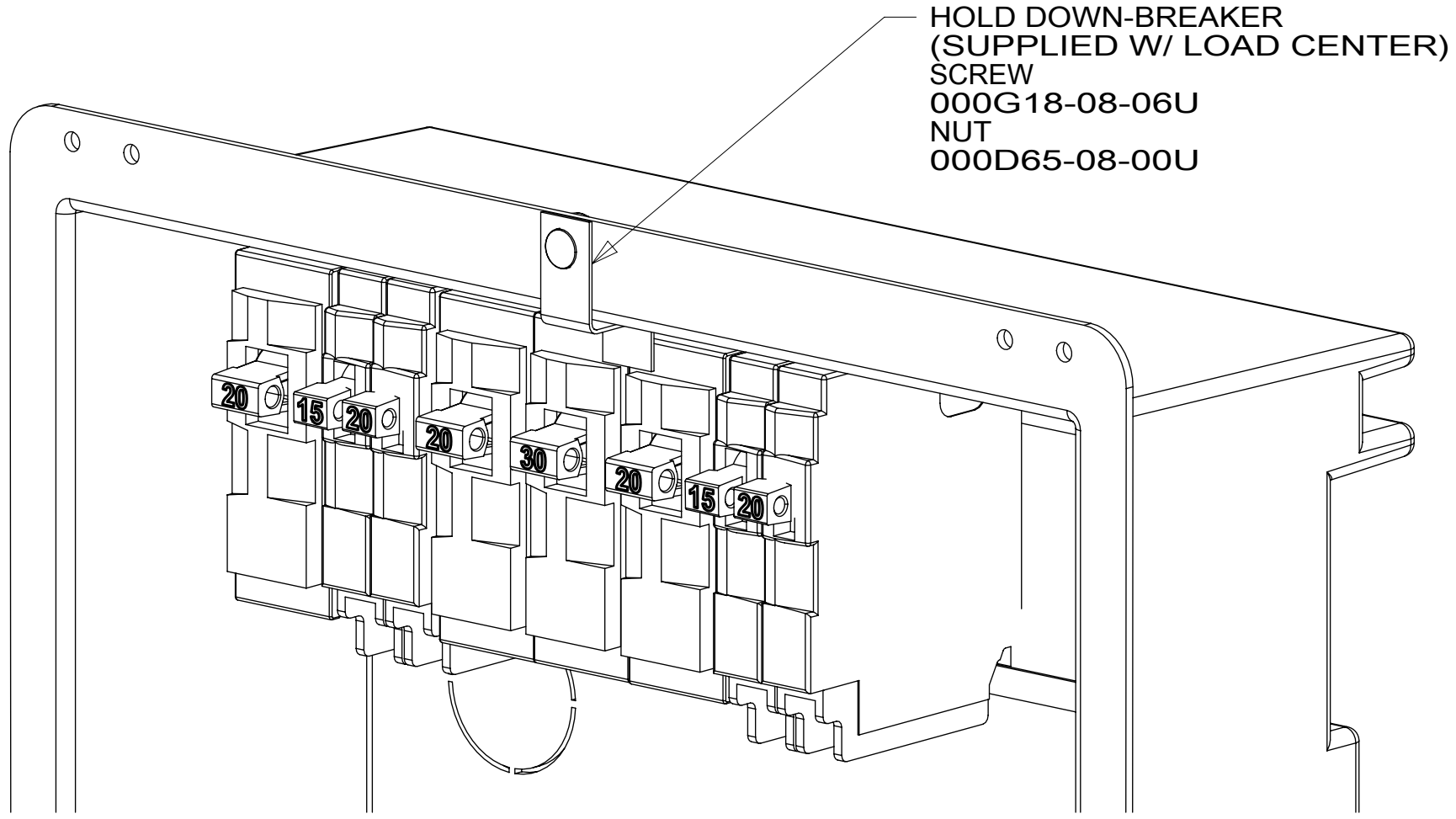

FOR ELECTRICAL TORQUE SPECIFICATIONS SEE DWG NO. 128783-01-000

FOR ELECTRICAL CALLOUTS SEE DWG NO. 121339-01-000

- 265 CODES/STANDARDS-CSA/CMVSS
- 1B1 CODES/STANDARDS USA
- 1B1 265

WINNEBAGO COPYRIGHT 2016 WINNEBAGO INDUSTRIES, INC.	
DSNR:	ALL DIMENSIONS ARE IN MILLIMETERS
DIFFR:	
UNSPECIFIED TOLERANCES:	MATERIAL:
WHOLE DIM (X) : 3	
ONE-PLACE (X.X) : 1.5	
TWO-PLACE (X.XX) : 0.50	
ANGLE : 1°	
REFER TO ES0018 FOR FASTENER TIGHTENING GUIDELINES	WEIGHT: (LBS) FIRST USED: 18 144E
LOAD CENTER ASM	
SHEET: 1 OF 1	ITEM/PART NO: 000043541 / 32085601000

NOTES:
1. ALL GROUNDS TO BE COVERED WITH TUBING 8041-02-000.

8 7 6 5 4 3 2 1