

8 7 6 5 4 3 2 1

D

D

C

C

B

B

A

A

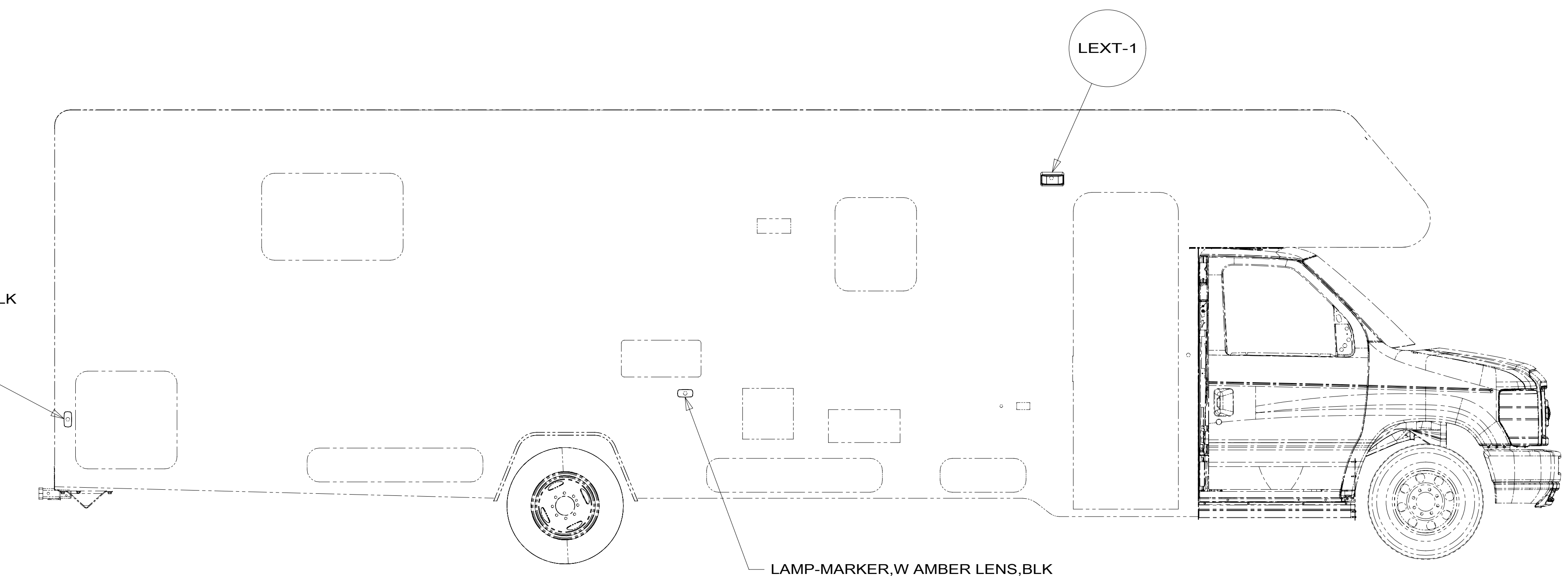

LAMP-MARKER, W RED LENS, BLK
193802-04-000
SCREW
G11-08-12U (2)

LAMP-MARKER, W AMBER LENS, BLK
193802-03-000
SCREW
G11-08-12U (2)
CONNECTOR
58028-01-000 (2)

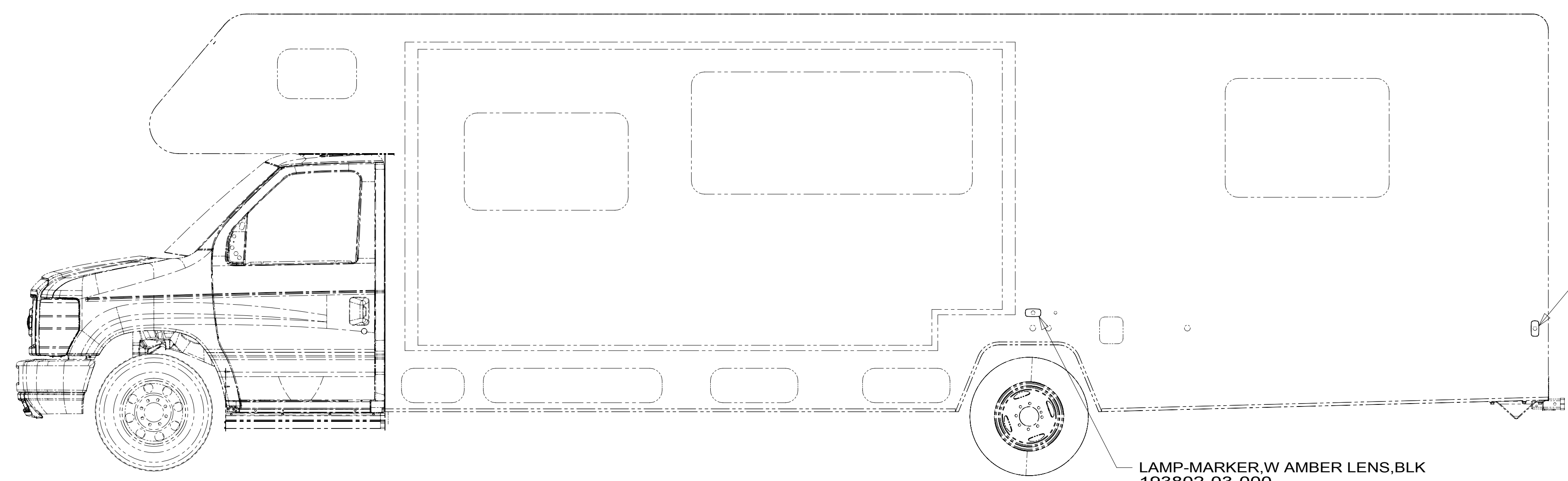

LAMP-MARKER, W AMBER LENS, BLK
193802-03-000
SCREW
G11-08-12U (2)
CONNECTOR
58028-01-000 (2)

LAMP-MARKER, W RED LENS, BLK
193802-04-000
SCREW
G11-08-12U (2)

- 265 CODES/STANDARDS-CSA/CMVSS
- 1B1 CODES/STANDARDS USA
- 1B1 265



DSNR:		ALL DIMENSIONS ARE IN MILLIMETERS	
DFFR:		MATERIAL:	
UNSPECIFIED TOLERANCES:			
WHOLE DIM (X)	: 3		
ONE-PLACE (X.X)	: 1.5		
TWO-PLACE (X.XX)	: 0.50		
ANGLE	: 1°		
REFER TO ES0018 FOR FASTENER TIGHTENING GUIDELINES		WEIGHT: (LBS)	FIRST USED:
			18 331K

FOR ELECTRICAL TORQUE SPECIFICATIONS SEE DWG NO. 128783-01-000

FOR ELECTRICAL CALLOUTS SEE DWG NO. 121339-01-000

WIRING INSTL-EXTERIOR LAMPS

SHEET: 1 OF 2 ITEM/PART NO.: 000041970 / 31996701000 REF: 1 07-Sep-2017

8 7 6 5 4 3 2 1

8 7 6 5 4 3 2 1

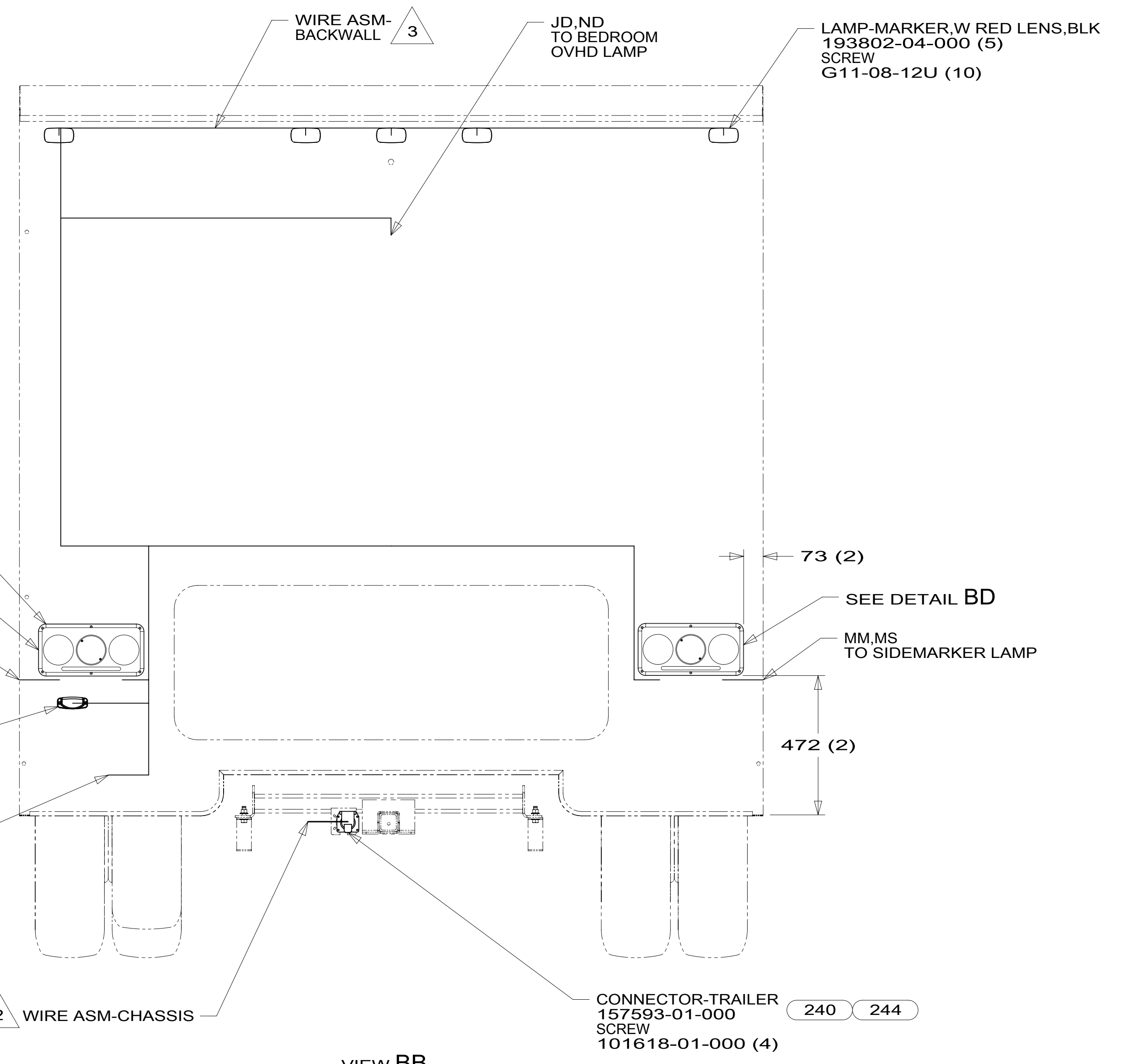
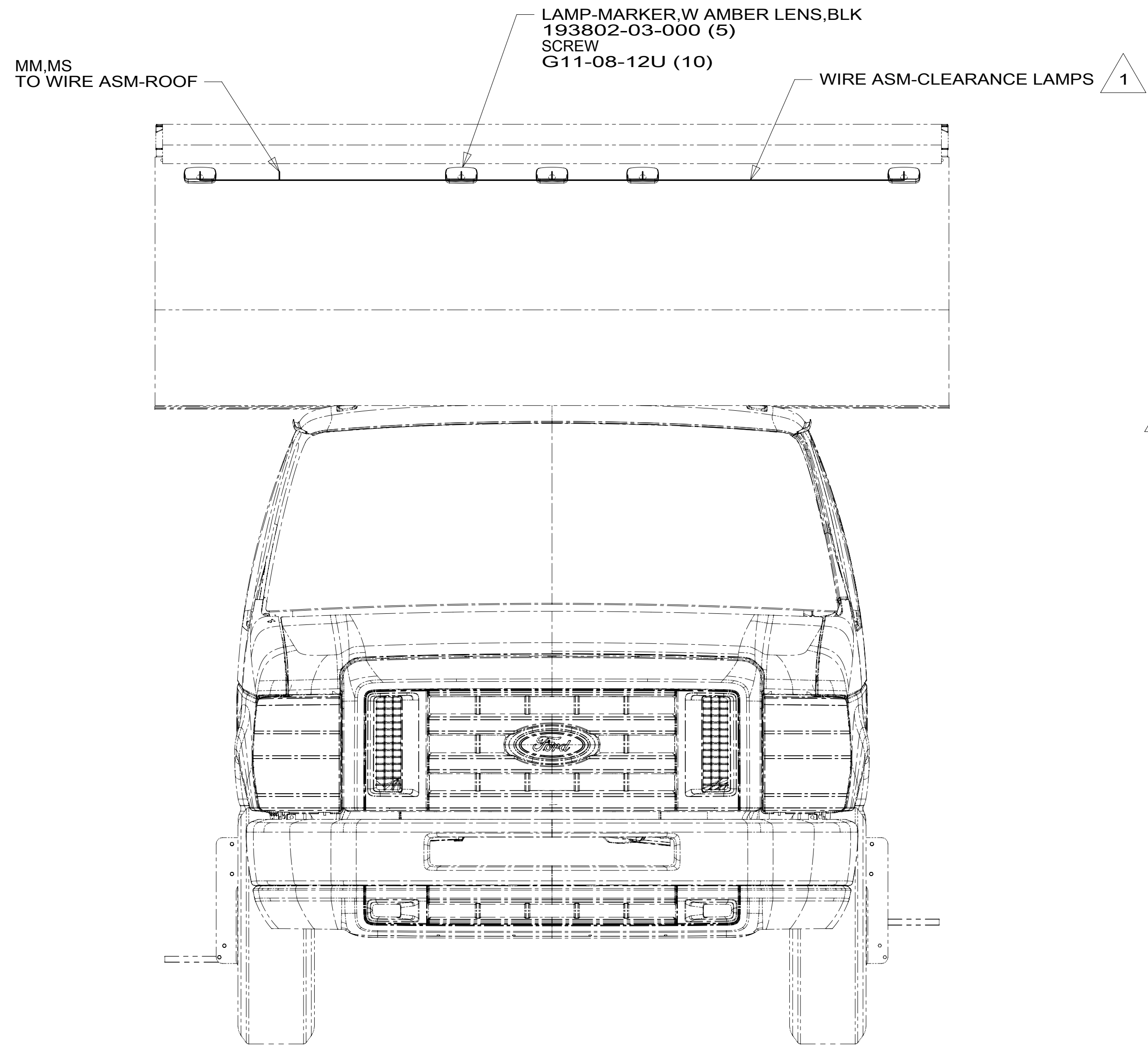

VIEW BA

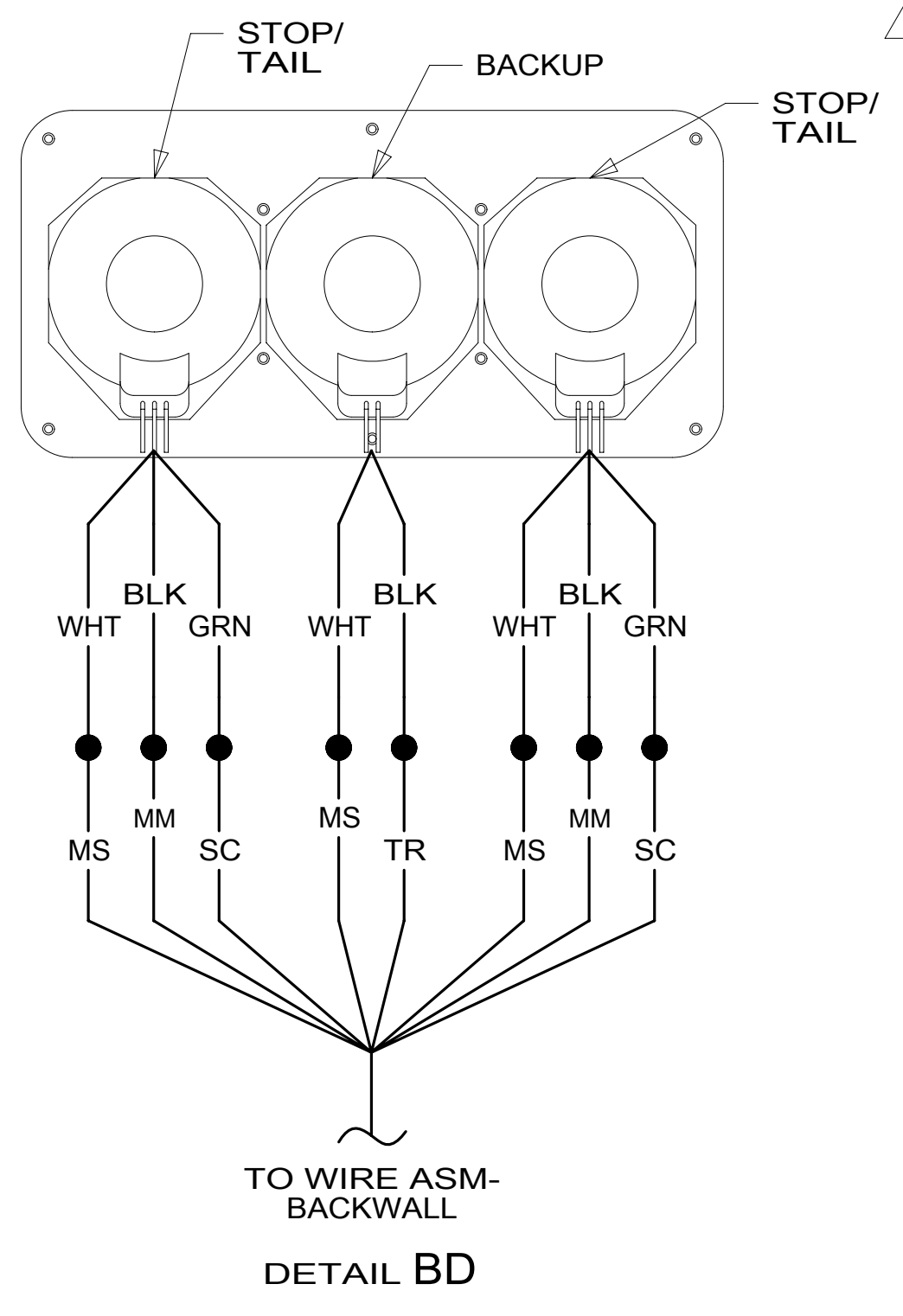
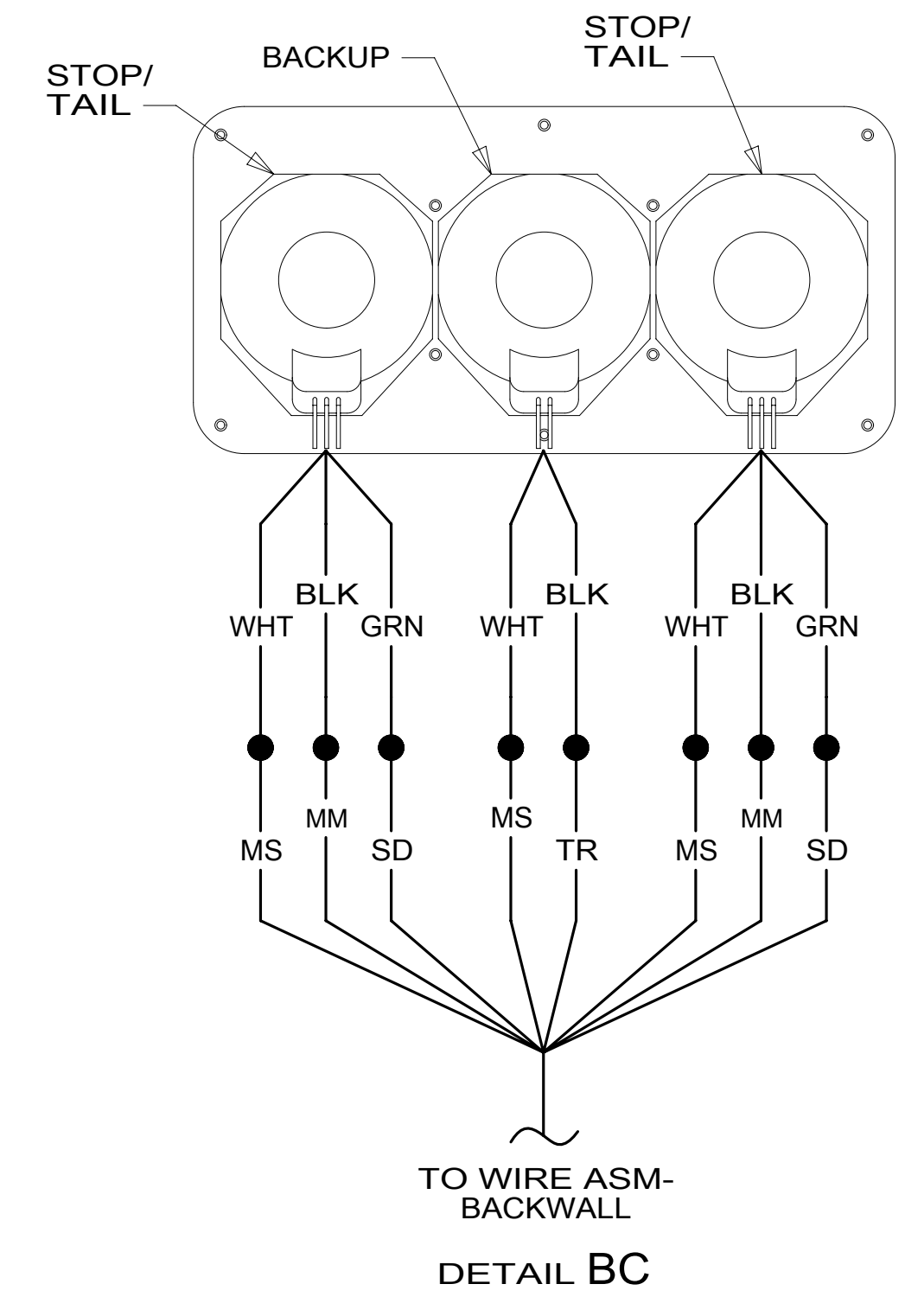

VIEW BB

- NOTES:
- 4 TAIL LAMP MUST BE INSTALLED WITH WIRES DOWN.
 - 3 LOCATED IN BACKWALL ASM.
 - 2 SECURE WIRE BELOW COACH WITH CLAMP 10495-01-000 AND SCREW G67-10-12U.
 - 1 LOCATED IN ROOF ASM-FRONT.

FOR ELECTRICAL TORQUE SPECIFICATIONS SEE DWG NO. 128783-01-000

FOR ELECTRICAL CALLOUTS SEE DWG NO. 121339-01-000

- 244 TRAILER HITCH-7500# DRAW BAR
- 240 TRAILER HITCH
- 265 CODES/STANDARDS-CSA/CMVSS
- 1B1 CODES/STANDARDS USA

DESCRIPTION: WIRING INSTL-EXTERIOR LAMPS		
SHEET: 2 OF 2	ITEM/PART NO: 000041970 / 31996701000	REV

8 7 6 5 4 3 2 1 07-Sep-2017