

- NOTES:
- 3 LOCATED IN STORAGE COMPARTMENT BELOW FLOOR.
  - 2 USED TO COVER CABLE-MONITOR WIRE.
  - 1. AT MINIMUM ALL WIRES TO BE SUPPORTED AND SECURED PER CODE REQUIREMENTS. USE CLAMP 10495 OR 10497 OR WIRE TIE 8343 OR 108046 AND SCREW G67-XX-XXX OR G56-XX-XXX AS APPROPRIATE FOR INSTALLATION.

FOR ELECTRICAL TORQUE SPECIFICATIONS SEE DWG NO. 128783-01-000

FOR ELECTRICAL CALLOUTS SEE DWG NO. 121339-01-000

265 CODES/STANDARDS-CSA/CMVSS  
 1B1 CODES/STANDARDS USA

1B1 265

**WINNEBAGO**  
 COPYRIGHT 2016 WINNEBAGO INDUSTRIES, INC.

DSNR:	ALL DIMENSIONS ARE IN MILLIMETERS	
DFFR:	MATERIAL:	
UNSPECIFIED TOLERANCES:	WEIGHT: (LBS)	FIRST USED:
WHOLE DIM (X) : 3		<b>18 331K</b>
ONE-PLACE (X.X) : 1.5		
TWO-PLACE (X.XX) : 0.50		
ANGLE : 1°		

REFER TO ES0018 FOR FASTENER TIGHTENING GUIDELINES

DESCRIPTION:  
**WIRING INSTL-BODY, 12V**

SHEET: 1 OF 4	ITEM/PART NO: 000039642 / 31912001000	REV:
---------------	---------------------------------------	------

REF: 1 05-Oct-2018

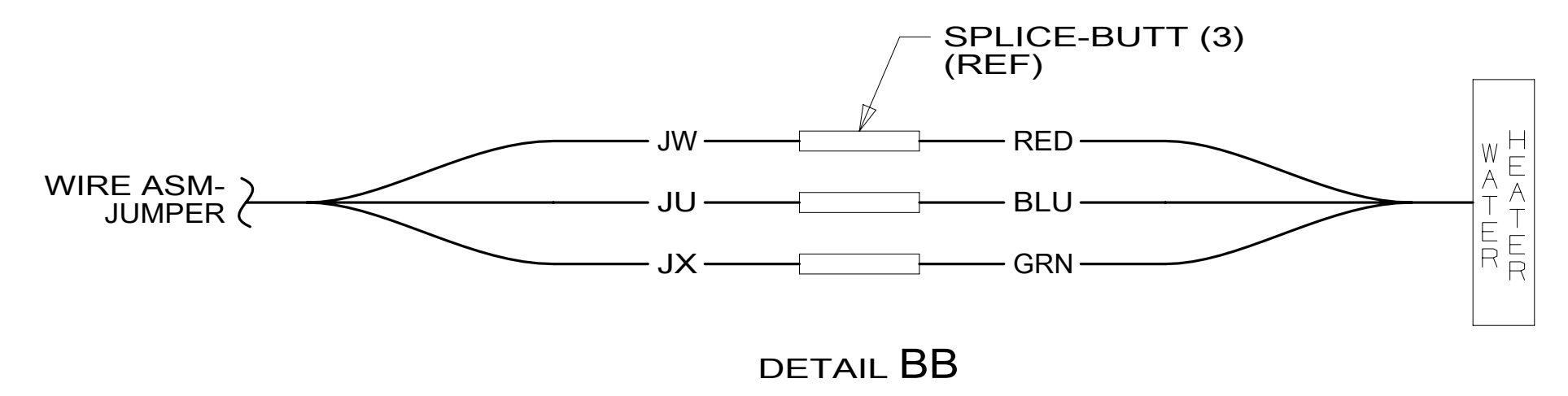
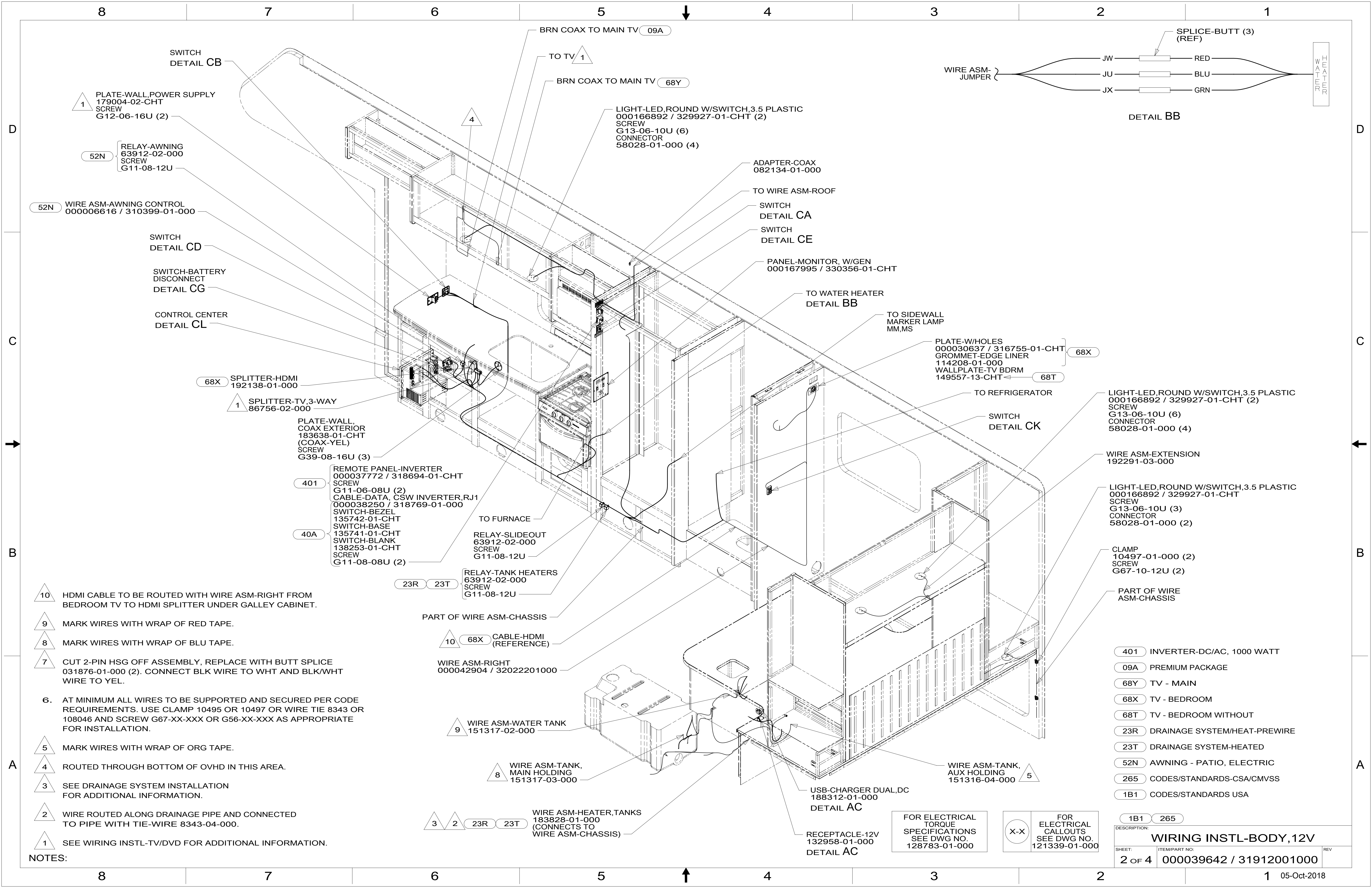

- NOTES:**
- 1 SEE WIRING INSTL-TV/DVD FOR ADDITIONAL INFORMATION.
  - 2 WIRE ROUTED ALONG DRAINAGE PIPE AND CONNECTED TO PIPE WITH TIE-WIRE 8343-04-000.
  - 3 SEE DRAINAGE SYSTEM INSTALLATION FOR ADDITIONAL INFORMATION.
  - 4 ROUTED THROUGH BOTTOM OF OVHD IN THIS AREA.
  - 5 MARK WIRES WITH WRAP OF ORG TAPE.
  - 6. AT MINIMUM ALL WIRES TO BE SUPPORTED AND SECURED PER CODE REQUIREMENTS. USE CLAMP 10495 OR 10497 OR WIRE TIE 8343 OR 108046 AND SCREW G67-XX-XXX OR G56-XX-XXX AS APPROPRIATE FOR INSTALLATION.
  - 7 CUT 2-PIN HSG OFF ASSEMBLY, REPLACE WITH BUTT SPLICE 031876-01-000 (2). CONNECT BLK WIRE TO WHT AND BLK/WHT WIRE TO YEL.
  - 8 MARK WIRES WITH WRAP OF BLU TAPE.
  - 9 MARK WIRES WITH WRAP OF RED TAPE.
  - 10 HDMI CABLE TO BE ROUTED WITH WIRE ASM-RIGHT FROM BEDROOM TV TO HDMI SPLITTER UNDER GALLEY CABINET.

- 401 INVERTER-DC/AC, 1000 WATT
- 09A PREMIUM PACKAGE
- 68Y TV - MAIN
- 68X TV - BEDROOM
- 68T TV - BEDROOM WITHOUT
- 23R DRAINAGE SYSTEM/HEAT-PREWIRE
- 23T DRAINAGE SYSTEM-HEATED
- 52N AWNING - PATIO, ELECTRIC
- 265 CODES/STANDARDS-CSA/CMVSS
- 1B1 CODES/STANDARDS USA

FOR ELECTRICAL TORQUE SPECIFICATIONS SEE DWG NO. 128783-01-000

FOR ELECTRICAL CALLOUTS SEE DWG NO. 121339-01-000

DESCRIPTION:		1B1 265	
<b>WIRING INSTL-BODY, 12V</b>			
SHEET:	ITEM/PART NO.:	REV:	
2 OF 4	000039642 / 31912001000		

RECEPTACLE-12V 132958-01-000  
DETAIL AC

WIRE ASM-HEATER,TANKS 183828-01-000 (CONNECTS TO WIRE ASM-CHASSIS)

WIRE ASM-WATER TANK 151317-02-000

WIRE ASM-RIGHT 000042904 / 32022201000

RELAY-TANK HEATERS 63912-02-000 SCREW G11-08-12U

40A SWITCH-BLANK 138253-01-CHT SCREW G11-08-08U (2)

401 REMOTE PANEL-INVERTER 000037772 / 318694-01-CHT SCREW G11-06-08U (2)

CABLE-DATA, CSW INVERTER,RJ1 000038250 / 318769-01-000

SWITCH-BEZEL 135742-01-CHT

SWITCH-BASE 135741-01-CHT

PLATE-WALL, COAX EXTERIOR 183638-01-CHT (COAX-YEL) SCREW G39-08-16U (3)

68X PLATE-W/HOLES 000030637 / 316755-01-CHT

GROMMET-EDGE LINER 114208-01-000

WALLPLATE-TV BDRM 149557-13-CHT

68T

PANEL-MONITOR, W/GEN 000167995 / 330356-01-CHT

ADAPTER-COAX 082134-01-000

LIGHT-LED,ROUND W/SWITCH,3.5 PLASTIC 000166892 / 329927-01-CHT (2)

SCREW G13-06-10U (6)

CONNECTOR 58028-01-000 (4)

BRN COAX TO MAIN TV 09A

TO TV 1

BRN COAX TO MAIN TV 68Y

SWITCH DETAIL CB

1 PLATE-WALL,POWER SUPPLY 179004-02-CHT SCREW G12-06-16U (2)

52N RELAY-AWNING 63912-02-000 SCREW G11-08-12U

52N WIRE ASM-AWNING CONTROL 000006616 / 310399-01-000

SWITCH DETAIL CD

SWITCH-BATTERY DISCONNECT DETAIL CG

CONTROL CENTER DETAIL CL

68X SPLITTER-HDMI 192138-01-000

1 SPLITTER-TV,3-WAY 86756-02-000

TO WATER HEATER DETAIL BB

TO SIDEWALL MARKER LAMP MM,MS

TO REFRIGERATOR

SWITCH DETAIL CK

LIGHT-LED,ROUND W/SWITCH,3.5 PLASTIC 000166892 / 329927-01-CHT (2)

SCREW G13-06-10U (6)

CONNECTOR 58028-01-000 (4)

WIRE ASM-EXTENSION 192291-03-000

LIGHT-LED,ROUND W/SWITCH,3.5 PLASTIC 000166892 / 329927-01-CHT

SCREW G13-06-10U (3)

CONNECTOR 58028-01-000 (2)

CLAMP 10497-01-000 (2)

SCREW G67-10-12U (2)

PART OF WIRE ASM-CHASSIS

PART OF WIRE ASM-CHASSIS

10 68X CABLE-HDMI (REFERENCE)

WIRE ASM-TANK, MAIN HOLDING 151317-03-000

RELAY-SLIDEOUT 63912-02-000 SCREW G11-08-12U

TO FURNACE

23R 23T

8 WIRE ASM-TANK, MAIN HOLDING 151317-03-000

5 WIRE ASM-TANK, AUX HOLDING 151316-04-000

3 2 23R 23T

USB-CHARGER DUAL,DC 188312-01-000

DETAIL AC

RECEPTACLE-12V 132958-01-000

DETAIL AC

FOR ELECTRICAL TORQUE SPECIFICATIONS SEE DWG NO. 128783-01-000

FOR ELECTRICAL CALLOUTS SEE DWG NO. 121339-01-000

**WARNING**  
 CRUSH HAZARD. Keep people and objects clear of the inside and outside of the slideout room when operating. Failure to comply could result in death or serious injury.

LABEL-WARNING, SLIDEOUT  
 116549-02-000

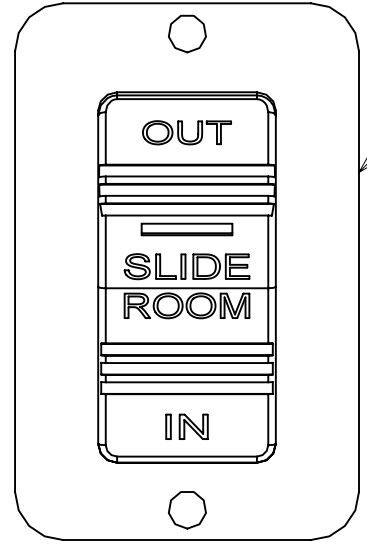
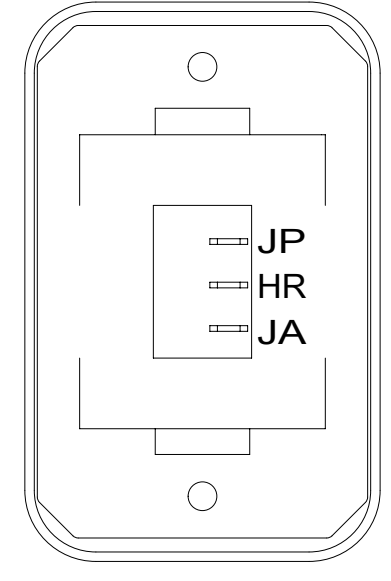

PLATE-SWITCH  
 144363-02-CHT  
 SWITCH  
 108357-18-000  
 ACTUATOR  
 108356-31-CHT  
 SCREW  
 G11-08-08U (2)

DETAIL CA



**HOLDING TANK HEATER**  
 TURN OFF When Not In Use  
 SEE OPERATORS MANUAL

DETAIL CE

SWITCH-ROCKER  
 135740-06-CHT  
 SWITCH-BASE  
 135741-01-CHT  
 SWITCH-BEZEL  
 135742-01-CHT  
 LABEL-SWITCH  
 134563-01-CHT  
 SCREW  
 G11-08-08U (2)  
 SWITCH-BEZEL  
 135741-02-CHT  
 SWITCH-BASE  
 135741-01-CHT  
 SWITCH-BLANK  
 138253-01-CHT  
 SCREW  
 G11-08-08U (2)

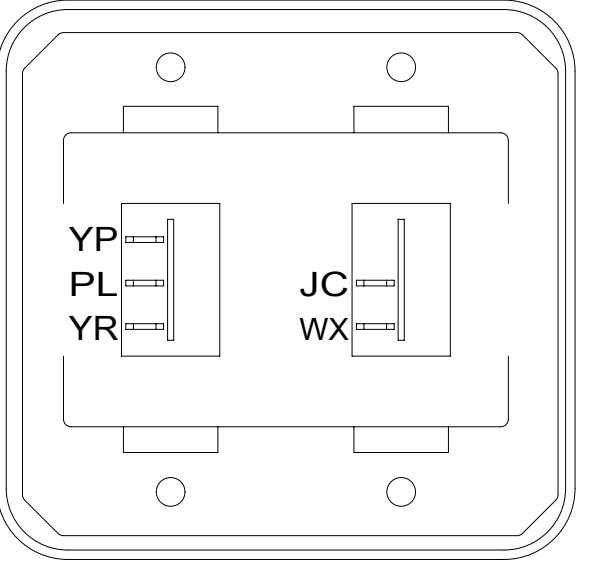

SWITCH-ROCKER  
 135740-01-CHT  
 135740-02-CHT  
 SWITCH-BASE  
 135741-02-CHT  
 SWITCH-BEZEL  
 135742-02-CHT  
 SCREW  
 G11-08-08U (4)

DETAIL CJ

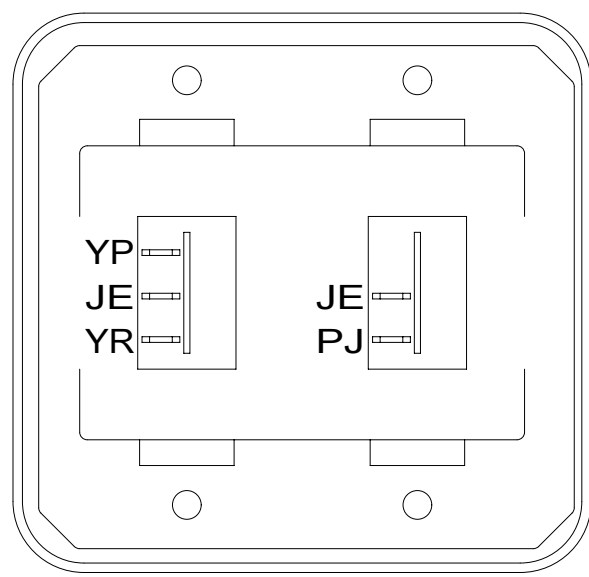

SWITCH-ROCKER  
 135740-01-CHT  
 135740-02-CHT  
 SWITCH-BASE  
 135741-02-CHT  
 SWITCH-BEZEL  
 135742-02-CHT  
 SCREW  
 G11-08-08U (4)

DETAIL CB

4-PIN HSG  
 CIRCUITS:  
 ABY,ABZ  
 DR,DU

2-PIN HSG  
 CIRCUIT:  
 DDJ

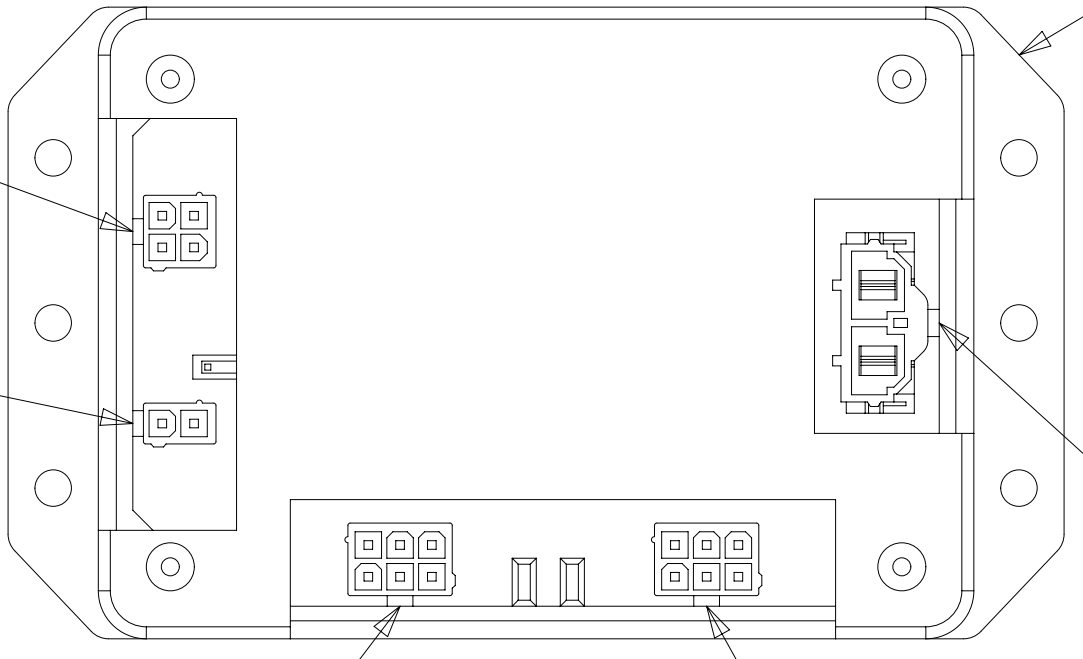

CONTROL-SLIDEOUT  
 189400-01-000  
 SCREW  
 G39-10-12U (4)

2-PIN HSG  
 CIRCUITS:  
 LLK,LLL

6-PIN HSG FROM  
 FRONT LEFT ROOM  
 LEFT MOTOR (GRN)

6-PIN HSG FROM  
 FRONT LEFT ROOM  
 RIGHT MOTOR (YEL)

DETAIL CF 1

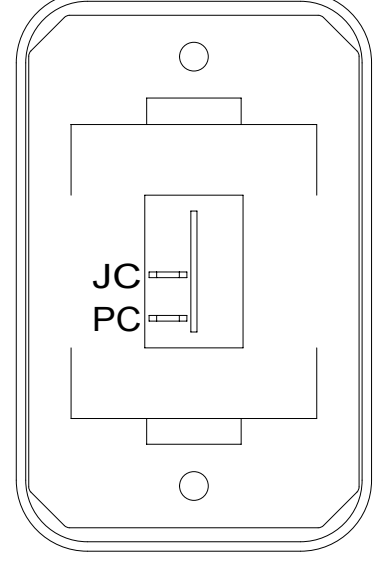

SWITCH-ROCKER  
 135740-01-CHT  
 SWITCH-BASE  
 135741-01-CHT  
 SWITCH-BEZEL  
 135742-01-CHT  
 SCREW  
 G11-08-08U (2)

DETAIL CK

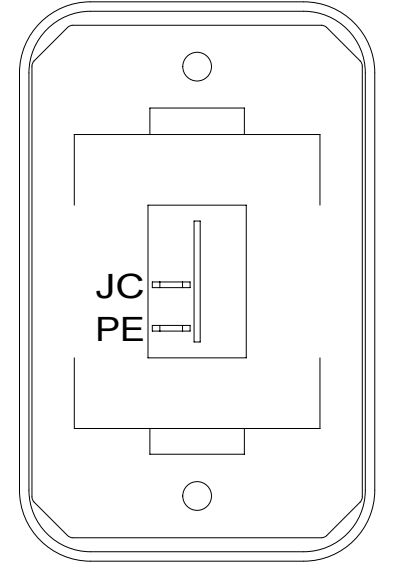

SWITCH-ROCKER  
 135740-01-CHT  
 SWITCH-BASE  
 135741-01-CHT  
 SWITCH-BEZEL  
 135742-01-CHT  
 SCREW  
 G11-08-08U (2)

DETAIL CC

SWITCH-ROCKER  
 108357-06-000  
 ACTUATOR-SWITCH  
 108356-12-CHT  
 SWITCH-BLANK  
 096241-03-000

SWITCH-ROCKER  
 108357-14-000  
 ACTUATOR-SWITCH  
 108356-28-CHT  
 SWITCH-BLANK  
 096241-03-000

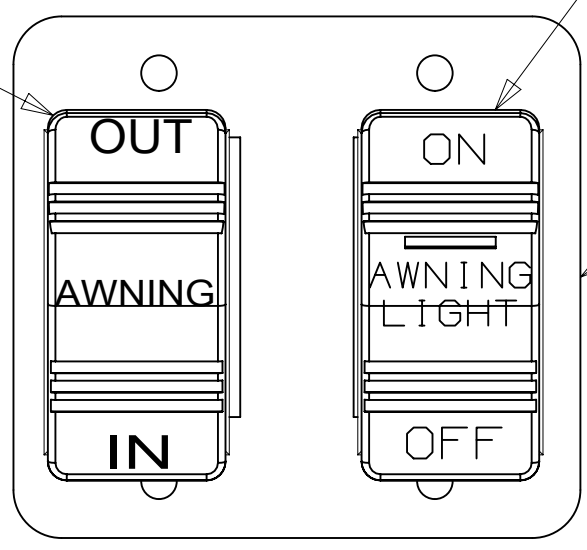

PLATE-SWITCH  
 158431-19-CHT  
 SCREW  
 G11-06-10U (4)

DETAIL CD

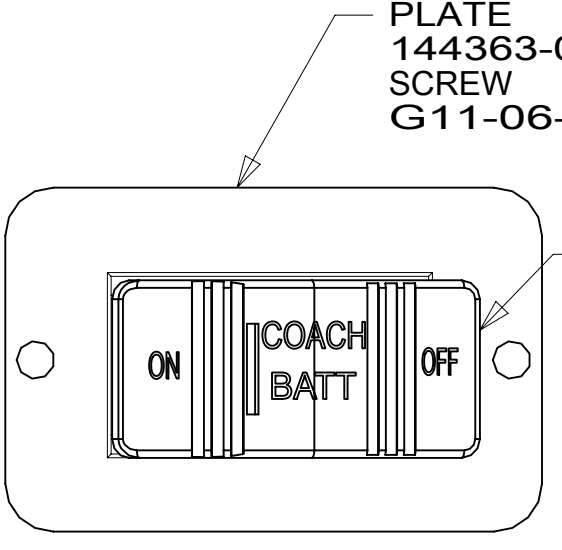

PLATE  
 144363-02-CHT  
 SCREW  
 G11-06-10U (2)

SWITCH-BATTERY  
 108357-18-000  
 ACTUATOR  
 108356-19-CHT  
 CIRCUITS LH,LJ,  
 LG,JP,JA  
 WIRE ASM-THERMISTOR  
 186796-01-000

DETAIL CG

FUSE-5 AMP  
 062901-02-000 (2)

FUSE-30 AMP  
 062901-08-000

J 6 BLK  
 (BATTERY COMPT)

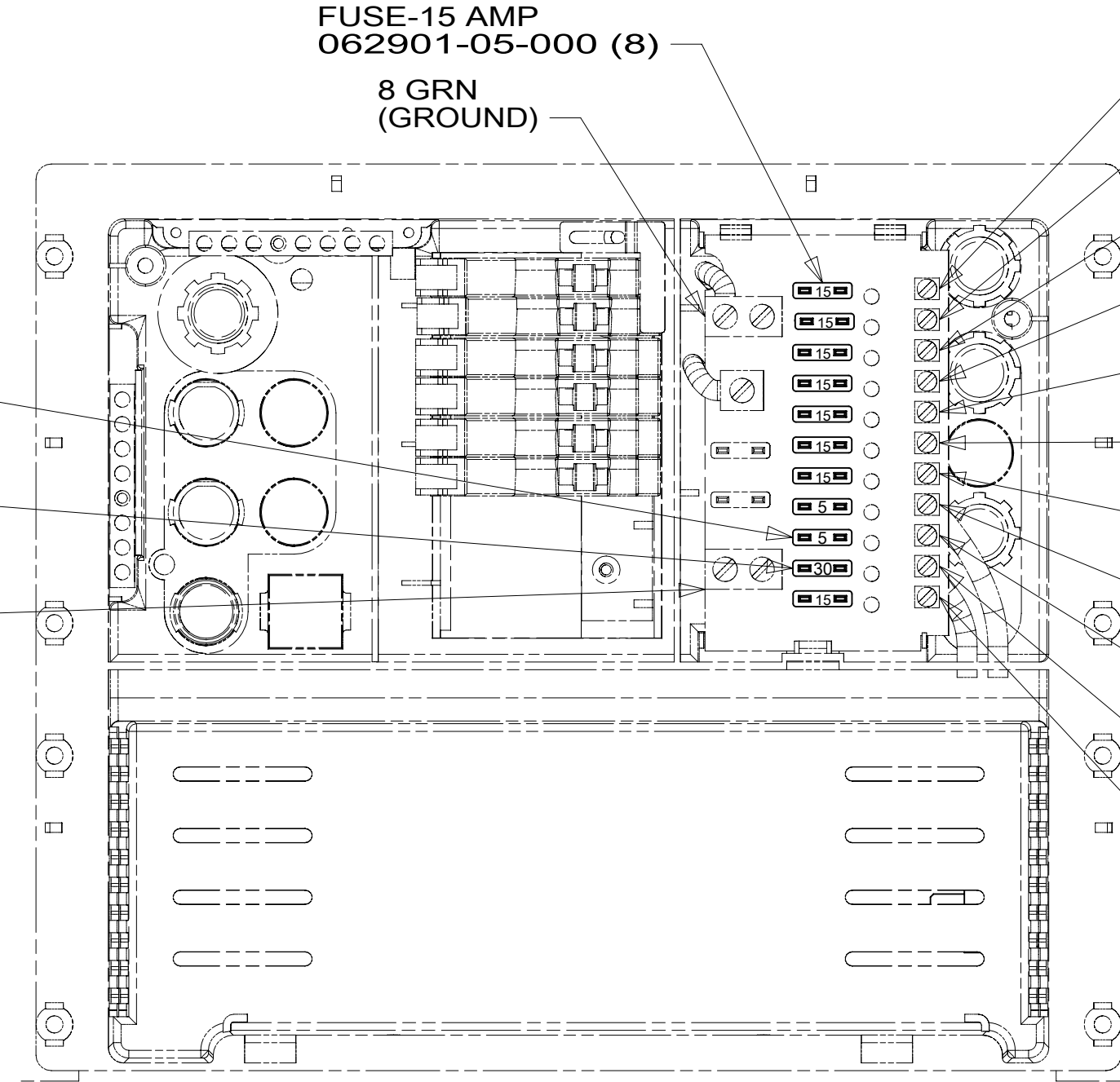

FUSE-15 AMP  
 062901-05-000 (8)

8 GRN  
 (GROUND)

JC 14 Y  
 (LAMPS)

JD 14 Y  
 (LAMPS)

JE 14 Y  
 (LAMPS)

NM 12 Y  
 (TANK HEATERS)

JA 14 Y  
 (MONITOR PANEL & PUMP)

JB 14 Y  
 (FURNACE)

FFD 12 Y  
 (AWNING)

WB 16 Y  
 (LP DETECTOR)

ET 16 Y  
 (REFRIGERATOR)

LLK 10 Y  
 (SLIDEOUT)

JF 14 Y  
 (TV/RADIO)

DETAIL CL

- 52F AWNING-PATIO
- 52N AWNING - PATIO, ELECTRIC
- 23R DRAINAGE SYSTEM/HEAT-PREWIRE
- 23T DRAINAGE SYSTEM-HEATED
- 1JD DRAINAGE SYSTEM-HEATED-W/O
- 265 CODES/STANDARDS-CSA/CMVSS
- 1B1 CODES/STANDARDS USA

1 WIRING IS PART OF WIRE ASM-CHASSIS.

FOR ELECTRICAL  
 TORQUE  
 SPECIFICATIONS  
 SEE DWG NO.  
 128783-01-000

FOR ELECTRICAL  
 CALLOUTS  
 SEE DWG NO.  
 121339-01-000

DESCRIPTION:  
**WIRING INSTL-BODY, 12V**

SHEET: 3 OF 4    ITEM/PART NO: 000039642 / 31912001000    REV

8 7 6 5 4 3 2 1

LIGHT-LED,ROUND 4.5 PLASTIC  
000166889 / 329926-01-CHT (10)  
SCREW  
G13-06-16U (30)  
CONNECTOR  
58028-01-000 (20)

LIGHT-LED,ROUND W/SWITCH,3.5 PLASTIC  
000166892 / 329927-01-CHT  
SCREW  
G13-06-16U (3)  
CONNECTOR  
58028-01-000 (2)

ANTENNA-TV, OMNIDIRECTIONAL  
000171487 / 331386-01-CHT  
SCREW  
G67-10-16U (4)

1J8

1

- 1J8 TV ANTENNA-OMNI DIRECTIONAL
- 265 CODES/STANDARDS-CSA/CMVSS
- 1B1 CODES/STANDARDS USA

1 SEE ANTENNA INSTALLATION MANUAL FOR  
CORRECT INSTALLATION PROCEDURE.

FOR ELECTRICAL  
TORQUE  
SPECIFICATIONS  
SEE DWG NO.  
128783-01-000

FOR  
ELECTRICAL  
CALLOUTS  
SEE DWG NO.  
121339-01-000

DESCRIPTION:	1B1 265	
<b>WIRING INSTL-BODY, 12V</b>		
SHEET:	ITEM/PART NO:	REV
4 OF 4	000039642 / 31912001000	