

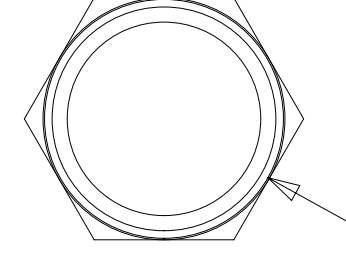



**STABILIZER DOWN**

LABEL-STABILIZER DOWN  
000007625 / 310619-01-CHT



LIGHT ASM-INDICATOR, RED  
190682-01-000  
DETAIL CC



DETAIL CA 64A

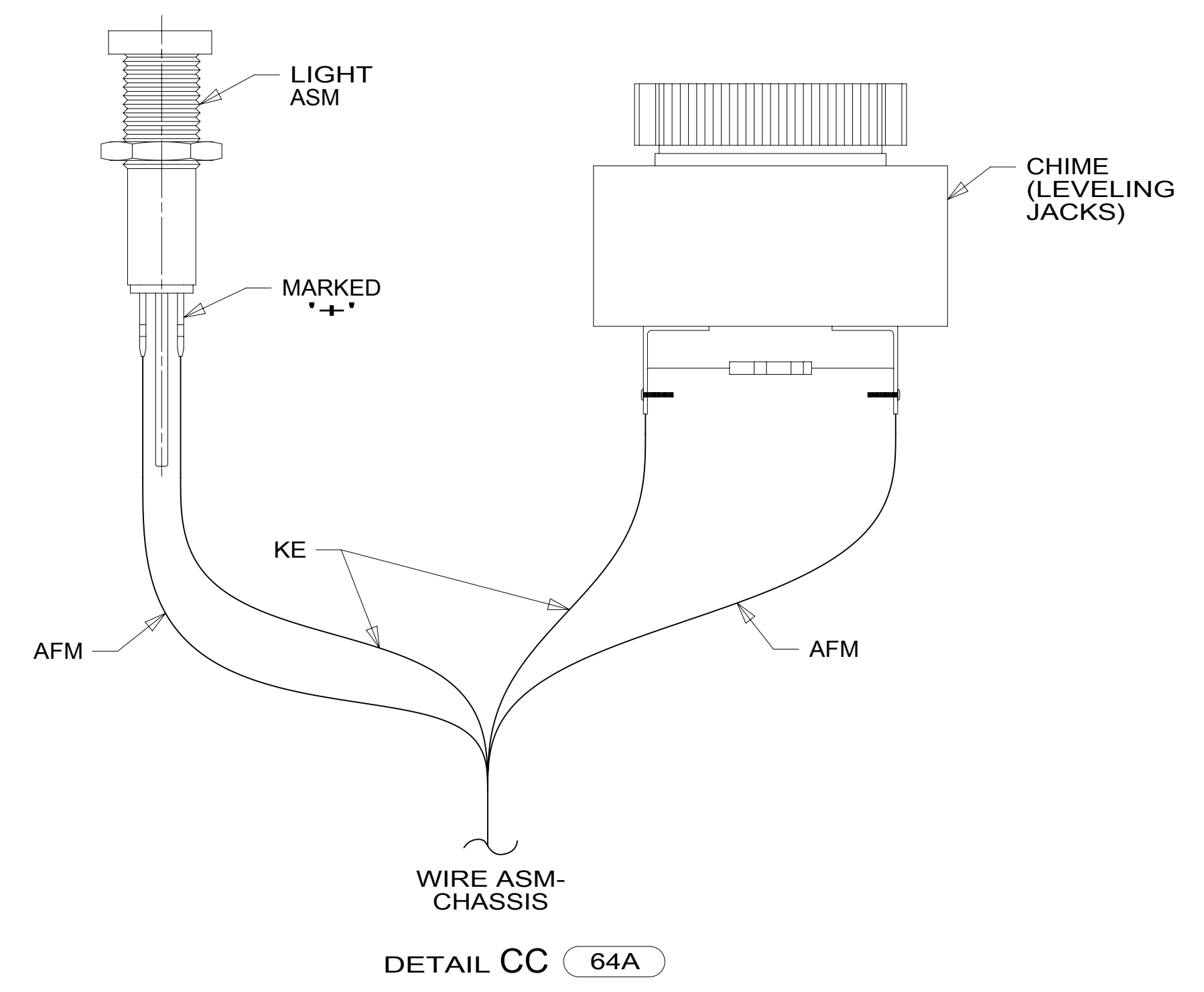

WIRE ASM-CHASSIS  
DETAIL CC 64A

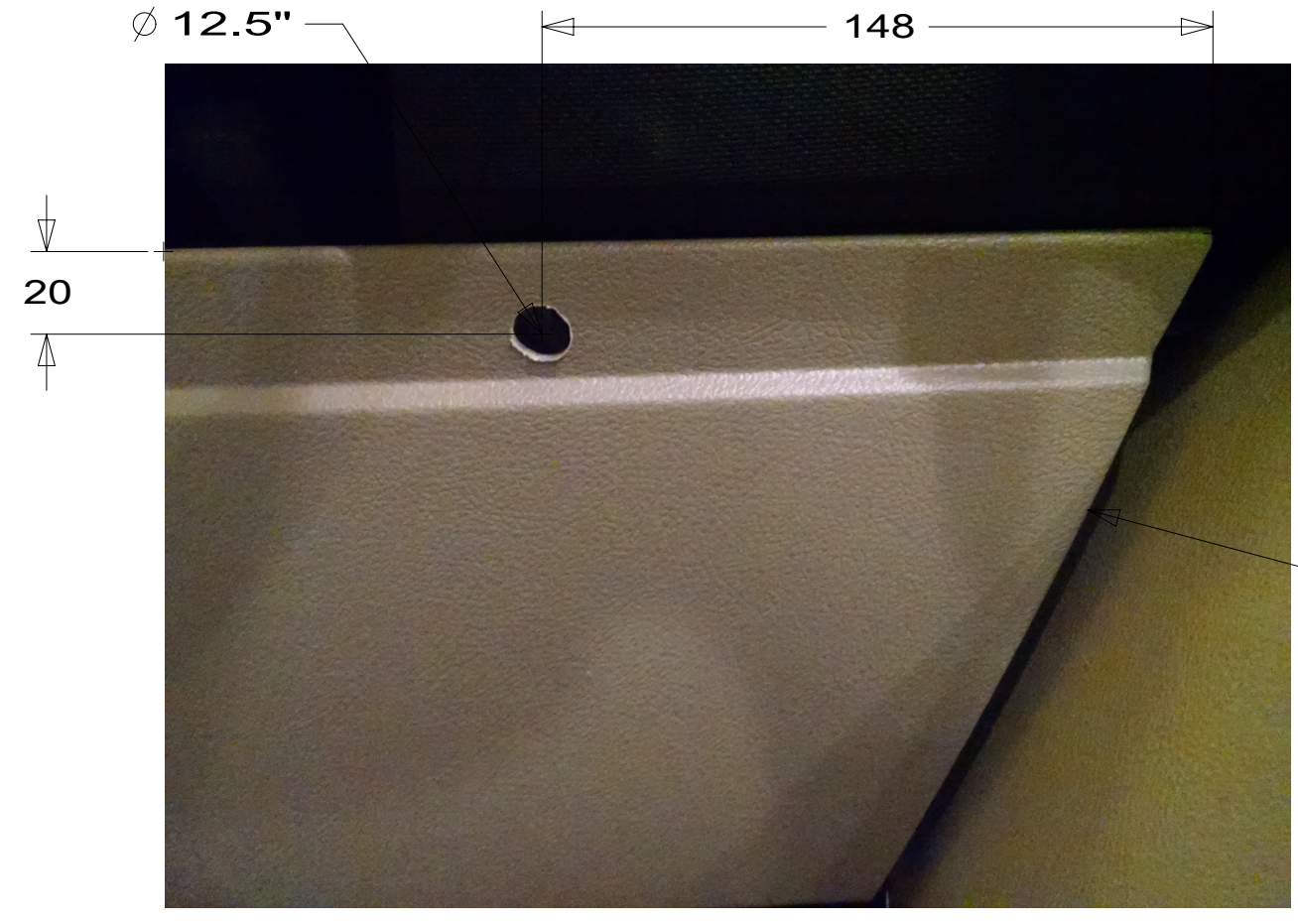

RIGHT SIDE OF STEERING COLUMN

DETAIL CB 64A

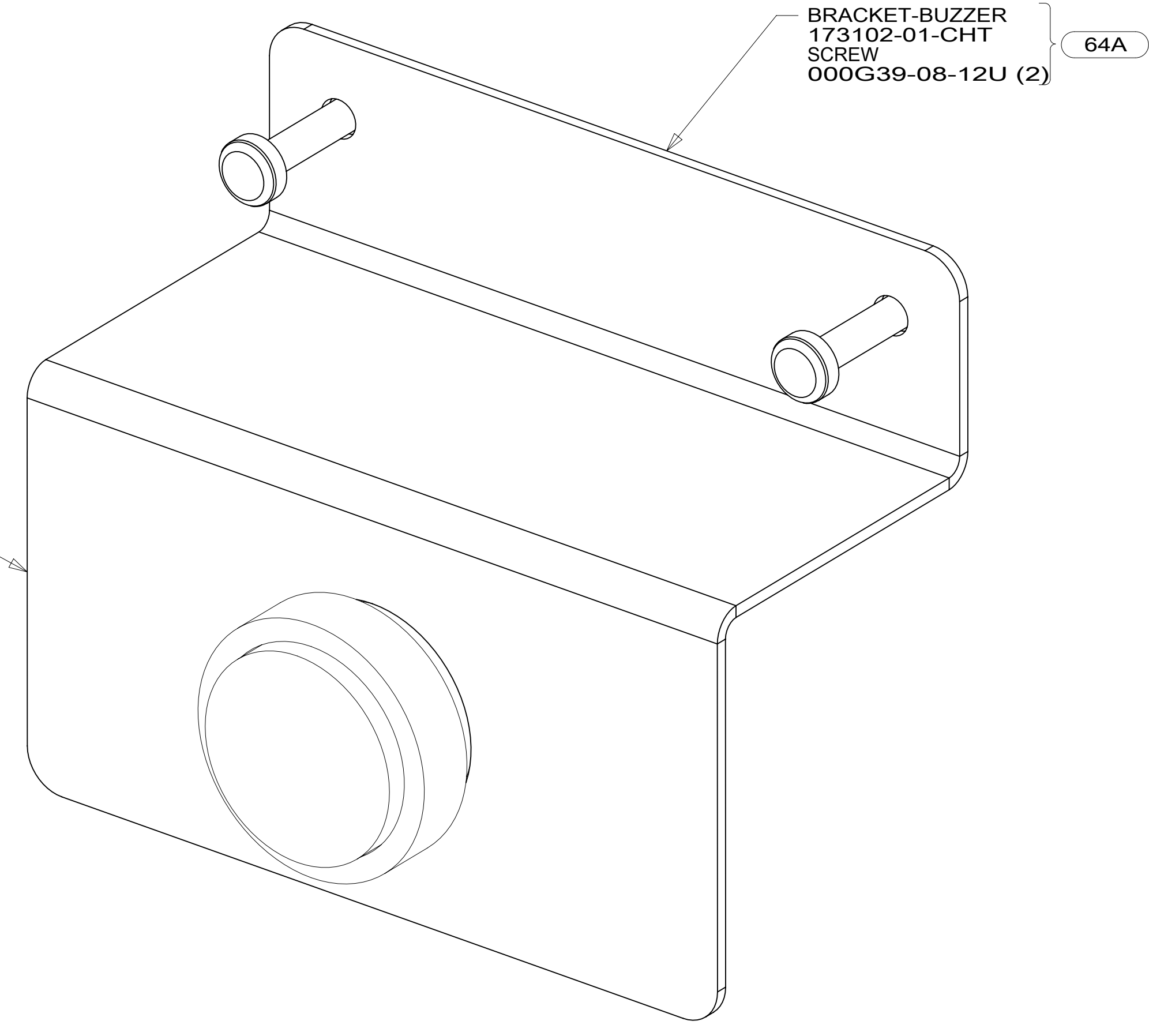

64A ALARM-STABILIZERS  
160876-01-000  
DETAIL CC

BRACKET-BUZZER  
173102-01-CHT  
SCREW  
000G39-08-12U (2)  
64A

DETAIL CD

NOTES:  
1 FOR HOLE SIZE AND LOCATION SEE DETAIL CB.

FOR ELECTRICAL TORQUE SPECIFICATIONS SEE DWG NO. 128783-01-000

FOR ELECTRICAL CALLOUTS SEE DWG NO. 121339-01-000

- 64A JACKS-STABILIZING, ELECTRIC
- 265 CODES/STANDARDS-CSA/CMVSS
- 1B1 CODES/STANDARDS USA

DESCRIPTION: <b>WIRING INSTL-CHASSIS</b>	
SHEET: 3 OF 3	ITEM/PART NO: 000038567 / 31892001000
REV	