

DETAIL AA

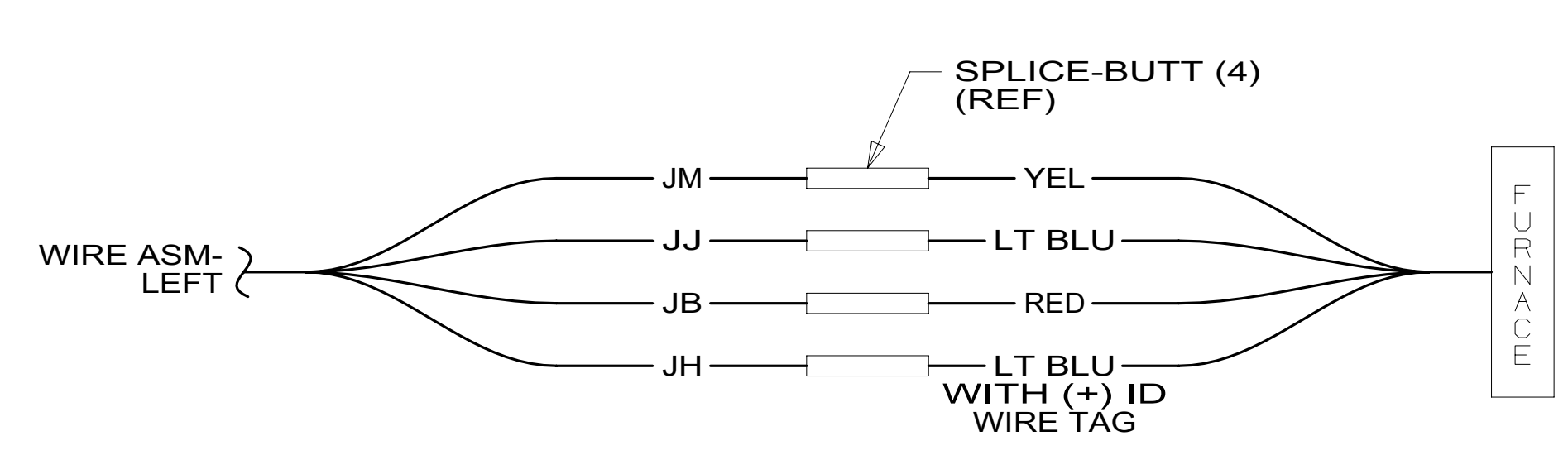

DETAIL AB

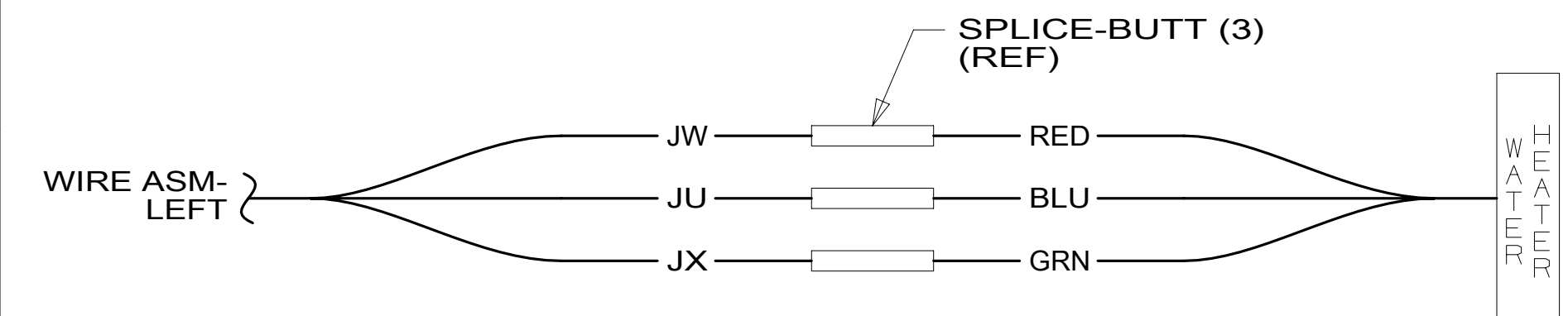

DETAIL AC

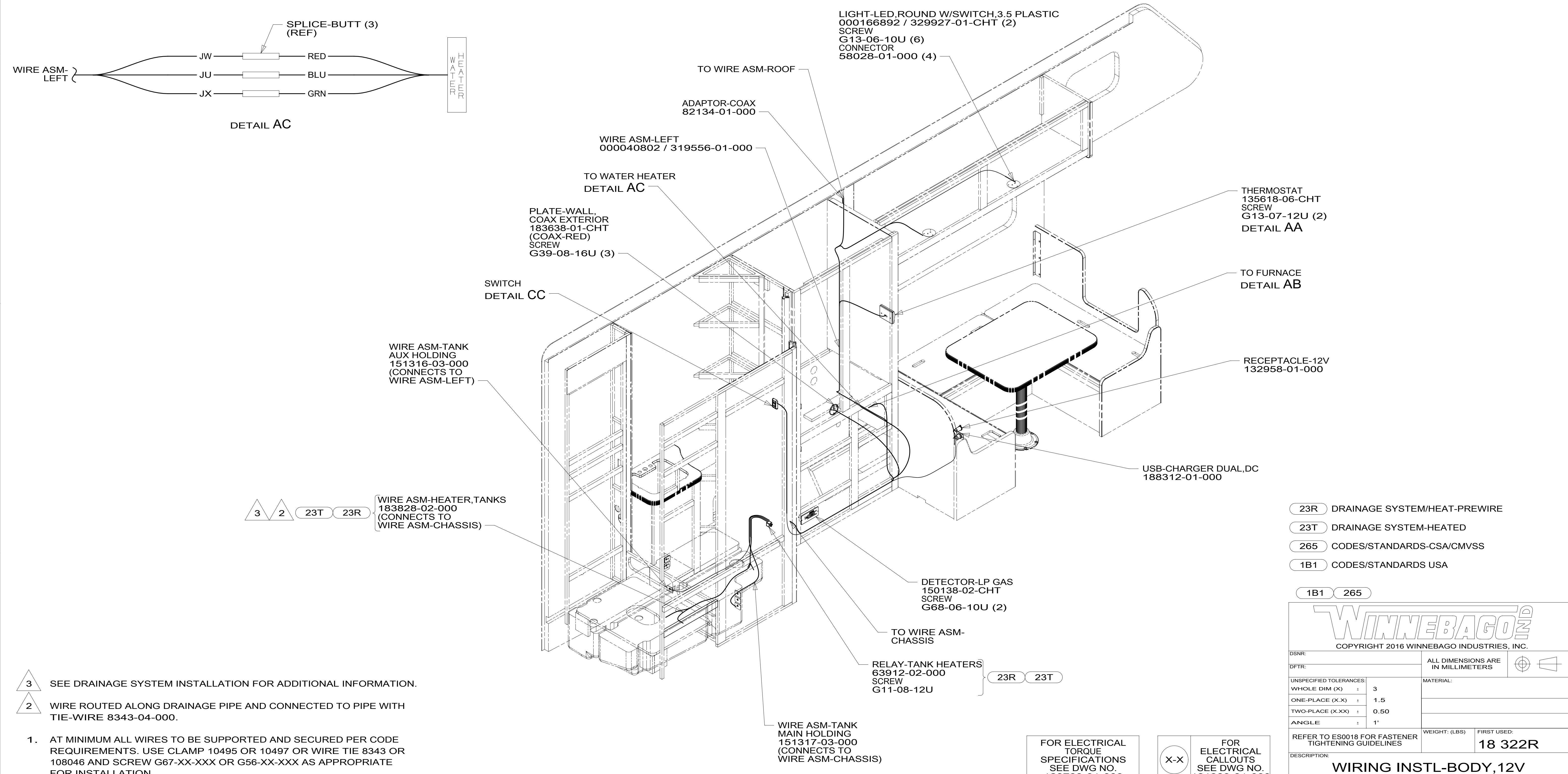

- NOTES:
- 3 SEE DRAINAGE SYSTEM INSTALLATION FOR ADDITIONAL INFORMATION.
  - 2 WIRE ROUTED ALONG DRAINAGE PIPE AND CONNECTED TO PIPE WITH TIE-WIRE 8343-04-000.
  - 1. AT MINIMUM ALL WIRES TO BE SUPPORTED AND SECURED PER CODE REQUIREMENTS. USE CLAMP 10495 OR 10497 OR WIRE TIE 8343 OR 108046 AND SCREW G67-XX-XXX OR G56-XX-XXX AS APPROPRIATE FOR INSTALLATION.

- 23R DRAINAGE SYSTEM/HEAT-PREWIRE
- 23T DRAINAGE SYSTEM-HEATED
- 265 CODES/STANDARDS-CSA/CMVSS
- 1B1 CODES/STANDARDS USA

**WINNEBAGO**  
COPYRIGHT 2016 WINNEBAGO INDUSTRIES, INC.

DSNR:	ALL DIMENSIONS ARE IN MILLIMETERS	
DFFR:	MATERIAL:	
UNSPECIFIED TOLERANCES:		
WHOLE DIM (X) :	3	
ONE-PLACE (X.X) :	1.5	
TWO-PLACE (X.XX) :	0.50	
ANGLE :	1°	
REFER TO ES0018 FOR FASTENER TIGHTENING GUIDELINES	WEIGHT: (LBS)	FIRST USED:
		<b>18 322R</b>
<b>DESCRIPTION:</b>		
<b>WIRING INSTL-BODY, 12V</b>		
SHEET:	ITEM/PART NO.:	REV:
<b>1 OF 4</b>	<b>000038564 / 31941501000</b>	
REF:		

FOR ELECTRICAL TORQUE SPECIFICATIONS SEE DWG NO. 128783-01-000

FOR ELECTRICAL CALLOUTS SEE DWG NO. 121339-01-000



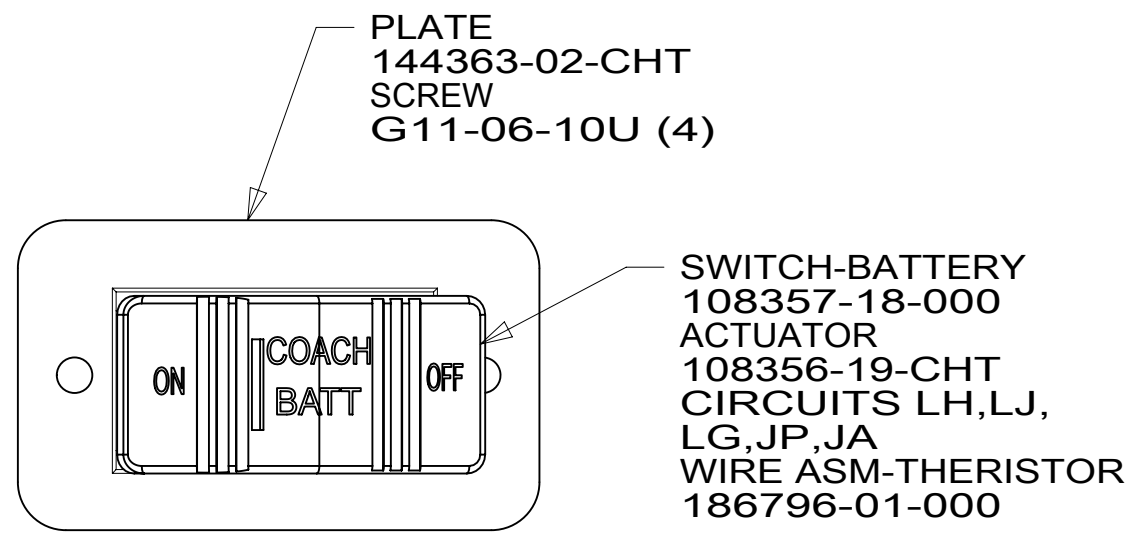

DETAIL CA

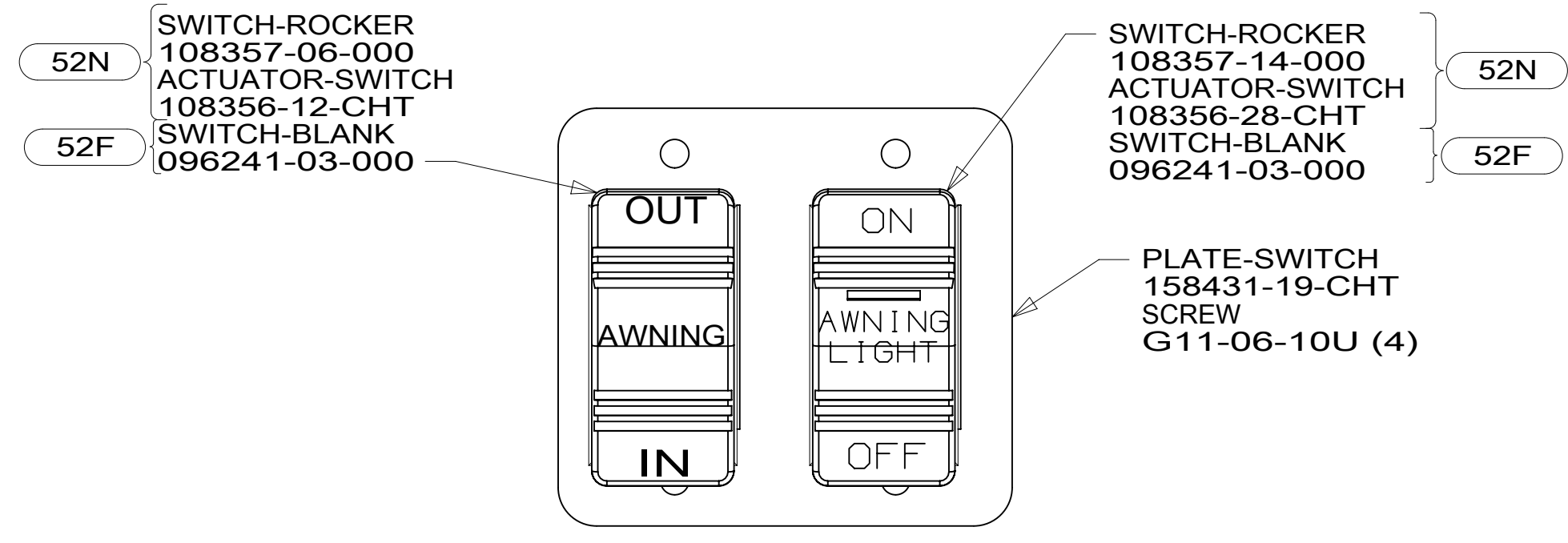

DETAIL CD

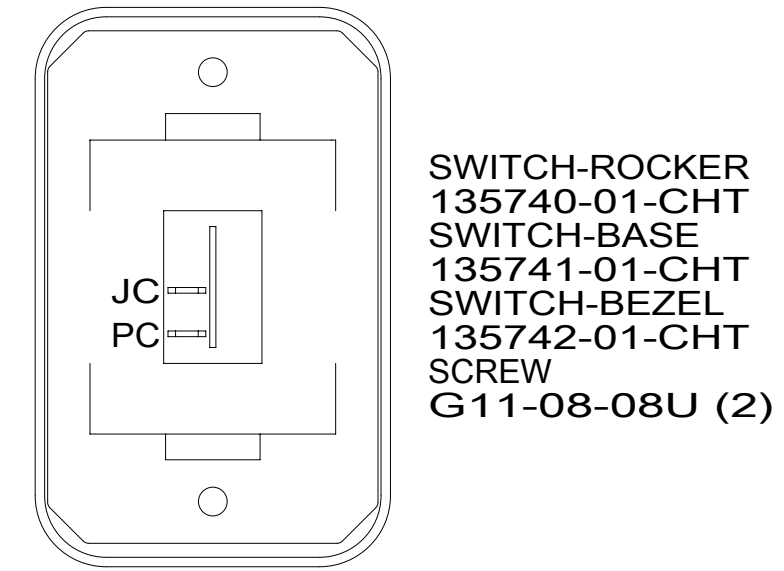

DETAIL CH

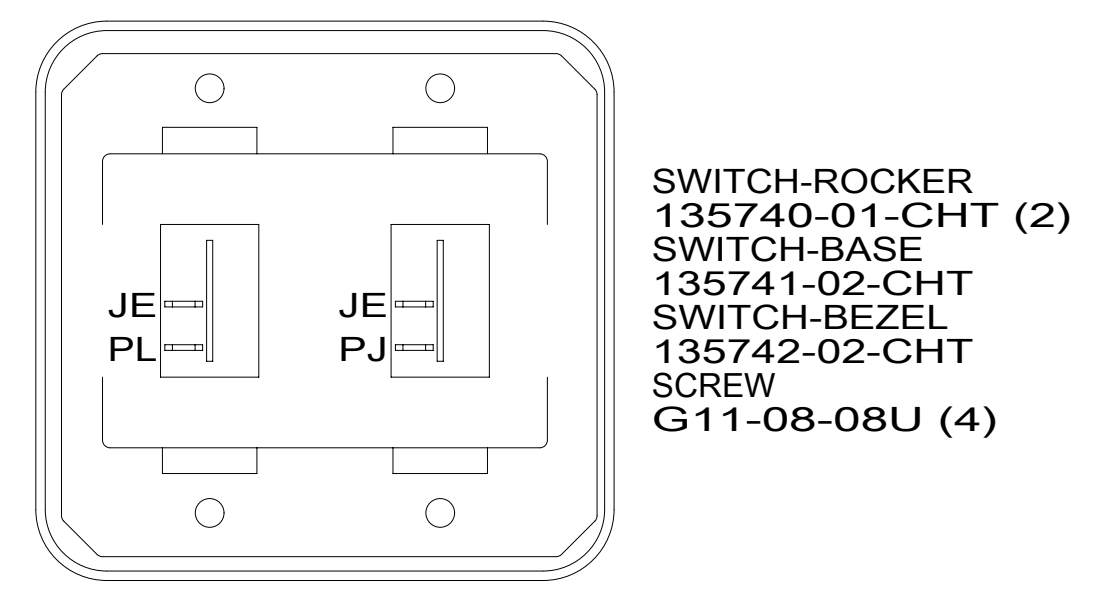

DETAIL CB

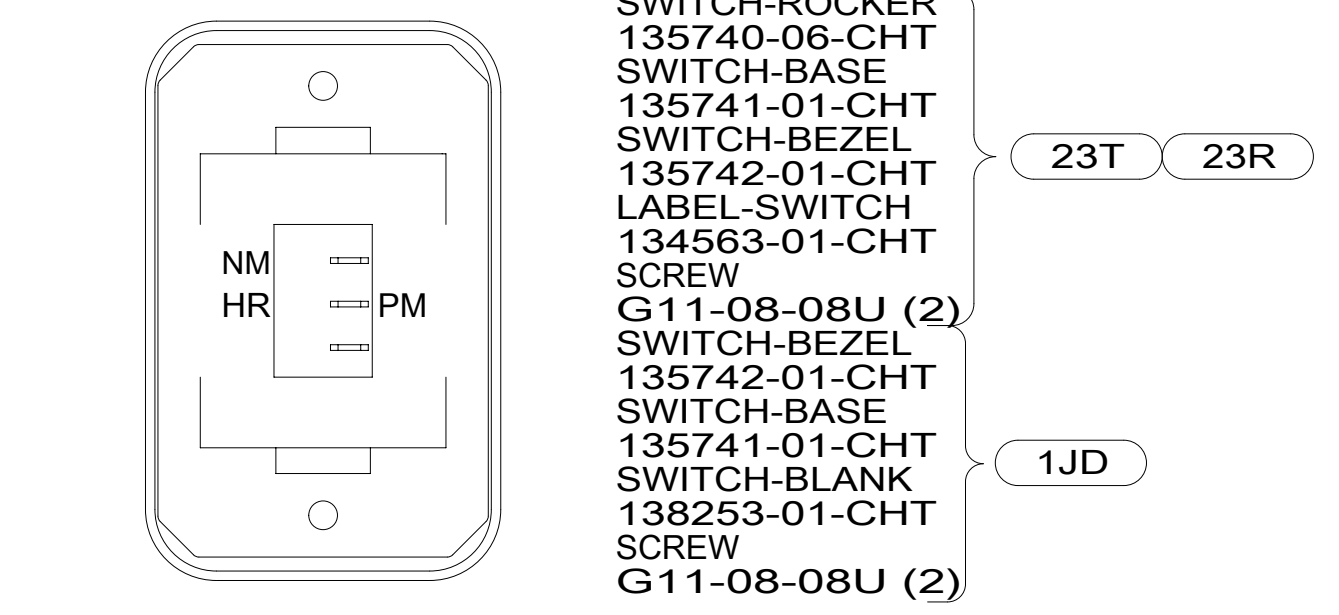

DETAIL CE

HOLDING TANK HEATER  
TURN OFF When Not In Use  
SEE OPERATORS MANUAL

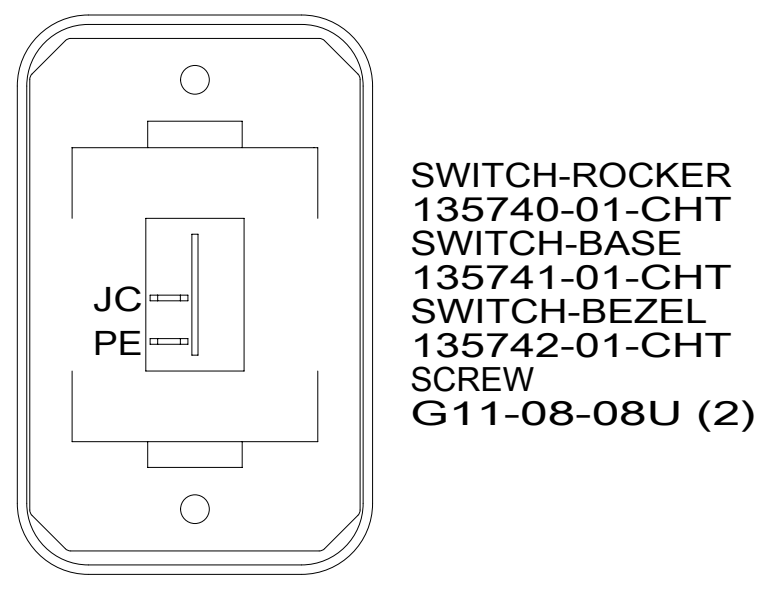

DETAIL CC

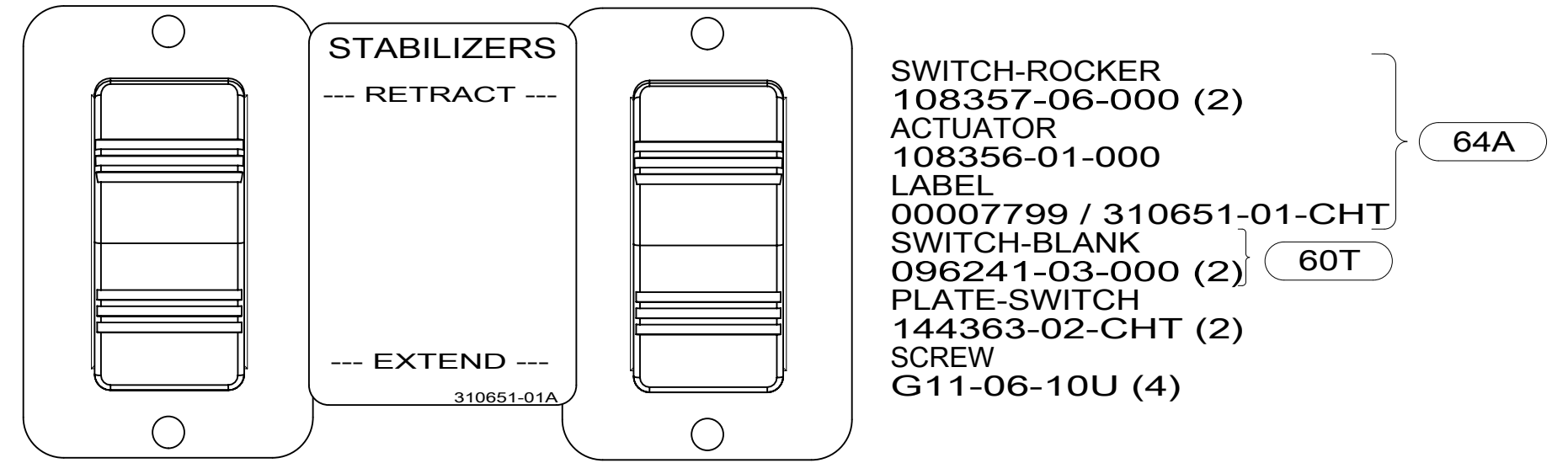

DETAIL CF

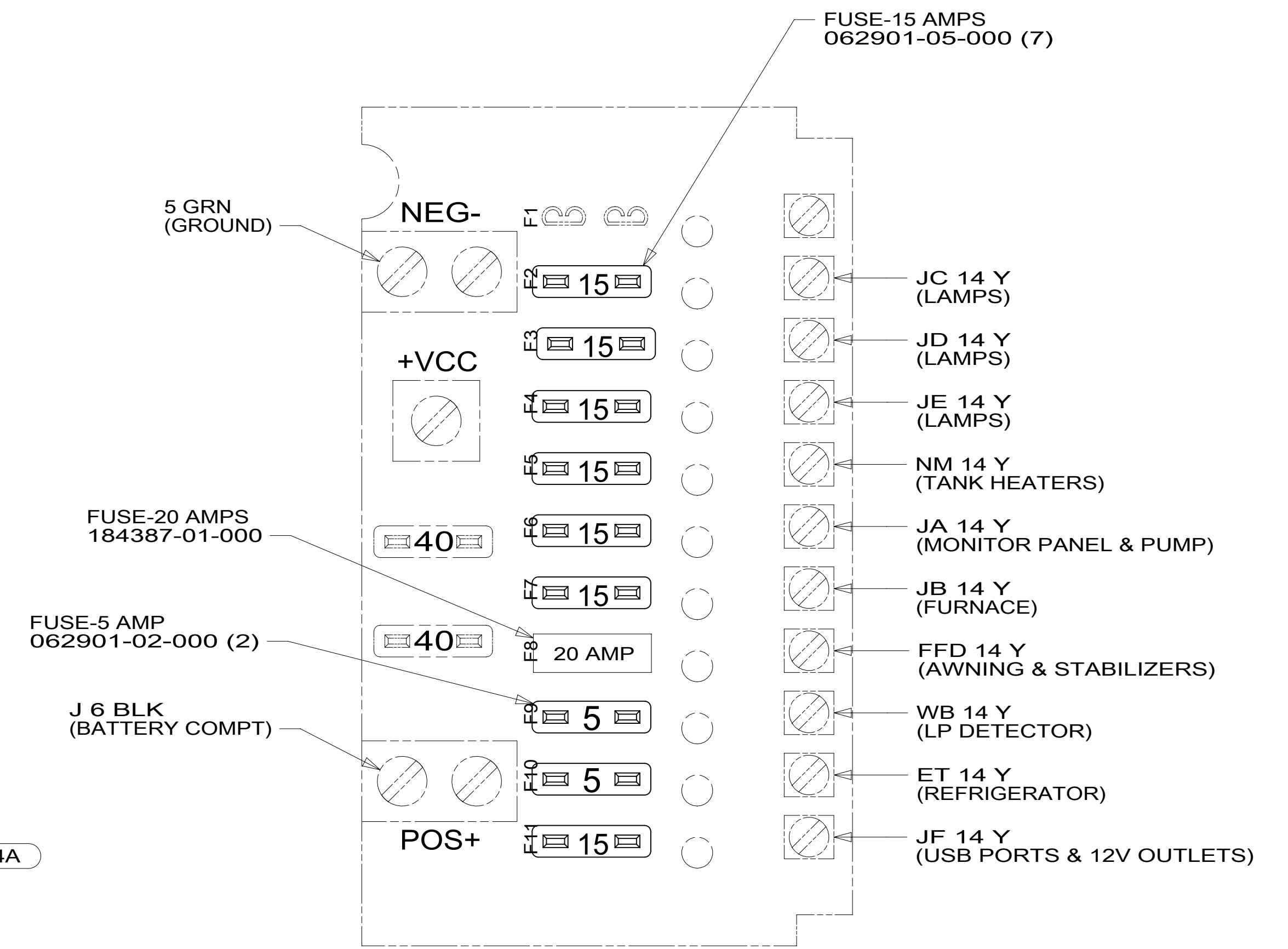

DETAIL CG

- 1JD DRAINAGE SYSTEM-HEATED-W/O
- 64A JACKS-STABILIZING, ELECTRIC
- 60T JACKS-STABILIZING,ELECT W/O
- 52F AWNING - PATIO
- 52N AWNING - PATIO, ELECTRIC
- 23R DRAINAGE SYSTEM/HEAT-PREWIRE
- 23T DRAINAGE SYSTEM-HEATED
- 265 CODES/STANDARDS-CSA/CMVSS
- 1B1 CODES/STANDARDS USA

FOR ELECTRICAL TORQUE SPECIFICATIONS SEE DWG NO. 128783-01-000

FOR ELECTRICAL CALLOUTS SEE DWG NO. 121339-01-000

DESCRIPTION: <b>WIRING INSTL-BODY, 12V</b>	
SHEET: <b>3 OF 4</b>	ITEM/PART NO: <b>000038564 / 31941501000</b>
REV	REV

LIGHT-LED,ROUND 4.5 PLASTIC  
 000166889 / 329926-01-CHT (6)  
 SCREW  
 G13-06-16U (18)  
 CONNECTOR  
 58028-01-000 (12)

LIGHT-LED,ROUND W/SWITCH,3.5 PLASTIC  
 000166892 / 329927-01-CHT  
 SCREW  
 G13-06-16U (3)  
 CONNECTOR  
 58028-01-000 (2)

ANTENNA-TV, OMNIDIRECTIONAL  
 000171487 / 331386-01-CHT  
 SCREW  
 G67-10-16U (4)

1J8 1

- 1J8 TV ANTENNA-OMNI DIRECTIONAL
- 265 CODES/STANDARDS-CSA/CMVSS
- 1B1 CODES/STANDARDS USA

1B1 265

FOR ELECTRICAL  
 TORQUE  
 SPECIFICATIONS  
 SEE DWG NO.  
 128783-01-000

FOR  
 ELECTRICAL  
 CALLOUTS  
 SEE DWG NO.  
 121339-01-000

DESCRIPTION: <b>WIRING INSTL-BODY, 12V</b>		
SHEET: <b>4 OF 4</b>	ITEM/PART NO: <b>000038564 / 31941501000</b>	REV

1 SEE ANTENNA INSTALLATION MANUAL FOR  
 CORRECT INSTALLATION PROCEDURE.

NOTES: