

- 6 SEE DRAINAGE SYSTEM INSTALLATION FOR ADDITIONAL INFORMATION.
- 5 WIRE ROUTED ALONG DRAINAGE PIPE AND CONNECTED TO PIPE WITH TIE-WIRE 8343-04-000.
- 4 SEE WIRING INSTL-TV/DVD FOR ADDITIONAL INFORMATION.
- 3 SEE SHEET 5 FOR ADDITIONAL INFORMATION.
- 2 CABLE TO BE ROUTED WITH WIRE ASM-LEFT FROM BEDROOM TV TO WIRE ASM-CHASSIS.

1. AT MINIMUM ALL WIRES TO BE SUPPORTED AND SECURED PER CODE REQUIREMENTS. USE CLAMP 10495 OR 10497 OR WIRE TIE 8343 OR 108046 AND SCREW G67-XX-XXX OR G56-XX-XXX AS APPROPRIATE FOR INSTALLATION.

NOTES:

- 23T DRAINAGE SYSTEM-HEATED
- 23R DRAINAGE SYSTEM/HEAT-PREWIRE
- 68X TV - BEDROOM
- 265 CODES/STANDARDS-CSA/CMVSS
- 1B1 CODES/STANDARDS USA

WINNEBAGO
COPYRIGHT 2016 WINNEBAGO INDUSTRIES, INC.

DSNR:		ALL DIMENSIONS ARE IN MILLIMETERS	
DIFFR:		18 331D	
UNSPECIFIED TOLERANCES:		WEIGHT: (LBS)	
WHOLE DIM (X)	3	FIRST USED:	
ONE-PLACE (X.X)	1.5		
TWO-PLACE (X.XX)	0.50		
ANGLE	1°		
REFER TO ES0018 FOR FASTENER TIGHTENING GUIDELINES			
DESCRIPTION:			
WIRING INSTL-BODY, 12V			
SHEET:	ITEM/PART NO:	REF:	REV:
1 OF 5	000038208 / 31875301000		

FOR ELECTRICAL TORQUE SPECIFICATIONS SEE DWG NO. 128783-01-000

FOR ELECTRICAL CALLOUTS SEE DWG NO. 121339-01-000

WARNING
 CRUSH HAZARD. Keep people and objects clear of the inside and outside of the slideout room when operating. Failure to comply could result in death or serious injury.

LABEL-WARNING, SLIDEOUT
 116549-02-000

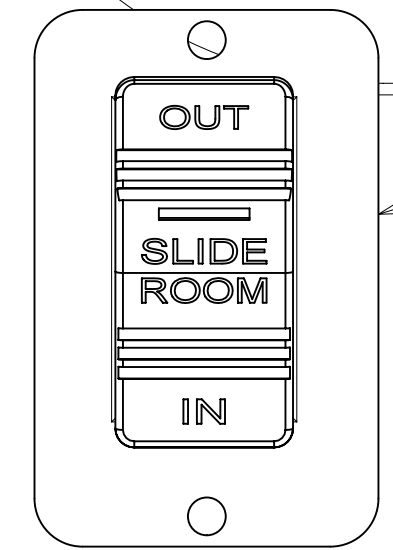

DETAIL CA

PLATE-SWITCH
 144363-02-CHT
 SWITCH
 108357-18-000
 ACTUATOR
 108356-31-CHT
 SCREW
 G11-08-08U (2)

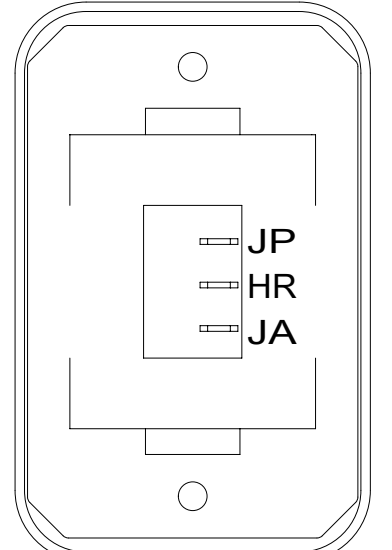

HOLDING TANK HEATER
 TURN OFF When Not In Use
 SEE OPERATORS MANUAL

DETAIL CF

SWITCH-ROCKER
 135740-06-CHT
 SWITCH-BASE
 135741-01-CHT
 SWITCH-BEZEL
 135742-01-CHT
 SCREW
 G11-08-08U (2)
 LABEL-SWITCH,
 HTR,HOLDING TK
 134563-01-CHT
 SWITCH-BASE
 135741-01-CHT
 SWITCH-BEZEL
 135742-01-CHT
 SWITCH-BLANK
 138253-01-CHT
 SCREW
 G11-08-08U (2)

23T 23R
 1JD

52N
 52F

SWITCH-ROCKER
 108357-06-000
 ACTUATOR-SWITCH
 108356-12-CHT
 SWITCH-BLANK
 096241-03-000

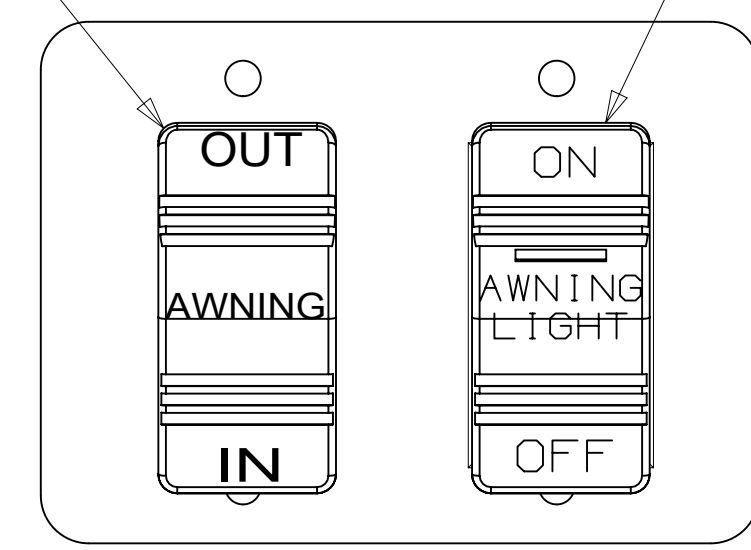

DETAIL CD

SWITCH-ROCKER
 108357-14-000
 ACTUATOR-SWITCH
 108356-28-CHT
 SWITCH-BLANK
 096241-03-000

52N
 52F

PLATE-SWITCH
 158431-17-CHT
 SCREW
 G11-06-10U (4)

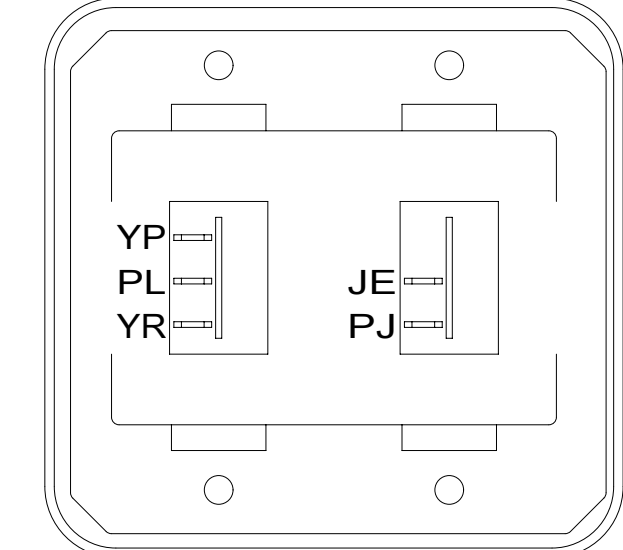

DETAIL CB

SWITCH-ROCKER
 135740-01-CHT
 135740-02-CHT
 SWITCH-BASE
 135741-02-CHT
 SWITCH-BEZEL
 135742-02-CHT
 SCREW
 G11-08-08U (4)

SWITCH-ROCKER
 108357-18-000
 ACTUATOR-SWITCH,
 SLIDE ROOM
 108356-31-CHT
 PLATE-SWITCH
 144363-02-CHT
 SCREW
 G11-08-08U (2)

LABEL-WARNING,SLIDEOUT
 116549-02-000

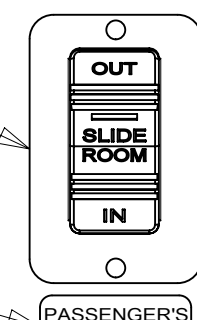

SWITCH
 DETAIL CF

WARNING
 CRUSH HAZARD. Keep people and objects clear of the inside and outside of the slideout room when operating. Failure to comply could result in death or serious injury.

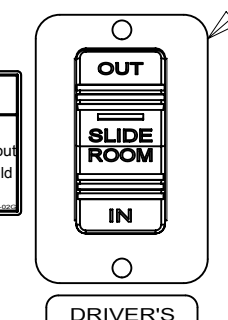

SWITCH-ROCKER
 108357-18-000
 ACTUATOR-SWITCH,
 SLIDE ROOM
 108356-31-CHT
 PLATE-SWITCH
 144363-02-CHT
 SCREW
 G11-08-08U (2)

LABEL-SLIDEOUT,
 DRIVER,FRONT
 163992-01-CHT

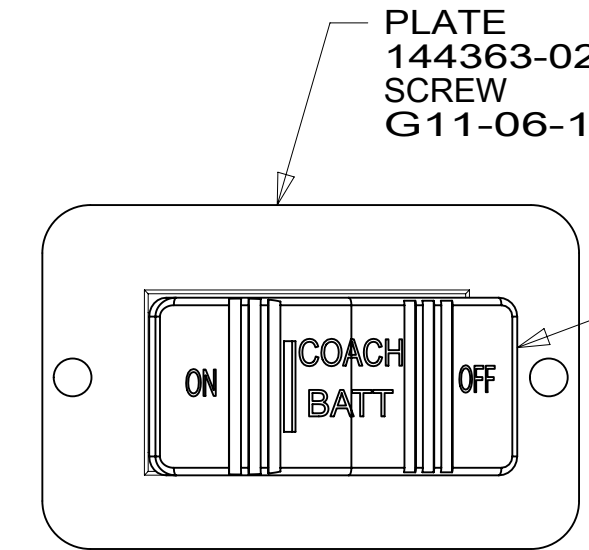

DETAIL CG

PLATE
 144363-02-CHT
 SCREW
 G11-06-10U (4)

SWITCH-BATTERY
 108357-18-000
 ACTUATOR
 108356-19-CHT
 CIRCUITS LH,LJ,
 LG,JP,JA
 WIRE ASM-THERMISTOR
 186796-01-000

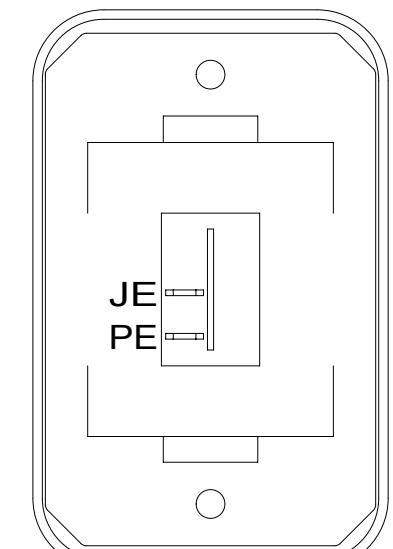

DETAIL CC

SWITCH-ROCKER
 135740-01-CHT
 SWITCH-BASE
 135741-01-CHT
 SWITCH-BEZEL
 135742-01-CHT
 SCREW
 G11-08-08U (2)

FUSE-15 AMP
 062901-05-000 (8)

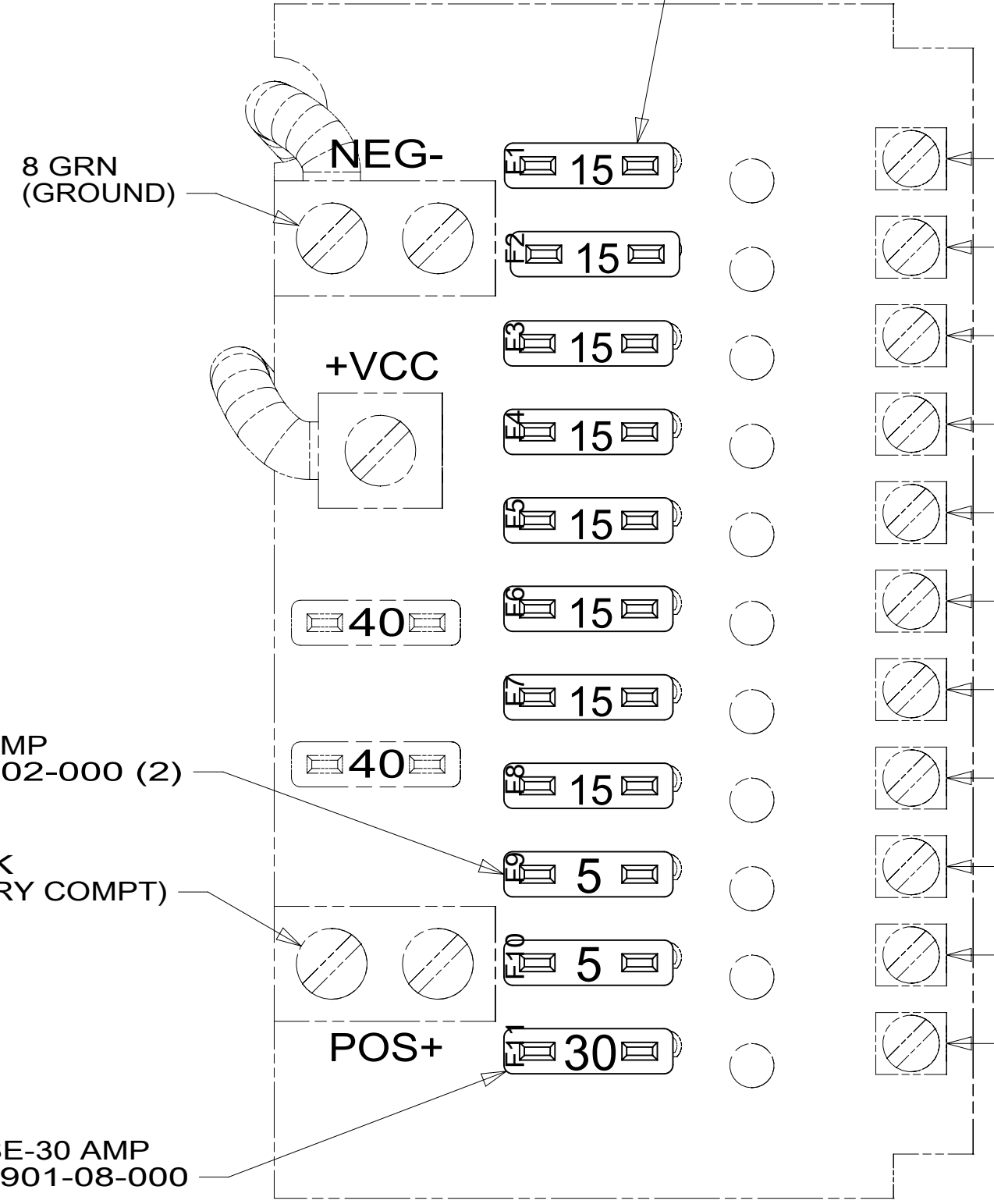

DETAIL CH

- JC 14 Y (LAMPS)(EXT TV)
- JD 14 Y (LAMPS)(TV/DVD)
- JE 14 Y (LAMPS)
- JF 14 Y (USB PORTS & LAMPS)
- NM 12 Y (TANK HEATERS)
- JA 14 Y (MONITOR PANEL & PUMP)
- JB 14 Y (FURNACE)
- FFD 12 Y (AWNING)
- WB 16 Y (LP DETECTOR)
- ET 16 Y (REFRIGERATOR)
- XXV 10 Y (REAR SLIDEOUTS)

FUSE-5 AMP
 062901-02-000 (2)

J 6 BLK
 (BATTERY COMPT)

FUSE-30 AMP
 062901-08-000

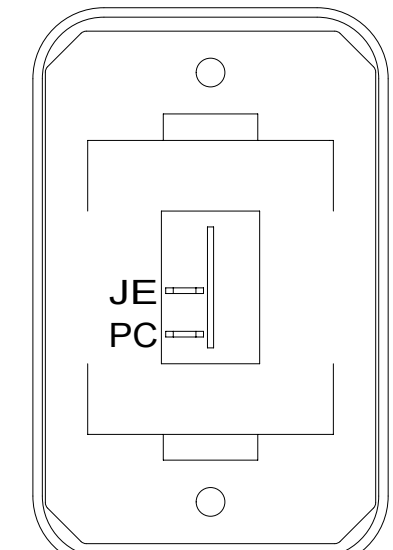

DETAIL CK

SWITCH-ROCKER
 135740-01-CHT
 SWITCH-BASE
 135741-01-CHT
 SWITCH-BEZEL
 135742-01-CHT
 SCREW
 G11-08-08U (2)

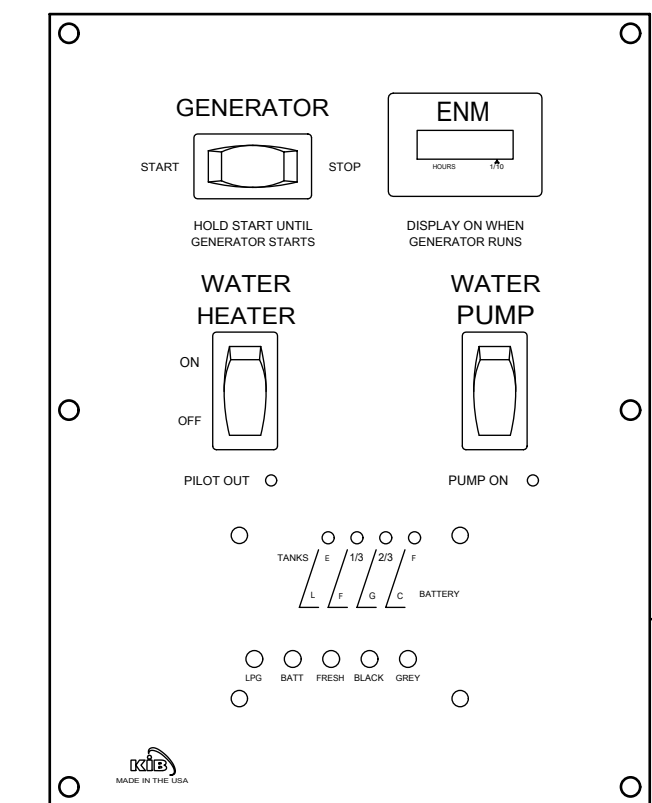

DETAIL CE

REMOTE PANEL-INVERTER
 000037772 / 318694-01-CHT
 (SUPPLIED W/ INVERTER)
 SCREW
 000G11-06-08U (2)
 CABLE-DATA
 000038251/318769-02-000

401

SWITCH-ROCKER
 135741-01-CHT
 SWITCH-BASE
 135742-01-CHT
 SWITCH-BEZEL
 135742-01-CHT
 SCREW
 G11-08-08U (2)
 SWITCH-BLANK
 138253-01-CHT

40A

PANEL-MONITOR, W/GEN
 000167995 / 330356-01-CHT

THERMOSTAT-
 A/C AND HEAT
 135618-06-CHT
 SCREW
 G13-07-12U (2)

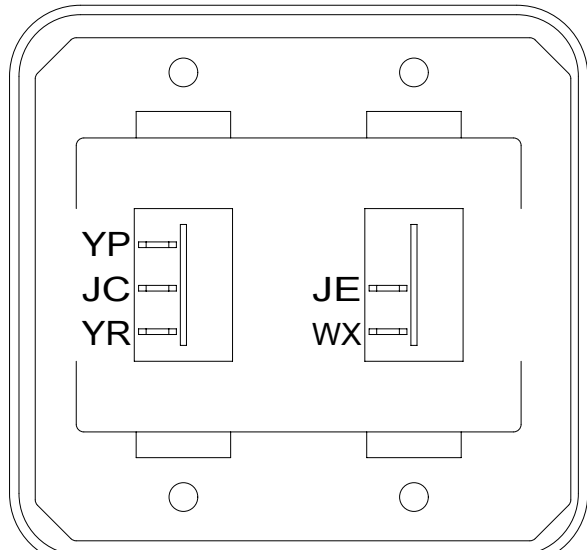

DETAIL CJ

SWITCH-ROCKER
 135740-01-CHT
 135740-02-CHT
 SWITCH-BASE
 135741-02-CHT
 SWITCH-BEZEL
 135742-02-CHT
 SCREW
 G11-08-08U (4)

- 1JD DRAINAGE SYSTEM-HEATED-W/O
- 40A INVERTER-DC/AC WITHOUT
- 401 INVERTER-DC/AC, 1000 WATT
- 52F AWNING-PATIO
- 52N AWNING - PATIO, ELECTRIC
- 23R DRAINAGE SYSTEM/HEAT-PREWIRE
- 23T DRAINAGE SYSTEM-HEATED
- 265 CODES/STANDARDS-CSA/CMVSS
- 1B1 CODES/STANDARDS USA

FOR ELECTRICAL
 TORQUE
 SPECIFICATIONS
 SEE DWG NO.
 128783-01-000

FOR ELECTRICAL
 CALLOUTS
 SEE DWG NO.
 121339-01-000

1B1 265

DESCRIPTION: WIRING INSTL-BODY, 12V		
SHEET: 3 OF 5	ITEM/PART NO: 000038208 / 31875301000	REV

8 7 6 5 4 3 2 1

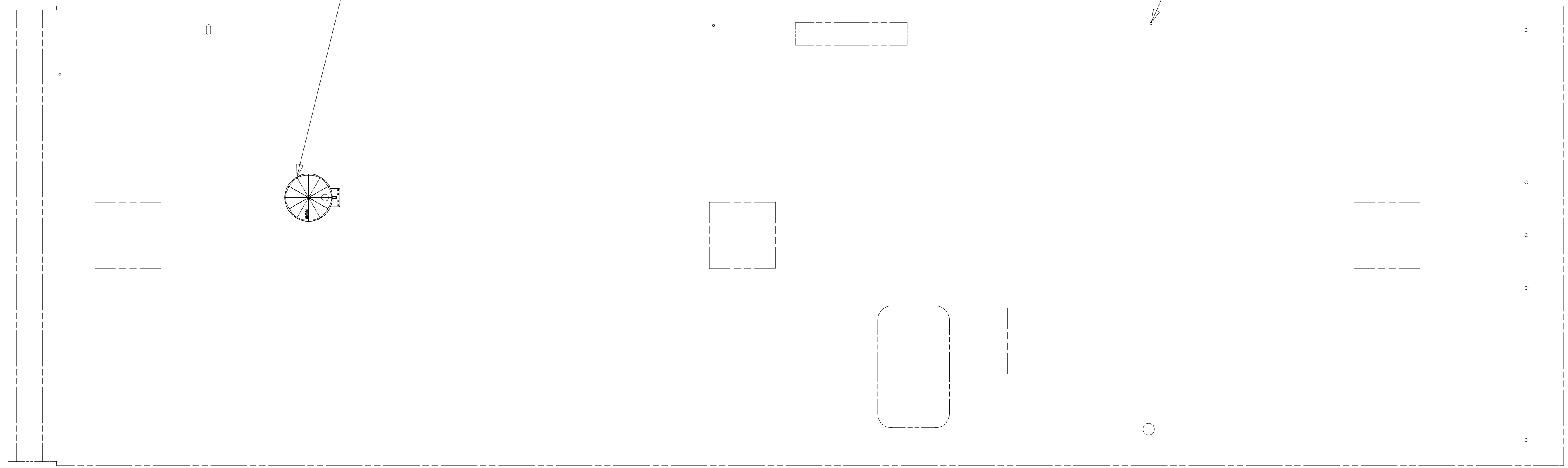
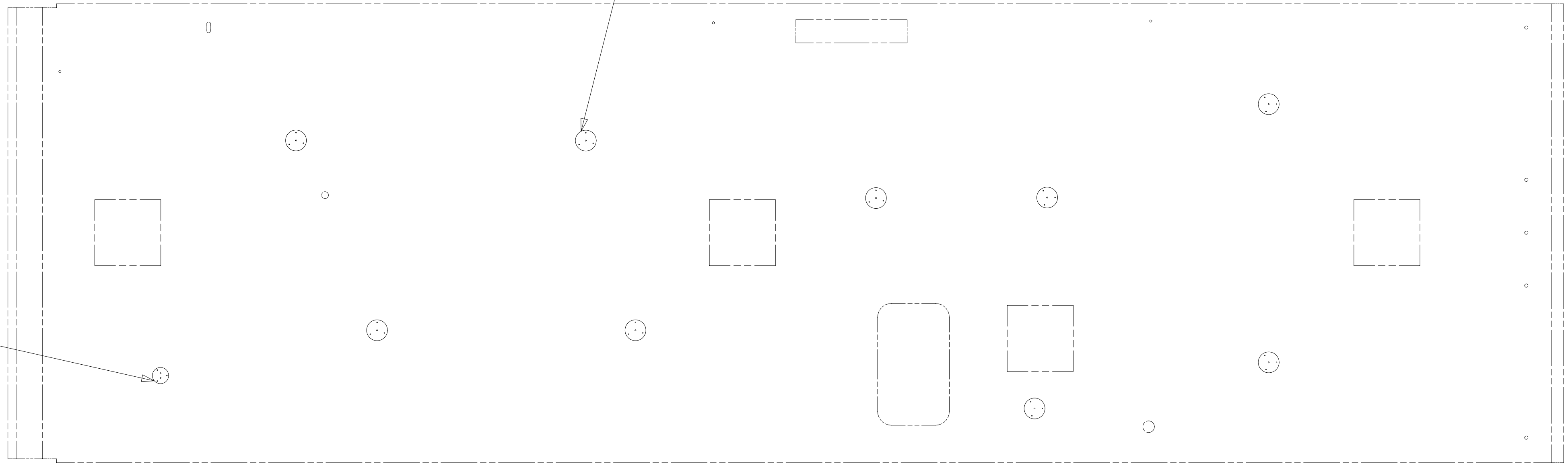

LIGHT-LED, ROUND W/SWITCH, 3.5 PLASTIC
 000166892 / 329927-01-CHT
 SCREW
 G13-06-16U (3)
 CONNECTOR
 58028-01-000 (2)

LIGHT-LED, ROUND 4.5 PLASTIC
 000166889 / 329926-01-CHT (9)
 SCREW
 G13-06-16U (27)
 CONNECTOR
 58028-01-000 (18)

ANTENNA-TV, OMNIDIRECTIONAL, PORTABLE
 000120035 / 323063-01-CHT
 SCREW
 G67-10-16U (3)
 PLATE-ROOF, CABLE ENTRY
 146488-01-000
 SCREW
 G67-10-10U (10)

ANTENNA-RADIO 1D3 2

2 SEE ENTERTAINMENT CTR COMPL-TV FOR ADDITIONAL INFORMATION.
 1 SEE ANTENNA INSTALLATION MANUAL FOR CORRECT INSTALLATION PROCEDURE.

FOR ELECTRICAL TORQUE SPECIFICATIONS SEE DWG NO. 128783-01-000

FOR ELECTRICAL CALLOUTS SEE DWG NO. 121339-01-000

- 1J8 TV ANTENNA-OMNI DIRECTIONAL
- 1D3 ENTERTAIN CENTR/EXT TV-DVD
- 265 CODES/STANDARDS-CSA/CMVSS
- 1B1 CODES/STANDARDS USA

DESCRIPTION:		WIRING INSTL-BODY, 12V	
SHEET:	ITEM/PART NO.:	REV:	
4 OF 5	000038208 / 31875301000		

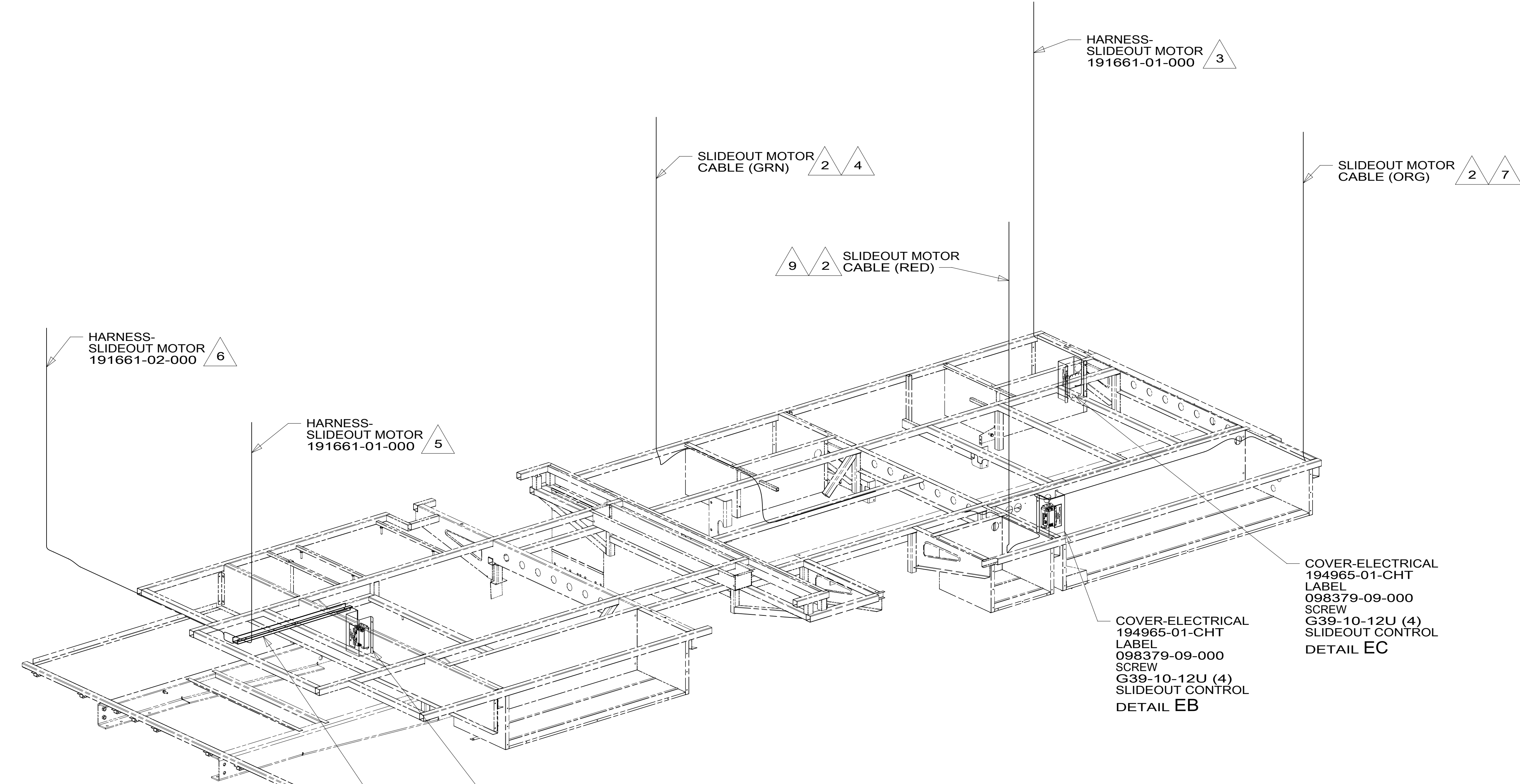
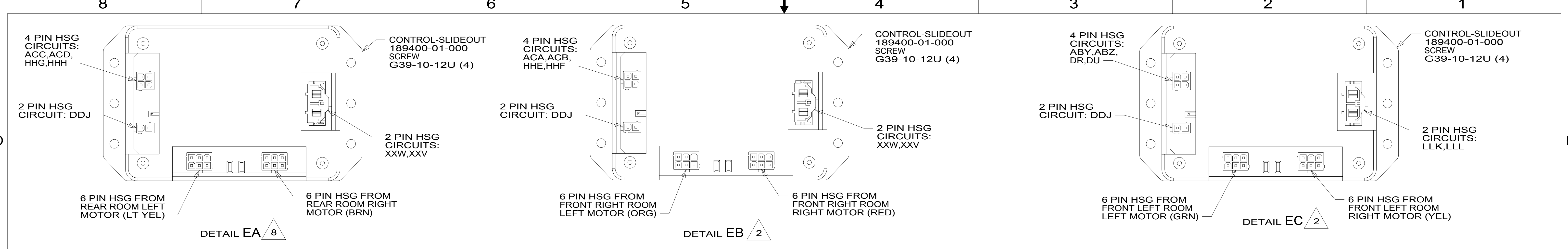

- 9 CABLE MARKED WITH RED TAPE.
- 8 WIRING PART OF WIRE ASM-RIGHT.
- 7 CABLE MARKED WITH ORANGE TAPE.
- 6 CABLE MARKED WITH BROWN TAPE.
- 5 CABLE MARKED WITH LIGHT YELLOW TAPE.
- 4 CABLE MARKED WITH GREEN TAPE.
- 3 CABLE MARKED WITH YELLOW TAPE.
- 2 WIRING PART OF WIRE ASM-CHASSIS.

NOTES:
 1. ROUTE TANK SENSOR WIRES SO THEY DO NOT PASS OVER SENSORS. USE WIRE TIE MOUNT 155366-01-000 AS NEEDED. TANK SURFACE MUST BE CLEANED USING ISOPROPYL ALCOHOL AND PRIME WITH PRIMER 94.

FOR ELECTRICAL TORQUE SPECIFICATIONS SEE DWG NO. 128783-01-000

FOR ELECTRICAL CALLOUTS SEE DWG NO. 121339-01-000

- 23T DRAINAGE SYSTEM-HEATED
- 23R DRAINAGE SYSTEM/HEAT-PREWIRED
- 265 CODES/STANDARDS-CSA/CMVSS
- 1B1 CODES/STANDARDS USA

DESCRIPTION: WIRING INSTL-BODY, 12V	
SHEET: 5 OF 5	ITEM/PART NO: 000038208 / 31875301000
REV 1 06-Sep-2018	