

8 7 6 5 4 3 2 1

D
C
B
A

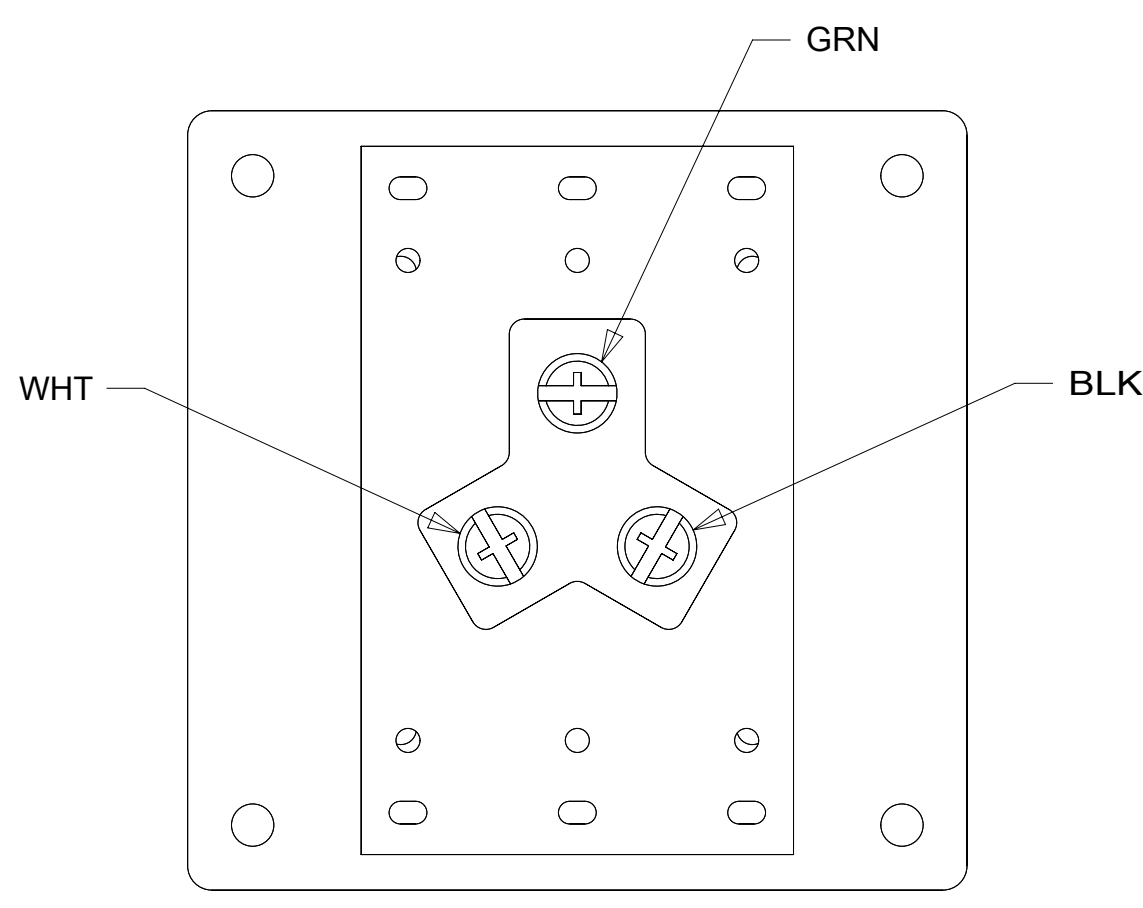
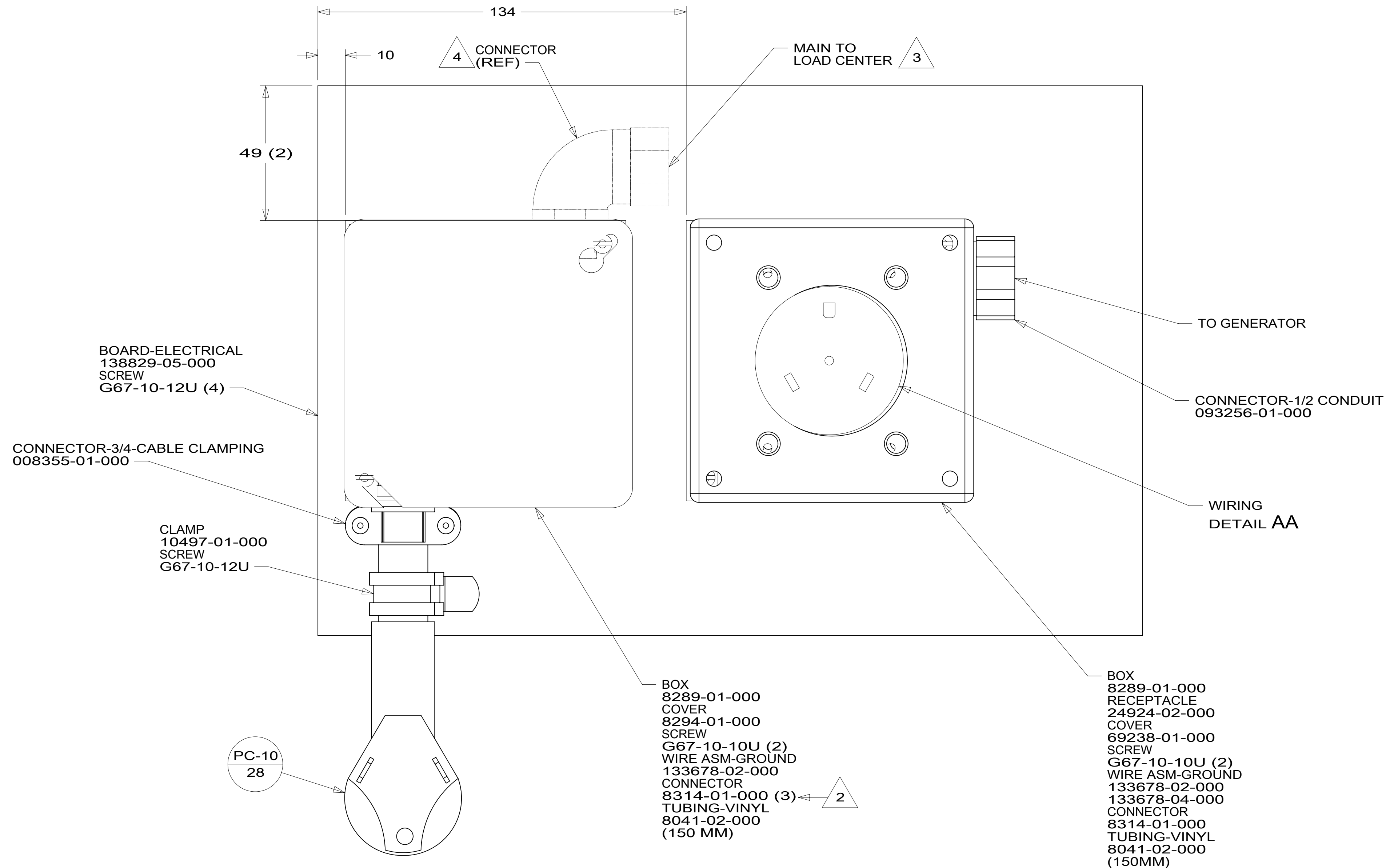

DETAIL AA (BACK VIEW)

- 4 CONNECTOR IS PART OF MAIN CABLE ASM.
 - 3 SEE WIRING INSTL-BODY, 110V FOR ADDITIONAL INFORMATION.
 - 2 CONNECT BLK TO BLK, WHT TO WHT, AND GRNDS TO GRNDS.
1. ALL GROUND WIRES TO BE COVERED WITH TUBING 8041-02-000.

NOTES:

FOR ELECTRICAL TORQUE SPECIFICATIONS SEE DWG NO. 128783-01-000

FOR ELECTRICAL CALLOUTS SEE DWG NO. 121339-01-000

- 093 PREMIUM PACKAGE WITHOUT
- 265 CODES/STANDARDS-CSA/CMVSS
- 1B1 CODES/STANDARDS USA

1B1 265 093

WINNEBAGO
COPYRIGHT 2016 WINNEBAGO INDUSTRIES, INC.

DSNR:	ALL DIMENSIONS ARE IN MILLIMETERS	
DFFR:		
UNSPECIFIED TOLERANCES:	MATERIAL:	
WHOLE DIM (X) :	3	
ONE-PLACE (X.X) :	1.5	
TWO-PLACE (X.XX) :	0.50	
ANGLE :	1°	
REFER TO ES0018 FOR FASTENER TIGHTENING GUIDELINES	WEIGHT: (LBS)	FIRST USED: 18 331D
DESCRIPTION: POWER CORD BOX ASM		
SHEET: 1 OF 1	ITEM/PART NO: 000037765 / 31866001000	REV:

8 7 6 5 4 3 2 1