

8 7 6 5 4 3 2 1

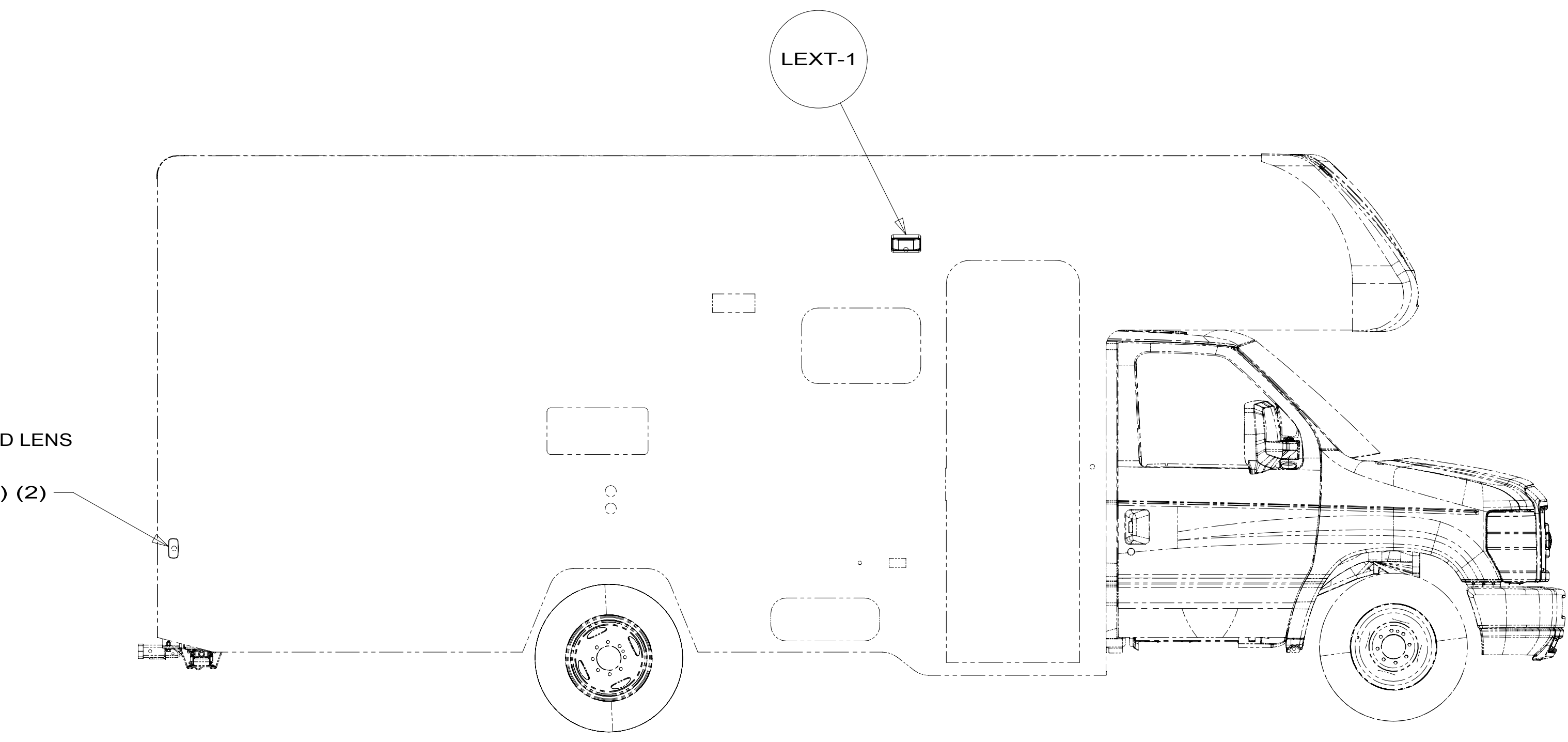

LAMP-MARKER, W/RED LENS  
193802-04-000  
SCREW  
G11-08-12U (EXT) (2)

LEXT-1

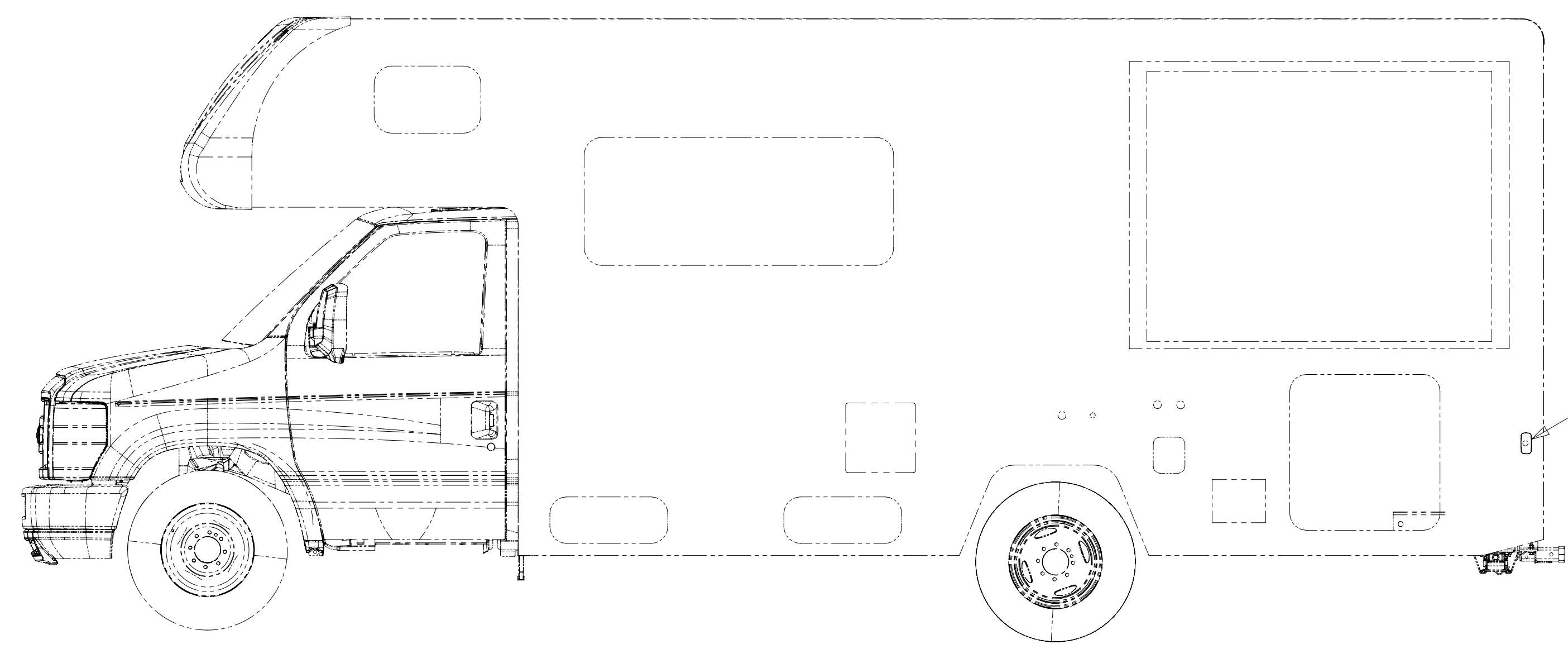

LAMP-MARKER, W/RED LENS  
193802-04-000  
SCREW  
G11-08-12U (EXT) (2)

- 265 CODES/STANDARDS-CSA/CMVSS
- 1B1 CODES/STANDARDS USA
- 1B1 265



DSNR:		ALL DIMENSIONS ARE IN MILLIMETERS	
DIFFR:		MATERIAL:	
UNSPECIFIED TOLERANCES:			
WHOLE DIM (X)	± 3		
ONE-PLACE (X.X)	± 1.5		
TWO-PLACE (X.XX)	± 0.50		
ANGLE	± 1°		

REFER TO ES0018 FOR FASTENER TIGHTENING GUIDELINES

WEIGHT: (LBS)	FIRST USED:
	18 322M

DESCRIPTION:  
**WIRING INSTL-EXTERIOR LAMPS**

SHEET:	ITEM/PART NO.:	REV
1 OF 2	000030342 / 31667801000	

FOR ELECTRICAL TORQUE SPECIFICATIONS SEE DWG NO. 128783-01-000

FOR ELECTRICAL CALLOUTS SEE DWG NO. 121339-01-000

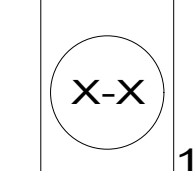

8 7 6 5 4 3 2 1

8 7 6 5 4 3 2 1

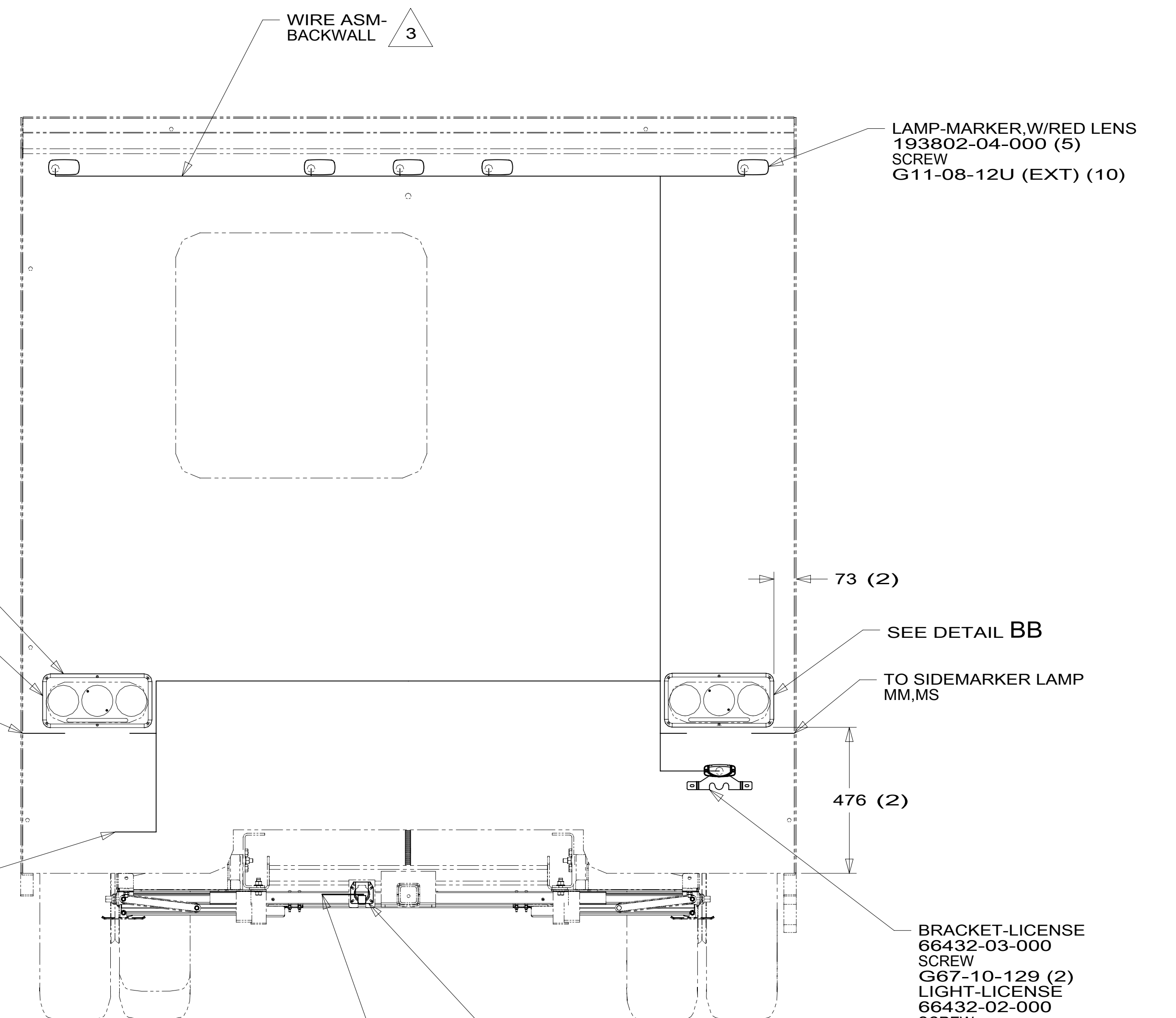
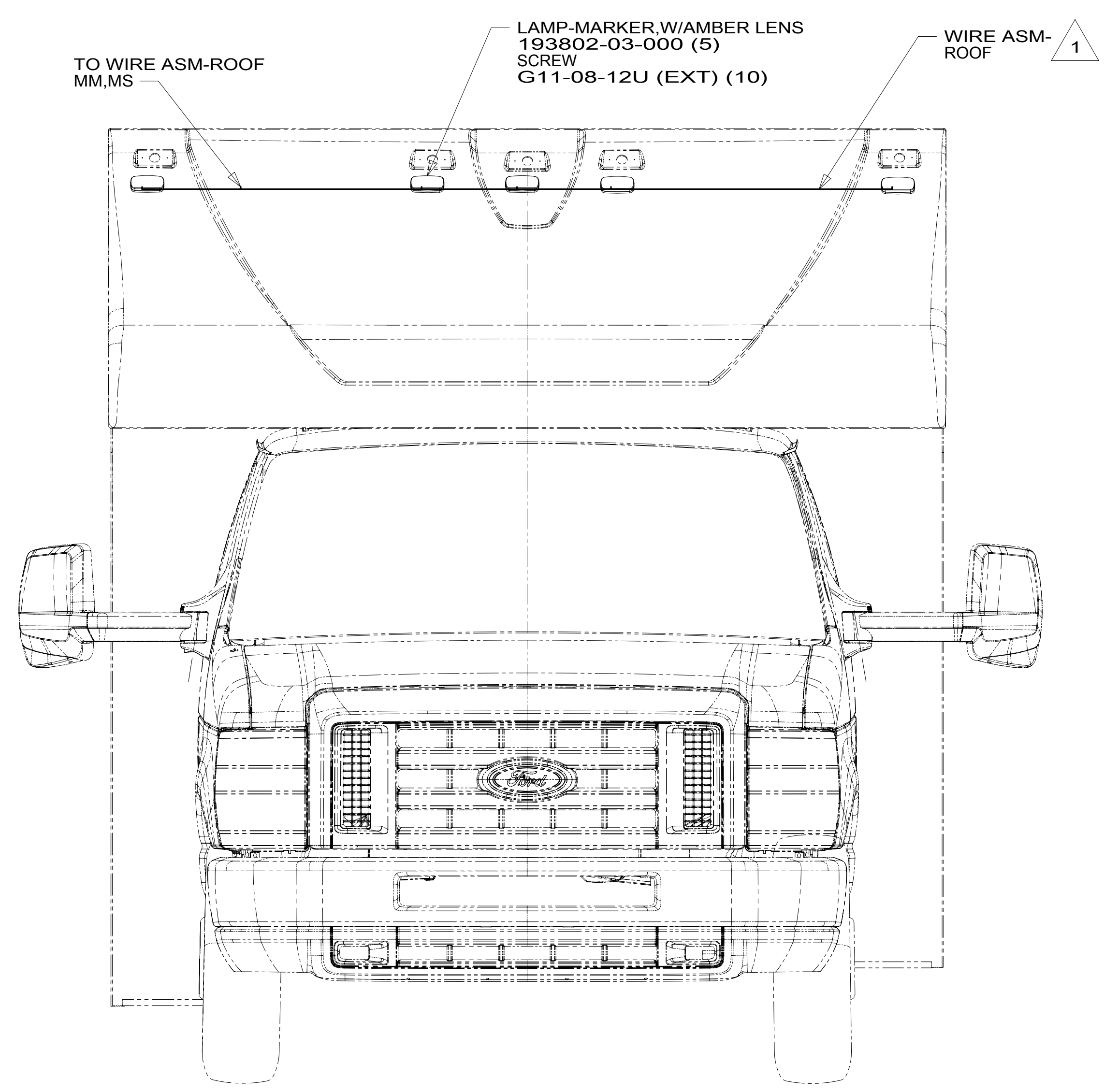

4 LAMP ASM-STOP/TURN/  
TAIL/BACKUP  
183787-01-000 (2)  
SCREW  
G11-07-12U (12)  
CONNECTOR  
58028-01-000 (8)

SEE DETAIL BA

TO SIDEMARKER LAMP  
MM,MS

8-PIN HOUSING  
TO WIRE ASM-CHASSIS

CONNECTOR-TRAILER  
157593-01-000  
SCREW  
101618-01-000 (4)

WIRE ASM-CHASSIS 2

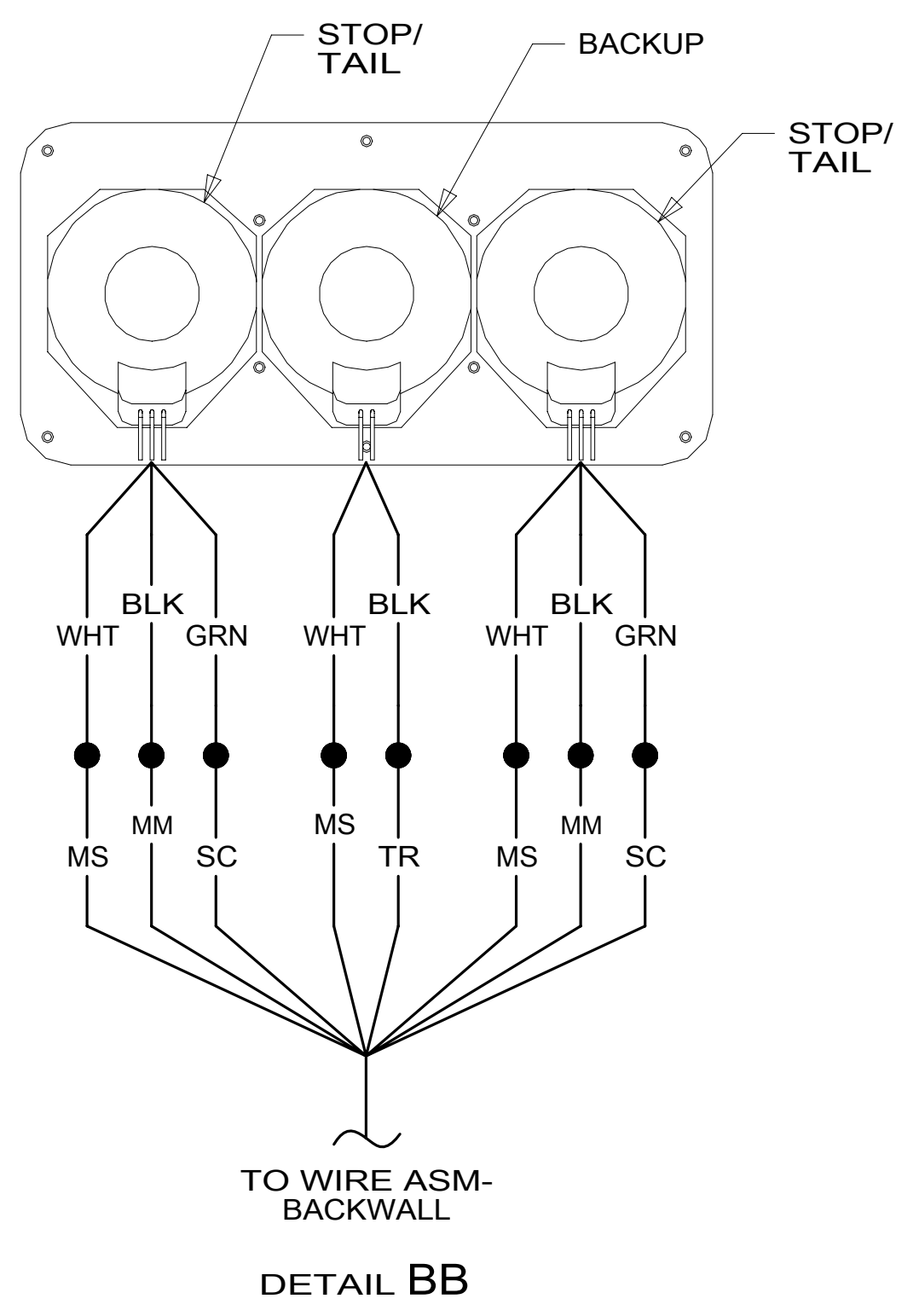
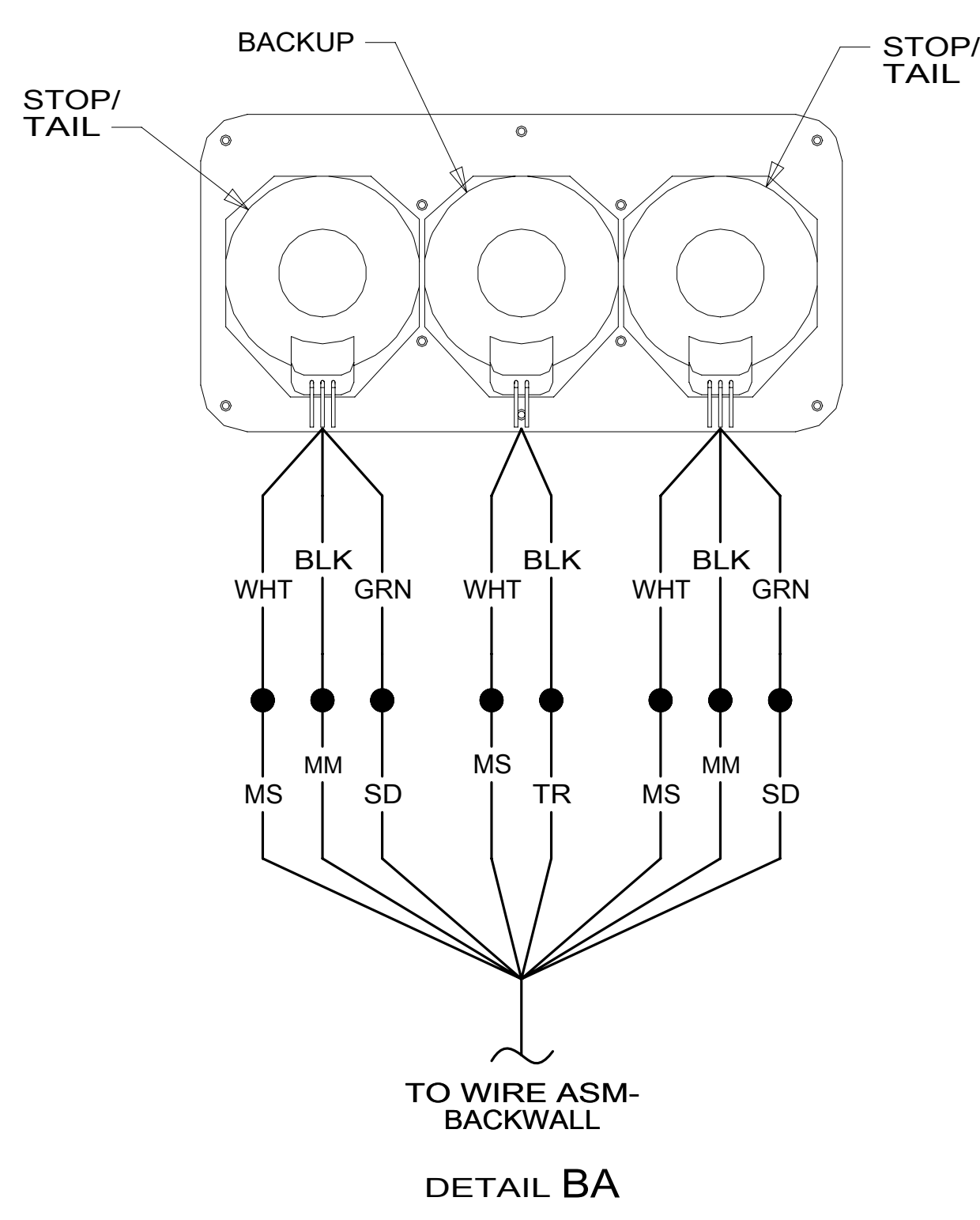

- NOTES:
- 4 TAIL LAMP MUST BE INSTALLED WITH WIRES DOWN.
  - 3 LOCATED IN BACKWALL ASSEMBLY.
  - 2 SECURE WIRE BELOW COACH WITH CLAMP 10495-01-000 AND SCREW G67-10-12B.
  - 1 LOCATED IN ROOF ASSEMBLY FRONT.

FOR ELECTRICAL TORQUE SPECIFICATIONS SEE DWG NO. 128783-01-000

FOR ELECTRICAL CALLOUTS SEE DWG NO. 121339-01-000

- 265 CODES/STANDARDS-CSA/CMVSS
- 1B1 CODES/STANDARDS USA

DESCRIPTION:		1B1 265
<b>WIRING INSTL-EXTERIOR LAMPS</b>		
SHEET:	ITEM/PART NO.:	REV
2 OF 2	000030342 / 31667801000	

8 7 6 5 4 3 2 1 27-Jun-2017