

LABEL-STABILIZER DOWN
000007625 / 310619-01-CHT

STABILIZER DOWN

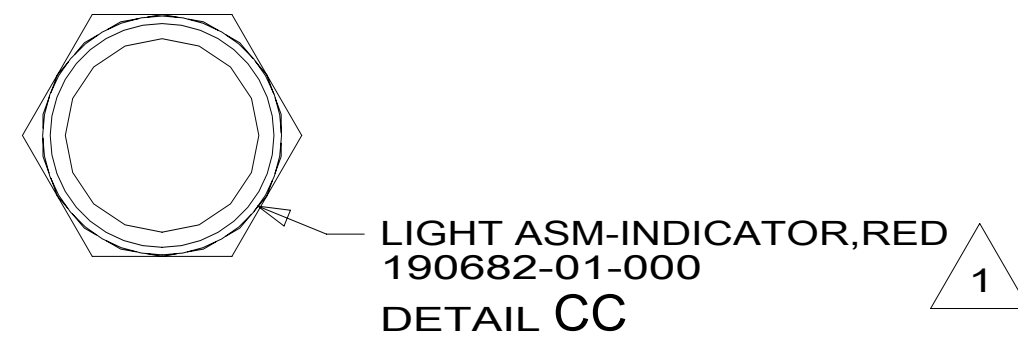

DETAIL CA 64A

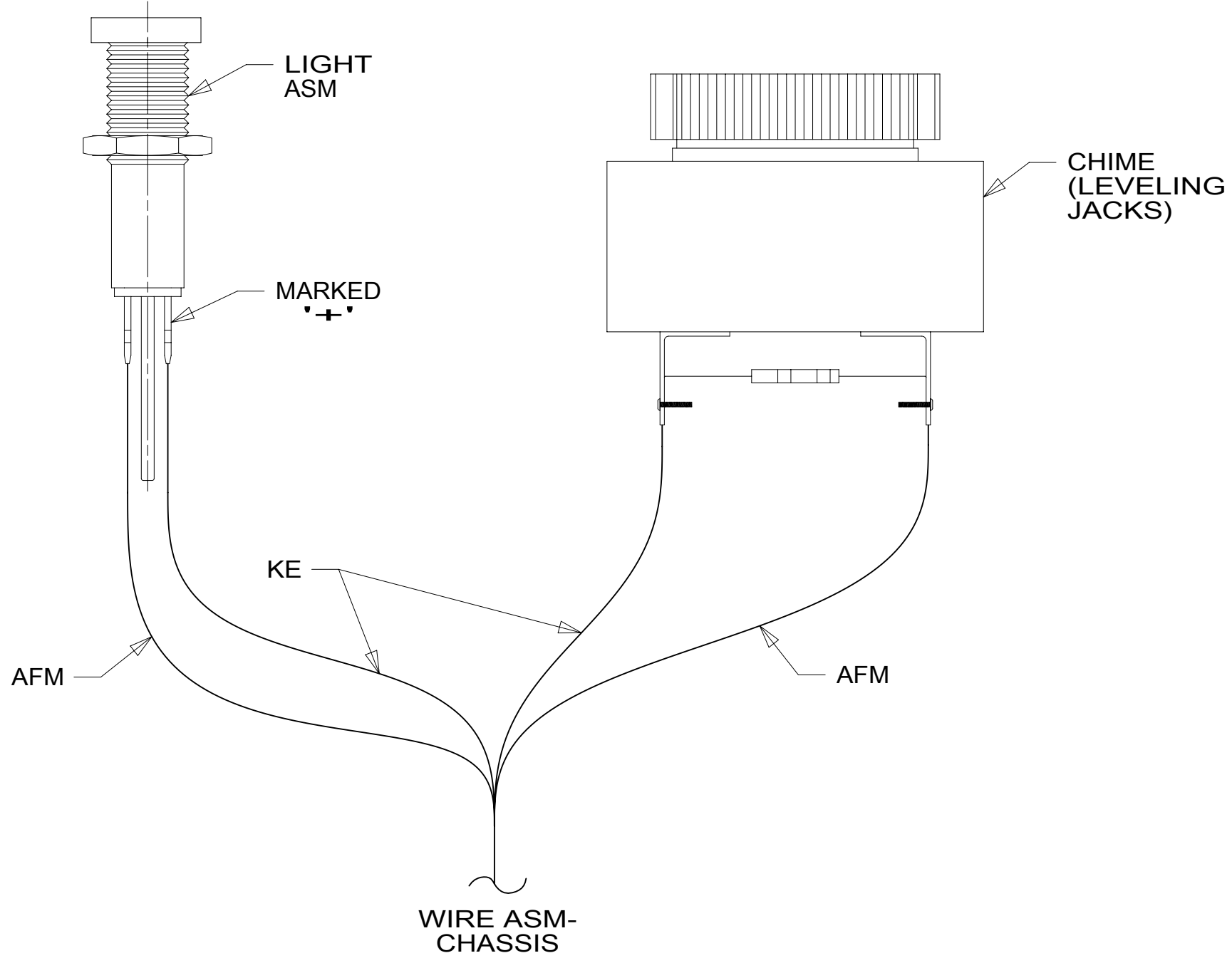

DETAIL CC 64A

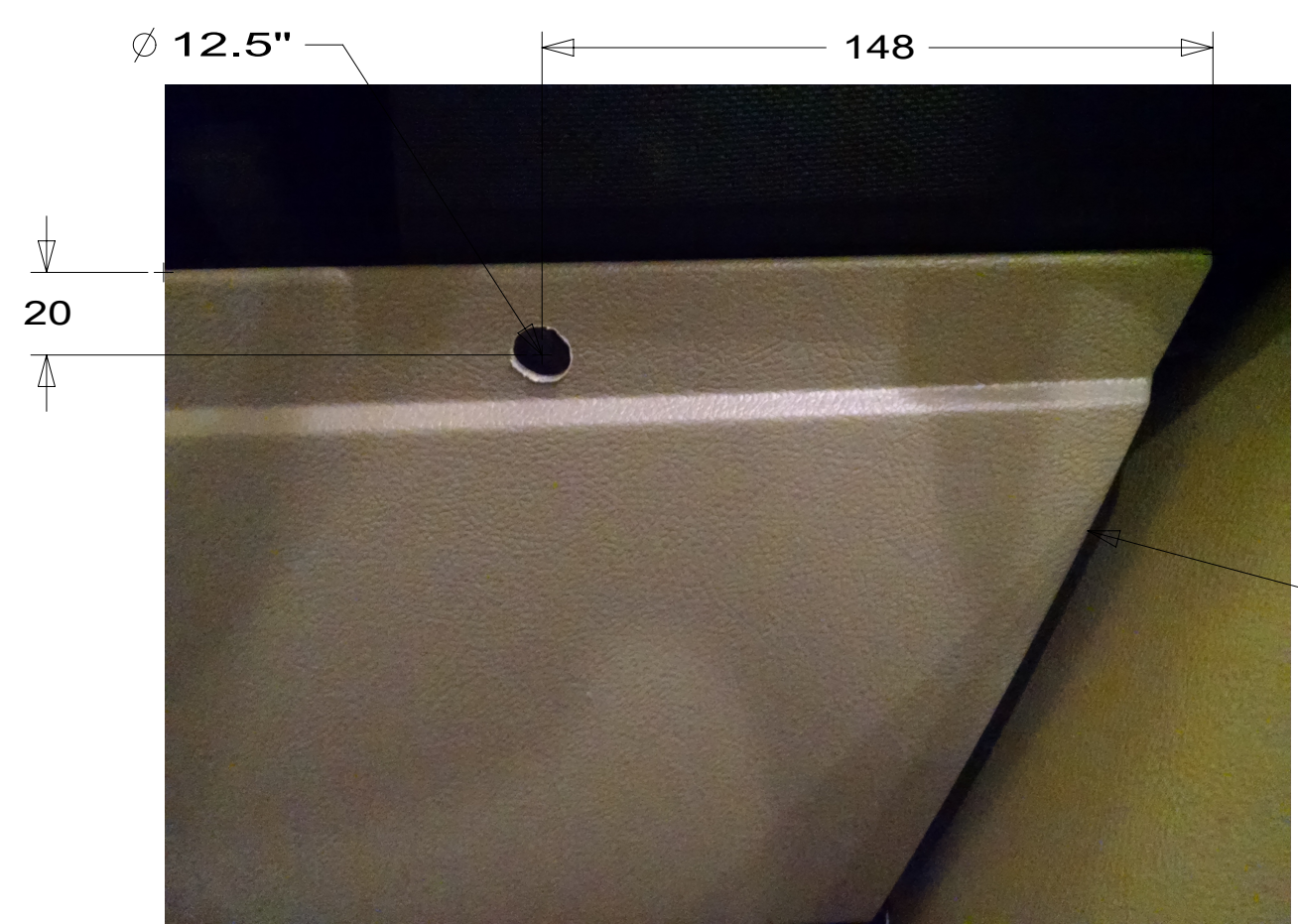

DETAIL CB 64A

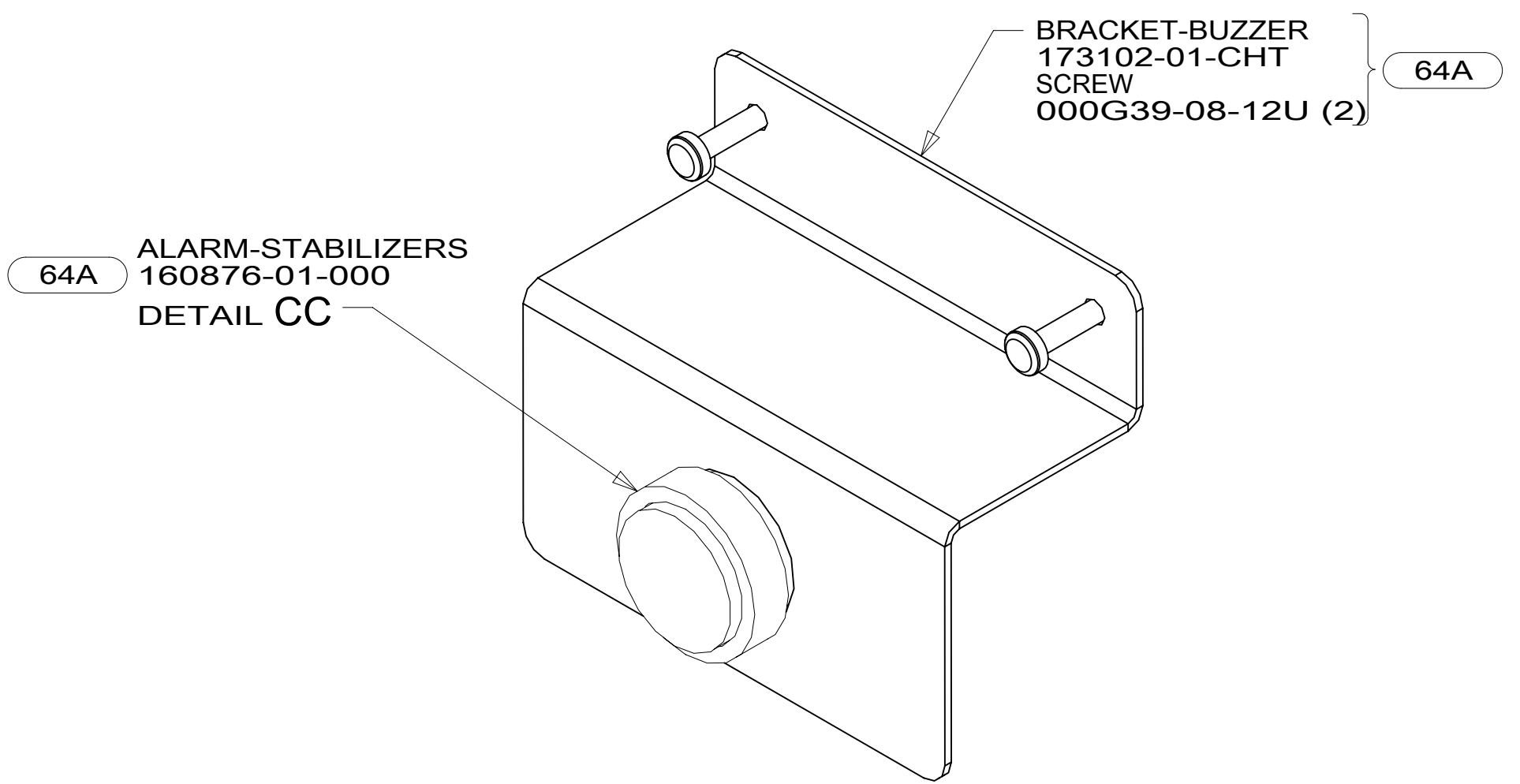

DETAIL CD

- 64A JACKS-STABILIZING, ELECTRIC
- 265 CODES/STANDARDS-CSA/CMVSS
- 1B1 CODES/STANDARDS USA

1 FOR HOLE SIZE AND LOCATION SEE DETAIL CB.
NOTES:

FOR ELECTRICAL TORQUE SPECIFICATIONS SEE DWG NO. 128783-01-000

FOR ELECTRICAL CALLOUTS SEE DWG NO. 121339-01-000

DESCRIPTION:		1B1 265	
WIRING INSTL-CHASSIS			
SHEET:	ITEM/PART NO.:	REV	
3 OF 3	000030226 / 31663901000		