

- 9 MHP TO INSTALL ON VALVE STEMS PER MANUFACTURING INSTRUCTIONS.
- 8 MOUNT ANTENNA WITH SUPPLIED BRACKET AND SCREWS. ROUTE ANTENNA WIRE ALONG D/S FRAME RAIL AND SECURE WITH OTHER LOOMS. ROUTE UP D/S A-PILLAR AND COIL EXCESS WITH INFOTAINMENT CORE WIRING CONNECTORS.
- 7 REST WIRE IN FRAME RAIL WHEN APPLICABLE.
- 6 CLAMP 83610-01-000, SCREW G39-08-12U
- 5 CLAMP 10497-03-000, SCREW G39-08-12U
- 4 USE TIE-WIRE 8343-04-000 TO SECURE WIRES TO FLOOR SUPPORT FRAME AT LEAST ONCE EVERY 600MM.
- 3 SECURE CORD AWAY FROM ALL MOVING PARTS AND EXHAUST WITH WIRE-TIE 93147-01-000 AS REQUIRED
- 2 SEE WIRING INSTL-FRONT END FOR ADDITIONAL INFORMATION.
- 1 SEE WIRING INSTL-BODY, 110V FOR ADDITIONAL INFORMATION.

NOTES:

- 38M TIRE MONITORING SYSTEM
- 282 SOLAR PANEL - 100 WATT
- 265 CODES/STANDARDS-CSA/CMVSS
- 1B1 CODES/STANDARDS USA

WINNEBAGO COPYRIGHT 2016 WINNEBAGO INDUSTRIES, INC.	
DSNR:	ALL DIMENSIONS ARE IN MILLIMETERS
DFFR:	
UNSPECIFIED TOLERANCES:	MATERIAL:
WHOLE DIM (X) : 3	
ONE-PLACE (X.X) : 1.5	
TWO-PLACE (X.XX) : 0.50	
ANGLE : 1°	
REFER TO ES0018 FOR FASTENER TIGHTENING GUIDELINES	WEIGHT: (LBS) FIRST USED:
	18 P40A
DESCRIPTION: WIRING INSTL-CHASSIS	
SHEET: 1 OF 8	ITEM/PART NO: 000026346 / 31559501000
REF:	REV:
	1 06-Sep-2018

FOR ELECTRICAL TORQUE SPECIFICATIONS SEE DWG NO. 128783-01-000

FOR ELECTRICAL CALLOUTS SEE DWG NO. 121339-01-000

DETAIL AA 3

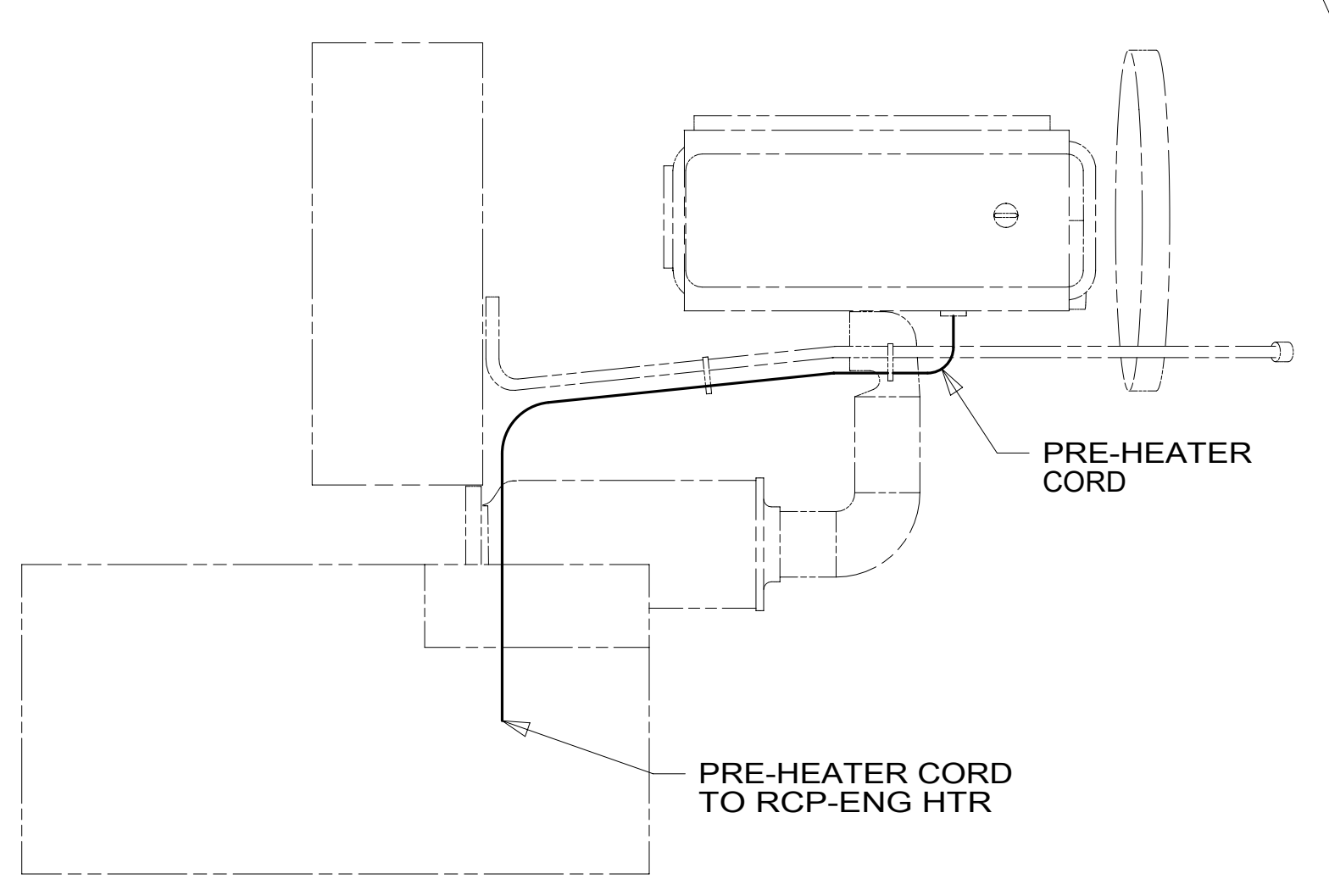

DETAIL AA 3

8 7 6 5 4 3 2 1



D

D

CABLE ASM (YEL) FROM COACH BATTERY FUSE TO COACH STUD,JUMP START	175207-52-069	
CABLE ASM (YEL) FROM STUD,JUMP START TO COACH SIDE OF AUX START SOLENOID	175207-52-004	
CABLE ASM (BLK) FROM STUD,JUMP START "GROUND" TO FRAME RAIL GROUND	175211-01-010	
CABLE ASM (ORG) FROM COACH BATTERY TO INVERTER FUSE	175207-66-010	
CABLE ASM (ORG) FROM INVERTER FUSE TO INVERTER DISCONNECT SWITCH	175207-67-052	2
CABLE ASM (ORG) FROM INVERTER DISCONNECT TO POSITIVE TERMINAL ON INVERTER	175207-65-005	
CABLE ASM (BLK) FROM BATTERY TO INVERTER NEGATIVE TERMINAL	175211-01-054	2
CABLE ASM (BLK) FROM COACH BATTERY TO FRAME RAIL GROUND	175211-02-072	
CABLE ASM (PUR) FROM CHASSIS BATTERY DISCONNECT TO CHASSIS ISOLATED STUD	175207-15-005	
CABLE ASM (BLU) FROM CHASSIS DISCONNECT FUSE TO LEVELING SYSTEM PUMP	141416-26-120	1
CABLE ASM (BLK) FROM LEVELING SYSTEM TO FRAME RAIL GROUND	133567-11-005	1
CABLE ASM (GRN) FROM COACH BAT DISC RELAY TO PASS THRU STUD IN FRONT LEFT COMPT	175207-42-125	2
CABLE ASM (GRN) FROM PASS THRU STUD IN FRONT LEFT COMPT TO GENERATOR	175207-42-031	3
CABLE ASM (BLK) FROM GENERATOR TO FRAME RAIL GROUND BOLT	175211-02-020	2
CABLE ASM (YEL) JUMPER BETWEEN POSITIVE POSTS ON COACH BATTERY	141417-52-004 141417-51-002 (4)	
CABLE ASM (BLK) JUMPER BETWEEN NEGATIVE POSTS ON COACH BATTERY	133568-12-004 133568-11-002 (4)	
CABLE ASM (RED) JUMPER BETWEEN POSITIVE POSTS IN LEFT FRONT COMPT	141417-32-002	
CABLE ASM-TEMPERATURE,BATTERY	175385-03-000	
CABLE ASM (RED) FROM CHASSIS BATTERY FUSE TO CHASSIS SIDE OF AUX START SOLENOID	175207-35-008	3
CABLE ASM (RED) FROM CHASSIS BATTERY TO CHASSIS BATTERY FUSE	175207-35-005	2
CABLE ASM (YEL) FROM COACH BATTERY TO COACH BATTERY FUSE	175207-52-006	2
CABLE ASM (YEL) FROM COACH DISCONNECT TO MULTIPLEX PANEL	189044-01-072	2
CABLE ASM (YEL) FROM MULTIPLEX PANEL TO MULTIPLEX PANEL	189044-01-044	

2

2

1

1

2

3

2

3

2

2

2

C

C

B

B

A

A

- 3 SEE WIRING INSTL-FRONT END FOR ADDITIONAL INFORMATION.
- 2 SEE WIRING INSTL-CHASSIS FOR ADDITIONAL INFORMATION.
- 1 SEE LEVELING SYSTEM INSTL FOR ADDITIONAL INFORMATION.

NOTES:

265 CODES/STANDARDS-CSA/CMVSS
1B1 CODES/STANDARDS USA

FOR ELECTRICAL TORQUE SPECIFICATIONS SEE DWG NO. 128783-01-000

FOR ELECTRICAL CALLOUTS SEE DWG NO. 121339-01-000

DESCRIPTION:	1B1 265	
WIRING INSTL-CHASSIS		
SHEET:	ITEM/PART NO:	REV
2 OF 8	000026346 / 31559501000	

8 7 6 5 4 3 2 1 06-Sep-2018



8 7 6 5 4 3 2 1

D
C
B
A

BATTERY-12V
174923-01-000 (6)
BOLT
51387-06-000 (8)
NUT-HEX
D39-05-00U (8)
WASHER-RUBBER
184541-01-CHT (8)
STRAP-BATTERY
TIE DOWN
138914-01-CHT (6)

CABLE ASM (ORG)
TO INVERTER FUSE

TO GROUND STUD
BEHIND CHASSIS
BATTERIES

CABLE ASM (YEL)

CABLE ASM (BLK)
TO INVERTER

CABLE ASM-
TEMPERATURE,BATTERY

HOLDER-FUSE
115187-02-000
FUSE-400 AMP
115187-05-000
SCREW
G39-10-16U (2)

CABLE ASM (YEL)
COACH BATTERY JUMPER

CABLE ASM (BLK)
COACH BATTERY JUMPER

TRAY ASM-BATTERY
176166-01-CHT (2)
NUT
D39-06-00U (6)
WASHER
E13-17-00U (6)

282 CONNECT SOLAR PANEL
GROUND HERE
CIRCUIT ZZD
29W TAPE CIRCUIT ZZD
BACK TO HARNESS

HOLDER-FUSE
188460-01-000
FUSE-500 AMP
188461-04-000
SCREW
G39-10-12U (2)

VIEW CA

FOR ELECTRICAL
TORQUE
SPECIFICATIONS
SEE DWG NO.
128783-01-000

FOR
ELECTRICAL
CALLOUTS
SEE DWG NO.
121339-01-000

- 29W SOLAR PANEL/BATTERY CHRG W/O
- 282 SOLAR PANEL - 100 WATT
- 265 CODES/STANDARDS-CSA/CMVSS
- 1B1 CODES/STANDARDS USA

DESCRIPTION:		1B1 265	
WIRING INSTL-CHASSIS			
SHEET:	ITEM/PART NO.:	REV	
3 OF 8	000026346 / 31559501000		

8 7 6 5 4 3 2 1 06-Sep-2018

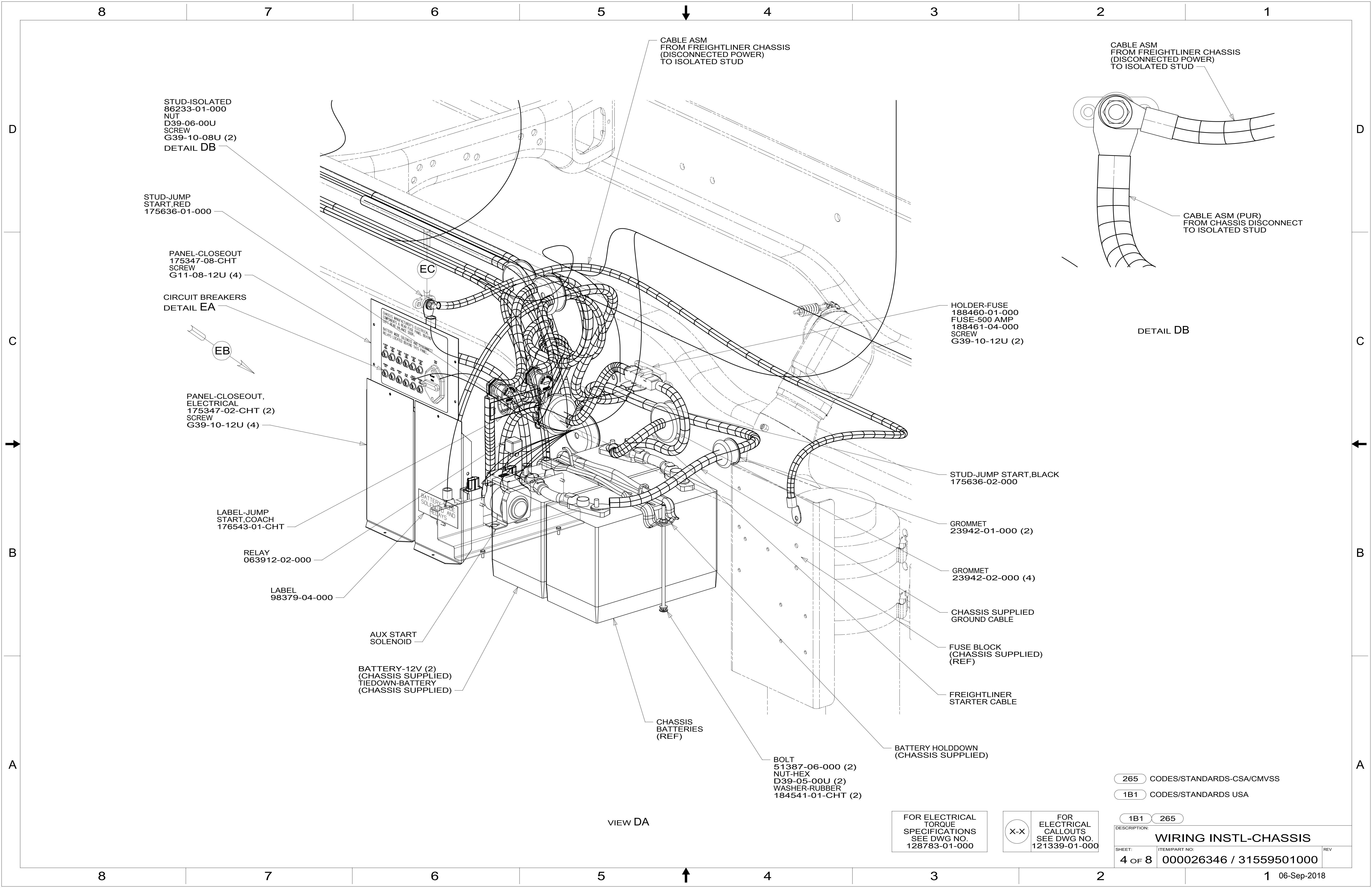

STUD-ISOLATED
86233-01-000
NUT
D39-06-00U
SCREW
G39-10-08U (2)
DETAIL DB

STUD-JUMP
START,RED
175636-01-000

PANEL-CLOSEOUT
175347-08-CHT
SCREW
G11-08-12U (4)

CIRCUIT BREAKERS
DETAIL EA

EB

PANEL-CLOSEOUT,
ELECTRICAL
175347-02-CHT (2)
SCREW
G39-10-12U (4)

LABEL-JUMP
START,COACH
176543-01-CHT

RELAY
063912-02-000

LABEL
98379-04-000

AUX START
SOLENOID

BATTERY-12V (2)
(CHASSIS SUPPLIED)
TIEDOWN-BATTERY
(CHASSIS SUPPLIED)

CHASSIS
BATTERIES
(REF)

BOLT
51387-06-000 (2)
NUT-HEX
D39-05-00U (2)
WASHER-RUBBER
184541-01-CHT (2)

VIEW DA

CABLE ASM
FROM FREIGHTLINER CHASSIS
(DISCONNECTED POWER)
TO ISOLATED STUD

CABLE ASM
FROM FREIGHTLINER CHASSIS
(DISCONNECTED POWER)
TO ISOLATED STUD

CABLE ASM (PUR)
FROM CHASSIS DISCONNECT
TO ISOLATED STUD

HOLDER-FUSE
188460-01-000
FUSE-500 AMP
188461-04-000
SCREW
G39-10-12U (2)

DETAIL DB

STUD-JUMP START,BLACK
175636-02-000

GROMMET
23942-01-000 (2)

GROMMET
23942-02-000 (4)

CHASSIS SUPPLIED
GROUND CABLE

FUSE BLOCK
(CHASSIS SUPPLIED)
(REF)

FREIGHTLINER
STARTER CABLE

BATTERY HOLDDOWN
(CHASSIS SUPPLIED)

FOR ELECTRICAL
TORQUE
SPECIFICATIONS
SEE DWG NO.
128783-01-000

FOR
ELECTRICAL
CALLOUTS
SEE DWG NO.
121339-01-000

265 CODES/STANDARDS-CSA/CMVSS

1B1 CODES/STANDARDS USA

1B1 265

DESCRIPTION: WIRING INSTL-CHASSIS		
SHEET: 4 OF 8	ITEM/PART NO: 000026346 / 31559501000	REV
		1 06-Sep-2018

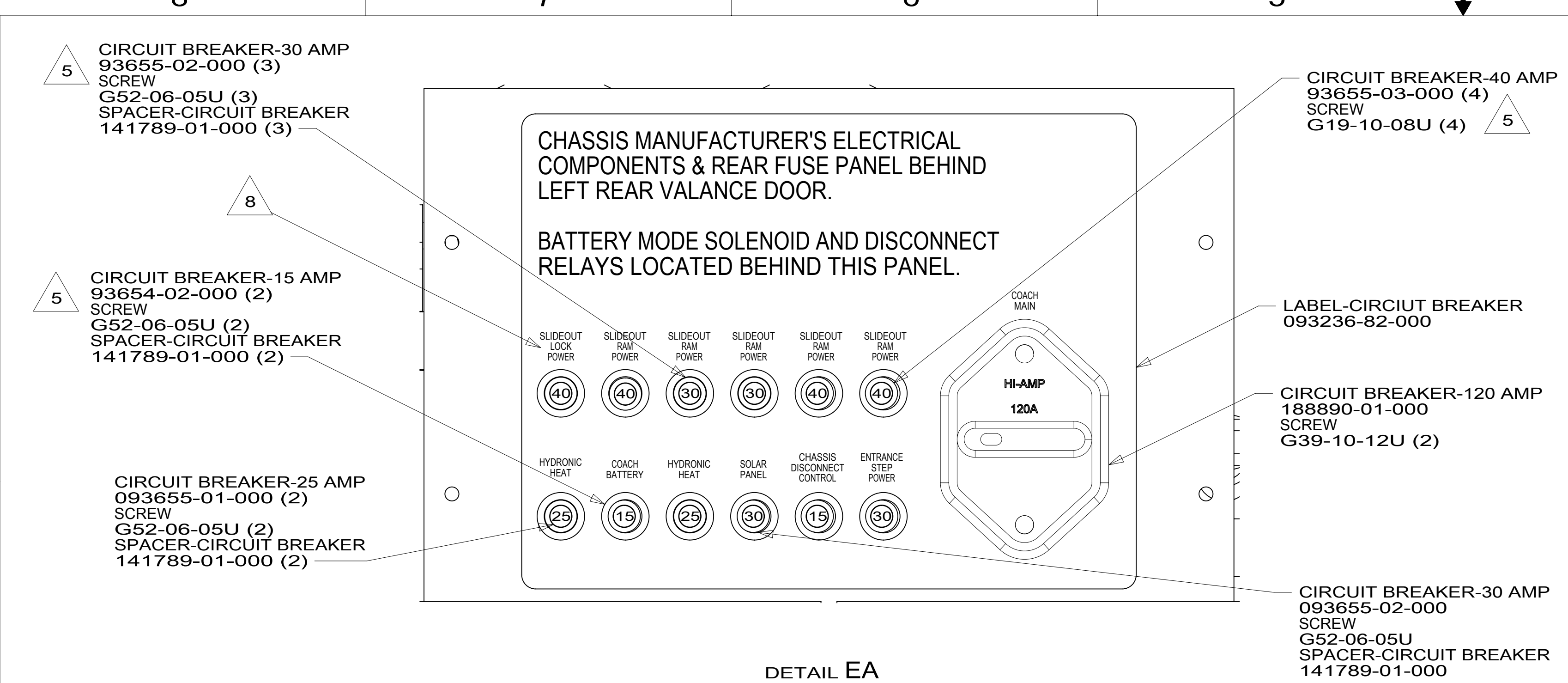

DETAIL EA

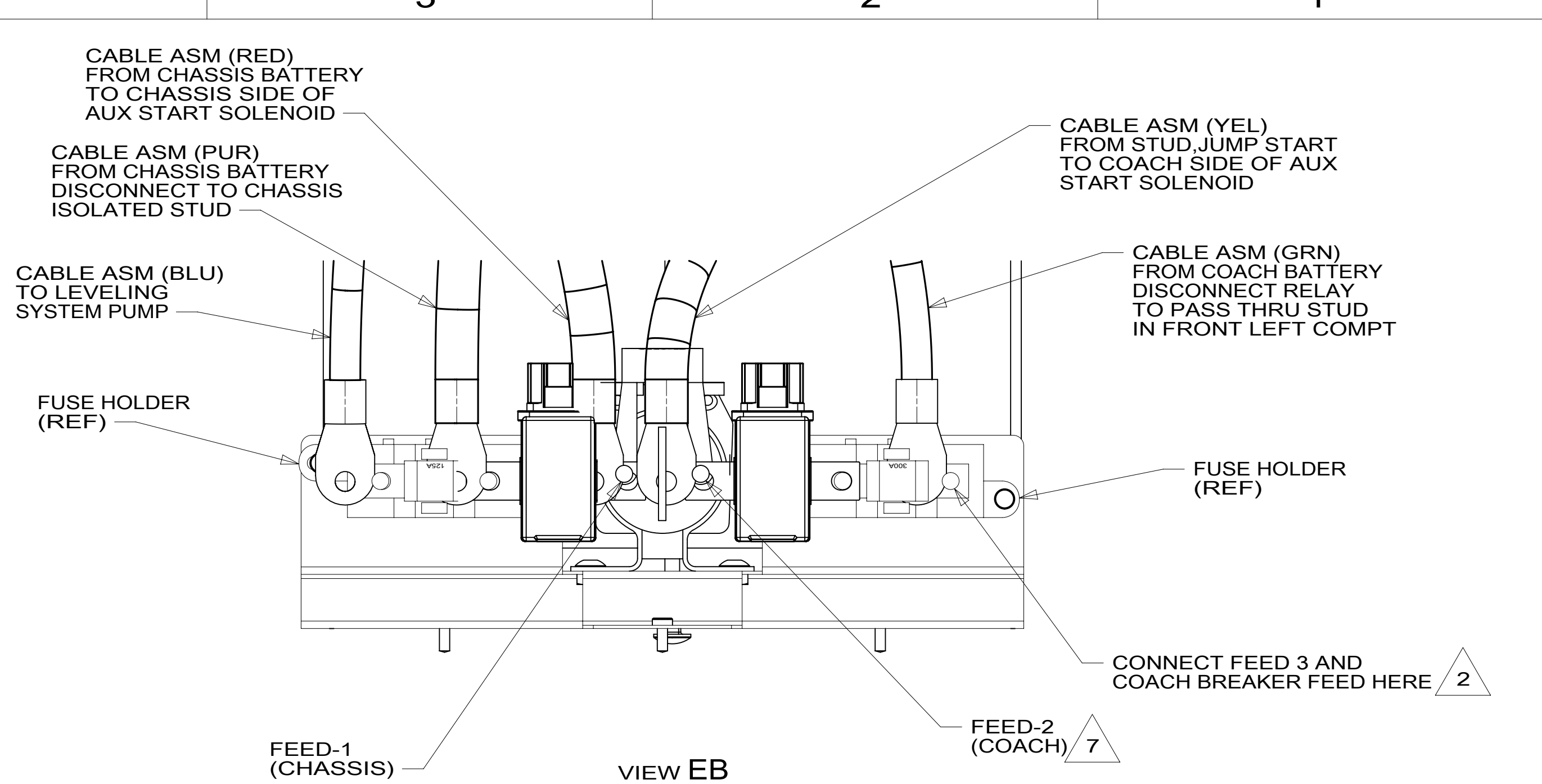

VIEW EB

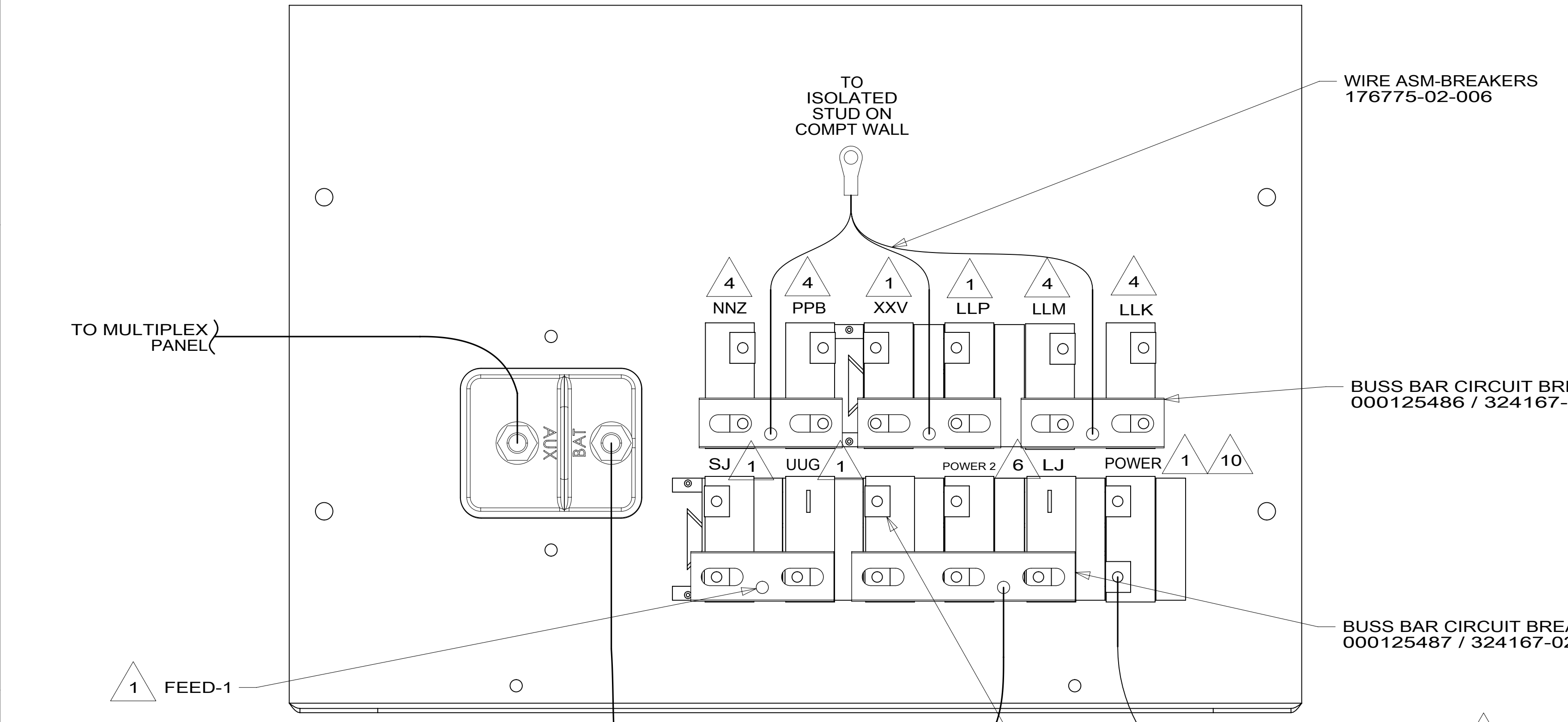

DETAIL EA (BACK VIEW-COMPONENTS)

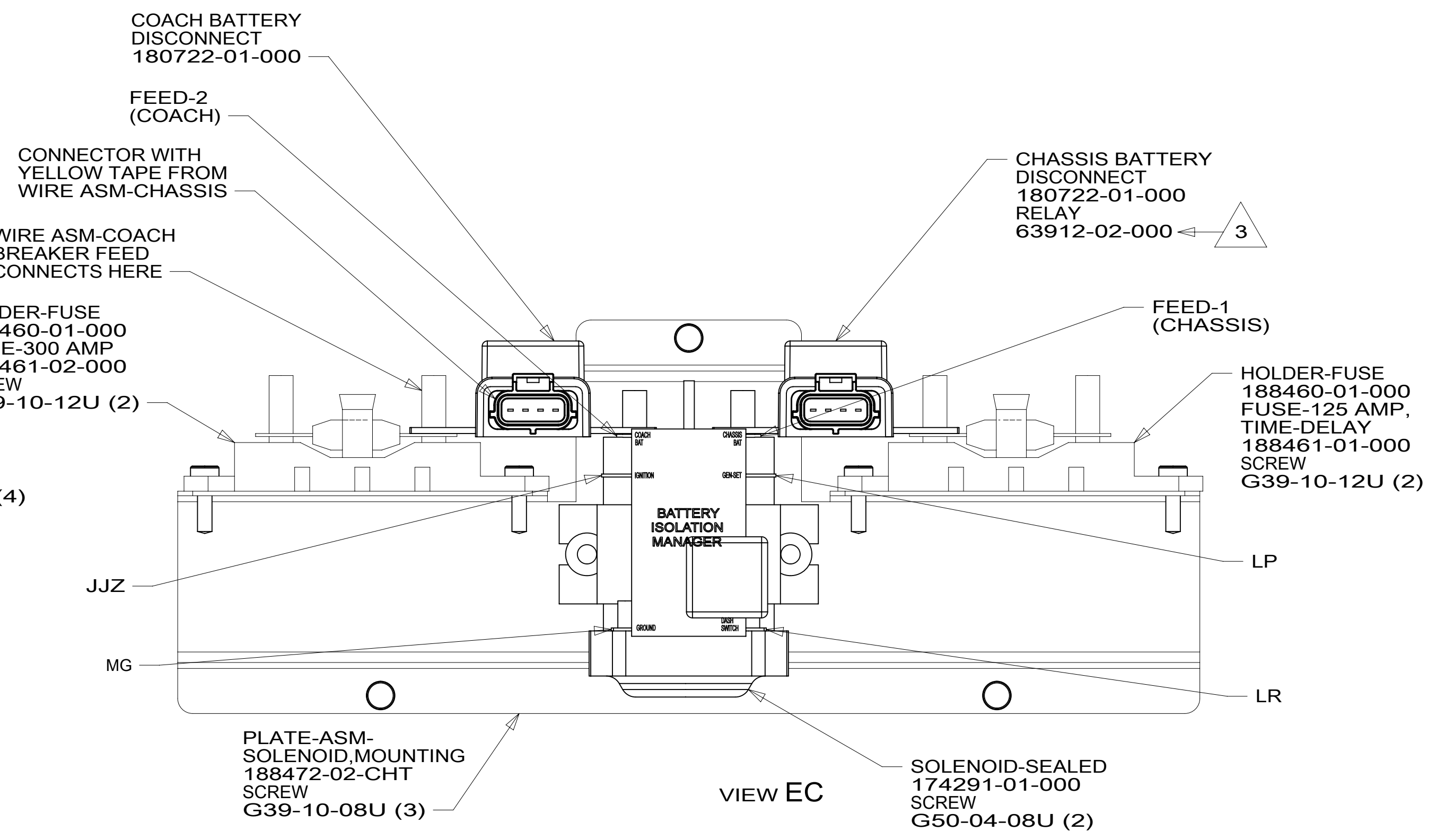

VIEW EC

- NOTES:
- 7 FROM WIRE ASM-CHASSIS MARKED WITH YEL TAPE.
 - 6 FROM WIRE ASM-CHASSIS MARKED WITH BLU TAPE.
 - 5 REPLACE EXISTING SCREW TO PROPERLY ATTACH BREAKER TO BUSS BAR.
 - 4 FROM WIRE ASM-SLIDEOUT POWER.
 - 3 RELAY CONNECTS TO WIRE ASM-CHASSIS. (CHASSIS DISCONNECT LOCKOUT RELAY)
 - 2 WIRE TO BE MARKED BY WRAP OF GRN TAPE 19 MM WIDE WITHIN 50 MM OF END.
 - 1 CIRCUITS BRANCH FROM WIRE ASM-CHASSIS.

- 10 WIRE TO BE MARKED BY WRAP OF BRN TAPE 19 MM WIDE WITHIN 50 MM OF END.
- 9 WIRE TO BE MARKED BY WRAP OF WHT TAPE 19 MM WIDE WITHIN 50 MM OF END.
- 8 BLACKEN OUT THE WORD "LOCK" WITH A BLACK MARKER.

FOR ELECTRICAL TORQUE SPECIFICATIONS SEE DWG NO. 128783-01-000

FOR ELECTRICAL CALLOUTS SEE DWG NO. 121339-01-000

265 CODES/STANDARDS-CSA/CMVSS
1B1 CODES/STANDARDS USA

DESCRIPTION:		1B1 265	
WIRING INSTL-CHASSIS			
SHEET:	ITEM/PART NO:	REV	
5 OF 8	000026346 / 31559501000		

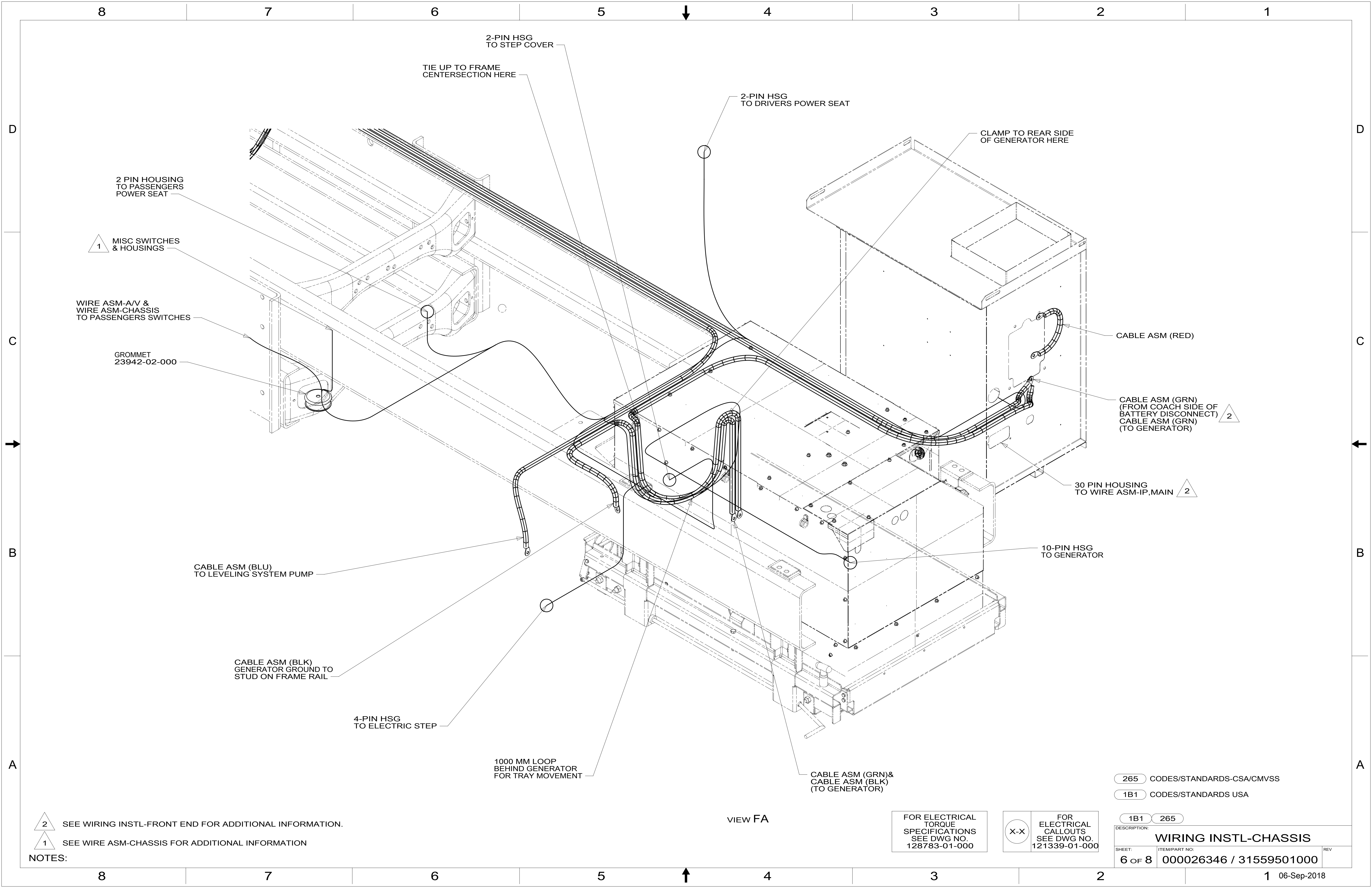

8 7 6 5 4 3 2 1

D
C
B
A

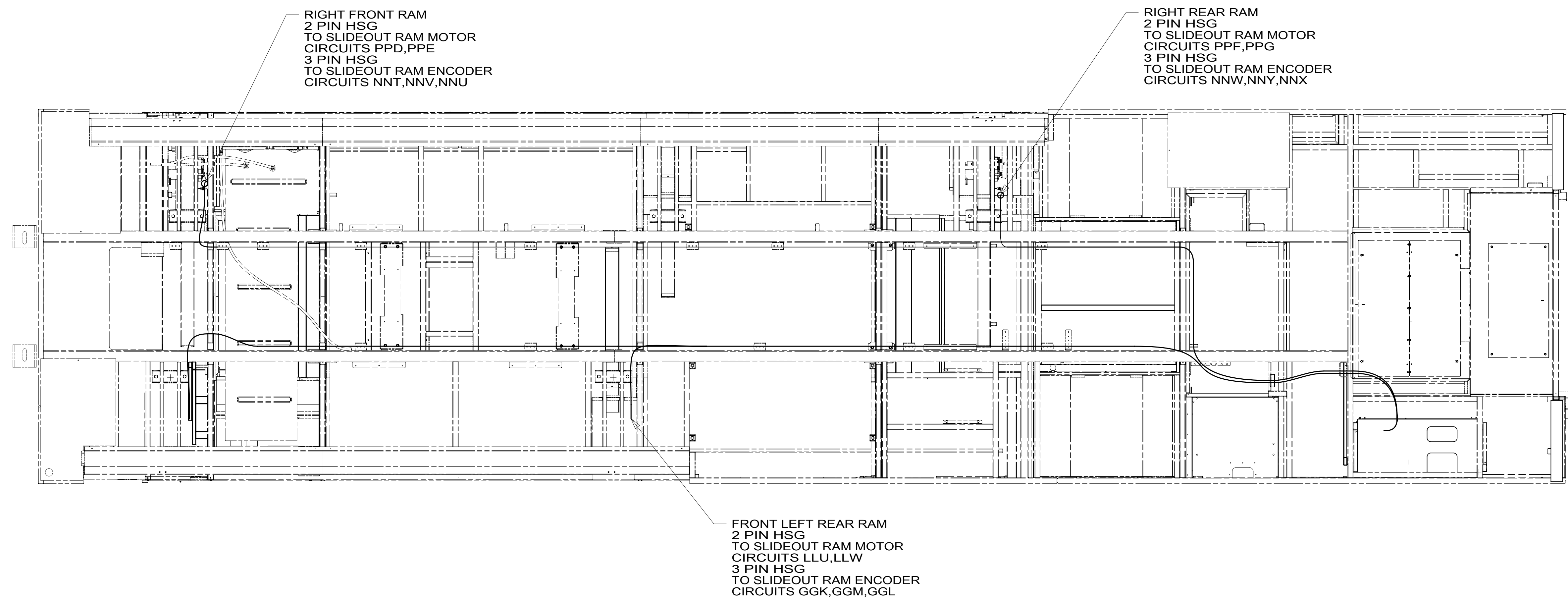

RIGHT FRONT RAM
 2 PIN HSG
 TO SLIDEOUT RAM MOTOR
 CIRCUITS PPD,PPE
 3 PIN HSG
 TO SLIDEOUT RAM ENCODER
 CIRCUITS NNT,NNV,NNU

RIGHT REAR RAM
 2 PIN HSG
 TO SLIDEOUT RAM MOTOR
 CIRCUITS PPF,PPG
 3 PIN HSG
 TO SLIDEOUT RAM ENCODER
 CIRCUITS NNW,NNY,NNX

FRONT LEFT REAR RAM
 2 PIN HSG
 TO SLIDEOUT RAM MOTOR
 CIRCUITS LLU,LLW
 3 PIN HSG
 TO SLIDEOUT RAM ENCODER
 CIRCUITS GGK,GGM,GGL

1. AT MINIMUM ALL WIRES TO BE SUPPORTED AND SECURED PER CODE REQUIREMENTS. USE CLAMP 10495 OR 10497 OR WIRE TIE 8343 OR 108046 AND SCREW G67-XX-XXX OR G56-XX-XXX AS APPROPRIATE FOR INSTALLATION.

NOTES:

FOR ELECTRICAL TORQUE SPECIFICATIONS SEE DWG NO. 128783-01-000

FOR ELECTRICAL CALLOUTS SEE DWG NO. 121339-01-000

265 CODES/STANDARDS-CSA/CMVSS
 1B1 CODES/STANDARDS USA

1B1 265	
DESCRIPTION: WIRING INSTL-CHASSIS	
SHEET: 7 OF 8	ITEM/PART NO: 000026346 / 31559501000
REV	

8 7 6 5 4 3 2 1 06-Sep-2018

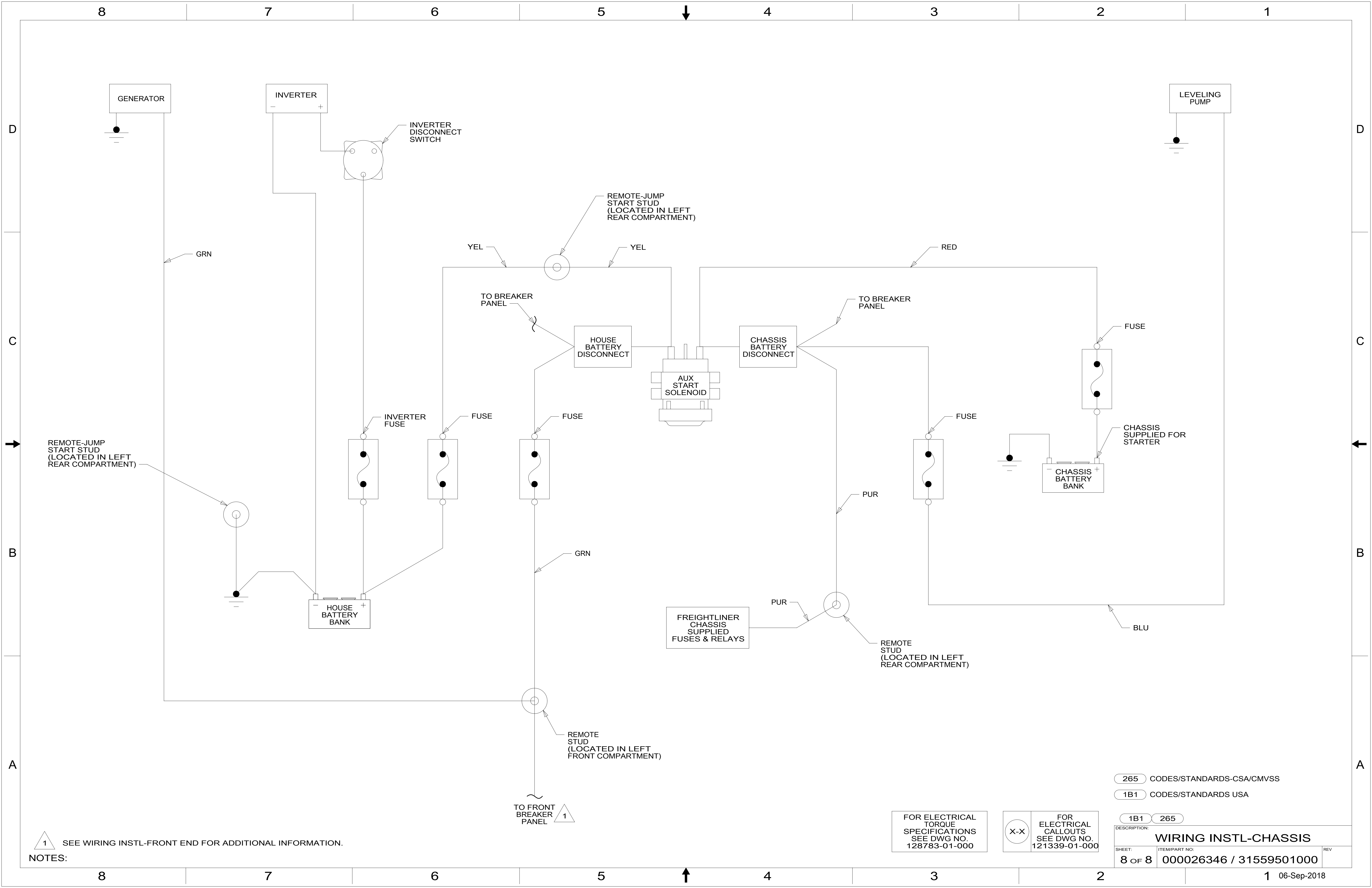

1 SEE WIRING INSTL-FRONT END FOR ADDITIONAL INFORMATION.

FOR ELECTRICAL TORQUE SPECIFICATIONS SEE DWG NO. 128783-01-000

FOR ELECTRICAL CALLOUTS SEE DWG NO. 121339-01-000

- 265 CODES/STANDARDS-CSA/CMVSS
- 1B1 CODES/STANDARDS USA

DESCRIPTION:		1B1 265	
WIRING INSTL-CHASSIS			
SHEET:	ITEM/PART NO.:	REV	
8 OF 8	000026346 / 31559501000		