

12 FOR INSTALLATION USE SILICON-ADHESIVE 131264-05-CHT. APPLY ON TOP OF PLATE, PLACE COVER ON, AND PUT ADHESIVE AROUND COVER.

11 VALVE MUST REMAIN OPEN AFTER WATER TEST.

10 INSTALL FAUCET W/OUT BASEPLATE.

9 ELBOW TO BE TURN 45° BELOW HORIZONTAL LINE.

8. ALL CRIMP FITTINGS TO 1/2" PEX TUBING REQUIRE 1/2" CLAMP 000156249 / 326670-01-000.

7. ALL CRIMP FITTINGS TO 5/8" PEX TUBING REQUIRE 5/8" CLAMP 000156248 / 326669-01-000.

6 LABEL HOT AND COLD SUPPLY TUBES AND TAPE FITTING TO TUBE BEFORE CABINET SET TO PREVENT MOVEMENT.

5 ADD PIPE WRAP (LADDER SCRAP 110157-02-000) INSULATION.

4 ADD TEFLON TAPE 010405-02-000.

3. ALL TUBING TO BE SECURED AT 1200 INTERVALS MAXIMUM WITH CLAMP 010495-01-000 AND SCREW 000G67-10-12U OR EQUIVALENT.

2. TUBING TO BE INSTALLED WITH SUFFICIENT SLOPE TO PROVIDE DRAINAGE TO NEAREST VALVE.

1. PLASTIC FITTINGS TO BE SEALED WITH SEALANT 084456-01-000.

NOTES:

- 53E WATER SYS WINTERIZATION PKG
- 53K WTR HTR-10GAL/ELECTRIC/LPGAS
- 1BU WTR HTR TKLS W/RECIRCUL PUMP
- 21S WASHER & DRYER-PAIR
- 21M WASHER/DRYER PREP

X-X
FOR WATER
CALLOUTS
SEE DWG NO.
000209446 /
303369-01-000

WINNEBAGO COPYRIGHT 2018 WINNEBAGO INDUSTRIES, INC.		ALL DIMENSIONS ARE IN MILLIMETERS	
UNSPECIFIED TOLERANCES:		MATERIAL:	
WHOLE DIM (X)	: 3		
ONE-PLACE (X.X)	: 1.5		
TWO-PLACE (X.XX)	: 0.50		
ANGLE	: 1°		
REFER TO ES0018 FOR FASTENER TIGHTENING GUIDELINES		WEIGHT: (LBS)	FIRST USED: (REF)
			17 L36G
DESCRIPTION: WATER SYSTEM INSTL			
SHEET:	ITEM/PART NO.:	REV	
1 OF 7	000016839 / 31325301000		
			REF: 1 29-Aug-2018

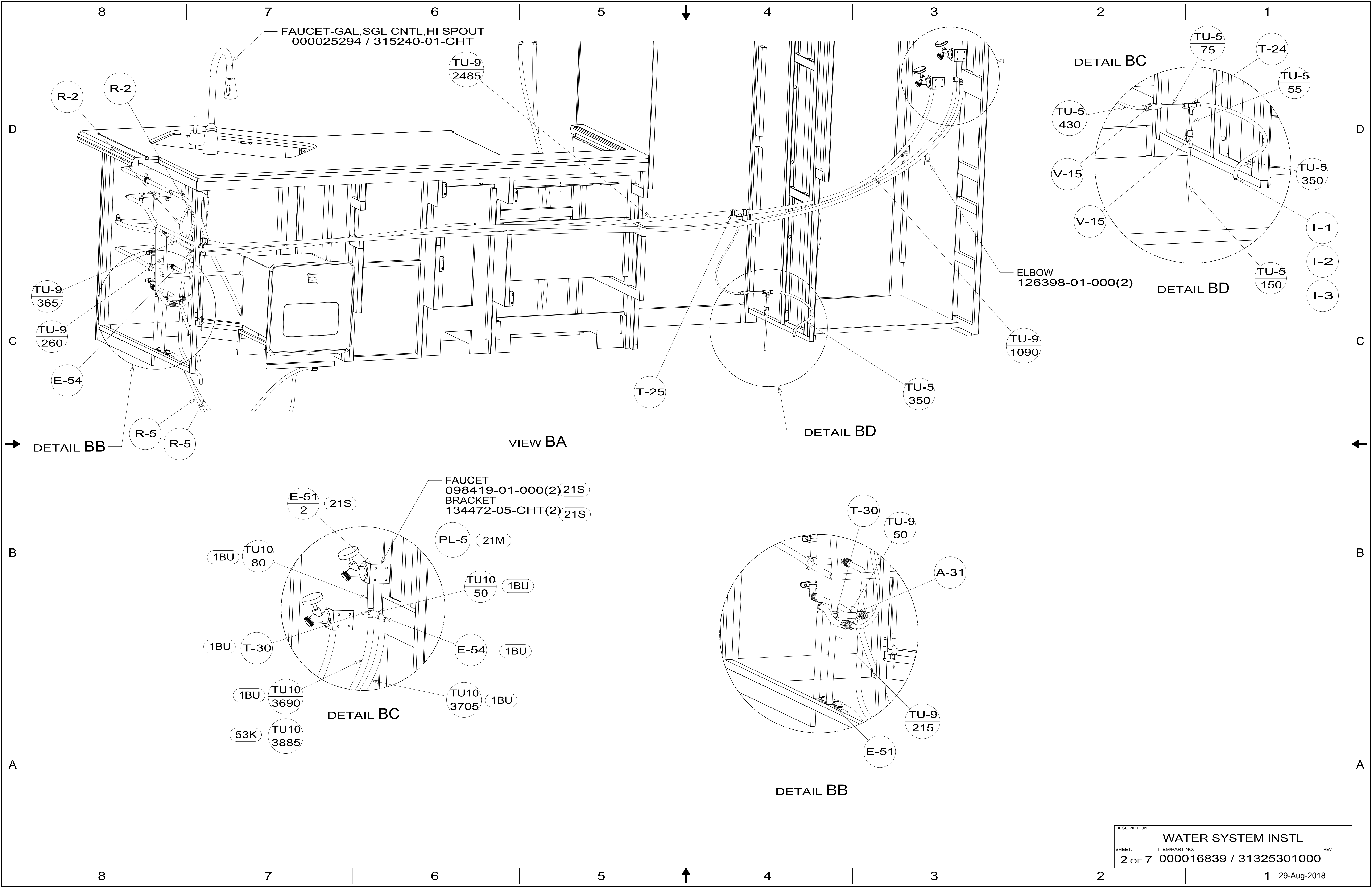

DESCRIPTION:		
WATER SYSTEM INSTL		
SHEET:	ITEM/PART NO:	REV
2 OF 7	000016839 / 31325301000	

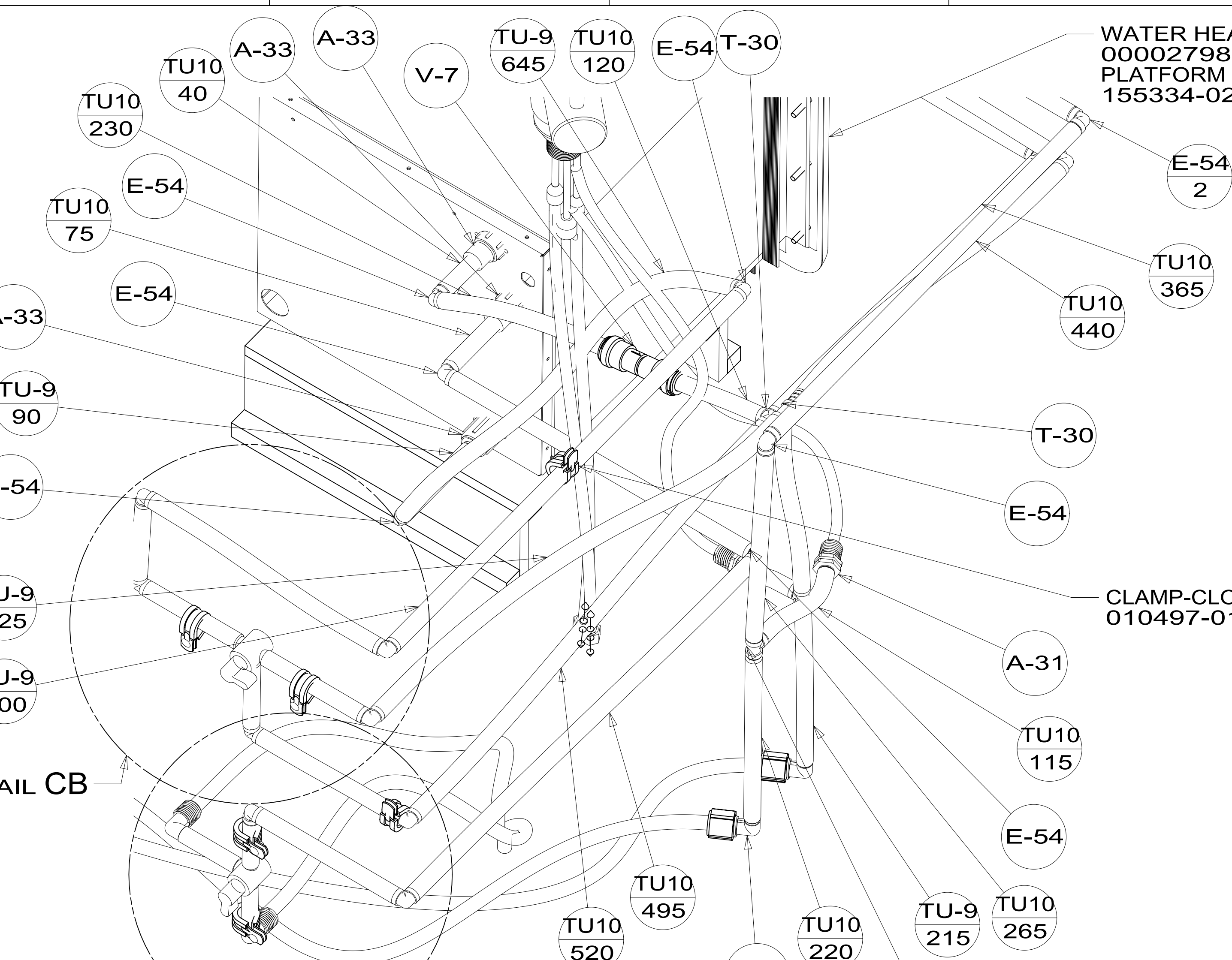
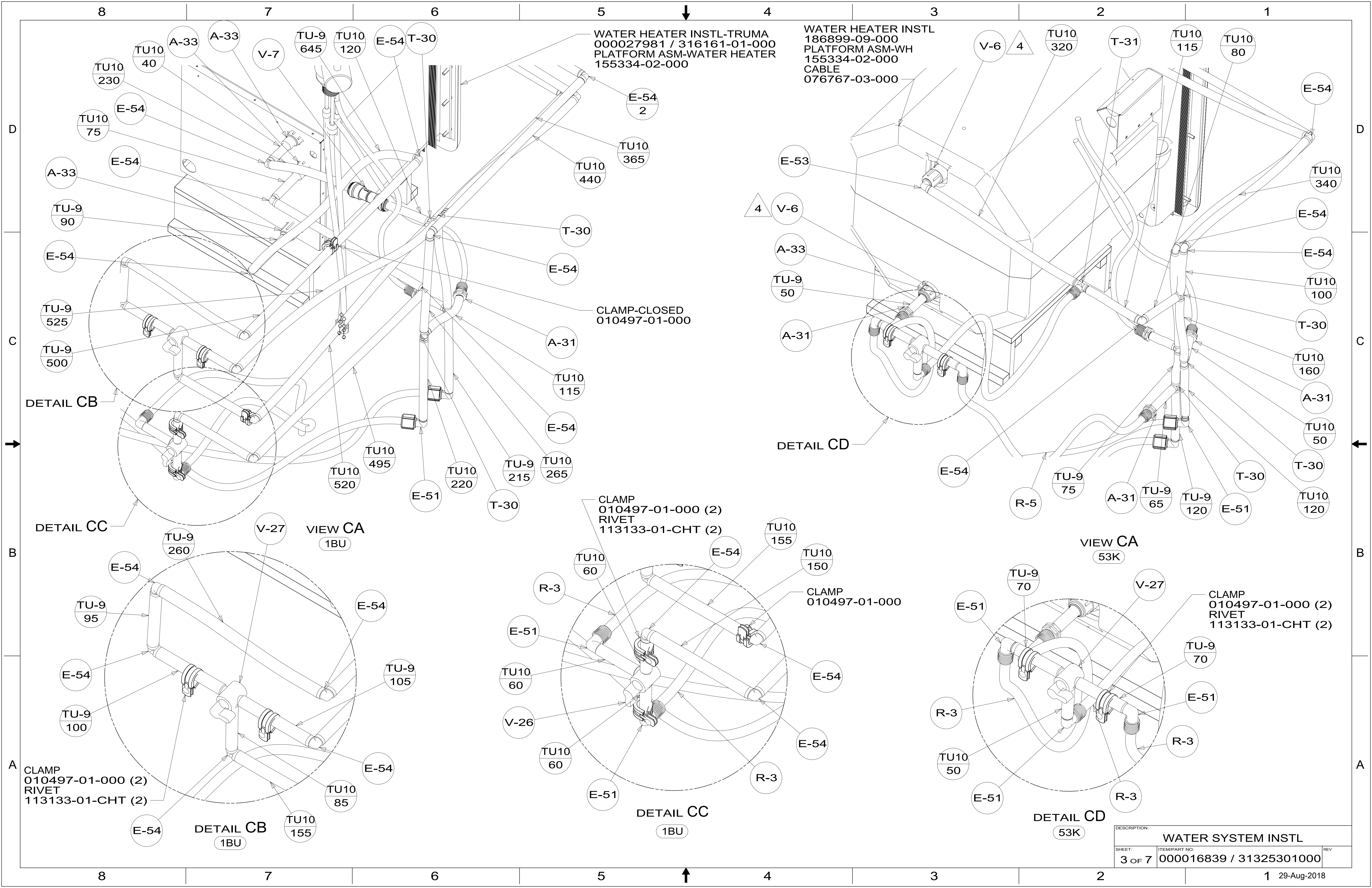

DETAIL CB

DETAIL CC

CLAMP
010497-01-000 (2)
RIVET
113133-01-CHT (2)

DETAIL CB
1BU

CLAMP-CLOSED
010497-01-000

CLAMP
010497-01-000 (2)
RIVET
113133-01-CHT (2)

DETAIL CC
1BU

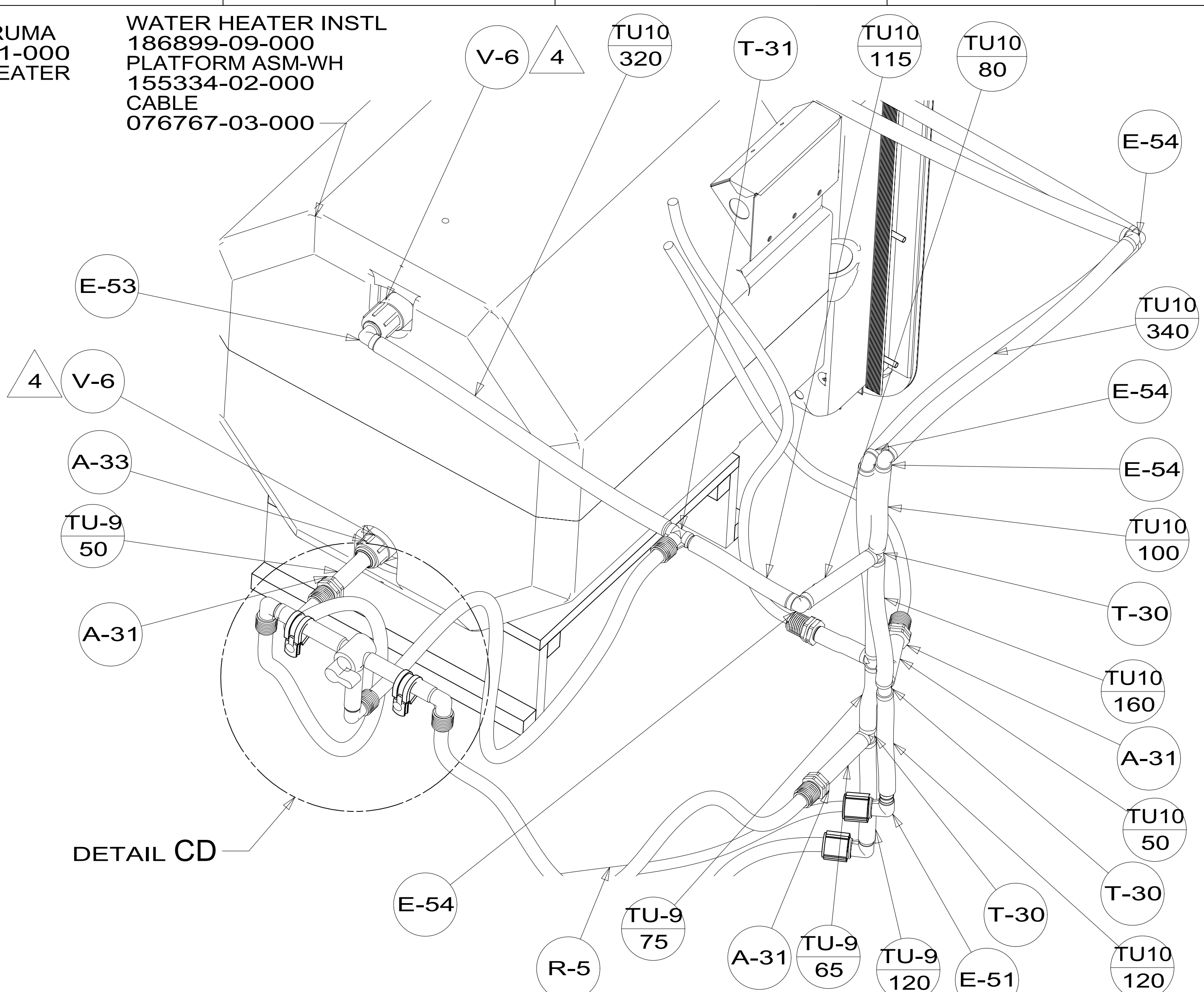

DETAIL CD

VIEW CA
53K

CLAMP
010497-01-000 (2)
RIVET
113133-01-CHT (2)

DETAIL CD
53K

DESCRIPTION:		
WATER SYSTEM INSTL		
SHEET:	ITEM/PART NO.:	REV
3 OF 7	000016839 / 31325301000	

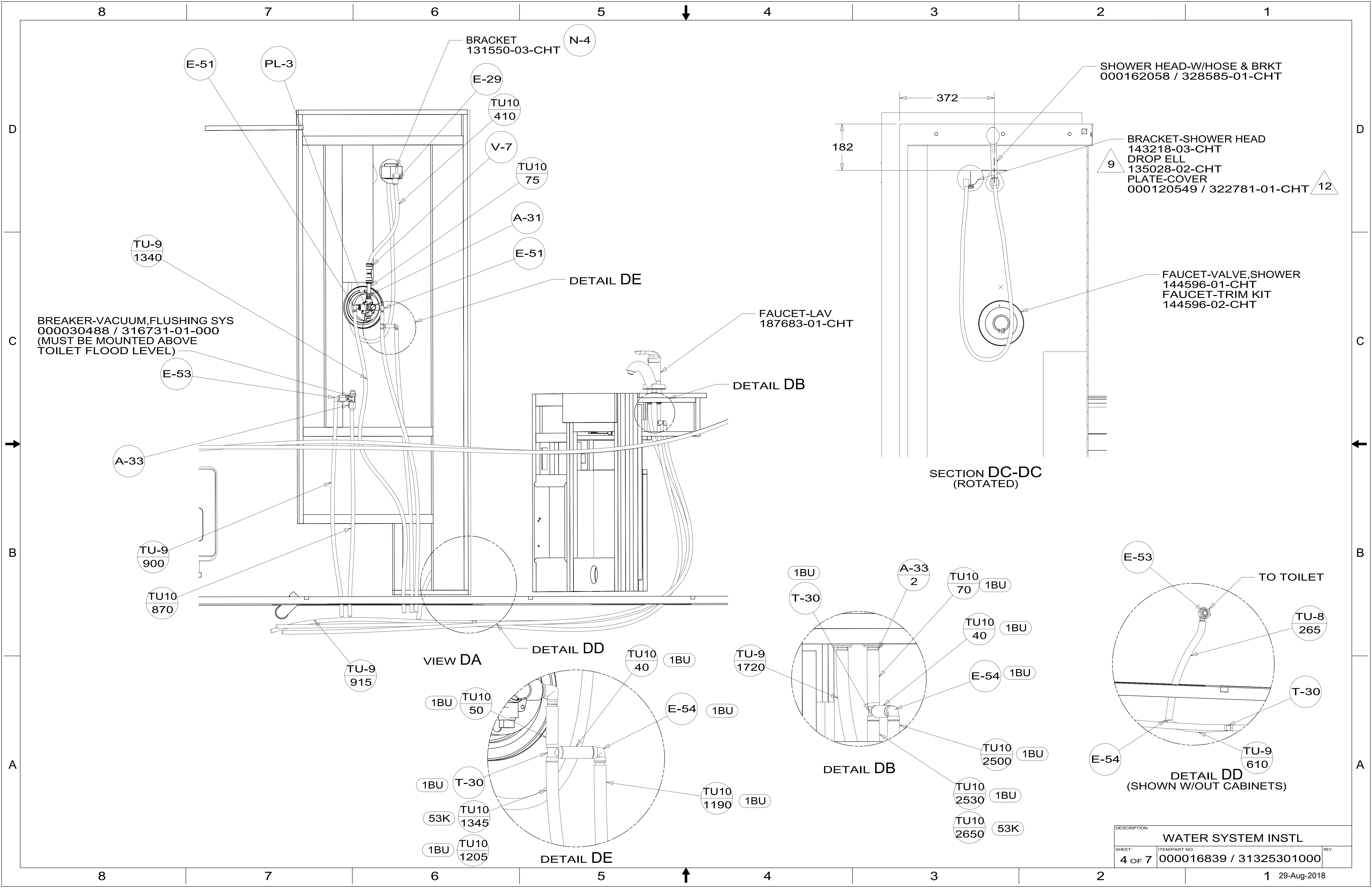

BREAKER-VACUUM, FLUSHING SYS
000030488 / 316731-01-000
(MUST BE MOUNTED ABOVE
TOILET FLOOD LEVEL)

372
182

SECTION DC-DC
(ROTATED)

SHOWER HEAD-W/HOSE & BRKT
000162058 / 328585-01-CHT

BRACKET-SHOWER HEAD
143218-03-CHT
DROP ELL
135028-02-CHT
PLATE-COVER
000120549 / 322781-01-CHT

FAUCET-VALVE, SHOWER
144596-01-CHT
FAUCET-TRIM KIT
144596-02-CHT

FAUCET-LAV
187683-01-CHT

TO TOILET

DETAIL DD
(SHOWN W/OUT CABINETS)

VIEW DA

DETAIL DB

DETAIL DE

DESCRIPTION: WATER SYSTEM INSTL		
SHEET: 4 OF 7	ITEM/PART NO: 000016839 / 31325301000	REV
		29-Aug-2018

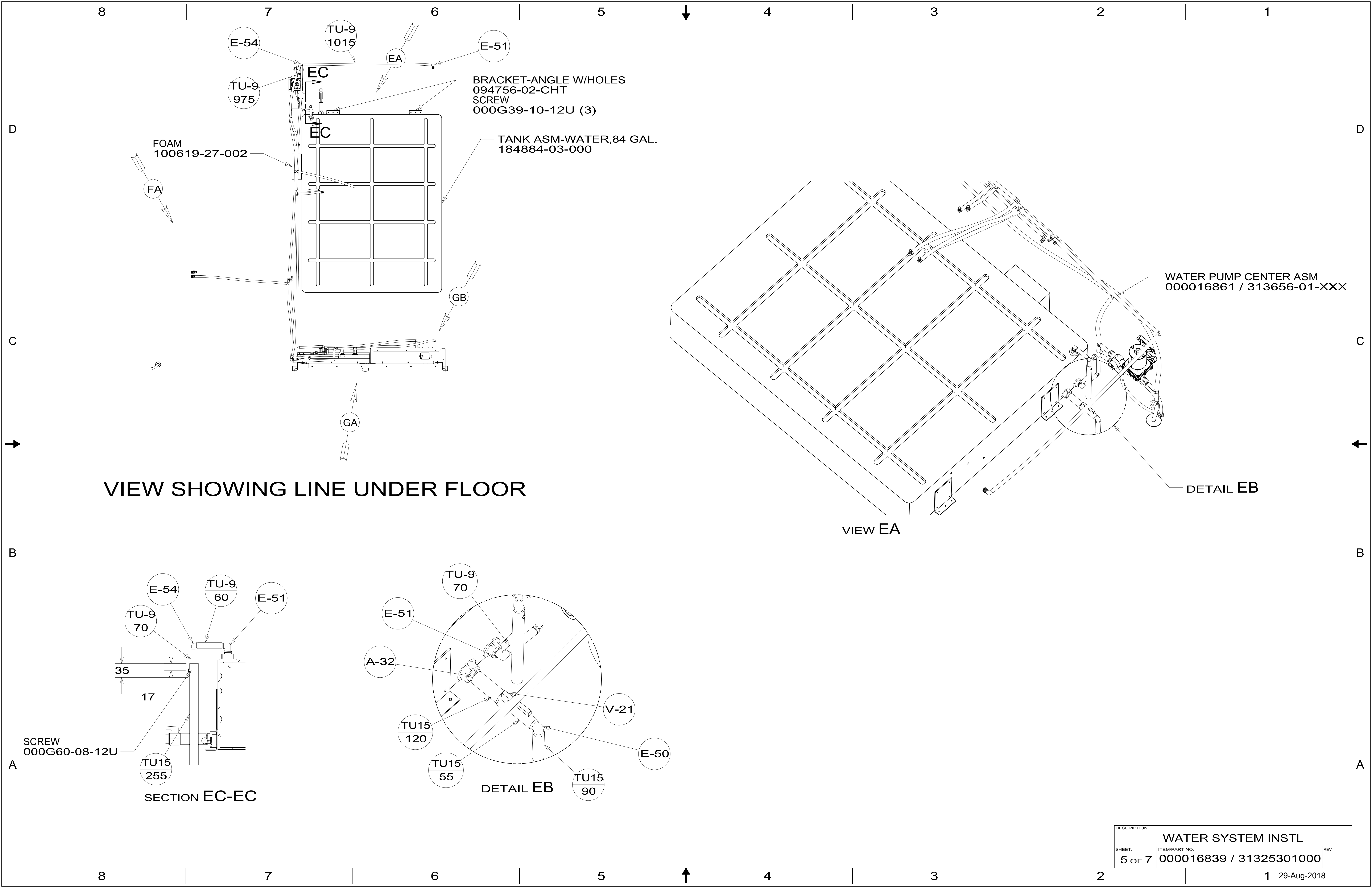

DESCRIPTION:		
WATER SYSTEM INSTL		
SHEET:	ITEM/PART NO:	REV
5 OF 7	000016839 / 31325301000	

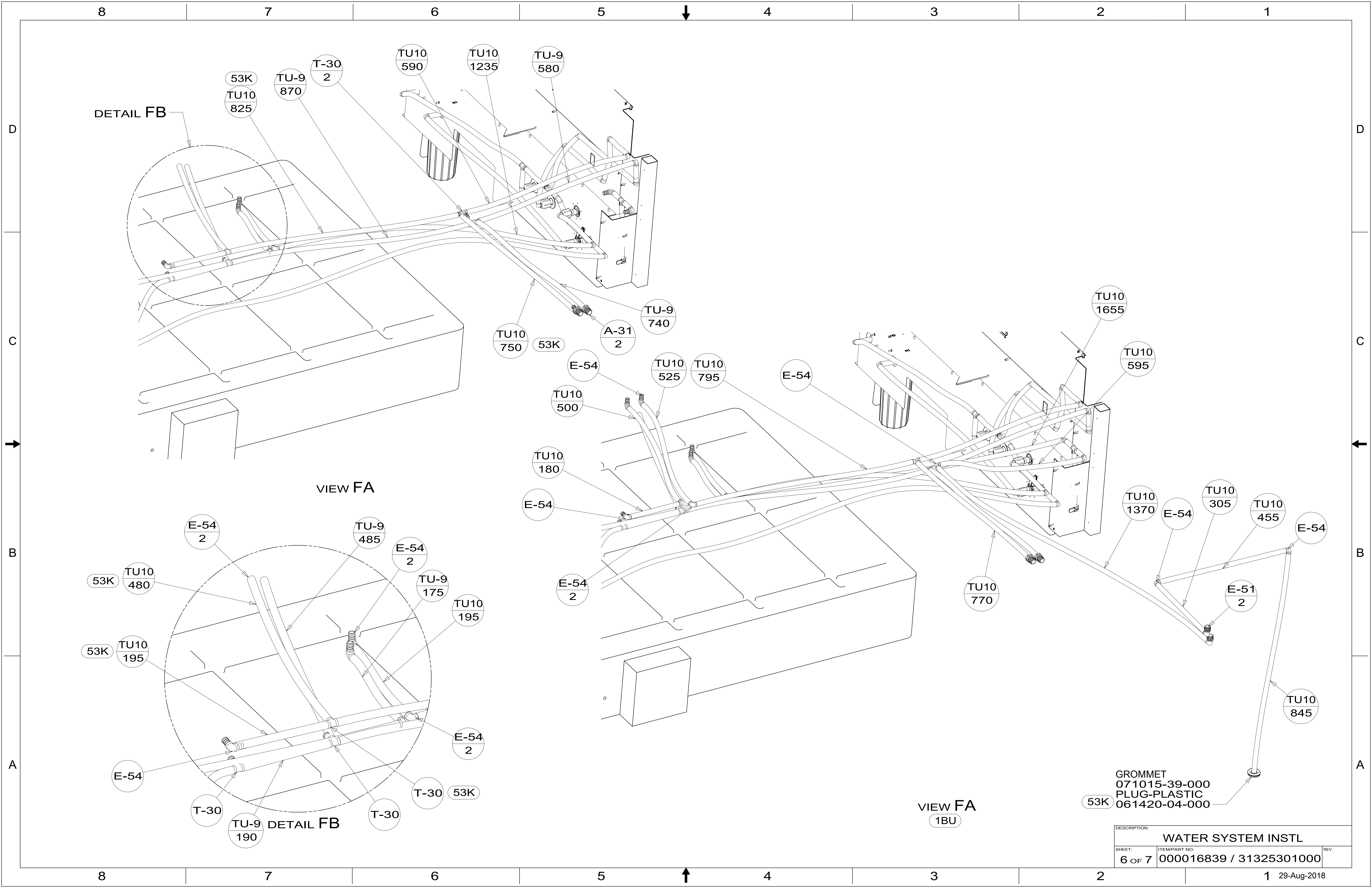

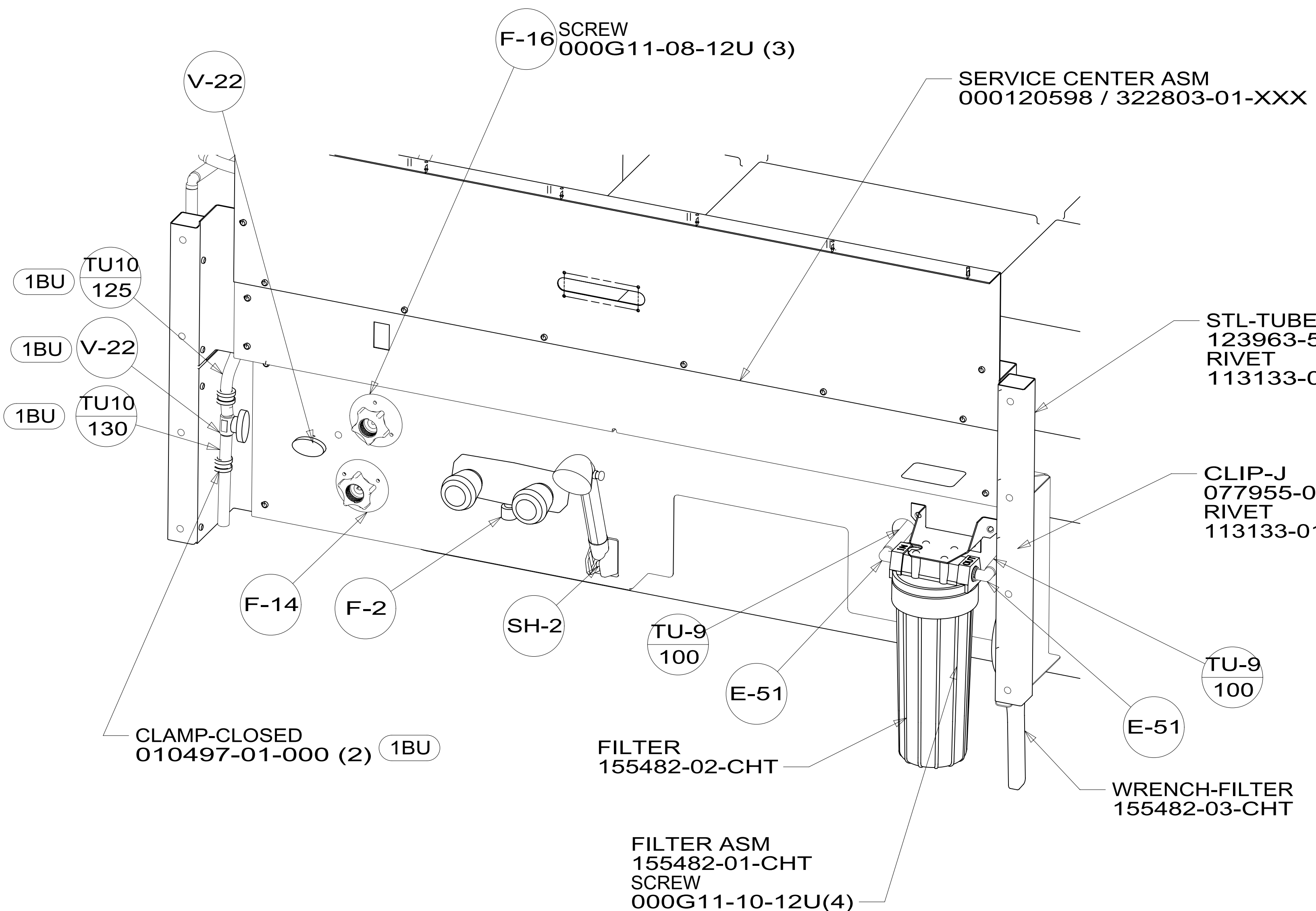
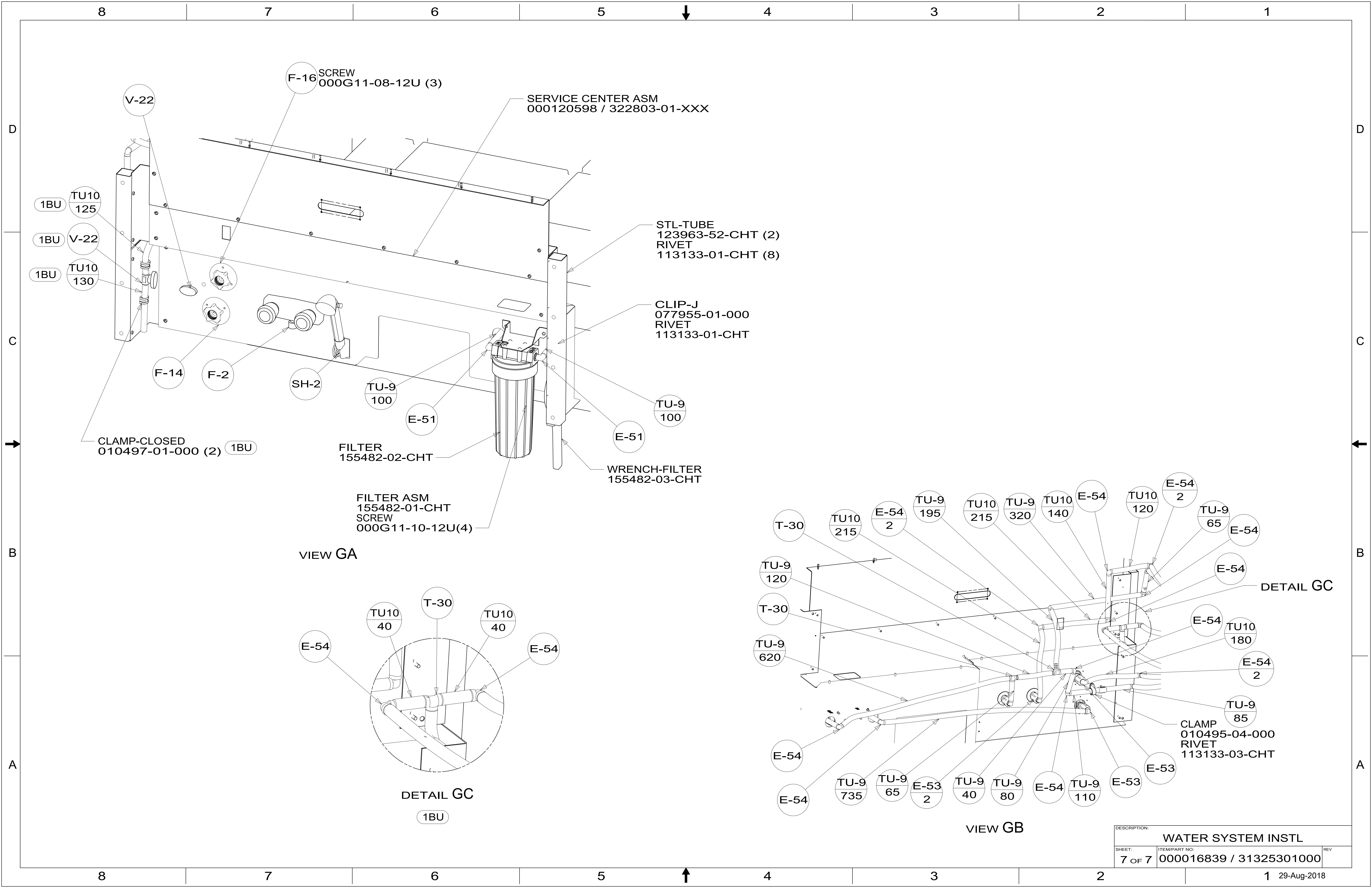

VIEW GA

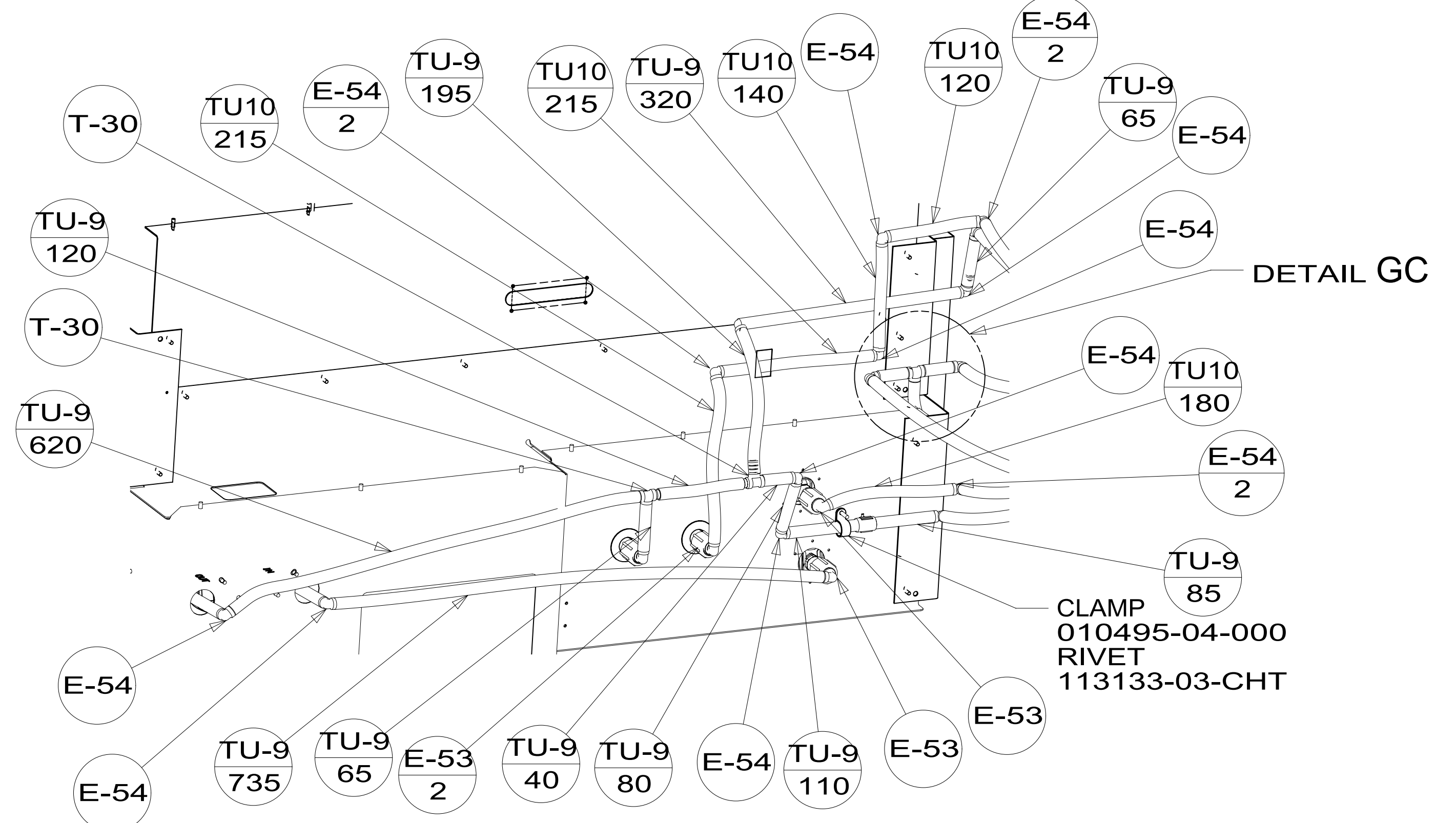
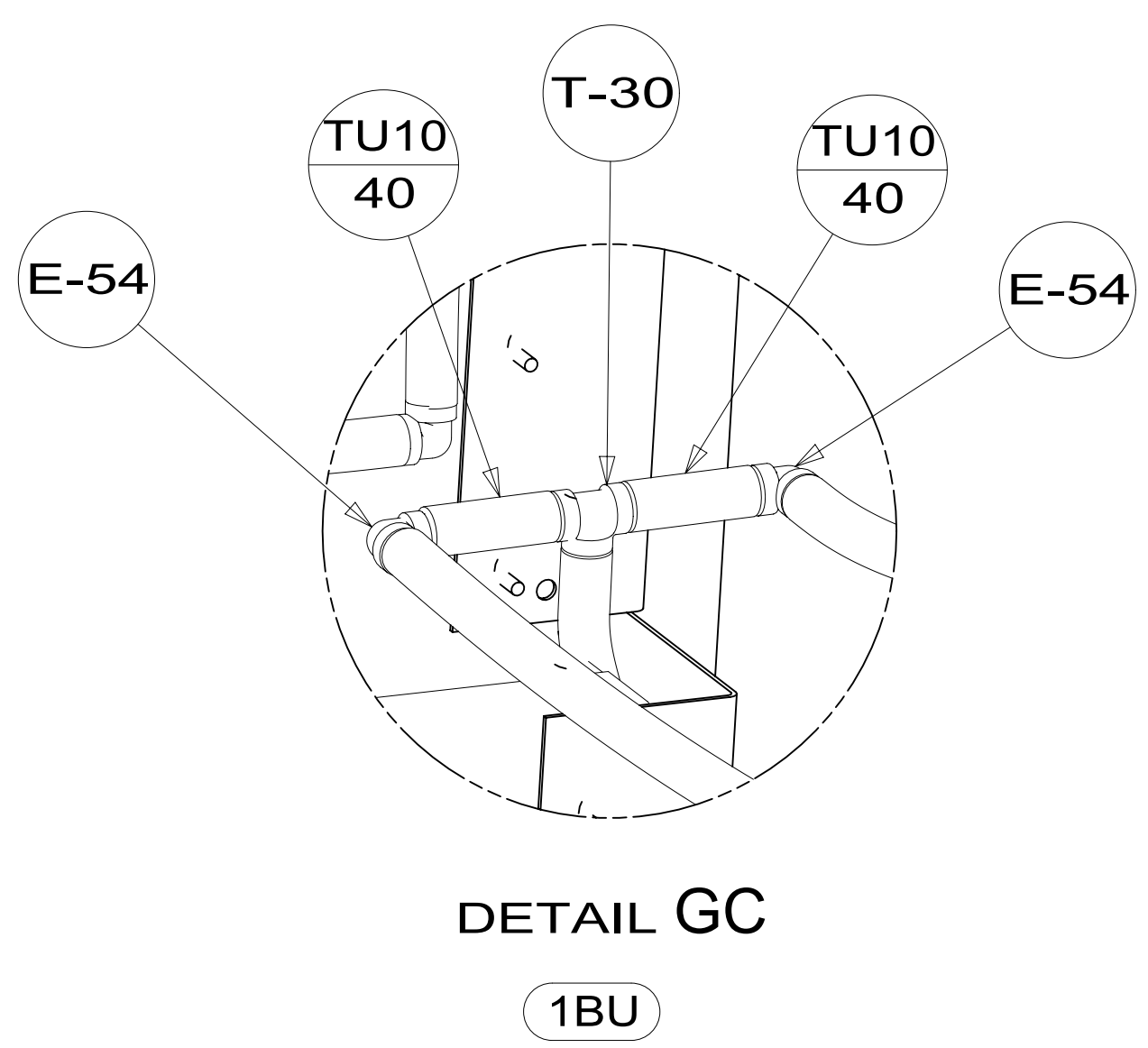

VIEW GB

DESCRIPTION:		
WATER SYSTEM INSTL		
SHEET:	ITEM/PART NO:	REV
7 OF 7	000016839 / 31325301000	