

- 14C FIREPLACE-ELECTRIC
- 78J ELECTRICAL SYSTEM-50 AMP
- 265 CODES/STANDARDS-CSA/CMVSS
- 1B1 CODES/STANDARDS USA

<b>WINNEBAGO</b> COPYRIGHT 2016 WINNEBAGO INDUSTRIES, INC.	
DSNR:	ALL DIMENSIONS ARE IN MILLIMETERS
DFFR:	
UNSPECIFIED TOLERANCES:	MATERIAL:
WHOLE DIM (X) : 3	
ONE-PLACE (X.X) : 1.5	
TWO-PLACE (X.XX) : 0.50	
ANGLE : 1°	
REFER TO ES0018 FOR FASTENER TIGHTENING GUIDELINES	WEIGHT: (LBS) FIRST USED:
	<b>17 L34T</b>
<b>DESCRIPTION:</b> <b>WIRING INSTL-BODY, 110V</b>	
SHEET: 1 OF 6	ITEM/PART NO: 000015725 / 31295201000
REF:	1 02-Apr-2018

- NOTES:**
1. AT MINIMUM ALL WIRES TO BE SUPPORTED AND SECURED PER CODE REQUIREMENTS. USE CLAMP 10495 OR 10497 OR WIRE TIE 8343 OR 108046 AND SCREW G67-XX-XXX OR G56-XX-XXX AS APPROPRIATE FOR INSTALLATION.
  2. CLAMP TO FLOOR SUPPORT TUBES AS NECESSARY WITH CLAMP 10497-01-000.
  3. WIRES THAT REST ON WIRE TRAYS ARE TO BE TIED DOWN WITH WIRE TIE 8343-04-000.

FOR ELECTRICAL TORQUE SPECIFICATIONS SEE DWG NO. 128783-01-000

FOR ELECTRICAL CALLOUTS SEE DWG NO. 121339-01-000

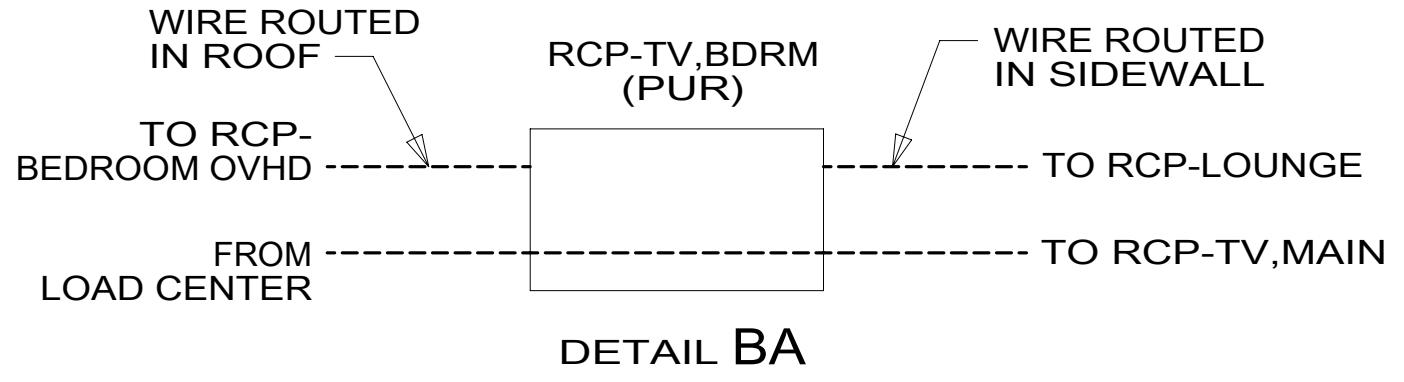
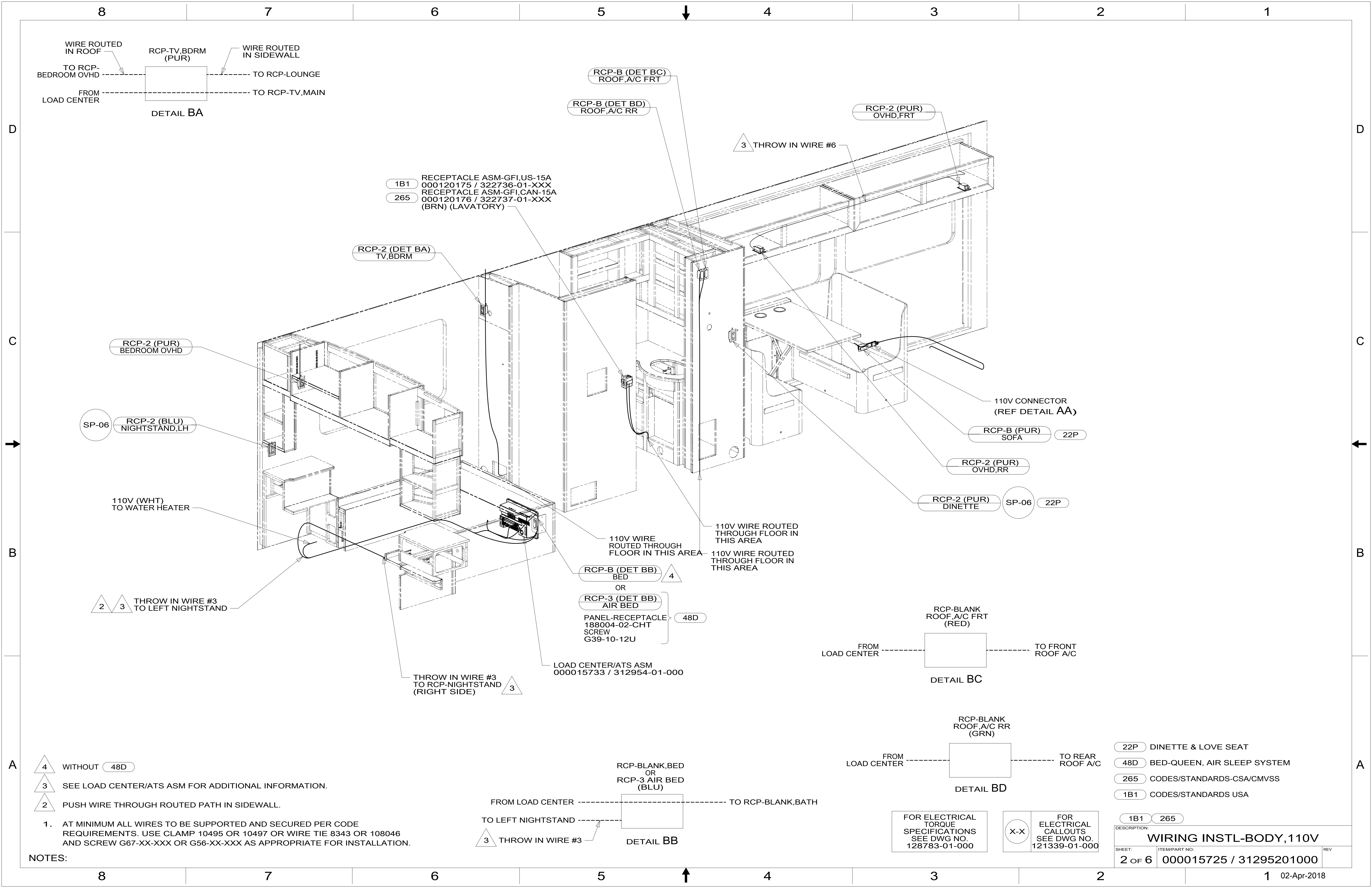

- 1B1 RECEPTACLE ASM-GFI,US-15A  
000120175 / 322736-01-XXX
- 265 RECEPTACLE ASM-GFI,CAN-15A  
000120176 / 322737-01-XXX  
(BRN) (LAVATORY)

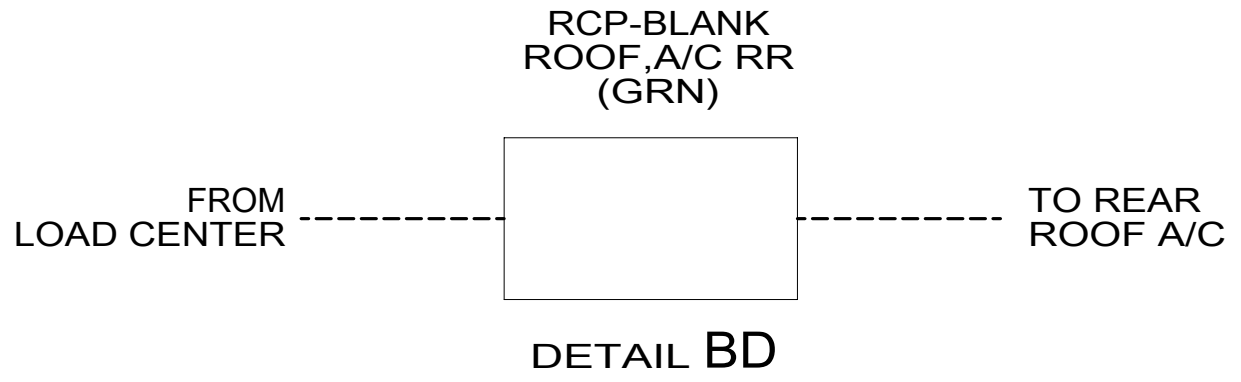
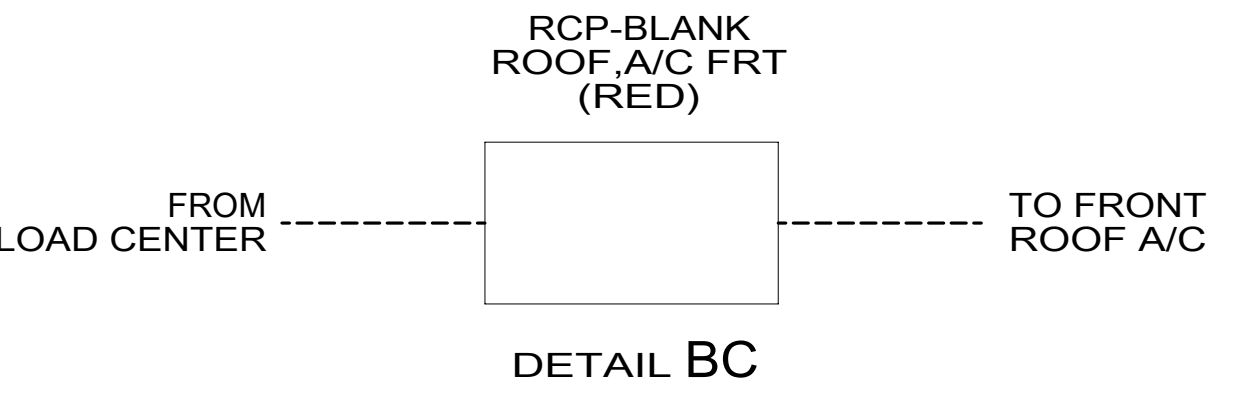
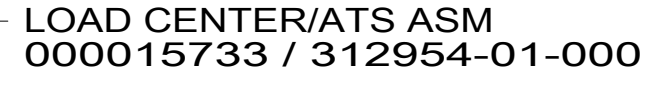
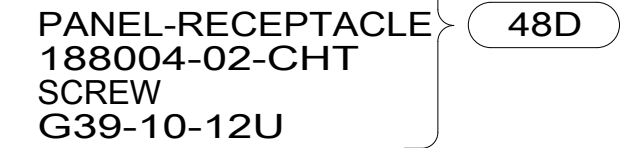
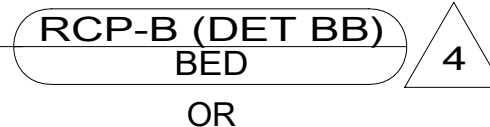
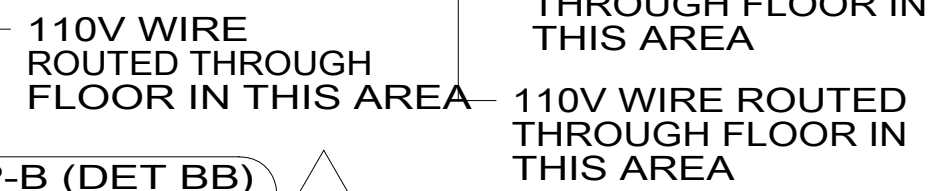
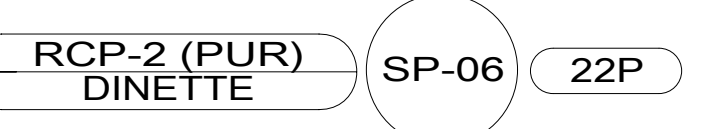
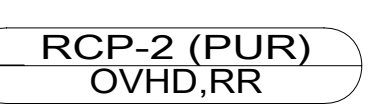
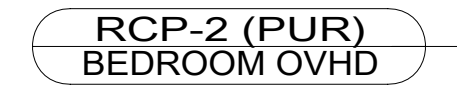
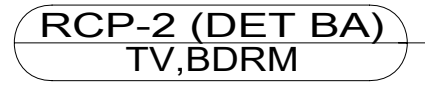

- NOTES:
- AT MINIMUM ALL WIRES TO BE SUPPORTED AND SECURED PER CODE REQUIREMENTS. USE CLAMP 10495 OR 10497 OR WIRE TIE 8343 OR 108046 AND SCREW G67-XX-XXX OR G56-XX-XXX AS APPROPRIATE FOR INSTALLATION.

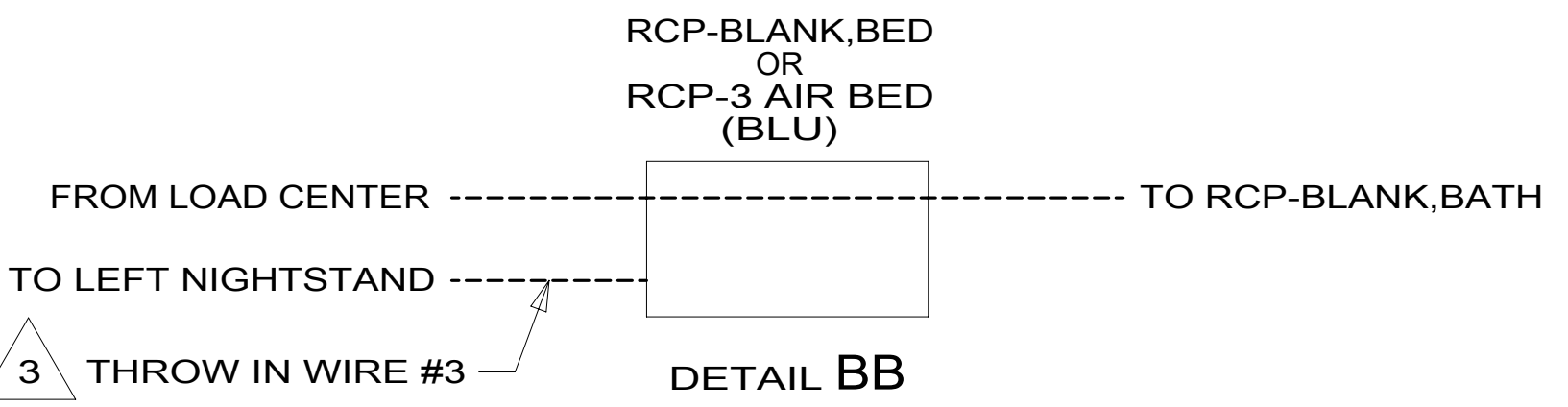

FOR ELECTRICAL TORQUE SPECIFICATIONS SEE DWG NO. 128783-01-000

FOR ELECTRICAL CALLOUTS SEE DWG NO. 121339-01-000

- 22P DINETTE & LOVE SEAT
- 48D BED-QUEEN, AIR SLEEP SYSTEM
- 265 CODES/STANDARDS-CSA/CMVSS
- 1B1 CODES/STANDARDS USA

DESCRIPTION: <b>WIRING INSTL-BODY, 110V</b>		
SHEET: 2 OF 6	ITEM/PART NO: 000015725 / 31295201000	REV

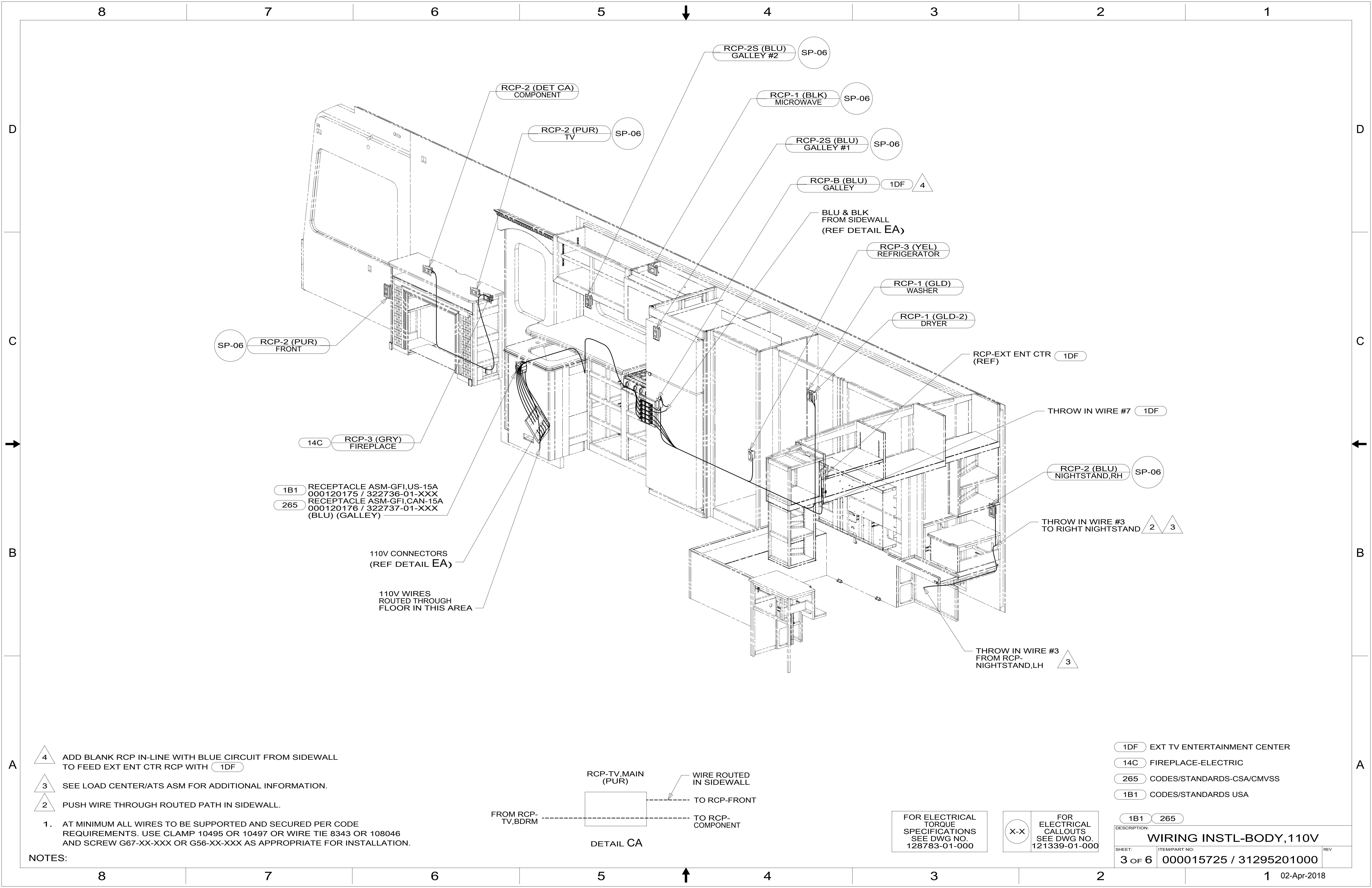

- 4 ADD BLANK RCP IN-LINE WITH BLUE CIRCUIT FROM SIDEWALL TO FEED EXT ENT CTR RCP WITH 1DF
- 3 SEE LOAD CENTER/ATS ASM FOR ADDITIONAL INFORMATION.
- 2 PUSH WIRE THROUGH ROUTED PATH IN SIDEWALL.

1. AT MINIMUM ALL WIRES TO BE SUPPORTED AND SECURED PER CODE REQUIREMENTS. USE CLAMP 10495 OR 10497 OR WIRE TIE 8343 OR 108046 AND SCREW G67-XX-XXX OR G56-XX-XXX AS APPROPRIATE FOR INSTALLATION.

NOTES:

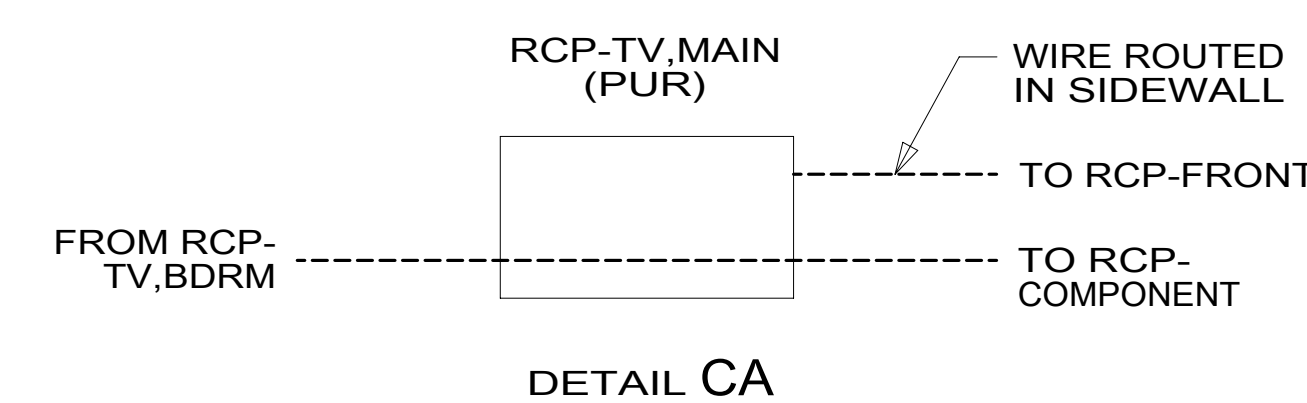

FOR ELECTRICAL TORQUE SPECIFICATIONS SEE DWG NO. 128783-01-000

FOR ELECTRICAL CALLOUTS SEE DWG NO. 121339-01-000

- 1DF EXT TV ENTERTAINMENT CENTER
- 14C FIREPLACE-ELECTRIC
- 265 CODES/STANDARDS-CSA/CMVSS
- 1B1 CODES/STANDARDS USA

DESCRIPTION:		1B1 265	
<b>WIRING INSTL-BODY, 110V</b>			
SHEET:	ITEM/PART NO.:	REV:	
3 OF 6	000015725 / 31295201000		

D

C

B

A

D

C

B

A

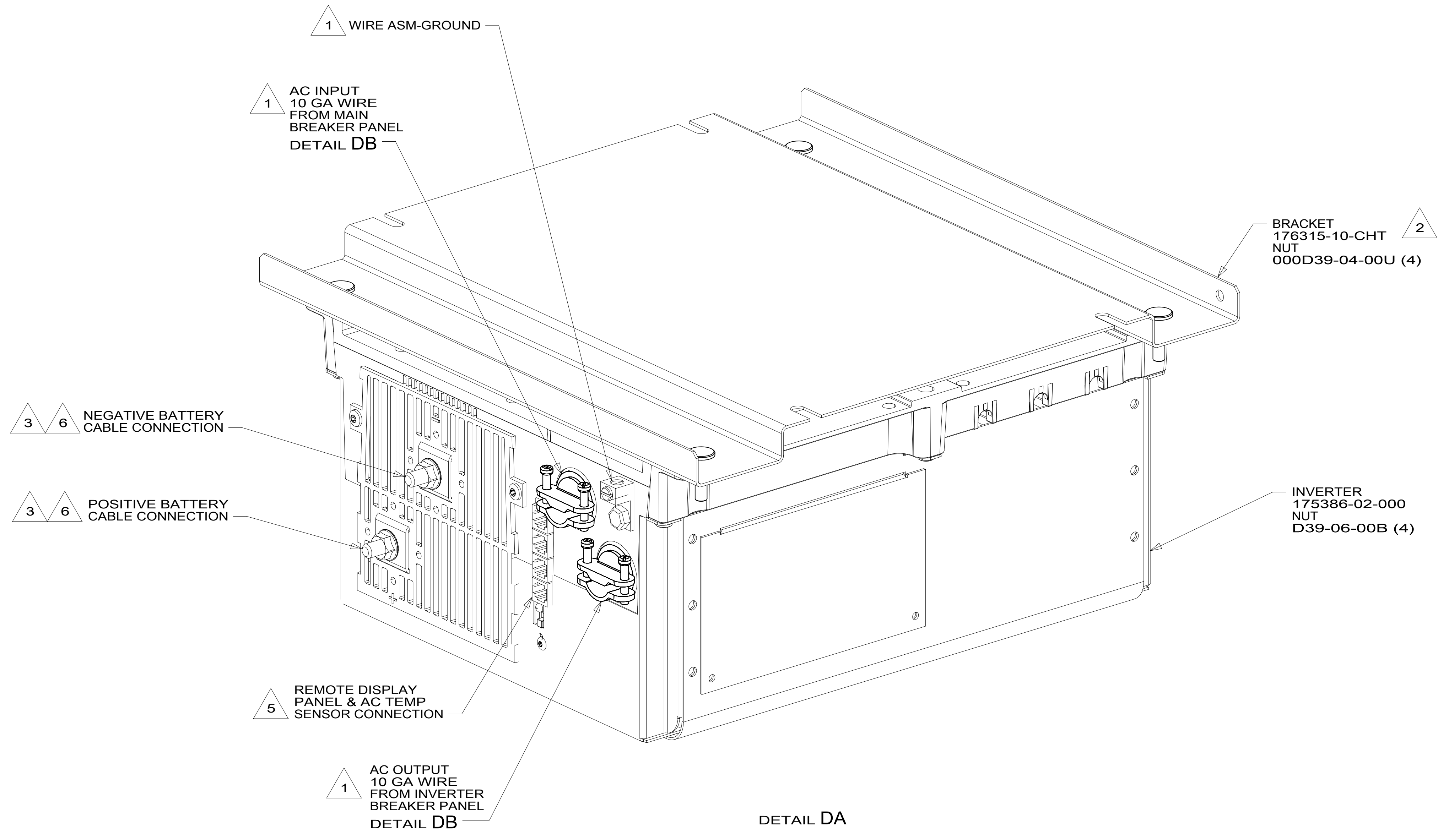

DETAIL DA

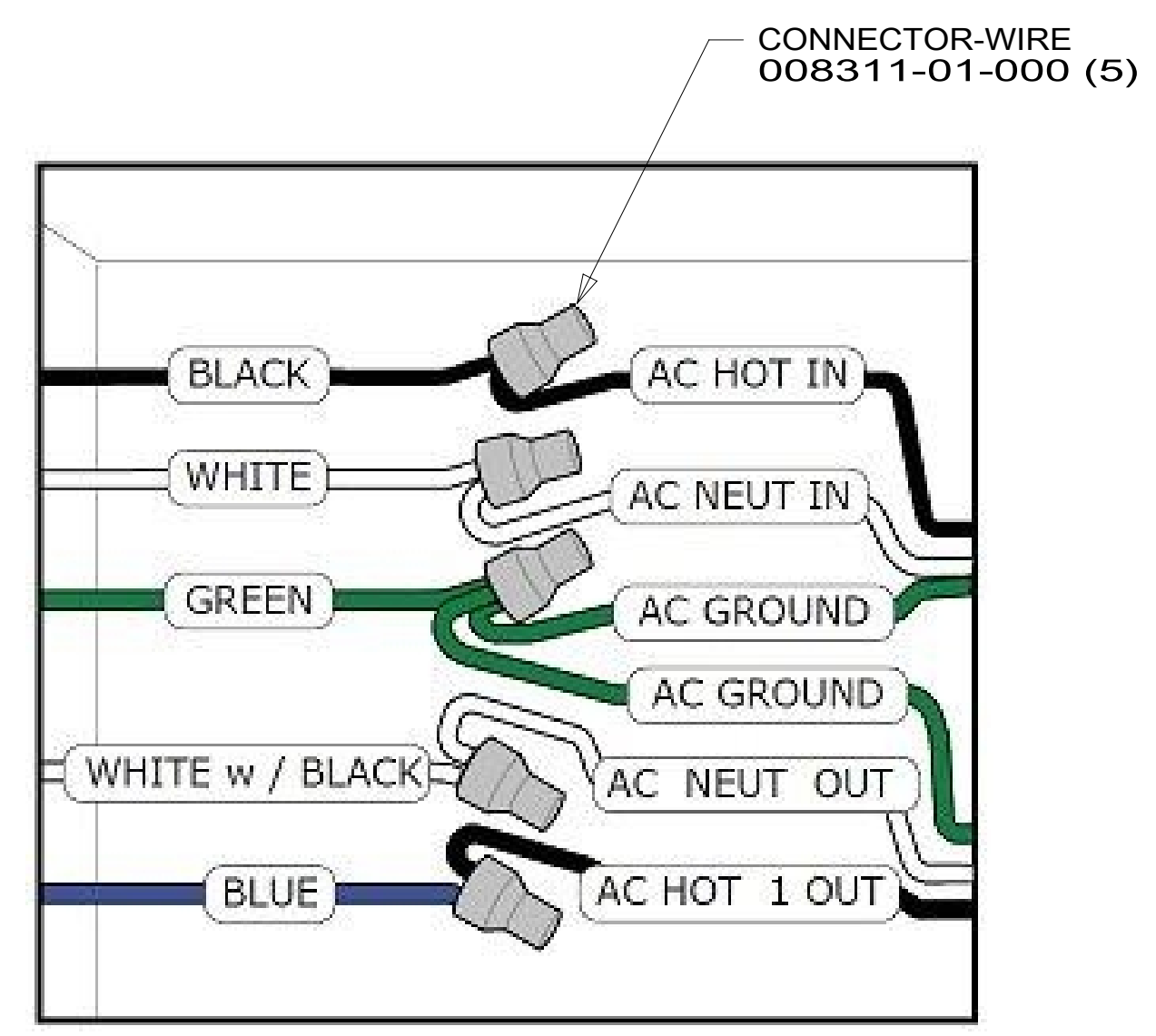

DETAIL DB

- NOTES:
- 6 DO NOT USE POWER/AIR TOOL TO INSTALL NUT. TORQUE TO 10-12 FT LBS.
  - 5 CABLES PART OF WIRE ASM-COACH.
  - 4 SEE INVERTER/CHARGER OWNER'S MANUAL FOR ADDITIONAL INFORMATION.
  - 3 SEE WIRING INSTL-CHASSIS FOR ADDITIONAL INFORMATION.
  - 2 BRACKET IS LOCATED BY HOLES ON BRACKET.
  - 1 SEE LOAD CENTER/ATS ASM FOR ADDITIONAL INFORMATION.

FOR ELECTRICAL  
TORQUE  
SPECIFICATIONS  
SEE DWG NO.  
128783-01-000

FOR  
ELECTRICAL  
CALLOUTS  
SEE DWG NO.  
121339-01-000

- 265 CODES/STANDARDS-CSA/CMVSS
- 1B1 CODES/STANDARDS USA

DESCRIPTION:		1B1 265	
<b>WIRING INSTL-BODY, 110V</b>			
SHEET:	ITEM/PART NO.:	REV	
4 OF 6	000015725 / 31295201000		

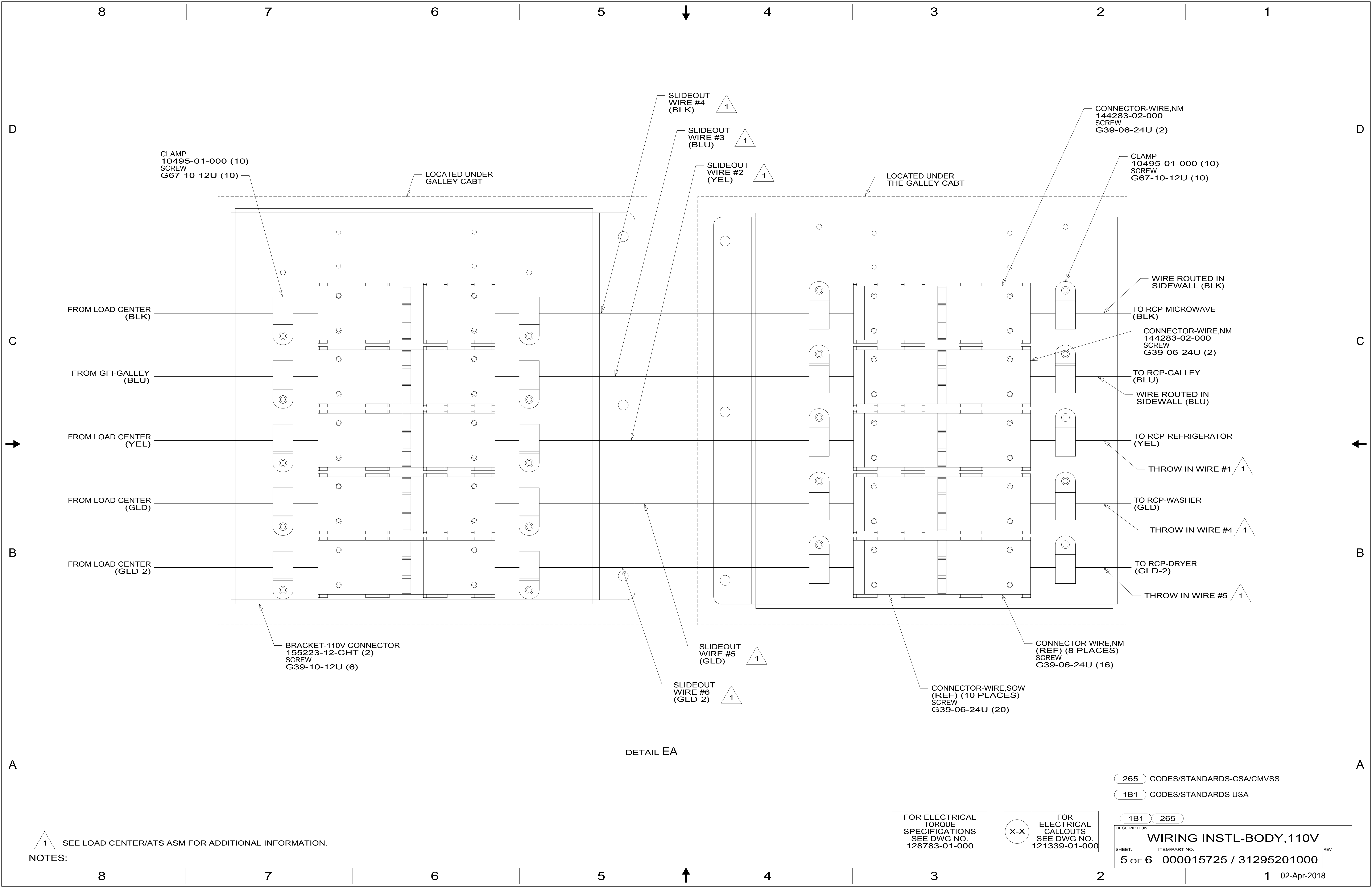

CLAMP  
10495-01-000 (10)  
SCREW  
G67-10-12U (10)

LOCATED UNDER  
GALLEY CABT

SLIDEOUT  
WIRE #4  
(BLK) 1

SLIDEOUT  
WIRE #3  
(BLU) 1

SLIDEOUT  
WIRE #2  
(YEL) 1

LOCATED UNDER  
THE GALLEY CABT

CONNECTOR-WIRE,NM  
144283-02-000  
SCREW  
G39-06-24U (2)

CLAMP  
10495-01-000 (10)  
SCREW  
G67-10-12U (10)

FROM LOAD CENTER  
(BLK)

FROM GFI-GALLEY  
(BLU)

FROM LOAD CENTER  
(YEL)

FROM LOAD CENTER  
(GLD)

FROM LOAD CENTER  
(GLD-2)

WIRE ROUTED IN  
SIDEWALL (BLK)

TO RCP-MICROWAVE  
(BLK)

CONNECTOR-WIRE,NM  
144283-02-000  
SCREW  
G39-06-24U (2)

TO RCP-GALLEY  
(BLU)

WIRE ROUTED IN  
SIDEWALL (BLU)

TO RCP-REFRIGERATOR  
(YEL)

THROW IN WIRE #1 1

TO RCP-WASHER  
(GLD)

THROW IN WIRE #4 1

TO RCP-DRYER  
(GLD-2)

THROW IN WIRE #5 1

BRACKET-110V CONNECTOR  
155223-12-CHT (2)  
SCREW  
G39-10-12U (6)

SLIDEOUT  
WIRE #5  
(GLD) 1

SLIDEOUT  
WIRE #6  
(GLD-2) 1

CONNECTOR-WIRE,NM  
(REF) (8 PLACES)  
SCREW  
G39-06-24U (16)

CONNECTOR-WIRE,SOW  
(REF) (10 PLACES)  
SCREW  
G39-06-24U (20)

DETAIL EA

265 CODES/STANDARDS-CSA/CMVSS

1B1 CODES/STANDARDS USA

1B1 265

1 SEE LOAD CENTER/ATS ASM FOR ADDITIONAL INFORMATION.

FOR ELECTRICAL  
TORQUE  
SPECIFICATIONS  
SEE DWG NO.  
128783-01-000

FOR ELECTRICAL  
CALLOUTS  
SEE DWG NO.  
121339-01-000

DESCRIPTION: <b>WIRING INSTL-BODY, 110V</b>		
SHEET: 5 OF 6	ITEM/PART NO: 000015725 / 31295201000	REV

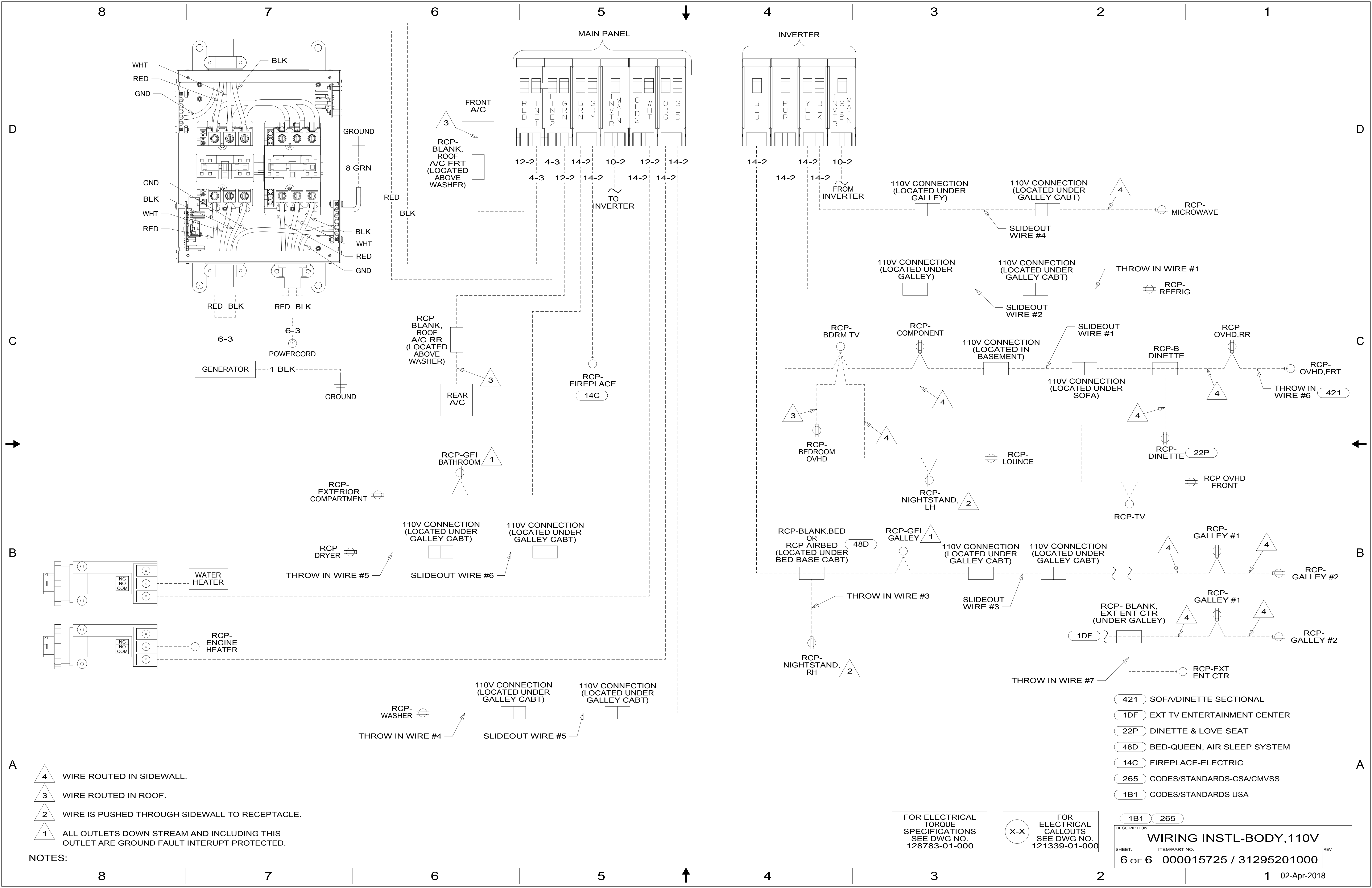

- NOTES:
- 4 WIRE ROUTED IN SIDEWALL.
  - 3 WIRE ROUTED IN ROOF.
  - 2 WIRE IS PUSHED THROUGH SIDEWALL TO RECEPTACLE.
  - 1 ALL OUTLETS DOWN STREAM AND INCLUDING THIS OUTLET ARE GROUND FAULT INTERRUPT PROTECTED.

FOR ELECTRICAL TORQUE SPECIFICATIONS SEE DWG NO. 128783-01-000

FOR ELECTRICAL CALLOUTS SEE DWG NO. 121339-01-000

- 421 SOFA/DINETTE SECTIONAL
- 1DF EXT TV ENTERTAINMENT CENTER
- 22P DINETTE & LOVE SEAT
- 48D BED-QUEEN, AIR SLEEP SYSTEM
- 14C FIREPLACE-ELECTRIC
- 265 CODES/STANDARDS-CSA/CMVSS
- 1B1 CODES/STANDARDS USA

DESCRIPTION:		1B1 265	
<b>WIRING INSTL-BODY, 110V</b>			
SHEET:	ITEM/PART NO.:	REV	
6 OF 6	000015725 / 31295201000		