

- 11P SOFA/SLEEPER-PRIMERA
- 22L DINETTE UPGRADE
- 14W DINETTE
- 401 INVERTER-DC/AC, 1000 WATT
- 29J AC HEAT PUMP-1
- 25Q A/C ROOF AIR (1) 14,800 BTU
- 265 CODES/STANDARDS-CSA/CMVSS
- 1B1 CODES/STANDARDS USA

2 WIRE PASSES THROUGH FLOOR IN THIS AREA.

1. AT MINIMUM ALL WIRES TO BE SUPPORTED AND SECURED PER CODE REQUIREMENTS. USE CLAMP 10495 OR 10497 OR WIRE TIE 8343 OR 108046 AND SCREW G67-XX-XXX OR G56-XX-XXX AS APPROPRIATE FOR INSTALLATION.

NOTES:

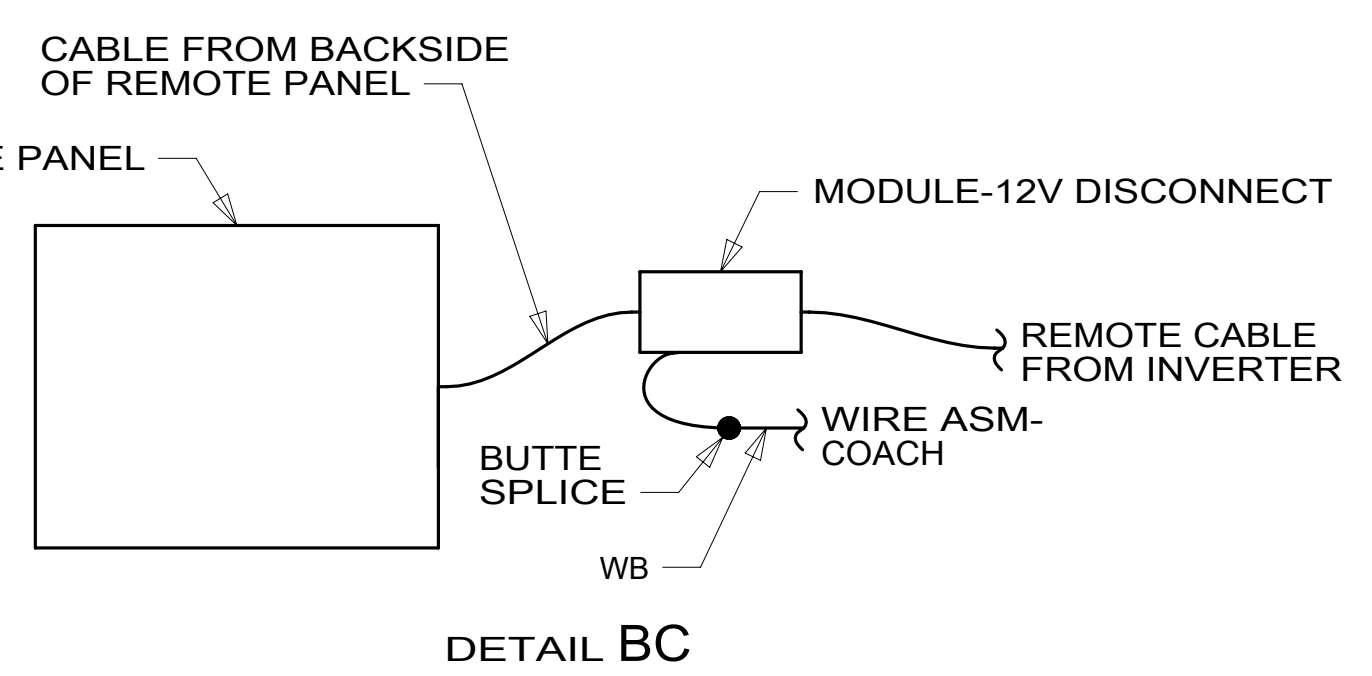

FOR ELECTRICAL TORQUE SPECIFICATIONS SEE DWG NO. 128783-01-000

FOR ELECTRICAL CALLOUTS SEE DWG NO. 121339-01-000

DESCRIPTION:		1B1 265	
WIRING INSTL-BODY, 12V			
SHEET:	ITEM/PART NO.:	REV	
2 OF 7	000213810 / 30291401000		

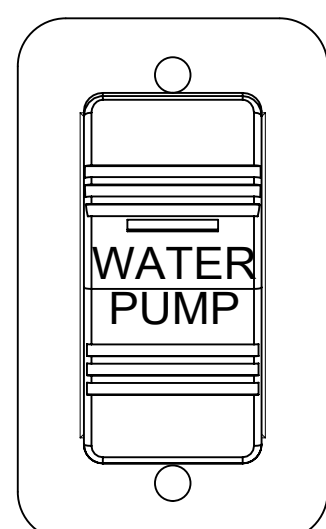

SWITCH-PUMP
108357-15-000
ACTUATOR
108356-23-CHT
PLATE
98351-07-CHT
SCREW
G11-06-10U (2)

DETAIL DA
(2 PLACES)

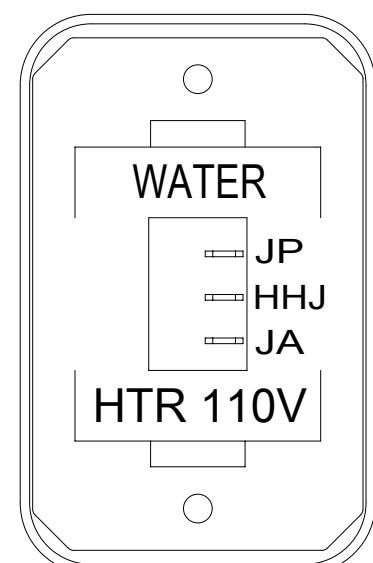

SWITCH-ROCKER
135740-06-CHT
SWITCH-BASE
135741-01-CHT
SWITCH-BEZEL
135742-35-CHT
SCREW
G11-08-08U (2)

DETAIL DF

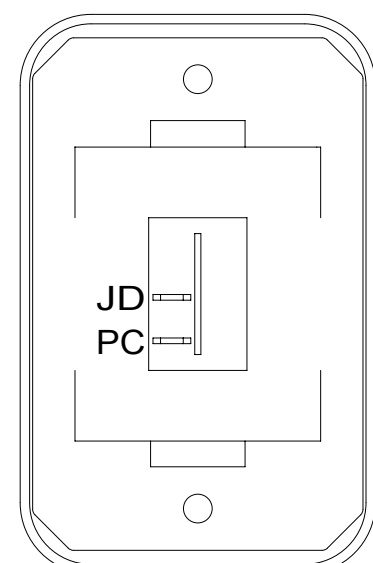

SWITCH-ROCKER
135740-01-CHT
SWITCH-BASE
135741-01-CHT
SWITCH-BEZEL
135742-01-CHT
SCREW
G11-08-08U (2)

DETAIL DN

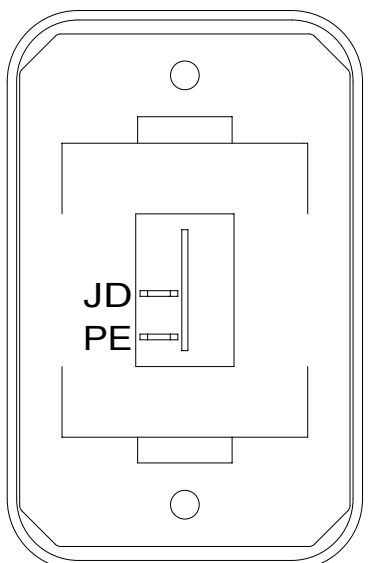

SWITCH-ROCKER
135740-01-CHT
SWITCH-BASE
135741-01-CHT
SWITCH-BEZEL
135742-01-CHT
SCREW
G11-08-08U (2)

DETAIL DB

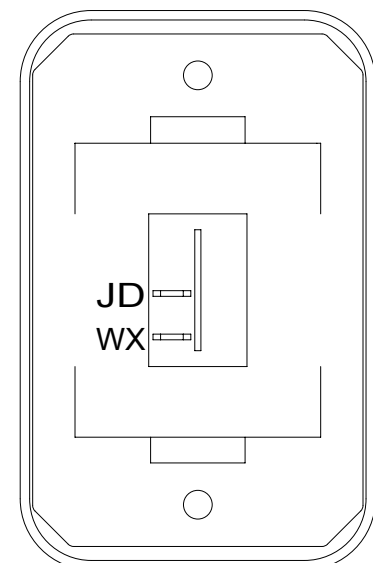

SWITCH-ROCKER
135740-01-CHT
SWITCH-BASE
135741-01-CHT
SWITCH-BEZEL
135742-01-CHT
SCREW
G11-08-08U (2)

DETAIL DJ

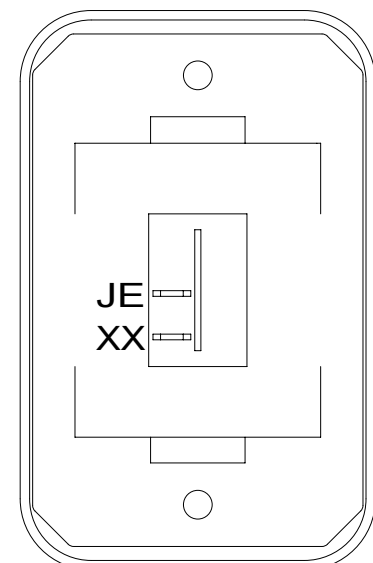

SWITCH-ROCKER
135740-01-CHT
SWITCH-BASE
135741-01-CHT
SWITCH-BEZEL
135742-01-CHT
SCREW
G11-08-08U (2)

DETAIL DP

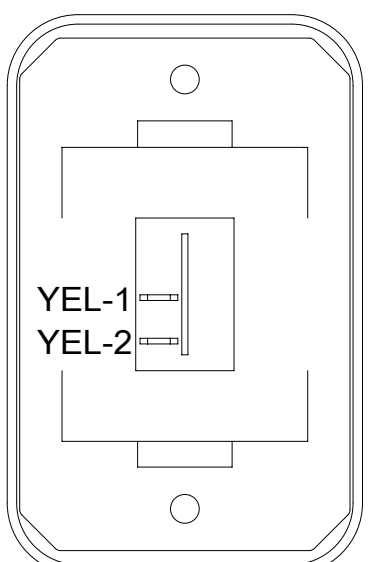

SWITCH-ROCKER
135740-01-CHT
SWITCH-BASE
135741-01-CHT
SWITCH-BEZEL
135742-01-CHT
SCREW
G11-08-08U (2)

DETAIL DC

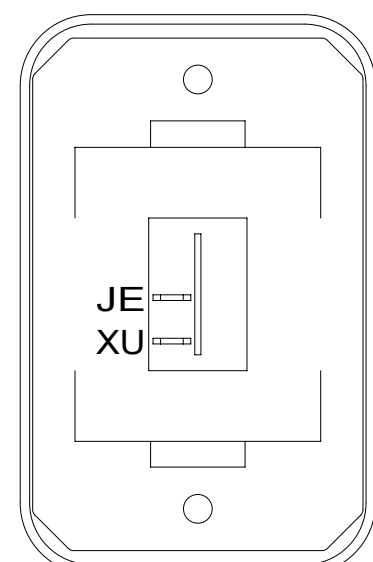

SWITCH-ROCKER
135740-01-CHT
SWITCH-BASE
135741-01-CHT
SWITCH-BEZEL
135742-01-CHT
SCREW
G11-08-08U (2)

DETAIL DK

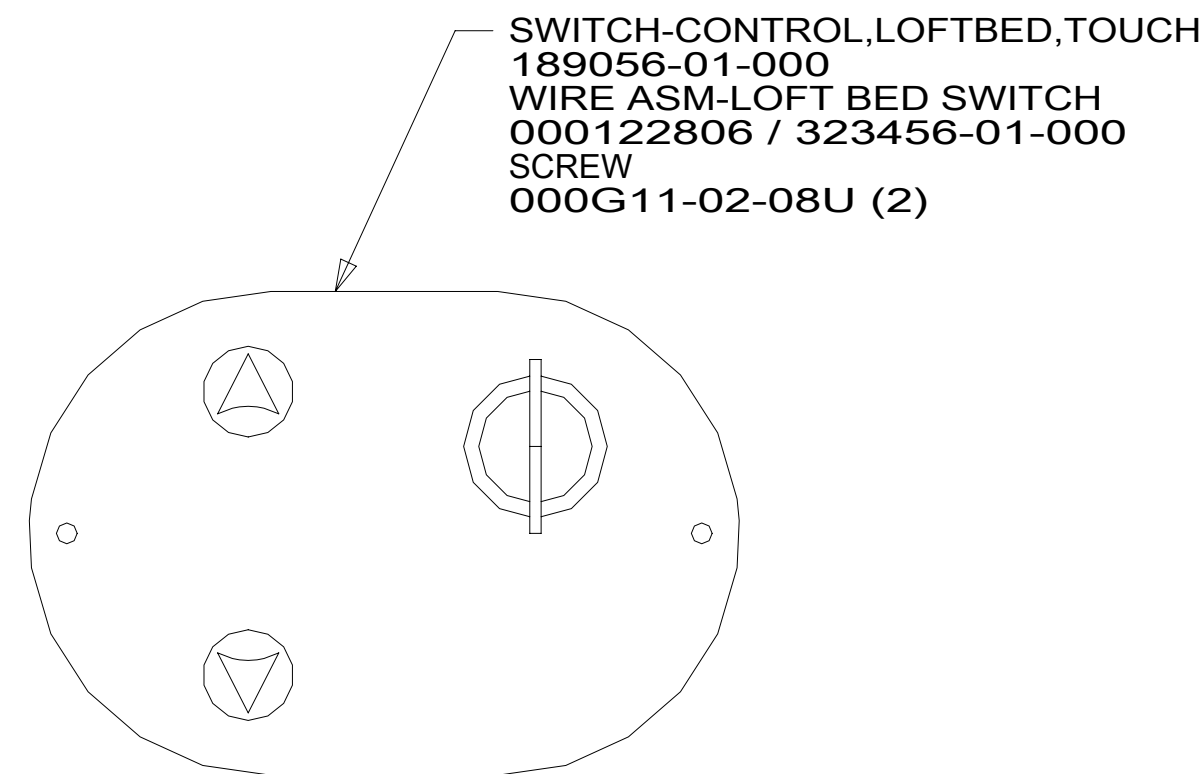

DETAIL DR (45B)

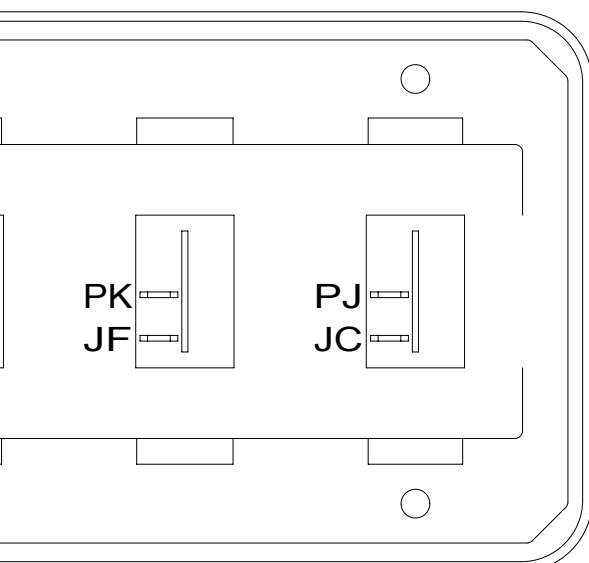

SWITCH-ROCKER
135740-01-CHT (3)
SWITCH-BASE
135741-03-CHT
SWITCH-BEZEL
135742-03-CHT
SCREW
G11-08-08U (4)

DETAIL DD

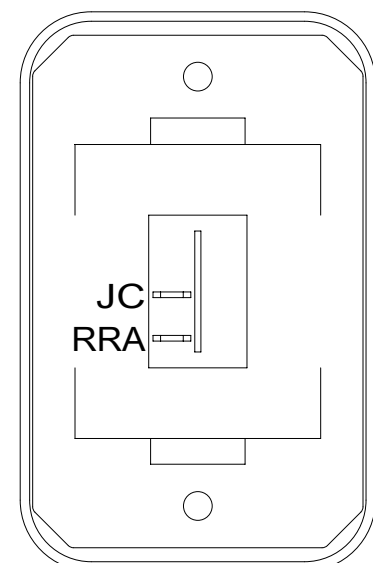

SWITCH-ROCKER
135740-01-CHT
SWITCH-BASE
135741-01-CHT
SWITCH-BEZEL
135742-01-CHT
SCREW
G11-08-08U (2)

DETAIL DL

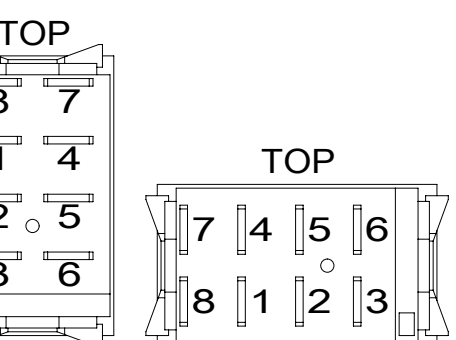

DETAIL DE

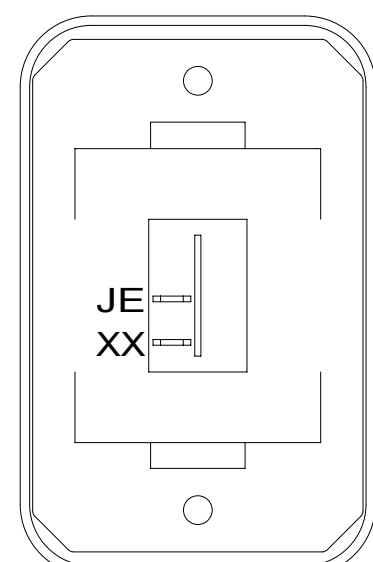

SWITCH-ROCKER
135740-01-CHT
SWITCH-BASE
135741-01-CHT
SWITCH-BEZEL
135742-01-CHT
SCREW
G11-08-08U (2)

DETAIL DM

LABEL-WARNING,SLIDEOUT
116549-01-000

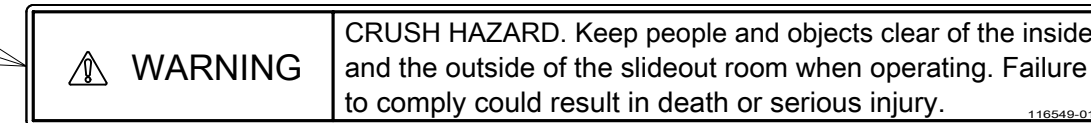

SWITCH-ROCKER
108357-07-000
ACTUATOR-SWITCH
108356-24-CHT
CIRCUITS
BBM,DT,BBN

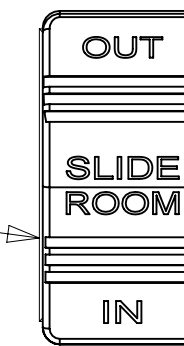

SWITCH
108357-18-000
ACTUATOR
108356-31-CHT
CIRCUITS
DU,KE,DR,ABY,ABZ

SWITCH
108357-18-000
ACTUATOR
108356-31-CHT
CIRCUITS
HHH,KE,HHG,ACC,ACD

LABEL-SLIDEOUT,
DRIVER,REAR
163992-02-CHT



LABEL-SLIDEOUT
PASS,REAR
163992-03-CHT

LABEL-SLIDEOUT,
DRIVER,FRONT
163992-01-CHT

DETAIL DG

SWITCH-AWNING
108357-14-000
ACTUATOR-SWITCH
108356-28-CHT
CIRCUITS
SP,ZZL,WE,ZZL

PLATE-SWITCH
303611-01-CHT
SEAL-FUSE BOX
092492-25-000
SCREW
000G11-06-10U (6)

SWITCH-AWNING
108357-06-000
ACTUATOR-SWITCH
108356-12-CHT
CIRCUITS
FFD,FFR,FFE,
FFE,JJR,FFD

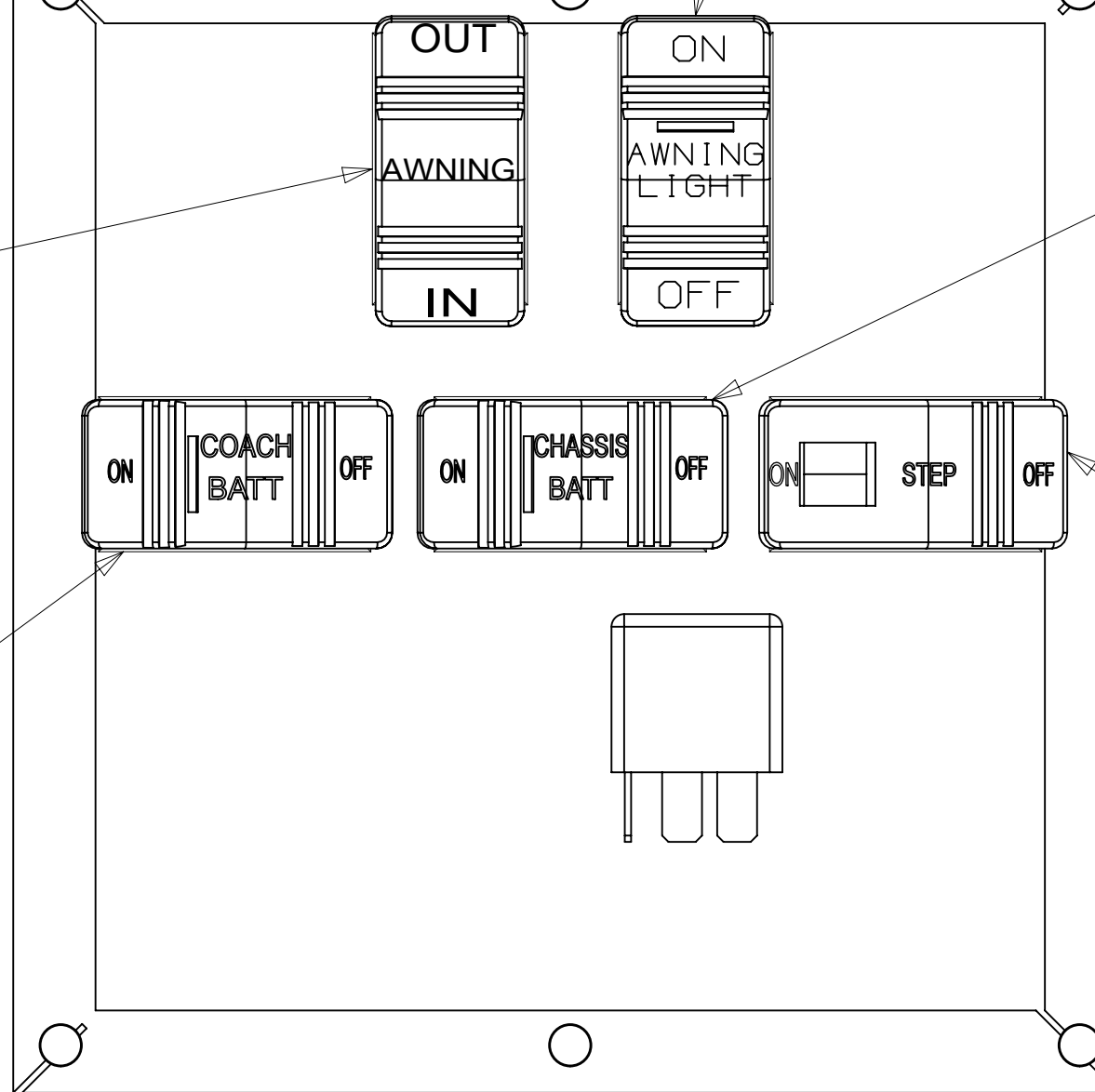

DETAIL DH (1)

SWITCH-COACH BATT
108357-18-000
ACTUATOR-SWITCH
108356-19-CHT
CIRCUITS
KF,LG,LJ,LH,WC
WIRE ASM-THERM
186796-01-000

SWITCH-CHASSIS BATTERY
108357-18-000
ACTUATOR-SWITCH
108356-20-CHT
CIRCUITS
UUC,TTY,UUB
UUB,TTZ,MK
WIRE ASM-THERM
186796-01-000

SWITCH-STEP
108357-19-000
CIRCUITS
ER,ES

2 PLACE AROUND ENTIRE PERIMETER WITH SEAM AT BOTTOM.

1 FOR SWITCH ORIENTATION SEE DETAIL DE

NOTES:

FOR ELECTRICAL TORQUE SPECIFICATIONS SEE DWG NO. 128783-01-000

FOR ELECTRICAL CALLOUTS SEE DWG NO. 121339-01-000

45B LOFT BED
265 CODES/STANDARDS-CSA/CMVSS
1B1 CODES/STANDARDS USA

DESCRIPTION:
1B1 265
WIRING INSTL-BODY, 12V

SHEET: 4 OF 7 ITEM/PART NO: 000213810 / 30291401000 REV

8

7

6

5

4

3

2

1

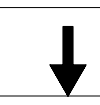

D

D

C

C

B

B

A

A

SPEAKER
180783-01-CHT (2)
SCREW
000G11-08-12U (8)

PRLED-4
7

PRLED-2
2

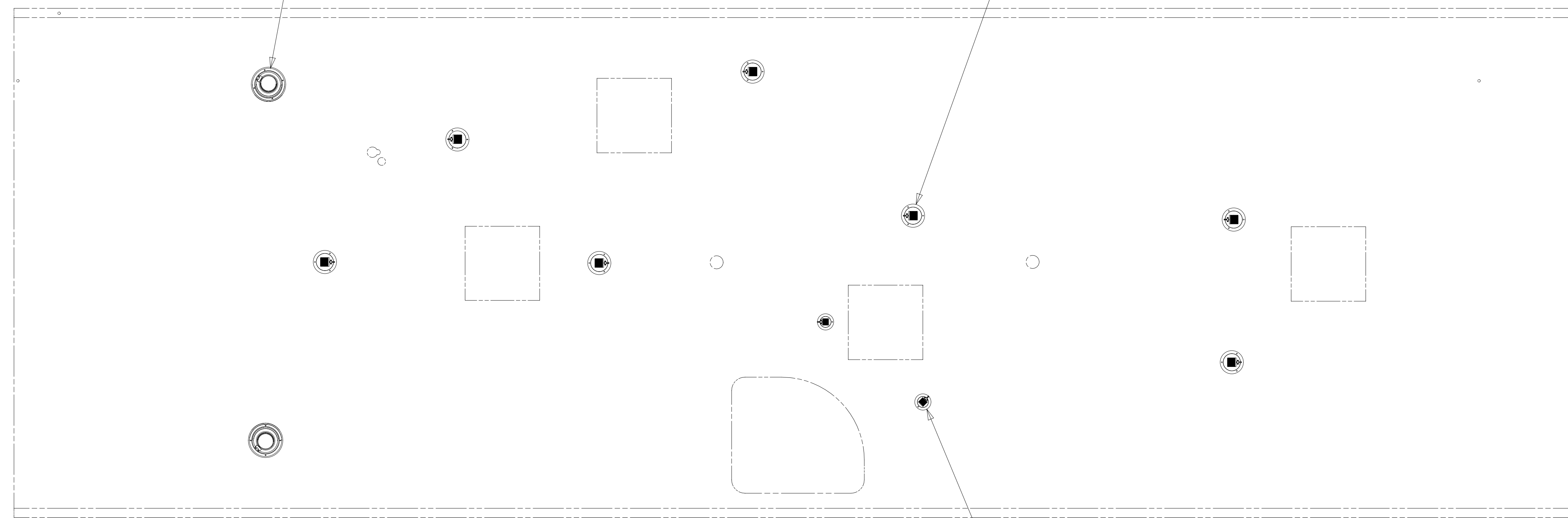

265 CODES/STANDARDS-CSA/CMVSS
1B1 CODES/STANDARDS USA

FOR ELECTRICAL
TORQUE
SPECIFICATIONS
SEE DWG NO.
128783-01-000

FOR
ELECTRICAL
CALLOUTS
SEE DWG NO.
121339-01-000

1B1 265	
DESCRIPTION: WIRING INSTL-BODY, 12V	
SHEET: 5 OF 7	ITEM/PART NO: 000213810 / 30291401000
REV	

8

7

6

5

4

3

2

1 14-Sep-2017



8 7 6 5 4 3 2 1

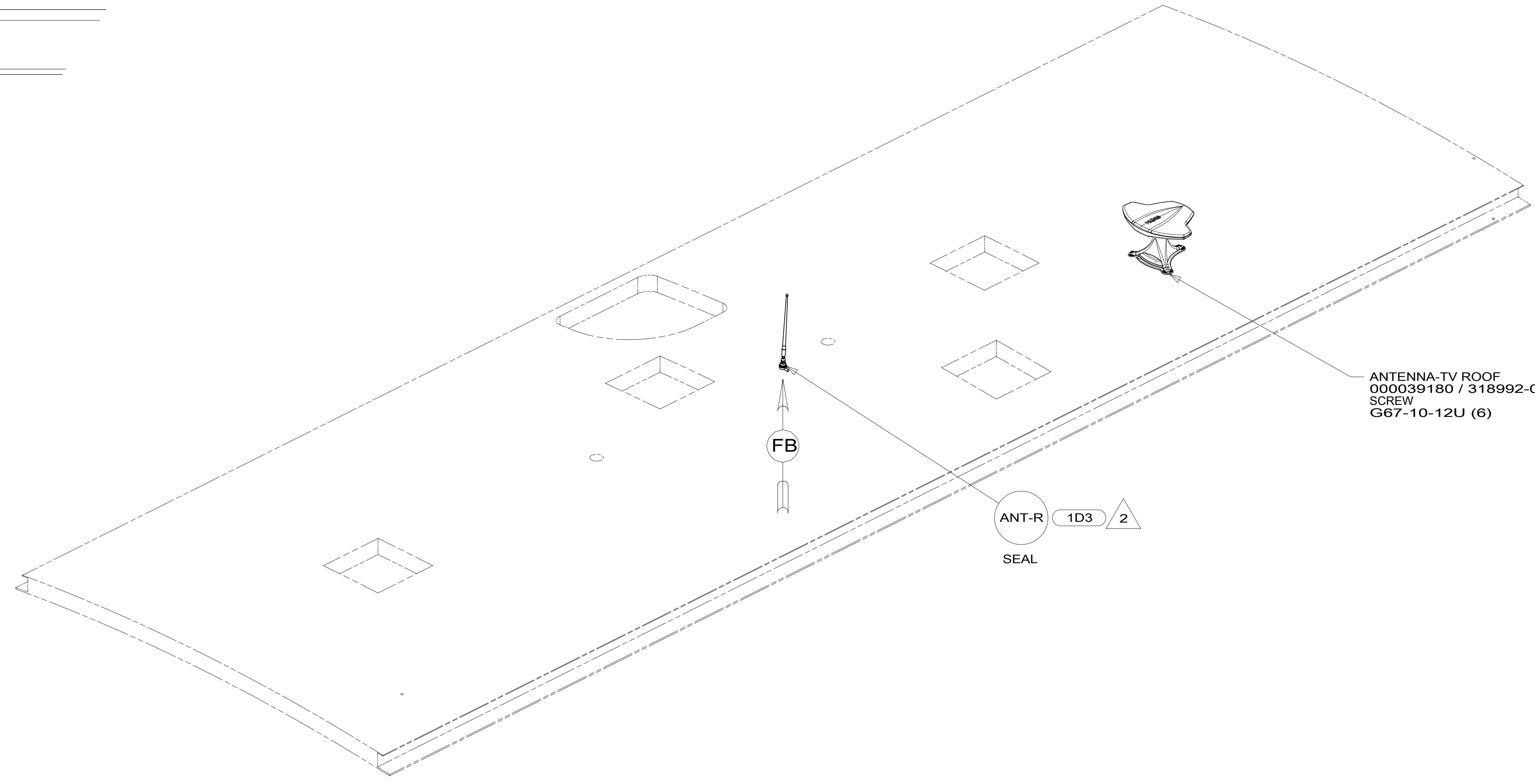
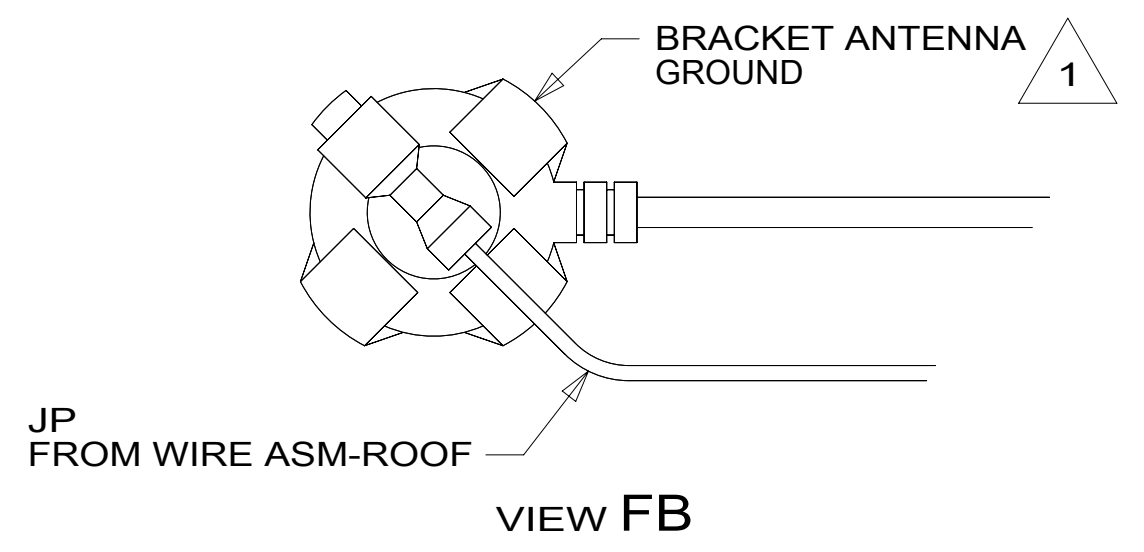
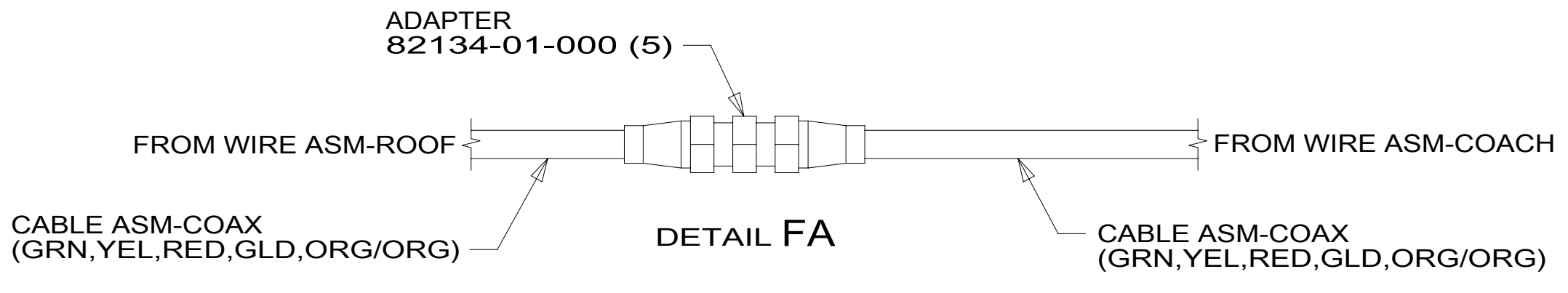

- NOTES:
- 2 REMOVE GROUND WIRE FROM ANTENNA BASE.
 - 1 WRAP LEGS AROUND ANTENNA BASE.

FOR ELECTRICAL
TORQUE
SPECIFICATIONS
SEE DWG NO.
128783-01-000

FOR
ELECTRICAL
CALLOUTS
SEE DWG NO.
121339-01-000

- 1D3 ENTERTAIN CENTR/EXT TV-DVD
- 265 CODES/STANDARDS-CSA/CMVSS
- 1B1 CODES/STANDARDS USA

DESCRIPTION:		1B1 265	
WIRING INSTL-BODY, 12V			
SHEET:	ITEM/PART NO.:	REV	
6 OF 7	000213810 / 30291401000		

8 7 6 5 4 3 2 1 14-Sep-2017

8 7 6 5 4 3 2 1

D
C
B
A

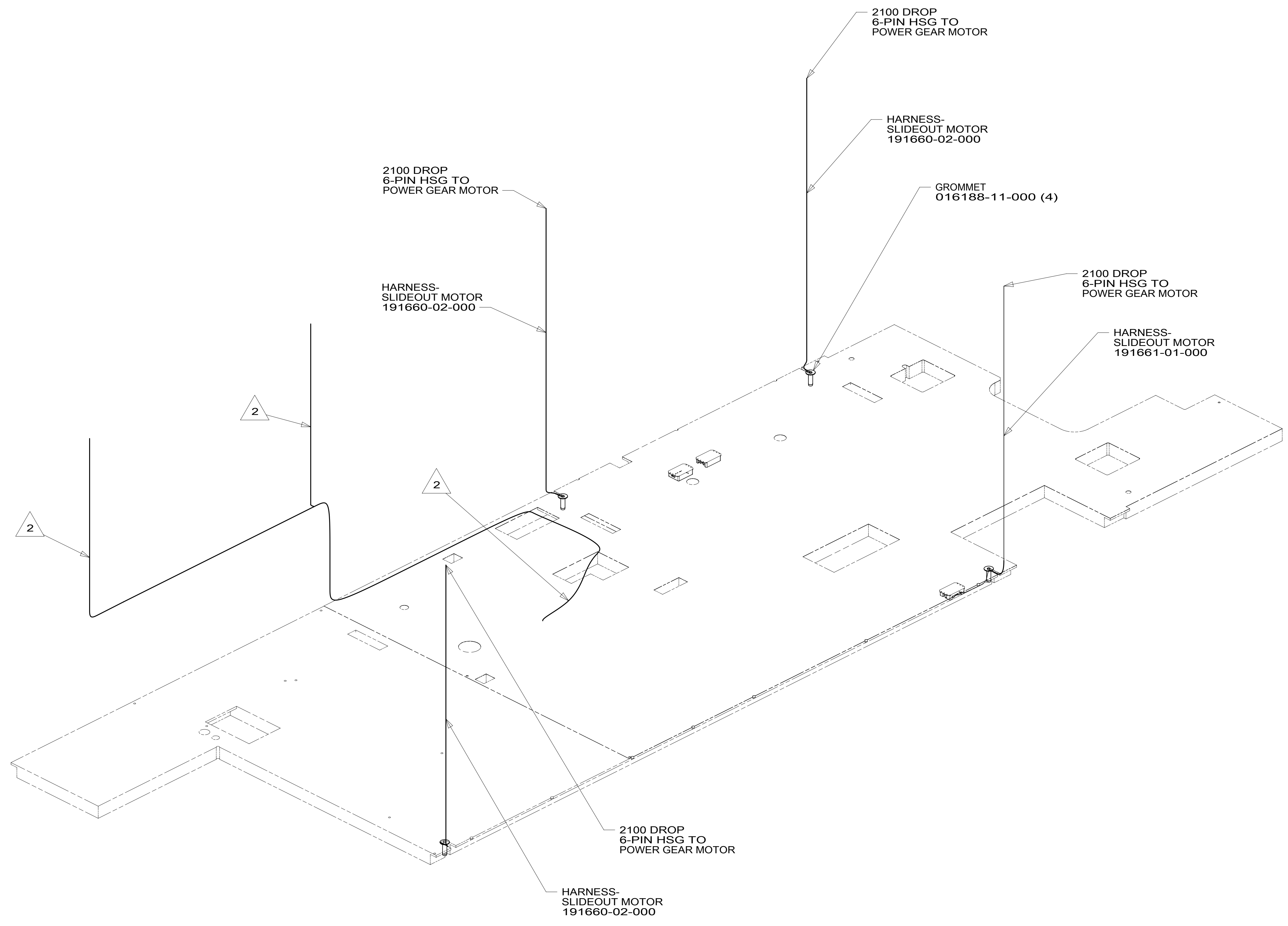

 WIRING PART OF WIRE ASM-CHASSIS.

1. AT MINIMUM ALL WIRES TO BE SUPPORTED AND SECURED PER CODE REQUIREMENTS. USE CLAMP 10495 OR 10497 OR WIRE TIE 8343 OR 108046 AND SCREW G67-XX-XXX OR G56-XX-XXX AS APPROPRIATE FOR INSTALLATION.

NOTES:

265 CODES/STANDARDS-CSA/CMVSS
 1B1 CODES/STANDARDS USA

FOR ELECTRICAL TORQUE SPECIFICATIONS SEE DWG NO. 128783-01-000

FOR ELECTRICAL CALLOUTS SEE DWG NO. 121339-01-000

1B1 265	
DESCRIPTION: WIRING INSTL-BODY, 12V	
SHEET: 7 OF 7	ITEM/PART NO: 000213810 / 30291401000
REV	

8 7 6 5 4 3 2 1 14-Sep-2017