

- 4 SEE LOAD CENTER/ATS ASM FOR ADDITIONAL INFORMATION.
- 3 WIRE PASSES THROUGH FLOOR AT THIS POINT.
2. SEE WIRING DIAGRAM-BODY, 12V FOR ADDITIONAL INFORMATION.
1. AT MINIMUM ALL WIRES TO BE SUPPORTED AND SECURED PER CODE REQUIREMENTS. USE CLAMP 10495 OR 10497 OR WIRE TIE 8343 OR 108046 AND SCREW G67-XX-XXX OR G56-XX-XXX AS APPROPRIATE FOR INSTALLATION.

NOTES:

FOR ELECTRICAL TORQUE SPECIFICATIONS SEE DWG NO. 128783-01-000

FOR ELECTRICAL CALLOUTS SEE DWG NO. 121339-01-000

- 265 CODES/STANDARDS-CSA/CMVSS
- 1B1 CODES/STANDARDS USA

DESCRIPTION:		1B1 265	
WIRING INSTL-BODY, 12V			
SHEET:	ITEM/PART NO.:	REV	
2 OF 9	000213352 / 30186501000		

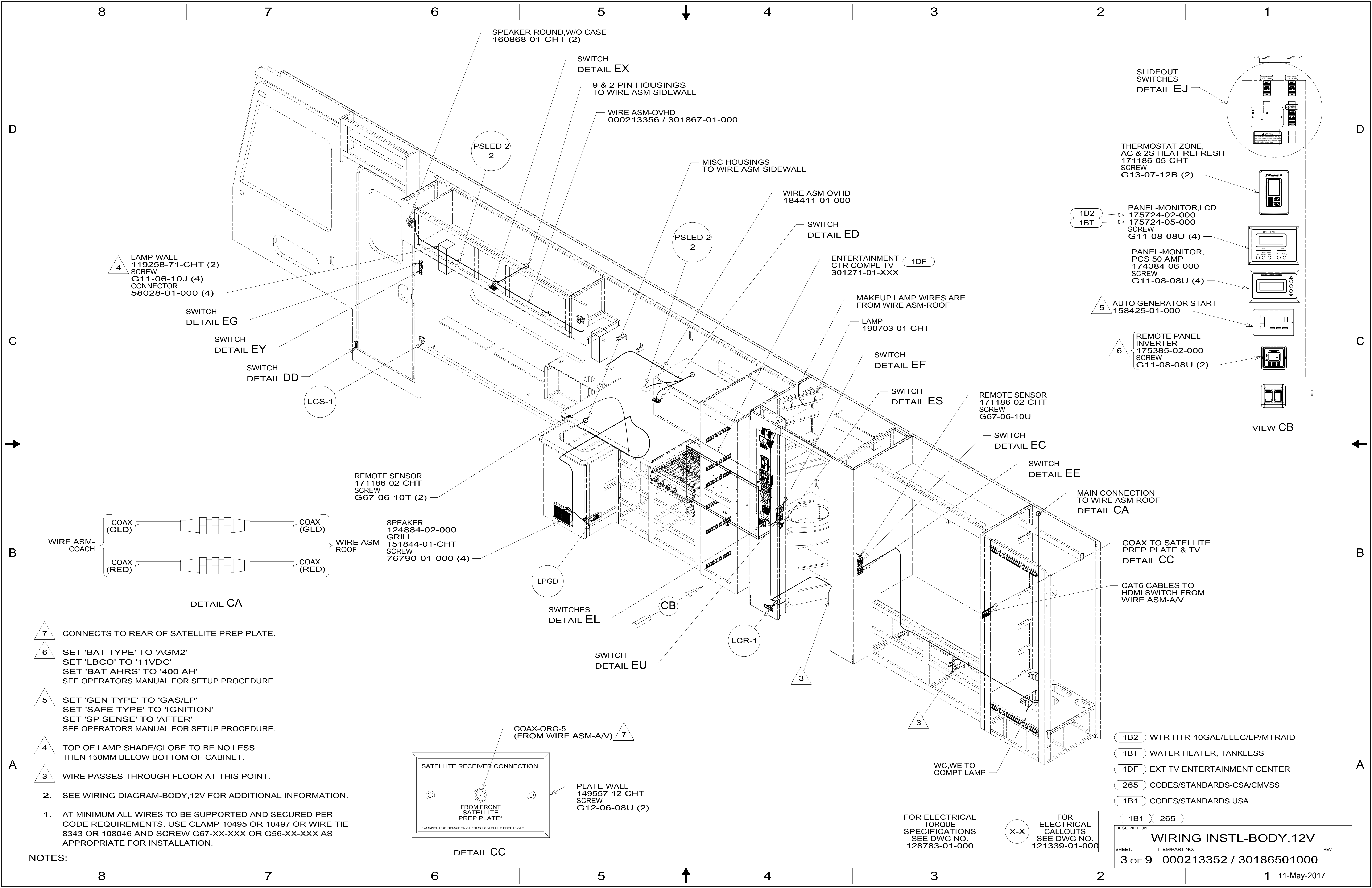

4 LAMP-WALL
119258-71-CHT (2)
SCREW
G11-06-10J (4)
CONNECTOR
58028-01-000 (4)

SWITCH
DETAIL EG
SWITCH
DETAIL EY
SWITCH
DETAIL DD
LCS-1

PSLED-2
2

SWITCH
DETAIL EX
9 & 2 PIN HOUSINGS
TO WIRE ASM-SIDEWALL

WIRE ASM-OVHD
000213356 / 301867-01-000

MISC HOUSINGS
TO WIRE ASM-SIDEWALL

PSLED-2
2

WIRE ASM-OVHD
184411-01-000

SWITCH
DETAIL ED

ENTERTAINMENT
CTR COMPL-TV
301271-01-XXX
1DF

MAKEUP LAMP WIRES ARE
FROM WIRE ASM-ROOF

LAMP
190703-01-CHT

SWITCH
DETAIL EF

SWITCH
DETAIL ES

REMOTE SENSOR
171186-02-CHT
SCREW
G67-06-10U

SWITCH
DETAIL EC

SWITCH
DETAIL EE

MAIN CONNECTION
TO WIRE ASM-ROOF
DETAIL CA

COAX TO SATELLITE
PREP PLATE & TV
DETAIL CC

CAT6 CABLES TO
HDMI SWITCH FROM
WIRE ASM-A/V

- 1B2 WTR HTR-10GAL/ELEC/LP/MTRAIID
- 1BT WATER HEATER, TANKLESS
- 1DF EXT TV ENTERTAINMENT CENTER
- 265 CODES/STANDARDS-CSA/CMVSS
- 1B1 CODES/STANDARDS USA

DESCRIPTION:
WIRING INSTL-BODY, 12V

SHEET: 3 OF 9
ITEM/PART NO: 000213352 / 30186501000
REV

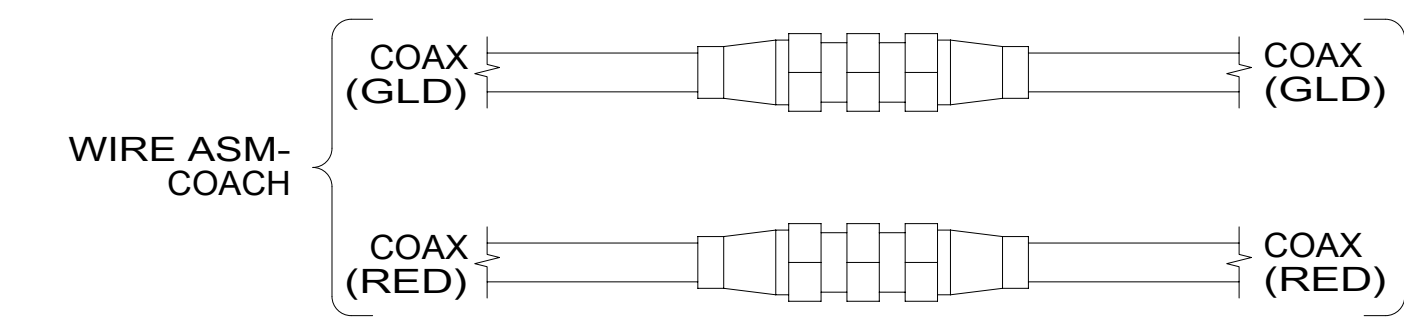

DETAIL CA

REMOTE SENSOR
171186-02-CHT
SCREW
G67-06-10T (2)

SPEAKER
124884-02-000
GRILL
151844-01-CHT
SCREW
76790-01-000 (4)

LPGD

SWITCHES
DETAIL EL

SWITCH
DETAIL EU

LCR-1

- 7 CONNECTS TO REAR OF SATELLITE PREP PLATE.
- 6 SET 'BAT TYPE' TO 'AGM2'
SET 'LBCO' TO '11VDC'
SET 'BAT AHRS' TO '400 AH'
SEE OPERATORS MANUAL FOR SETUP PROCEDURE.
- 5 SET 'GEN TYPE' TO 'GAS/LP'
SET 'SAFE TYPE' TO 'IGNITION'
SET 'SP SENSE' TO 'AFTER'
SEE OPERATORS MANUAL FOR SETUP PROCEDURE.
- 4 TOP OF LAMP SHADE/GLOBE TO BE NO LESS
THEN 150MM BELOW BOTTOM OF CABINET.
- 3 WIRE PASSES THROUGH FLOOR AT THIS POINT.

- 2. SEE WIRING DIAGRAM-BODY, 12V FOR ADDITIONAL INFORMATION.
- 1. AT MINIMUM ALL WIRES TO BE SUPPORTED AND SECURED PER
CODE REQUIREMENTS. USE CLAMP 10495 OR 10497 OR WIRE TIE
8343 OR 108046 AND SCREW G67-XX-XXX OR G56-XX-XXX AS
APPROPRIATE FOR INSTALLATION.

NOTES:

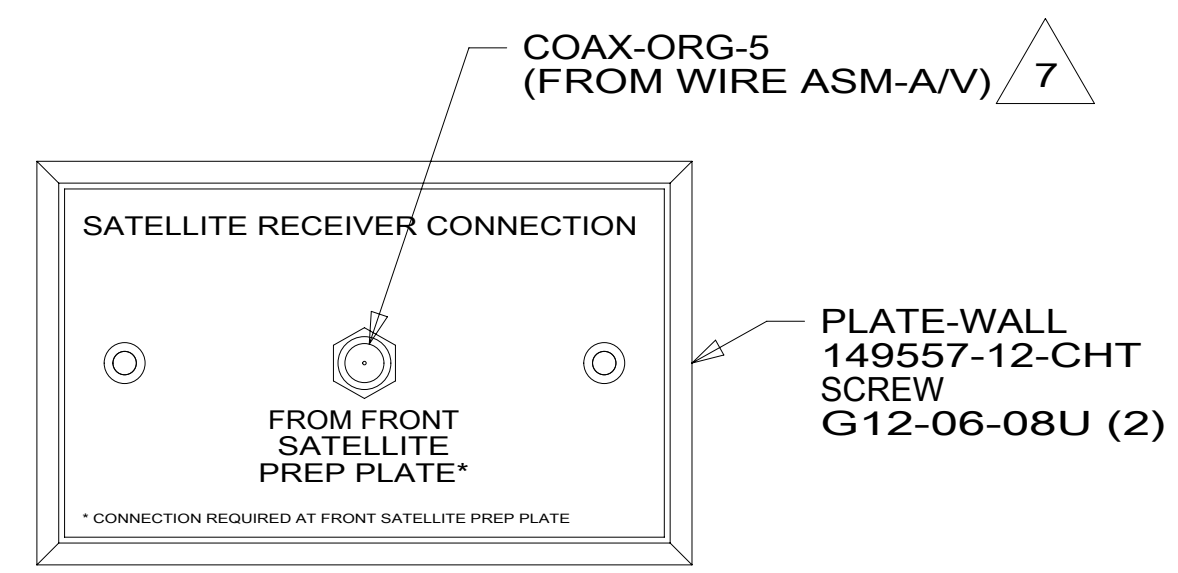

DETAIL CC

PLATE-WALL
149557-12-CHT
SCREW
G12-06-08U (2)

FOR ELECTRICAL
TORQUE
SPECIFICATIONS
SEE DWG NO.
128783-01-000

FOR ELECTRICAL
CALLOUTS
SEE DWG NO.
121339-01-000

WC,WE TO
COMPT LAMP

1B1 265

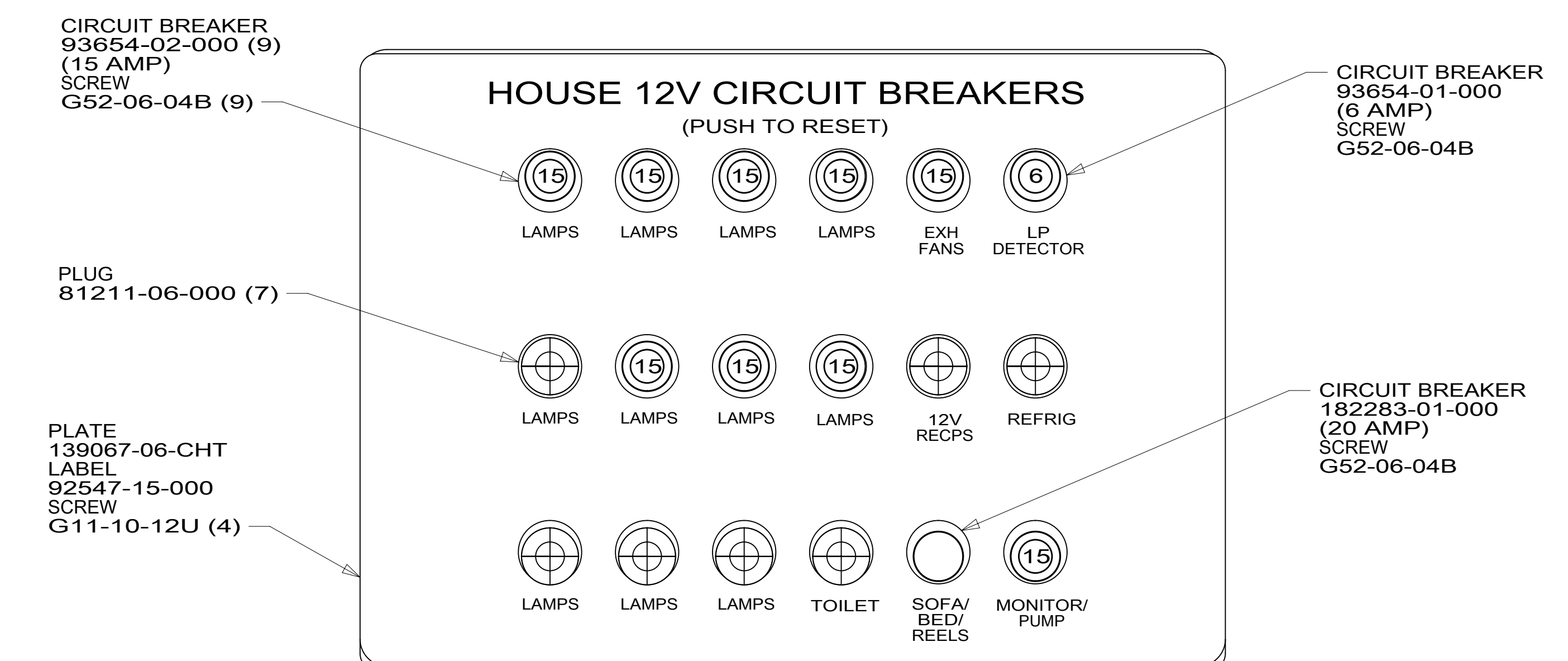
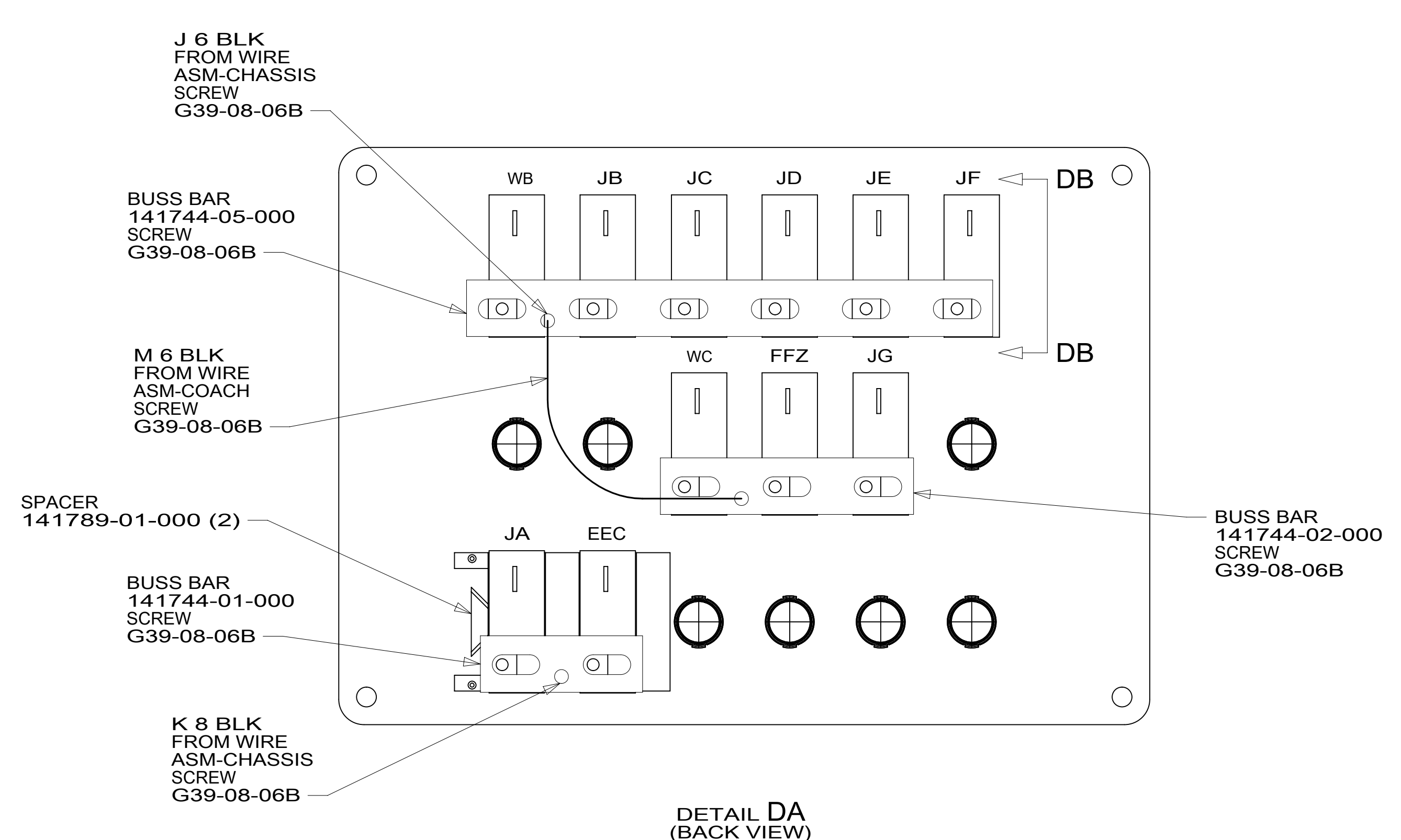
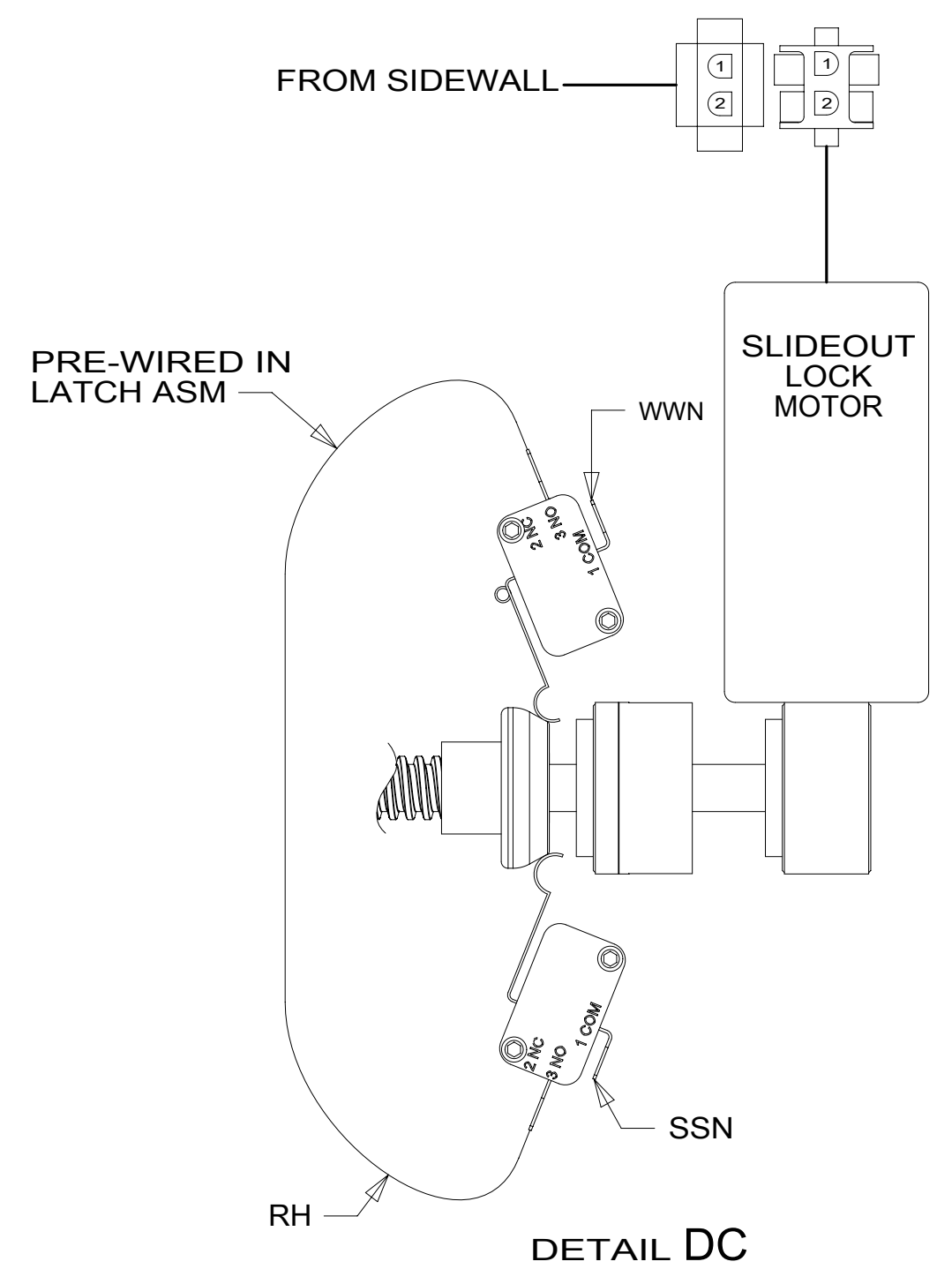
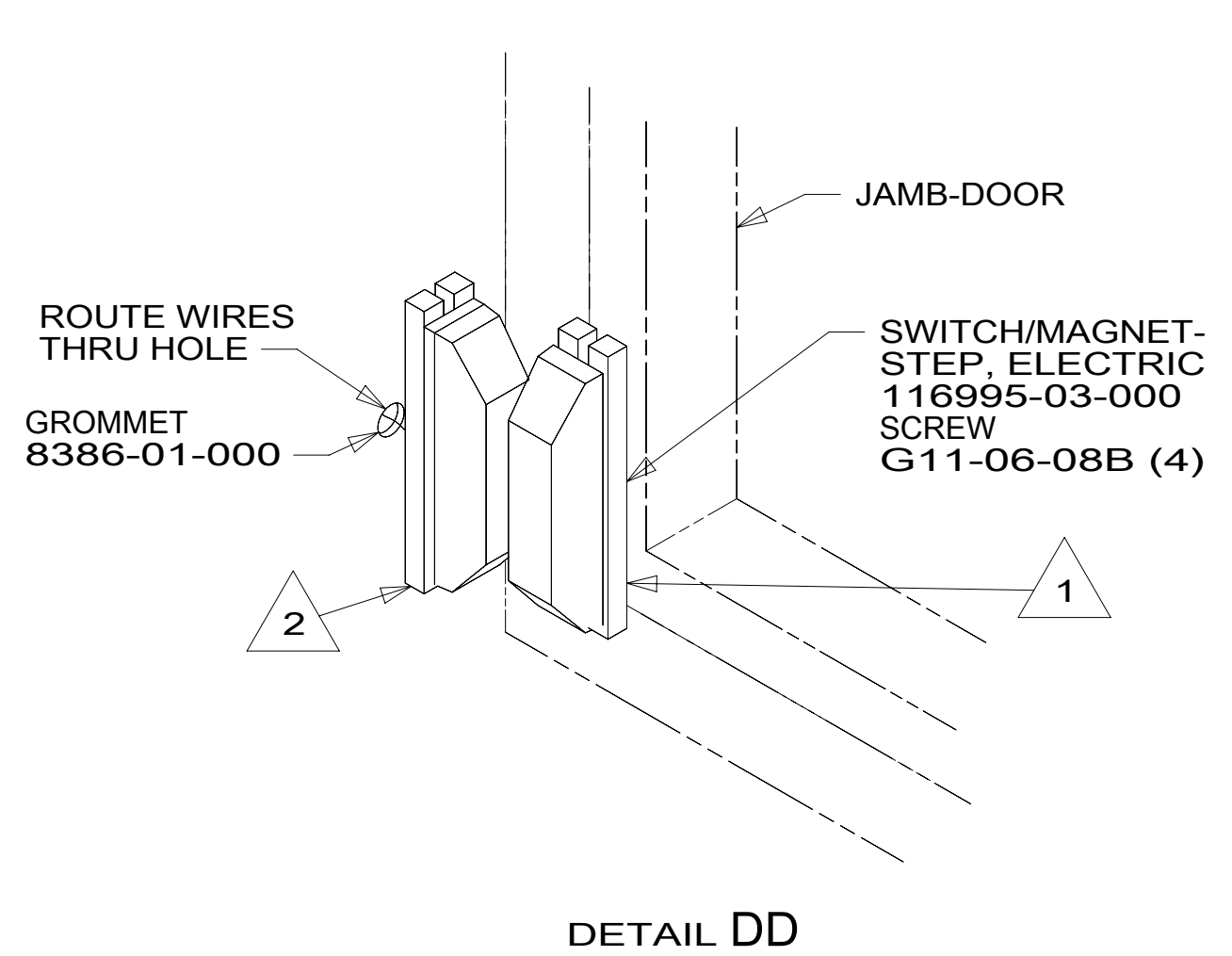
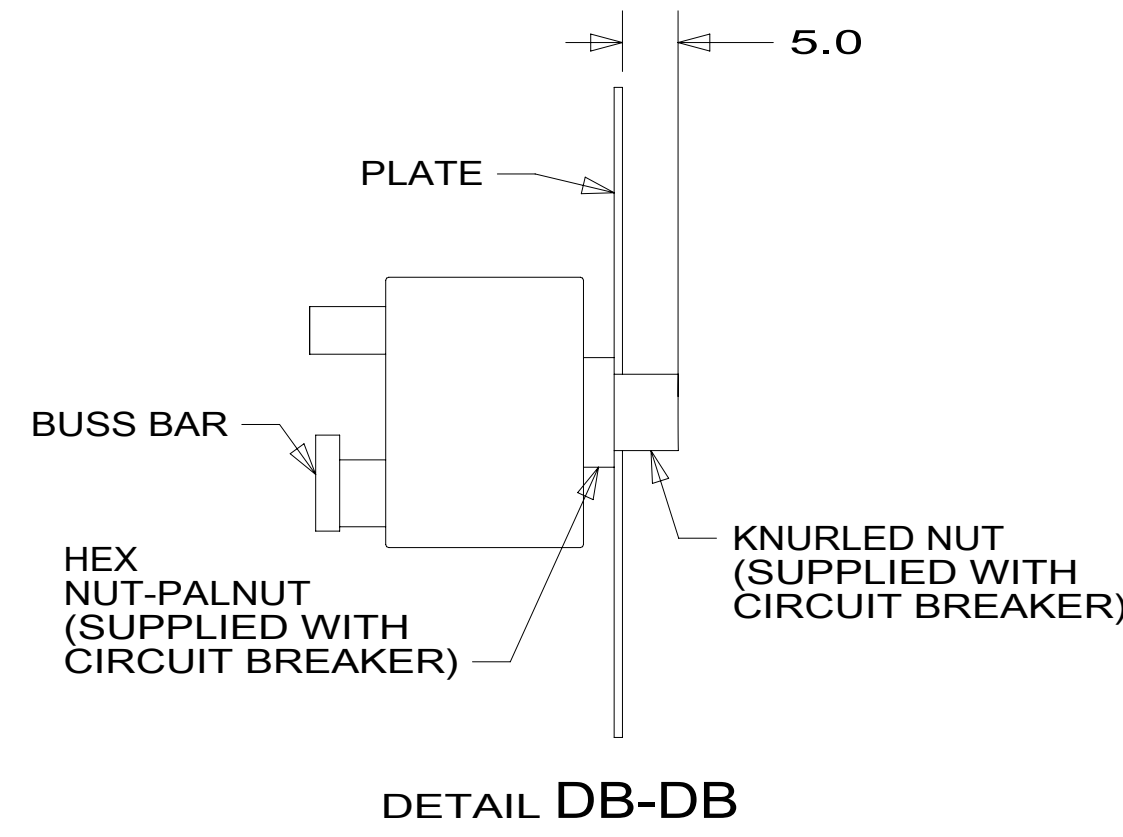

NOTES:

2 MOUNT SWITCH AND SPACER TO BLOCK ON JAMB ADJUST HEIGHT TO MATCH MAGNET.

1 MOUNT MAGNET USING PILOT HOLES IN SCREEN DOOR FRAME. MOUNT WITH MAGNET TOWARD SWITCH.

FOR ELECTRICAL TORQUE SPECIFICATIONS SEE DWG NO. 128783-01-000

FOR ELECTRICAL CALLOUTS SEE DWG NO. 121339-01-000

265 CODES/STANDARDS-CSA/CMVSS
1B1 CODES/STANDARDS USA

DESCRIPTION:		1B1 265	
WIRING INSTL-BODY, 12V			
SHEET:	ITEM/PART NO.:	REV	
4 OF 9	000213352 / 30186501000		

8 7 6 5 4 3 2 1

D
C
B
A

D
C
B
A

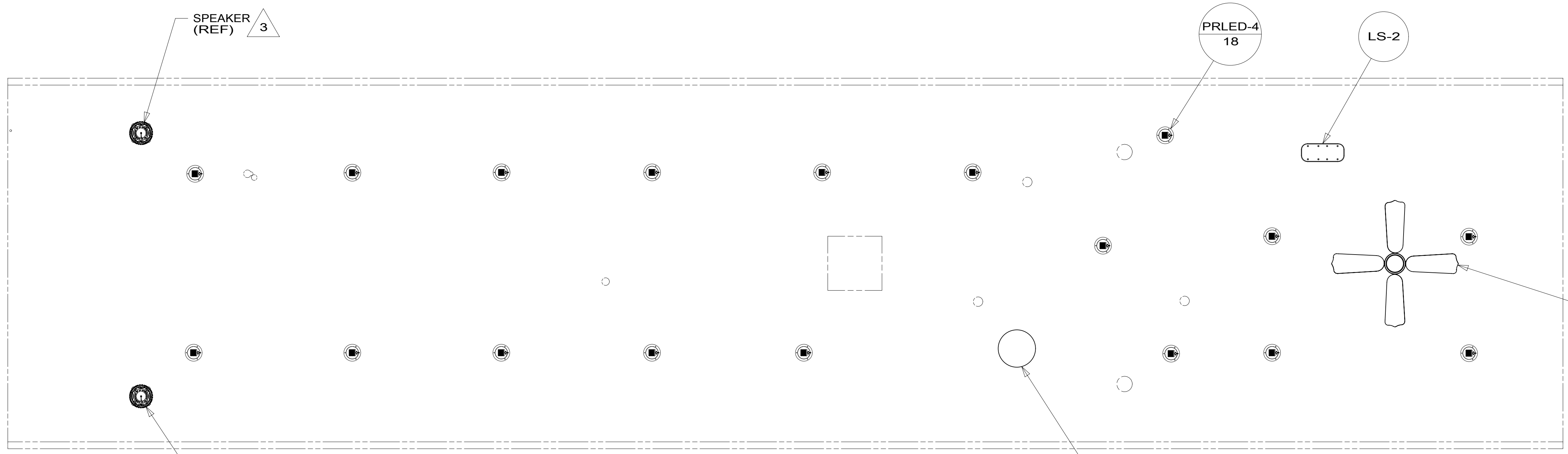

FAN-CEILING
139134-01-CHT
SCREW
G11-10-16B (3)
CONNECTOR
58028-01-000 (2)
DETAIL FA

41Y 1 2

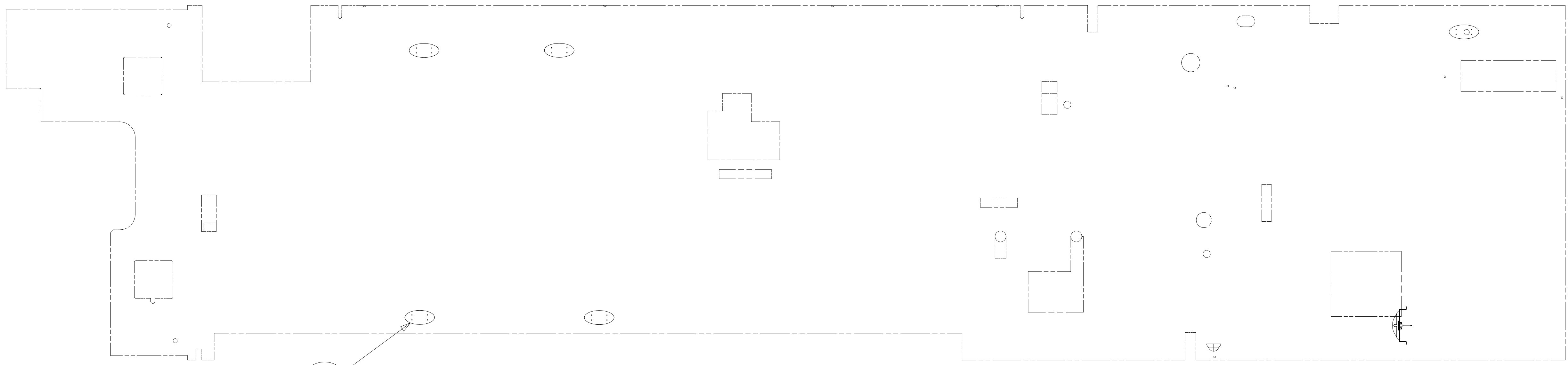

WASHER-PLASTIC
180671-02-CHT
SCREW
G11-08-08U (7)

SWITCH-FAN,
REVERSING

WIRE ASM-ROOF
RED-FFY
BLK-KKZ

CONNECT MOTOR
BLU TO SWITCH
BLU AND MOTOR
BLK TO SWITCH BLK

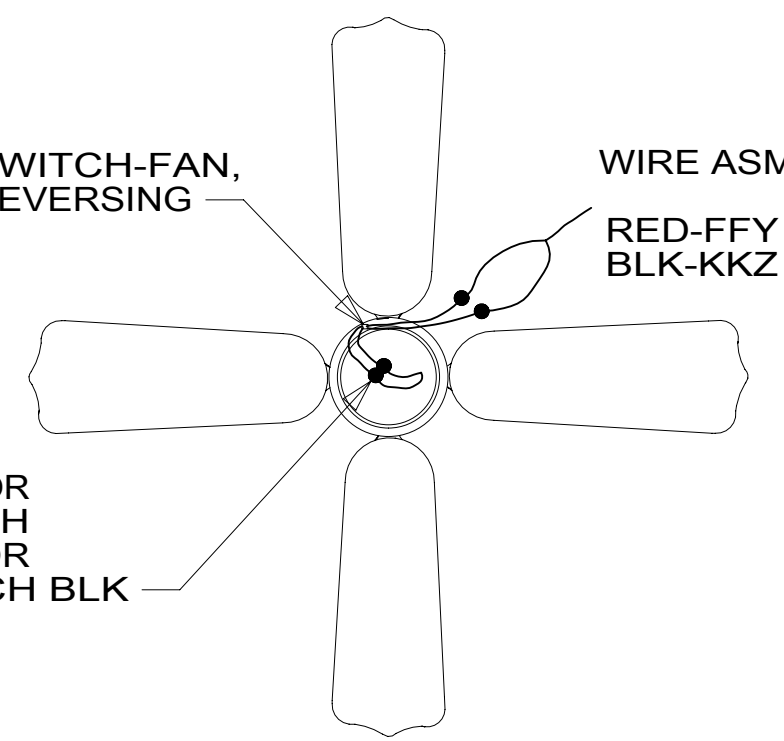

DETAIL FA

- NOTES:
- 3 SEE WIRING INSTL-FORNT END FOR ADDITIONAL INFORMATION.
 - 2 CENTER FAN OVER 25MM HOLE IN ROOF.
 - 1 APPLY LOCTITE P/N 62917-06-000 TO FAN BLADE MOUNTING NUT THREADS.

FOR ELECTRICAL
TORQUE
SPECIFICATIONS
SEE DWG NO.
128783-01-000

FOR
ELECTRICAL
CALLOUTS
SEE DWG NO.
121339-01-000

- 41Y FAN - CEILING_BEDROOM
- 265 CODES/STANDARDS-CSA/CMVSS
- 1B1 CODES/STANDARDS USA

DESCRIPTION: WIRING INSTL-BODY, 12V	
SHEET: 6 OF 9	ITEM/PART NO: 000213352 / 30186501000
REV	

8 7 6 5 4 3 2 1 11-May-2017

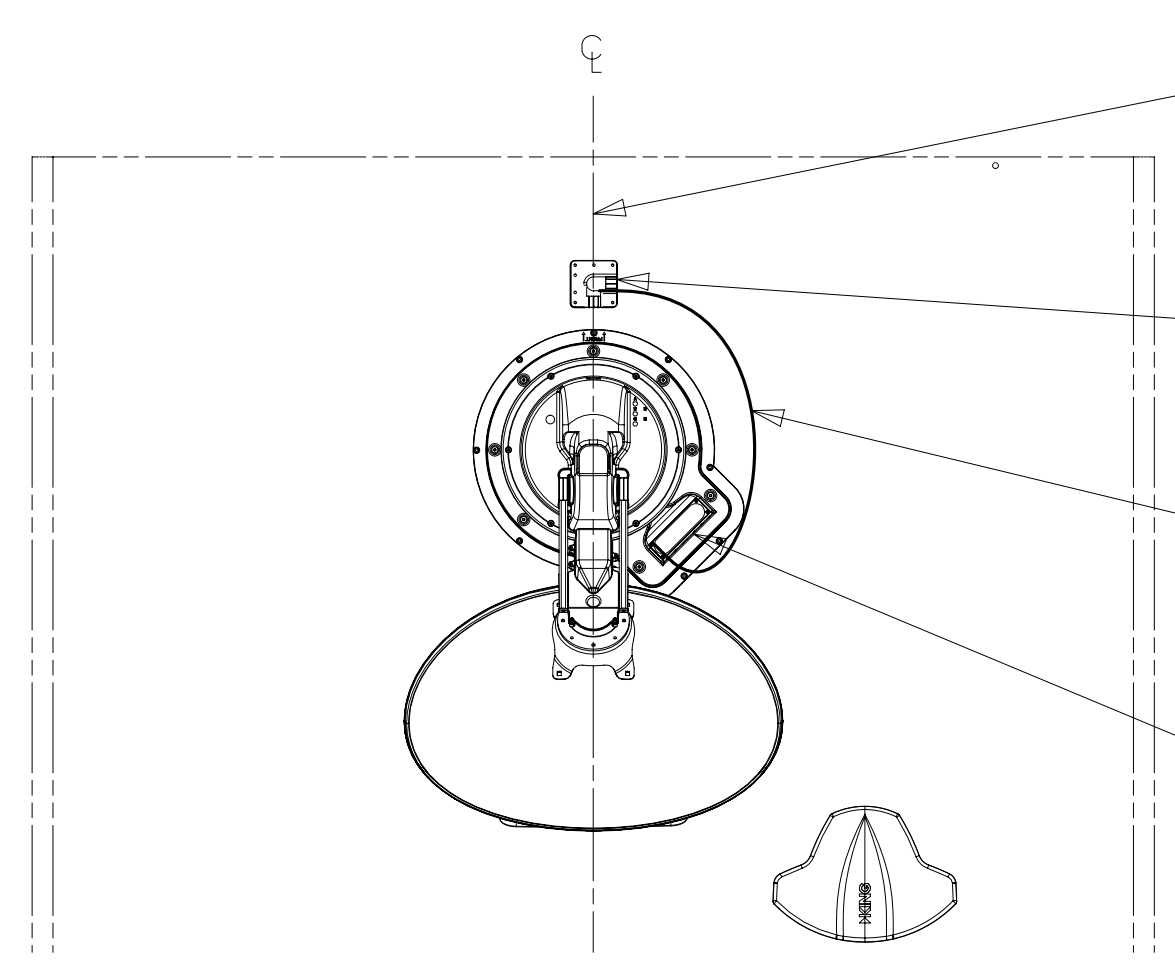

THE SATELLITE DISH AND WIRE CONNECTIONS ARE TO BE PLACED ON THE CENTERLINE OF THE MOTORHOME FACING FORWARD.

SEPARATE CABLES AND INSTALL WIRE COVER OVER HOLE IN ROOF ASM WITH CABLES EXITING ON PASSENGERS SIDE.

WHEN APPLYING ROOF SEALANT TO SATELLITE DISH, PLACE ROOF SEALANT HERE (APPROX. 75MM WIDE) AND PUSH THE CABLES INTO THE SEALANT TO STABILIZE THEM.

CONNECT CABLE ASM-COAX FROM ROOF ASM TO COAX CABLES ON SATELLITE DISH AND CONNECT 10' CABLE-DATA FROM ROOF ASM TO DATA CABLE FROM SATELLITE DISH AND PLACE ALL CONNECTIONS BACK INTO ROOF ASM.

DETAIL GB

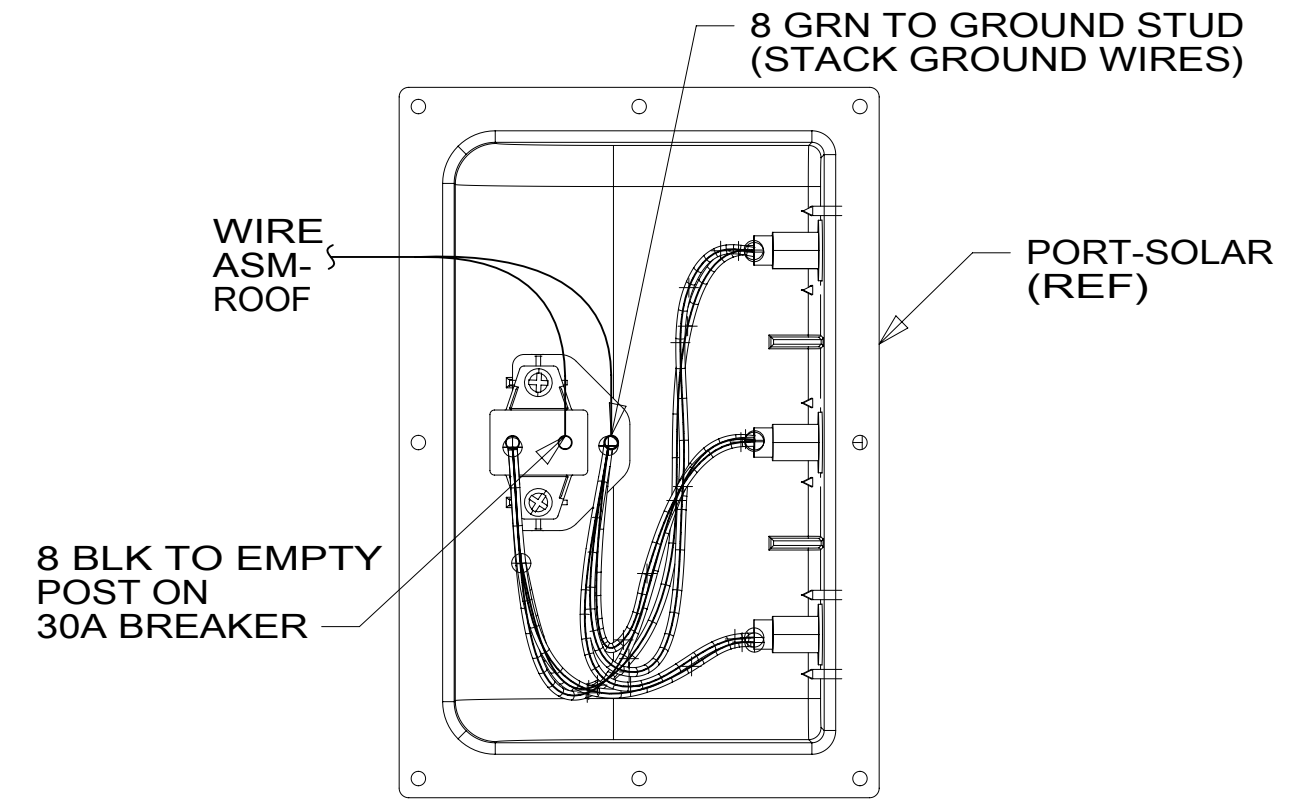

DETAIL GD 282 3AA

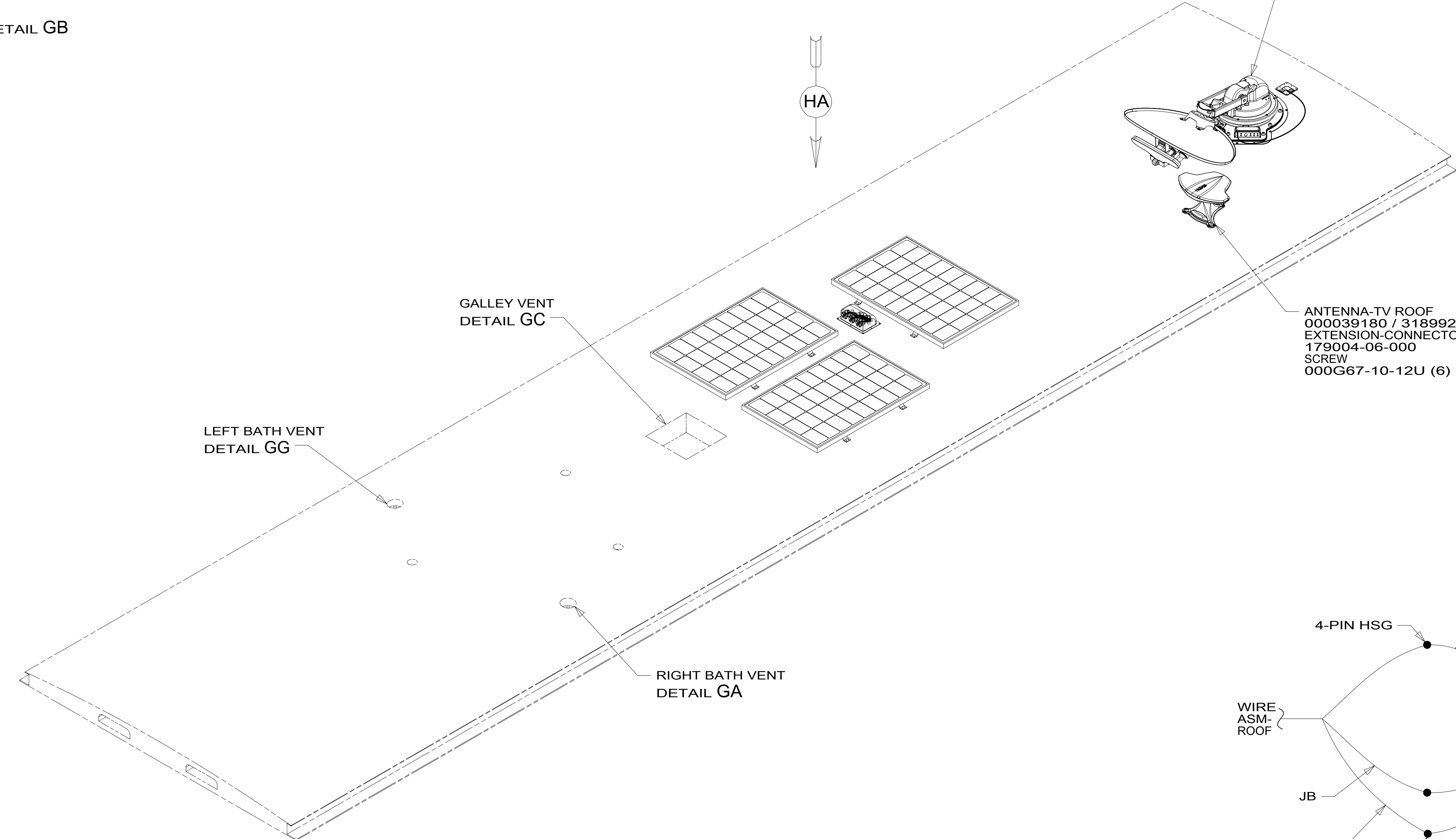

783 DA-4 1
DETAIL GB

ANTENNA-TV ROOF
000039180 / 318992-01-CHT
EXTENSION-CONNECTOR
179004-06-000
SCREW
000G67-10-12U (6)
1

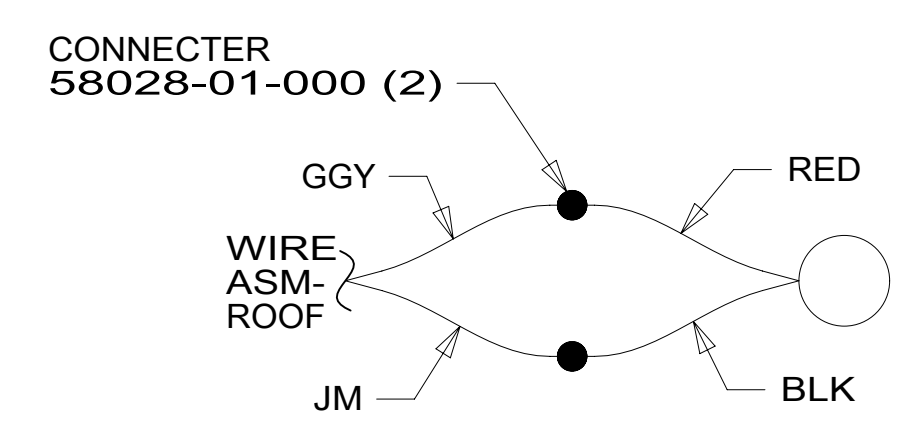

DETAIL GA

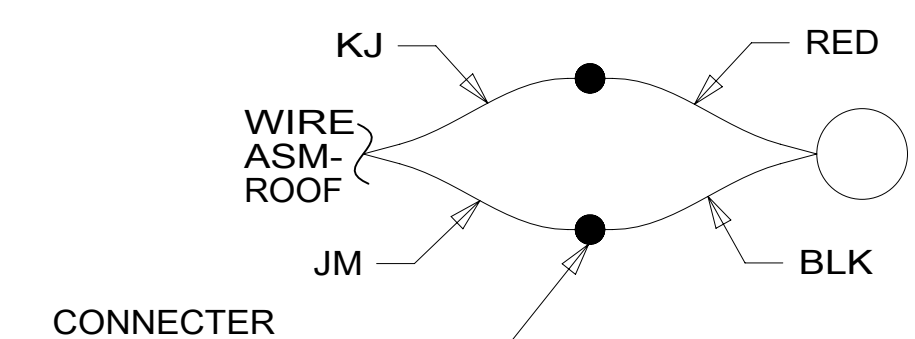

DETAIL GG

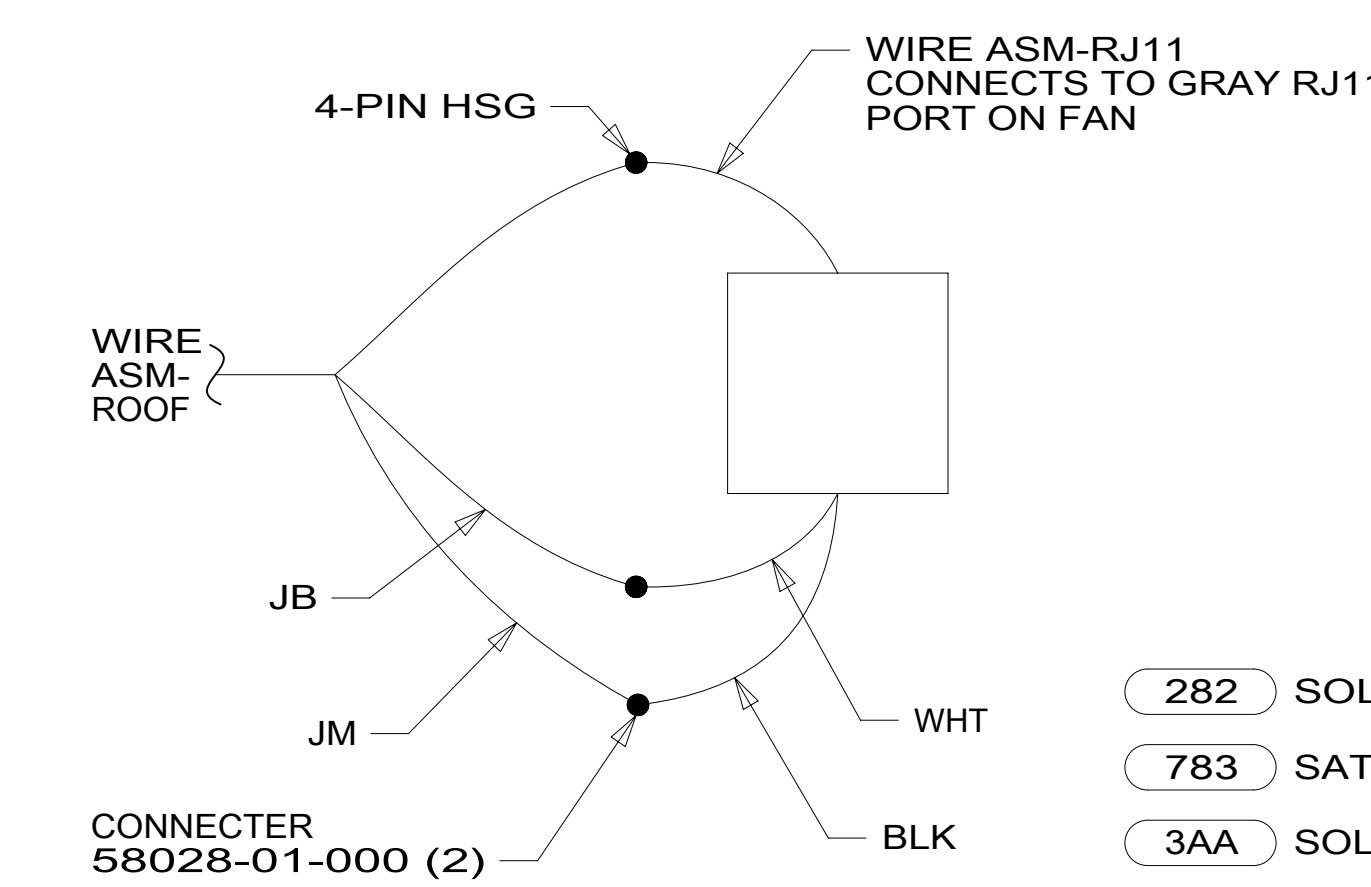

DETAIL GC

- 282 SOLAR PANEL - 100 WATT
- 783 SATELLITE HD TV SYSTEM AUTOC
- 3AA SOLAR PANEL/BATT CHARGER SYS
- 265 CODES/STANDARDS-CSA/CMVSS
- 1B1 CODES/STANDARDS USA

1 SEE ANTENNA INSTALLATION MANUAL FOR CORRECT INSTALLATION PROCEDURE.

FOR ELECTRICAL TORQUE SPECIFICATIONS SEE DWG NO. 128783-01-000

X-X FOR ELECTRICAL CALLOUTS SEE DWG NO. 121339-01-000

DESCRIPTION: WIRING INSTL-BODY, 12V	
SHEET: 7 OF 9	ITEM/PART NO.: 000213352 / 30186501000
REV 11-May-2017	

8 7 6 5 4 3 2 1

D

D

C

C

B

B

A

A

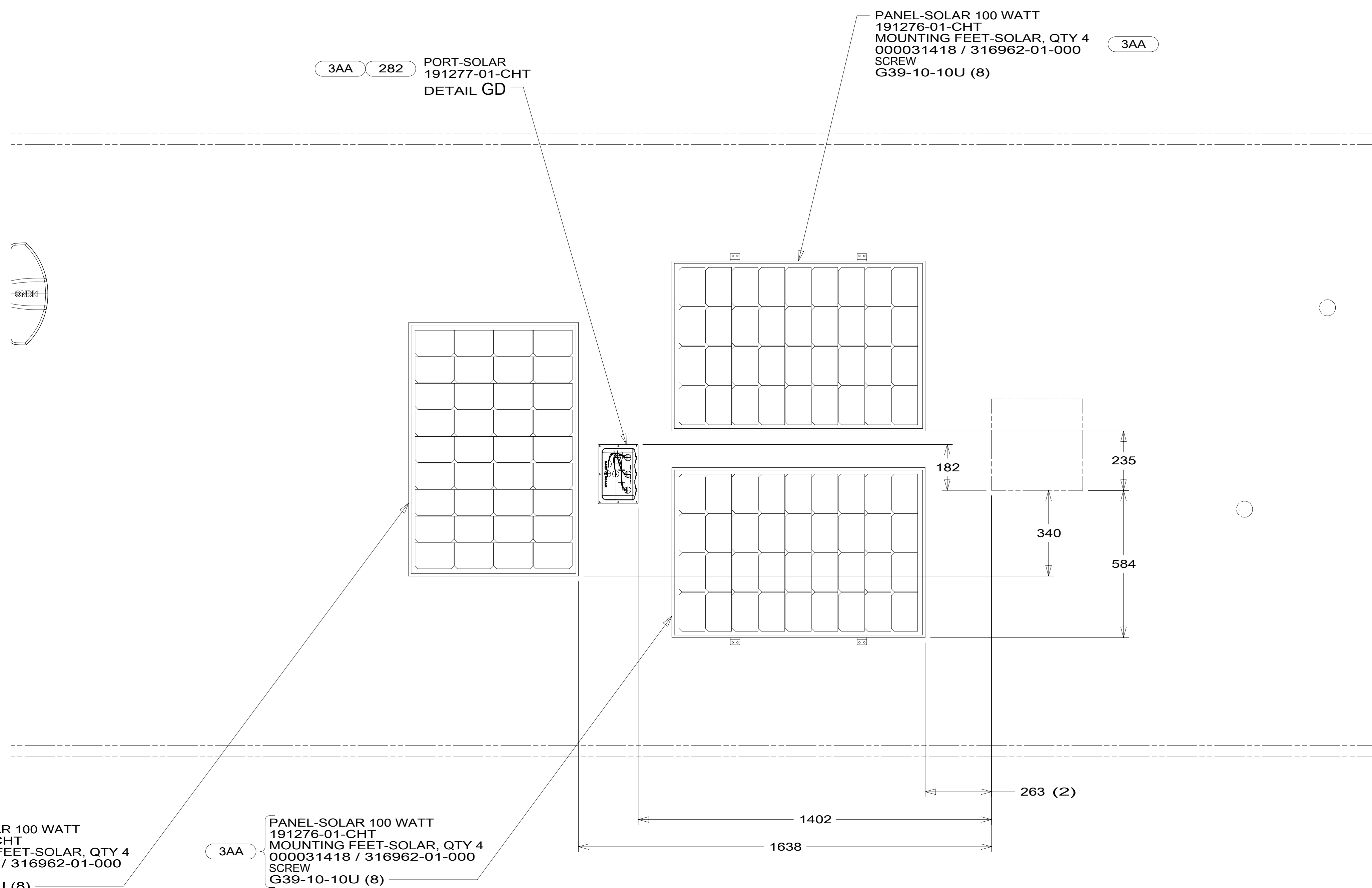

VIEW HA

- 3AA SOLAR PANEL/BATT CHARGER SYS
- 282 SOLAR PANEL - 100 WATT
- 265 CODES/STANDARDS-CSA/CMVSS
- 1B1 CODES/STANDARDS USA

FOR ELECTRICAL TORQUE SPECIFICATIONS SEE DWG NO. 128783-01-000

FOR ELECTRICAL CALLOUTS SEE DWG NO. 121339-01-000

DESCRIPTION:		
1B1 265		
WIRING INSTL-BODY, 12V		
SHEET:	ITEM/PART NO:	REV
8 OF 9	000213352 / 30186501000	

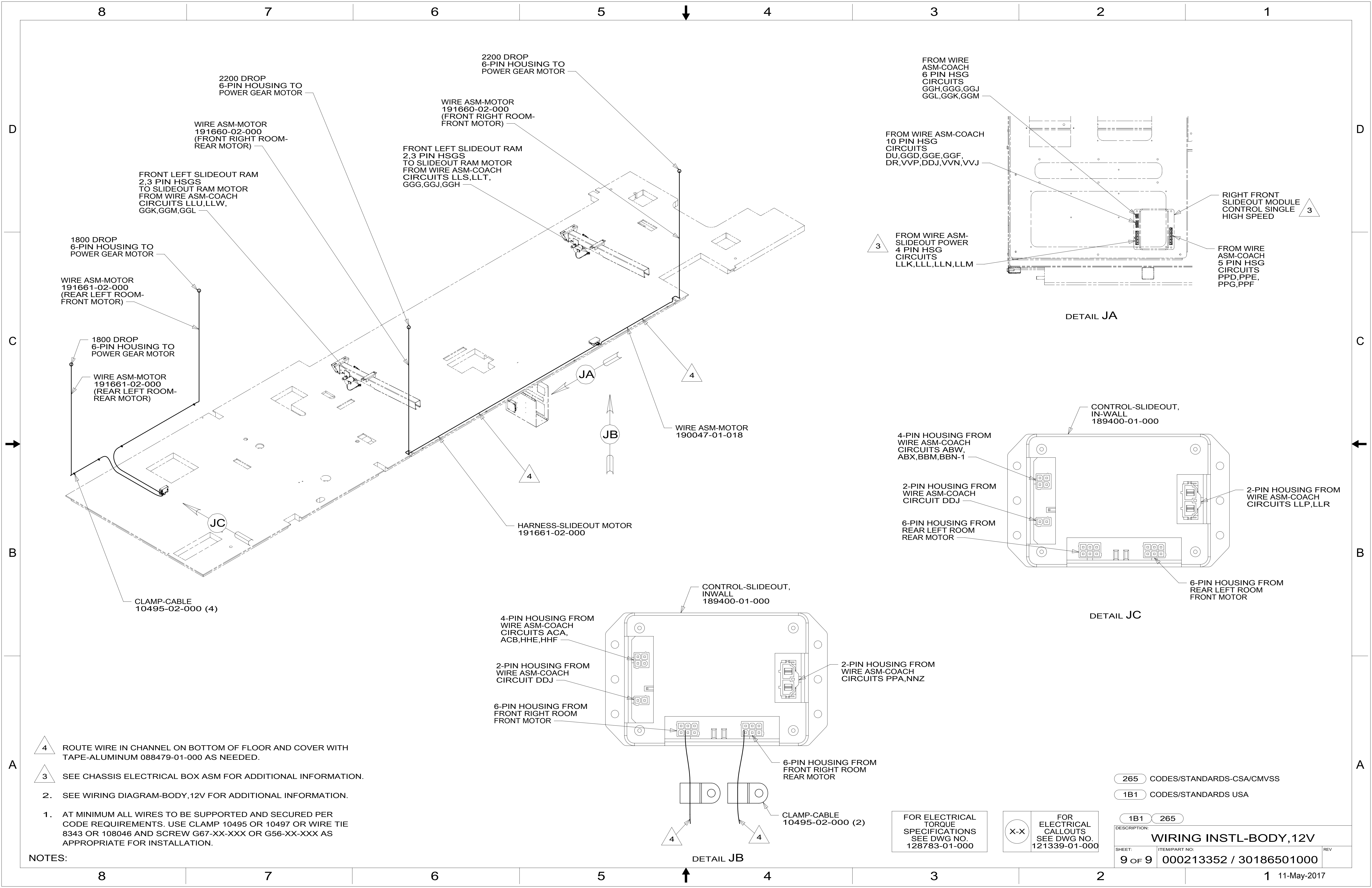

2200 DROP
6-PIN HOUSING TO
POWER GEAR MOTOR

WIRE ASM-MOTOR
191660-02-000
(FRONT RIGHT ROOM-
REAR MOTOR)

FRONT LEFT SLIDEOUT RAM
2,3 PIN HSGS
TO SLIDEOUT RAM MOTOR
FROM WIRE ASM-COACH
CIRCUITS LLU,LLW,
GGK,GGM,GGL

1800 DROP
6-PIN HOUSING TO
POWER GEAR MOTOR

WIRE ASM-MOTOR
191661-02-000
(REAR LEFT ROOM-
FRONT MOTOR)

1800 DROP
6-PIN HOUSING TO
POWER GEAR MOTOR

WIRE ASM-MOTOR
191661-02-000
(REAR LEFT ROOM-
REAR MOTOR)

2200 DROP
6-PIN HOUSING TO
POWER GEAR MOTOR

WIRE ASM-MOTOR
191660-02-000
(FRONT RIGHT ROOM-
FRONT MOTOR)

FRONT LEFT SLIDEOUT RAM
2,3 PIN HSGS
TO SLIDEOUT RAM MOTOR
FROM WIRE ASM-COACH
CIRCUITS LLS,LLT,
GGG,GGJ,GGH

FROM WIRE
ASM-COACH
6 PIN HSG
CIRCUITS
GGH,GGG,GGJ
GGL,GGK,GGM

FROM WIRE ASM-COACH
10 PIN HSG
CIRCUITS
DU,GGD,GGE,GGF,
DR,VVP,DDJ,VVN,VVJ

FROM WIRE ASM-
SLIDEOUT POWER
4 PIN HSG
CIRCUITS
LLK,LLL,LLN,LLM

RIGHT FRONT
SLIDEOUT MODULE
CONTROL SINGLE
HIGH SPEED

FROM WIRE
ASM-COACH
5 PIN HSG
CIRCUITS
PPD,PPE,
PPG,PPF

DETAIL JA

WIRE ASM-MOTOR
190047-01-018

HARNESS-SLIDEOUT MOTOR
191661-02-000

4-PIN HOUSING FROM
WIRE ASM-COACH
CIRCUITS ABW,
ABX,BBM,BBN-1

2-PIN HOUSING FROM
WIRE ASM-COACH
CIRCUIT DDJ

6-PIN HOUSING FROM
REAR LEFT ROOM
REAR MOTOR

CONTROL-SLIDEOUT,
IN-WALL
189400-01-000

2-PIN HOUSING FROM
WIRE ASM-COACH
CIRCUITS LLP,LLR

6-PIN HOUSING FROM
REAR LEFT ROOM
FRONT MOTOR

DETAIL JC

CONTROL-SLIDEOUT,
INWALL
189400-01-000

4-PIN HOUSING FROM
WIRE ASM-COACH
CIRCUITS ACA,
ACB,HHE,HHF

2-PIN HOUSING FROM
WIRE ASM-COACH
CIRCUIT DDJ

6-PIN HOUSING FROM
FRONT RIGHT ROOM
FRONT MOTOR

2-PIN HOUSING FROM
WIRE ASM-COACH
CIRCUITS PPA,NNZ

6-PIN HOUSING FROM
FRONT RIGHT ROOM
REAR MOTOR

CLAMP-CABLE
10495-02-000 (2)

DETAIL JB

- 4 ROUTE WIRE IN CHANNEL ON BOTTOM OF FLOOR AND COVER WITH TAPE-ALUMINUM 088479-01-000 AS NEEDED.
- 3 SEE CHASSIS ELECTRICAL BOX ASM FOR ADDITIONAL INFORMATION.
2. SEE WIRING DIAGRAM-BODY,12V FOR ADDITIONAL INFORMATION.
1. AT MINIMUM ALL WIRES TO BE SUPPORTED AND SECURED PER CODE REQUIREMENTS. USE CLAMP 10495 OR 10497 OR WIRE TIE 8343 OR 108046 AND SCREW G67-XX-XXX OR G56-XX-XXX AS APPROPRIATE FOR INSTALLATION.

NOTES:

265 CODES/STANDARDS-CSA/CMVSS

1B1 CODES/STANDARDS USA

1B1 265

FOR ELECTRICAL
TORQUE
SPECIFICATIONS
SEE DWG NO.
128783-01-000

FOR
ELECTRICAL
CALLOUTS
SEE DWG NO.
121339-01-000

DESCRIPTION: WIRING INSTL-BODY,12V		
SHEET: 9 OF 9	ITEM/PART NO: 000213352 / 30186501000	REV