

DRAWING NO.	FEATURE
301698-01	-----
301698-12	1B1 78J
301698-16	265 78J

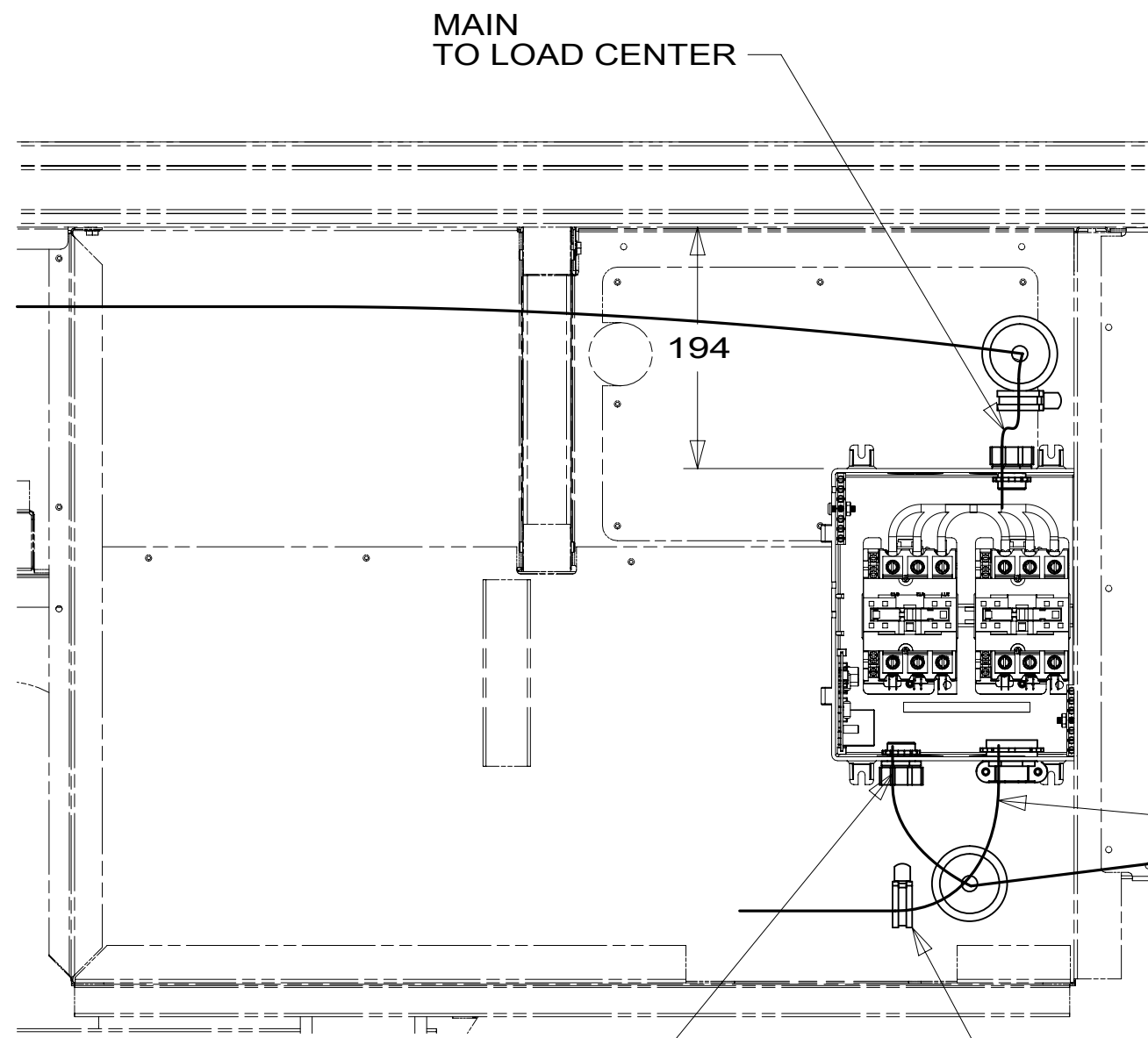

VIEW AA

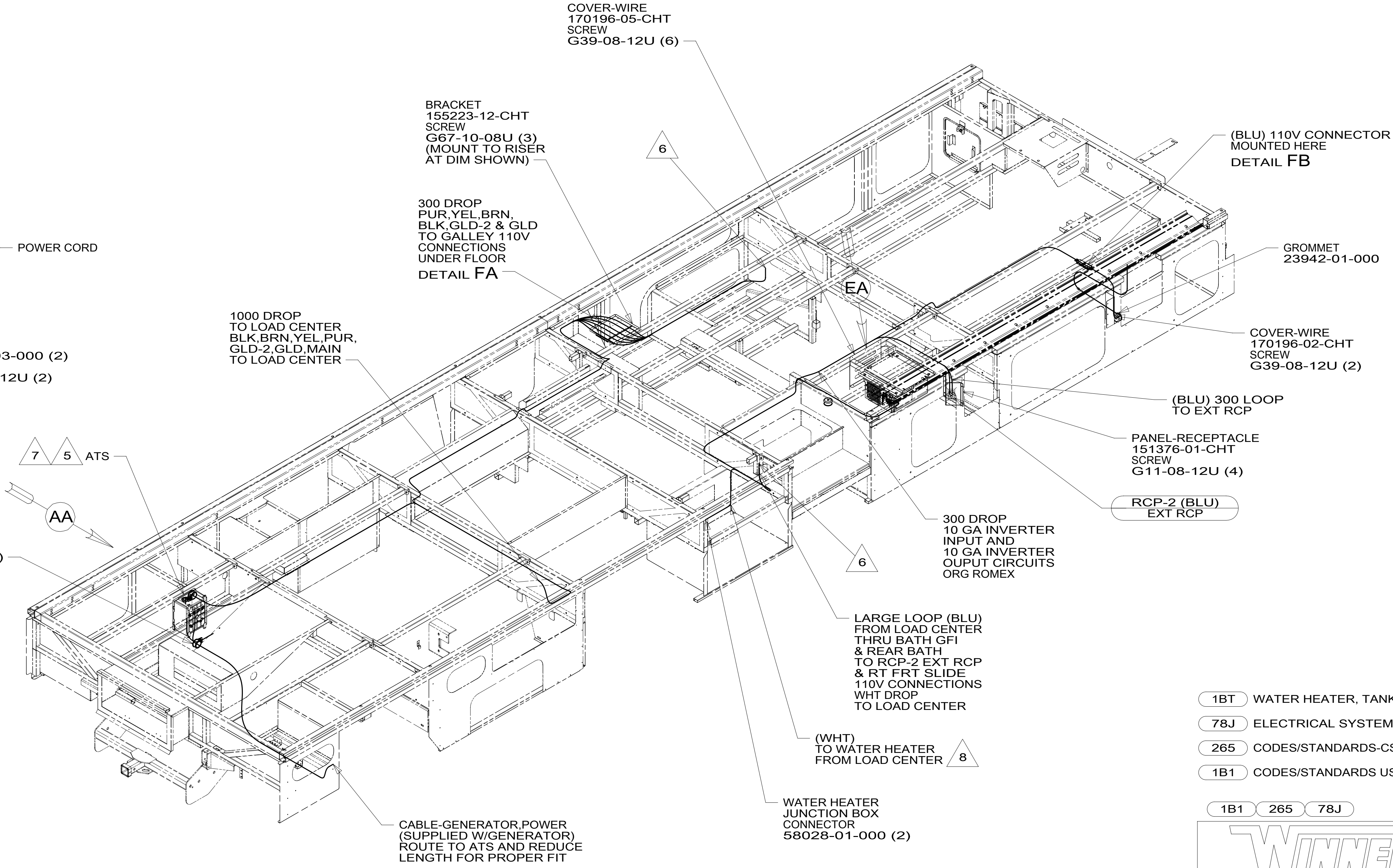

- 8 NOT USED WITH 1BT
- 7 MOUNT ATS AS HIGH AS POSSIBLE IN COMPARTMENT. ROUTE GROUND CABLE WITH GENERATOR WIRES THROUGH PANEL & CONNECT TO FRAME RAIL GROUND.
- 6 WIRE PASSES THROUGH FLOOR AT THIS POINT.
- 5 SEE LOAD CENTER/ATS ASM FOR ADDITIONAL INFORMATION.
- 4. SEE WIRING DIAGRAM-BODY, 110V FOR ADDITIONAL INFORMATION.
- 3. ALL GROUND WIRE TO BE COVERED WITH TUBING 8041-02-000.
- 2. ALL 110V WIRE TO BE CLAMPED WITH CLAMP 10497-05-000 WITHIN 200MM OF OUTLET BOXES, USE SCREW G67-10-12B.
- 1. AT MINIMUM ALL WIRES TO BE SUPPORTED AND SECURED PER CODE REQUIREMENTS. USE CLAMP 10495 OR 10497 OR WIRE TIE 8343 OR 108046 AND SCREW G67-XX-XXX OR G56-XX-XXX AS APPROPRIATE FOR INSTALLATION.

NOTES:

- 1BT WATER HEATER, TANKLESS
- 78J ELECTRICAL SYSTEM-50 AMP
- 265 CODES/STANDARDS-CSA/CMVSS
- 1B1 CODES/STANDARDS USA

WINNEBAGO
COPYRIGHT 2016 WINNEBAGO INDUSTRIES, INC.

DSNR:	ALL DIMENSIONS ARE IN MILLIMETERS
DFFR:	
UNSPECIFIED TOLERANCES:	MATERIAL:
WHOLE DIM (X) : 3	
ONE-PLACE (X.X) : 1.5	
TWO-PLACE (X.XX) : 0.50	
ANGLE : 1°	
REFER TO ES0018 FOR FASTENER TIGHTENING GUIDELINES	WEIGHT: (LBS) FIRST USED: 16 J37F
DESCRIPTION: WIRING INSTL-BODY, 110V	
SHEET: 1 OF 7	ITEM/PART NO: 000211587 / 30169801000
REF:	1 13-Dec-2016

FOR ELECTRICAL TORQUE SPECIFICATIONS SEE DWG NO. 128783-01-000

FOR ELECTRICAL CALLOUTS SEE DWG NO. 121339-01-000

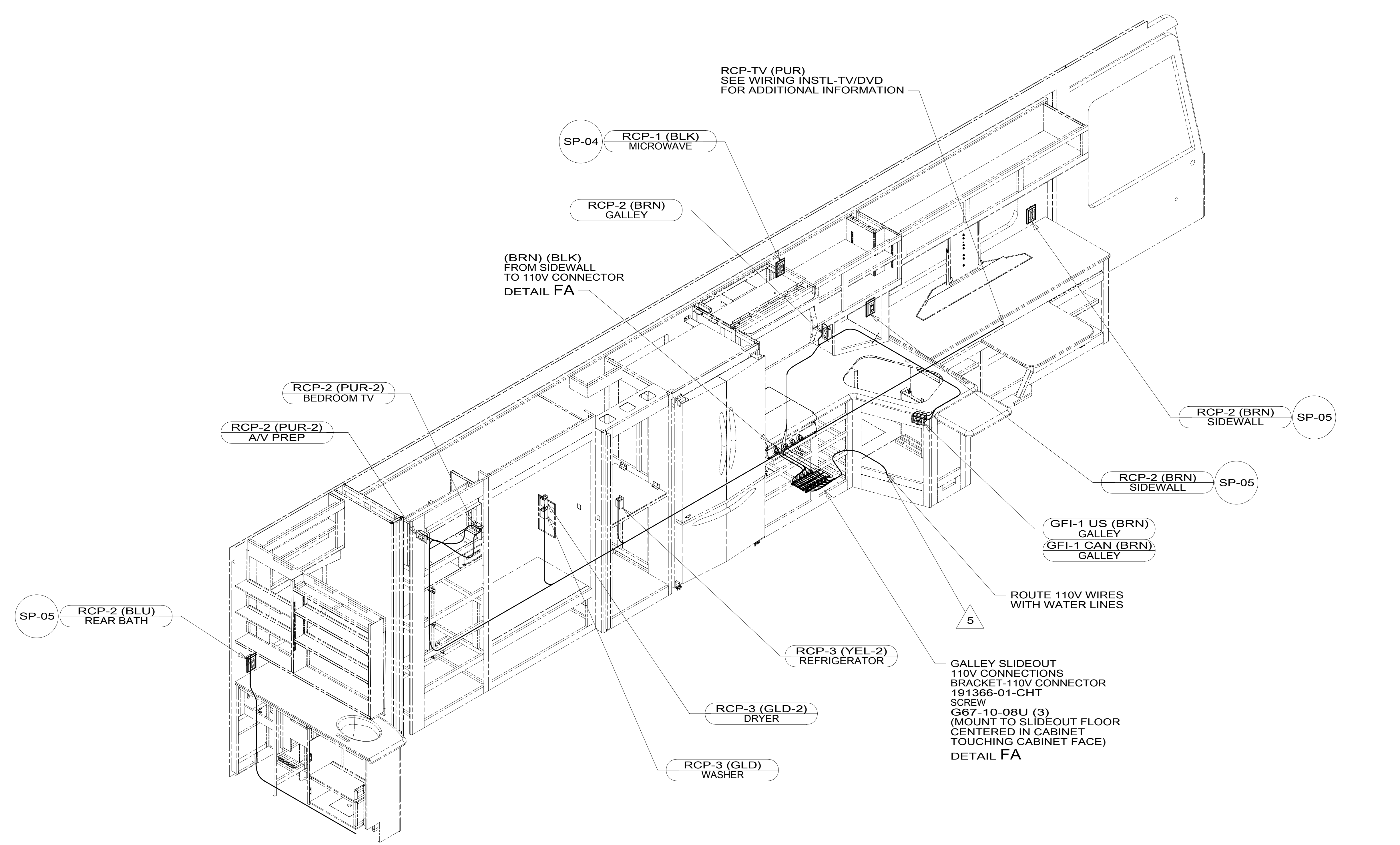

- 5 WIRE ROUTED THROUGH FLOOR AT THIS POINT.
4. SEE WIRING DIAGRAM-BODY,110V FOR ADDITIONAL INFORMATION.
3. ALL GROUND WIRE TO BE COVERED WITH TUBING 8041-02-000.
2. ALL 110V WIRE TO BE CLAMPED WITH CLAMP 10497-05-000 WITHIN 200MM OF OUTLET BOXES, USE SCREW G67-10-12B.
1. AT MINIMUM ALL WIRES TO BE SUPPORTED AND SECURED PER CODE REQUIREMENTS. USE CLAMP 10495 OR 10497 OR WIRE TIE 8343 OR 108046 AND SCREW G67-XX-XXX OR G56-XX-XXX AS APPROPRIATE FOR INSTALLATION.

NOTES:

FOR ELECTRICAL TORQUE SPECIFICATIONS SEE DWG NO. 128783-01-000

FOR ELECTRICAL CALLOUTS SEE DWG NO. 121339-01-000

- 78J ELECTRICAL SYSTEM-50 AMP
- 265 CODES/STANDARDS-CSA/CMVSS
- 1B1 CODES/STANDARDS USA

DESCRIPTION: WIRING INSTL-BODY,110V		
SHEET: 2 OF 7	ITEM/PART NO: 000211587 / 30169801000	REV

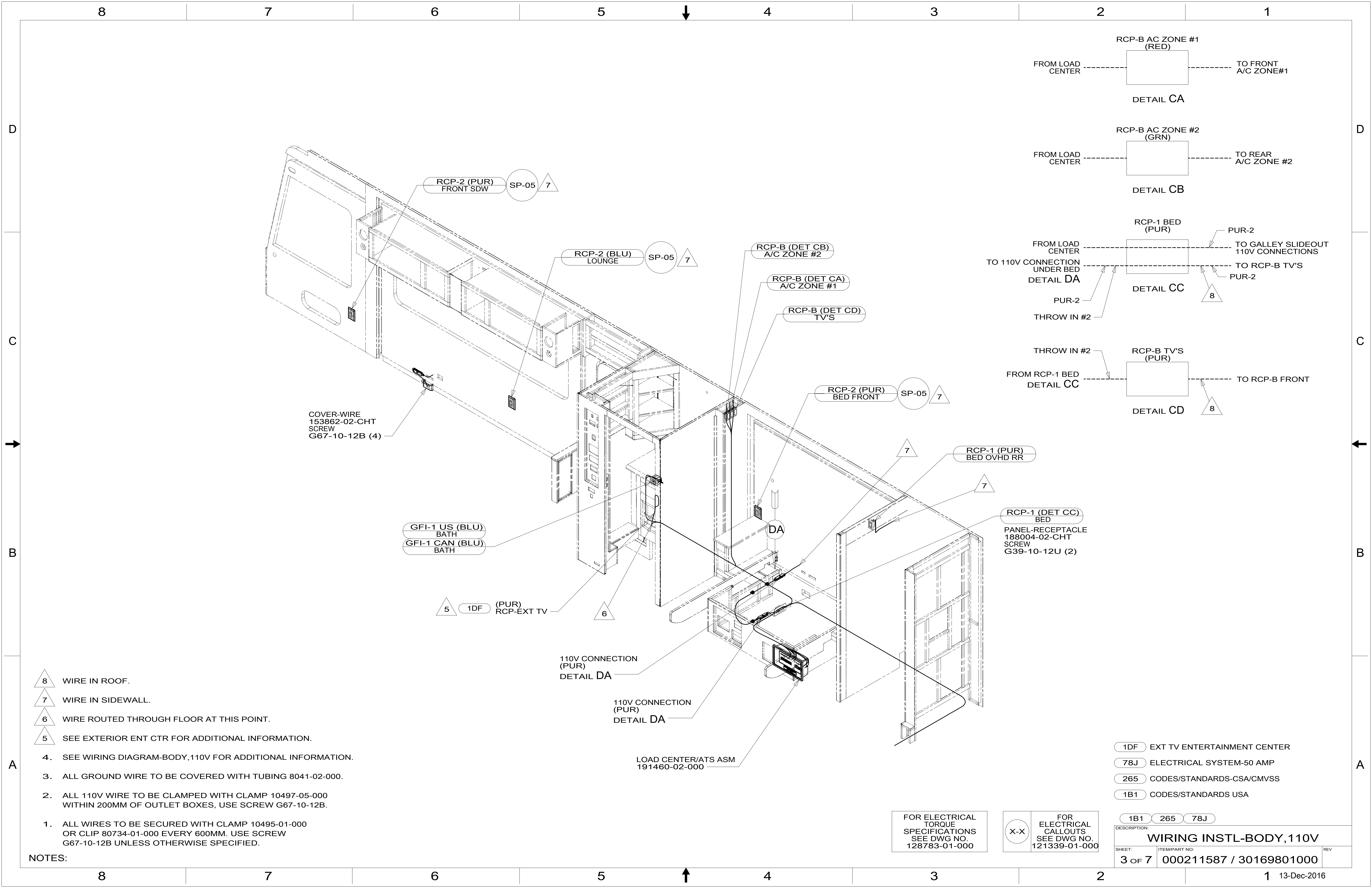

- 8 WIRE IN ROOF.
- 7 WIRE IN SIDEWALL.
- 6 WIRE ROUTED THROUGH FLOOR AT THIS POINT.
- 5 SEE EXTERIOR ENT CTR FOR ADDITIONAL INFORMATION.

- 4. SEE WIRING DIAGRAM-BODY, 110V FOR ADDITIONAL INFORMATION.
- 3. ALL GROUND WIRE TO BE COVERED WITH TUBING 8041-02-000.
- 2. ALL 110V WIRE TO BE CLAMPED WITH CLAMP 10497-05-000 WITHIN 200MM OF OUTLET BOXES, USE SCREW G67-10-12B.
- 1. ALL WIRES TO BE SECURED WITH CLAMP 10495-01-000 OR CLIP 80734-01-000 EVERY 600MM. USE SCREW G67-10-12B UNLESS OTHERWISE SPECIFIED.

NOTES:

- 1DF EXT TV ENTERTAINMENT CENTER
- 78J ELECTRICAL SYSTEM-50 AMP
- 265 CODES/STANDARDS-CSA/CMVSS
- 1B1 CODES/STANDARDS USA

FOR ELECTRICAL TORQUE SPECIFICATIONS SEE DWG NO. 128783-01-000

FOR ELECTRICAL CALLOUTS SEE DWG NO. 121339-01-000

DESCRIPTION:		
WIRING INSTL-BODY, 110V		
SHEET:	ITEM/PART NO.:	REV
3 OF 7	000211587 / 30169801000	

8 7 6 5 4 3 2 1

D
C
B
A

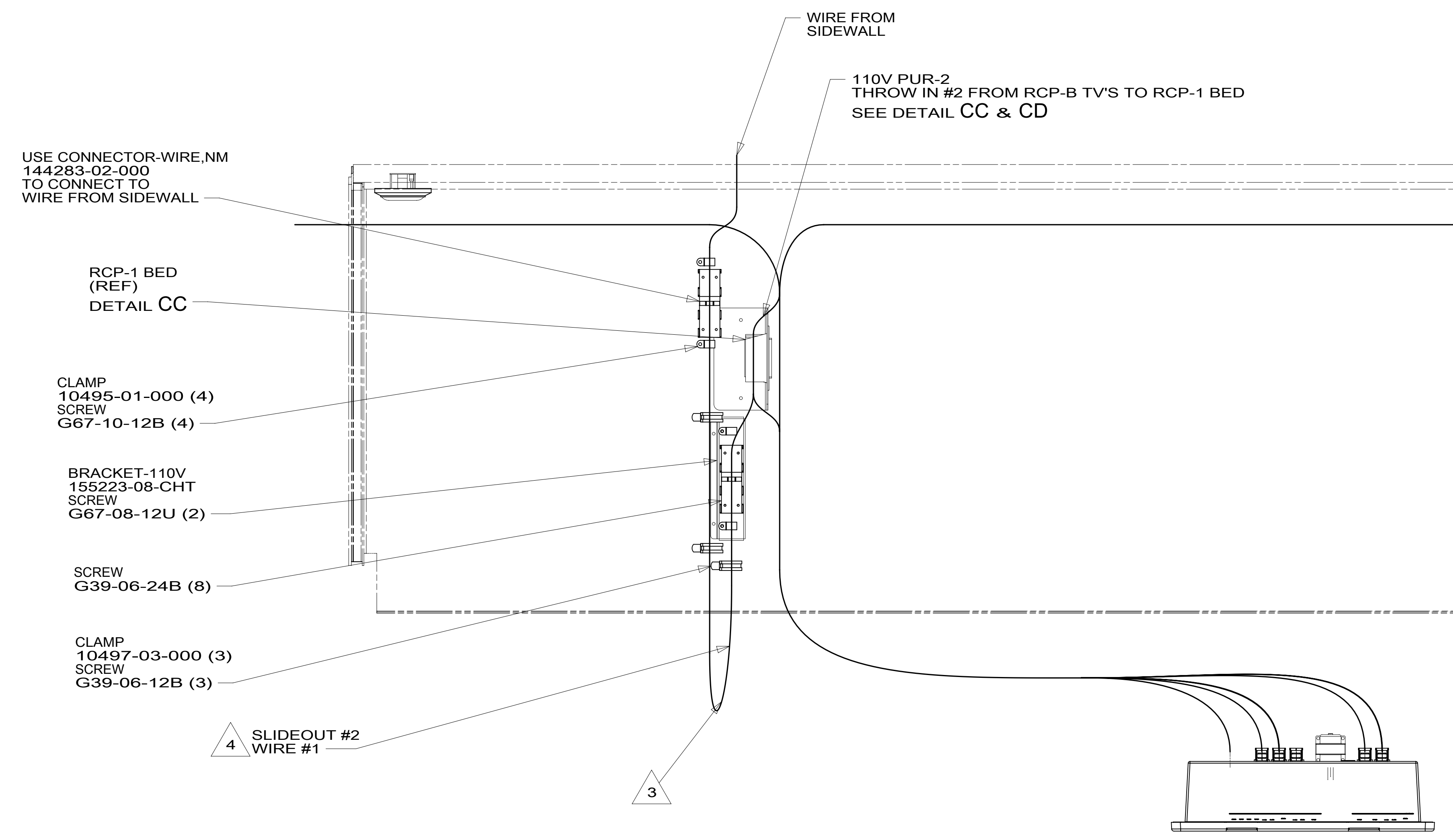

- 4 SEE LOAD CENTER/ATS ASM FOR ADDITIONAL INFORMATION.
- 3 MAKE LOOP AS SMALL AS POSSIBLE WHEN SLIDEOUT IS COMPLETELY RETRACTED.
2. RUN 12V WIRE ALONG WITH REAR SLIDEOUT WIRE.
1. WIRE MUST BE ROUTED THROUGH CLAMPS AS SHOWN.

NOTES:

FOR ELECTRICAL
TORQUE
SPECIFICATIONS
SEE DWG NO.
128783-01-000

FOR
ELECTRICAL
CALLOUTS
SEE DWG NO.
121339-01-000

- 78J ELECTRICAL SYSTEM-50 AMP
- 265 CODES/STANDARDS-CSA/CMVSS
- 1B1 CODES/STANDARDS USA

DESCRIPTION: WIRING INSTL-BODY, 110V		
1B1	265	78J
SHEET: 4 OF 7	ITEM/PART NO: 000211587 / 30169801000	REV

8 7 6 5 4 3 2 1 13-Dec-2016

8 7 6 5 4 3 2 1

D
C
B
A

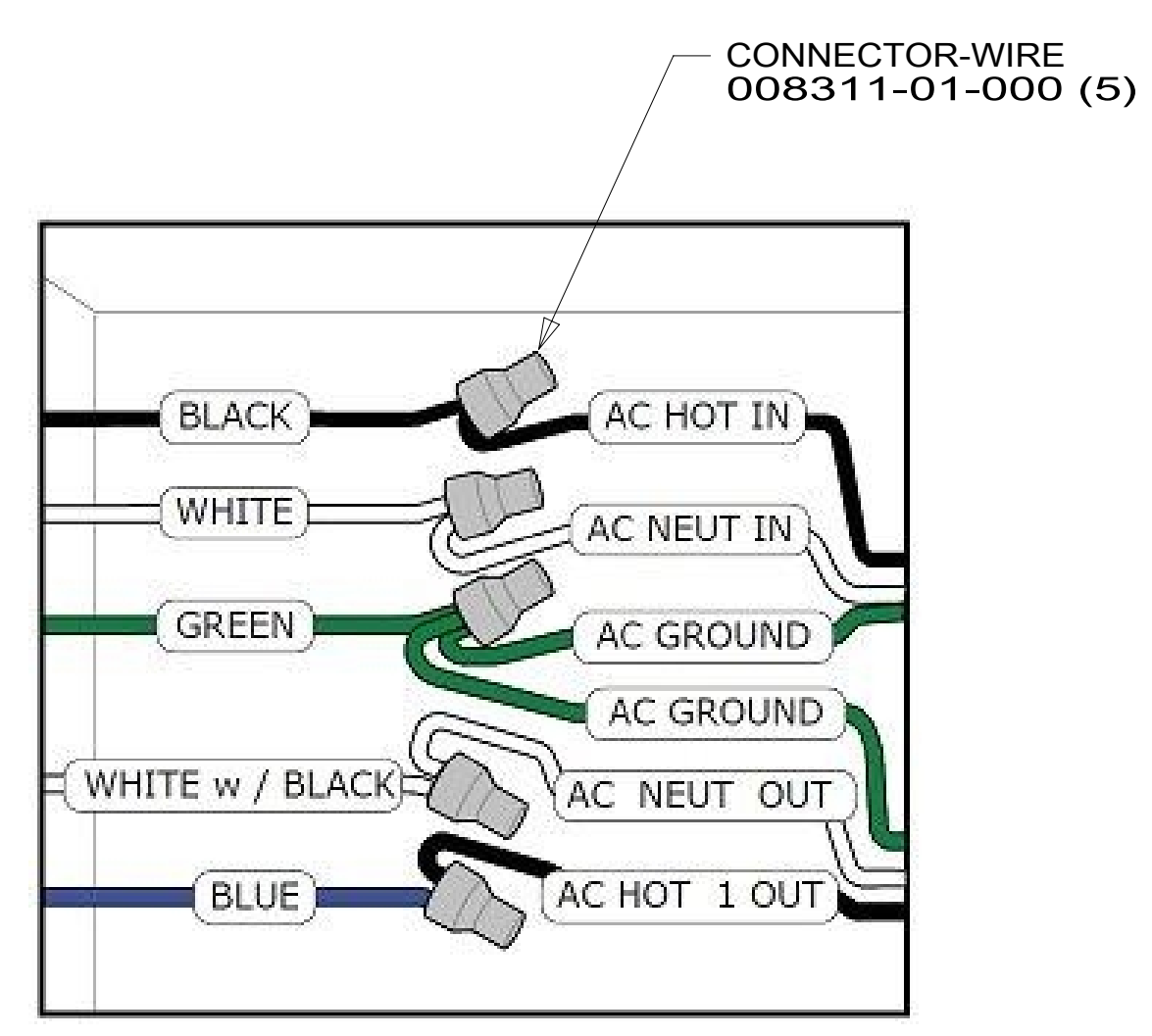
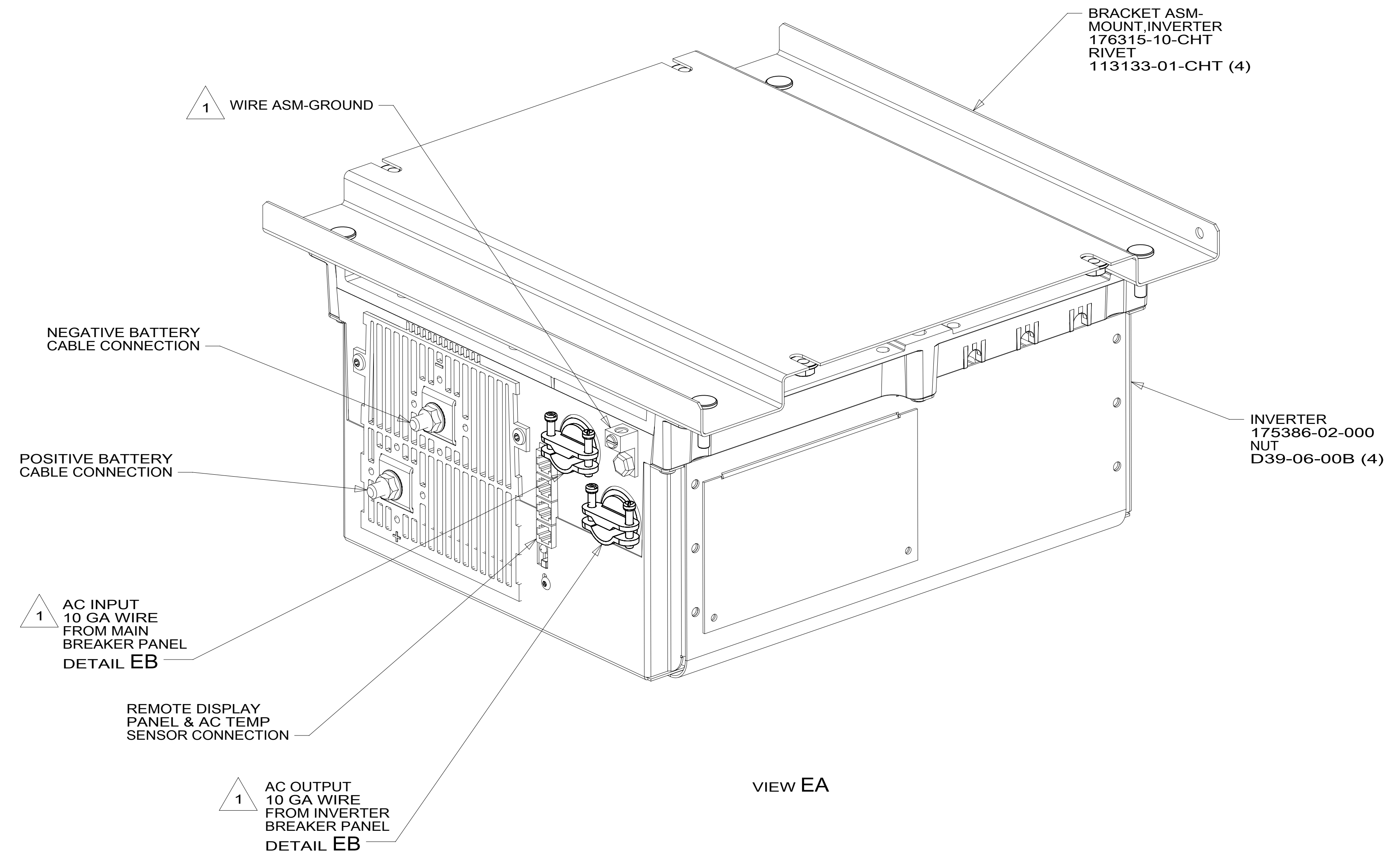

1 SEE LOAD CENTER/ATS ASM FOR ADDITIONAL INFORMATION.

NOTES:

FOR ELECTRICAL TORQUE SPECIFICATIONS SEE DWG NO. 128783-01-000

FOR ELECTRICAL CALLOUTS SEE DWG NO. 121339-01-000

- 78J ELECTRICAL SYSTEM-50 AMP
- 265 CODES/STANDARDS-CSA/CMVSS
- 1B1 CODES/STANDARDS USA

DESCRIPTION: WIRING INSTL-BODY, 110V		
1B1	265	78J
SHEET: 5 OF 7	ITEM/PART NO: 000211587 / 30169801000	REV

8 7 6 5 4 3 2 1 13-Dec-2016

8 7 6 5 4 3 2 1

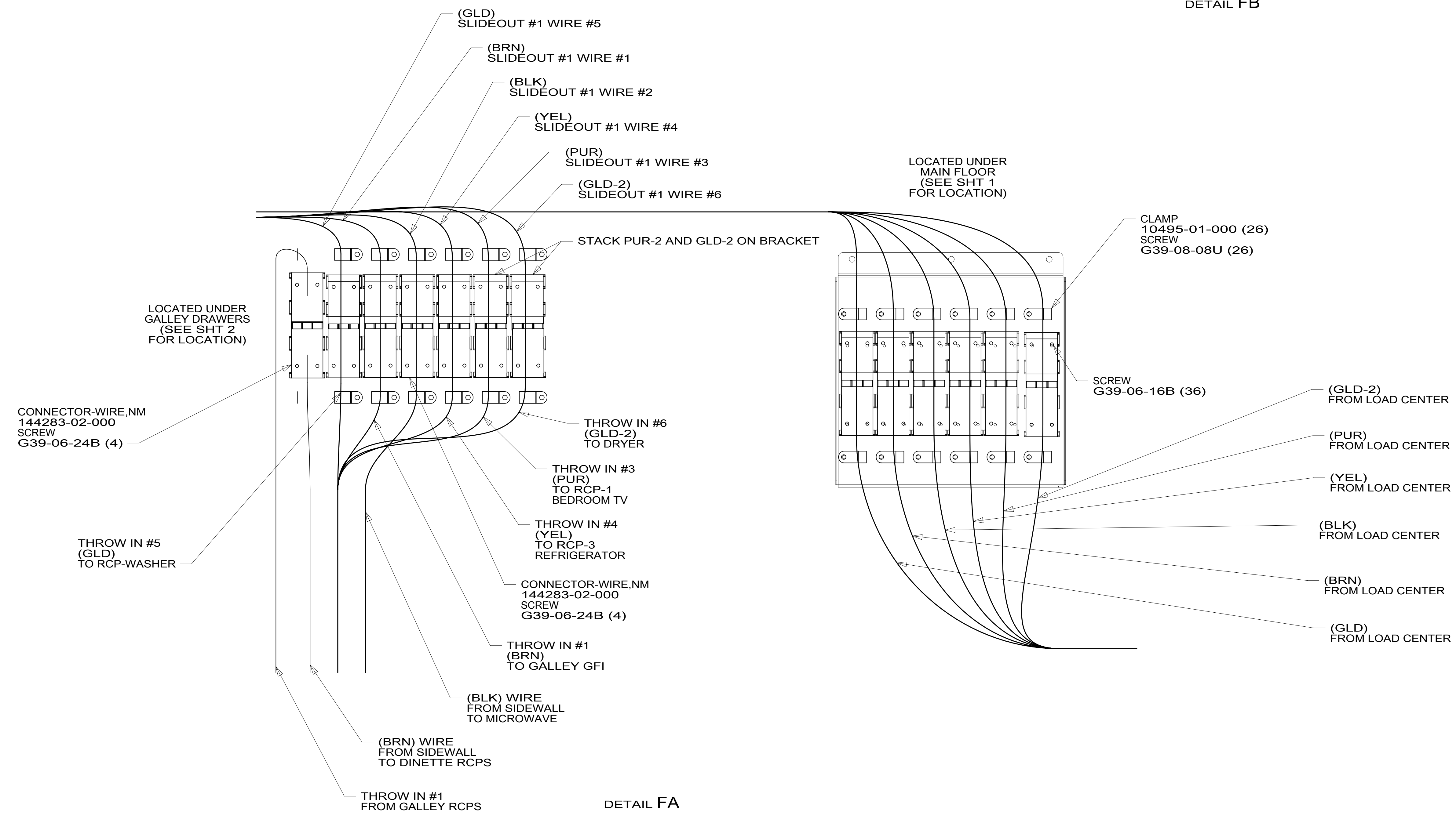
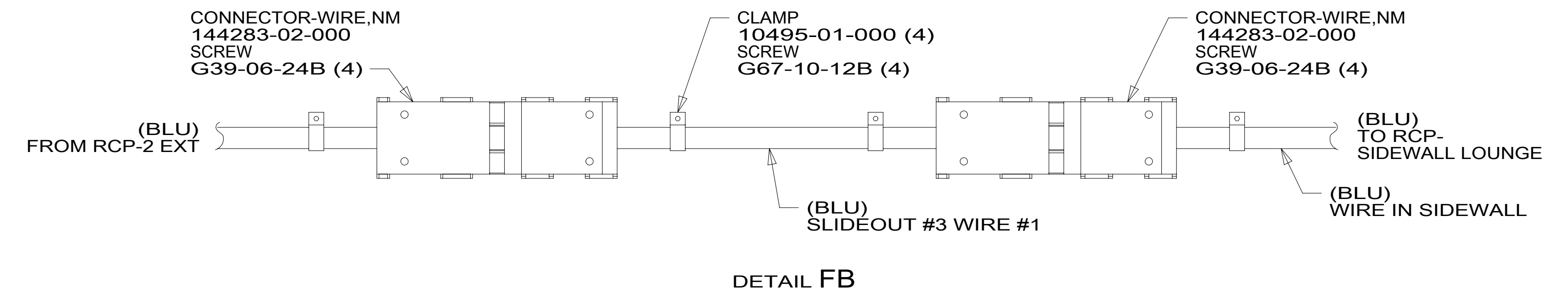

- 78J ELECTRICAL SYSTEM-50 AMP
- 265 CODES/STANDARDS-CSA/CMVSS
- 1B1 CODES/STANDARDS USA

FOR ELECTRICAL TORQUE SPECIFICATIONS SEE DWG NO. 128783-01-000

FOR ELECTRICAL CALLOUTS SEE DWG NO. 121339-01-000

DESCRIPTION:		
1B1 265 78J		
WIRING INSTL-BODY, 110V		
SHEET:	ITEM/PART NO.:	REV
6 OF 7	000211587 / 30169801000	

8 7 6 5 4 3 2 1 13-Dec-2016

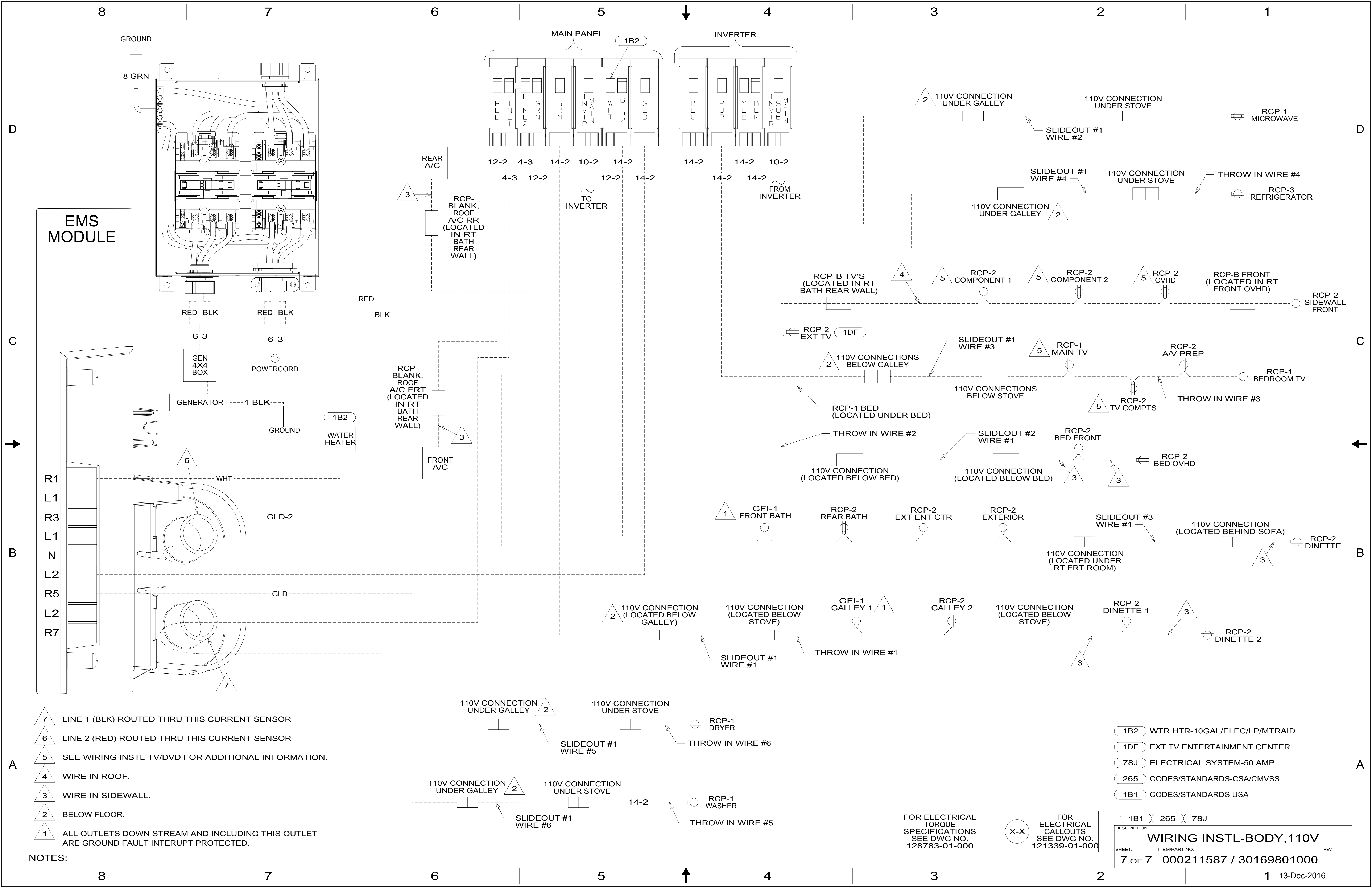

EMS MODULE

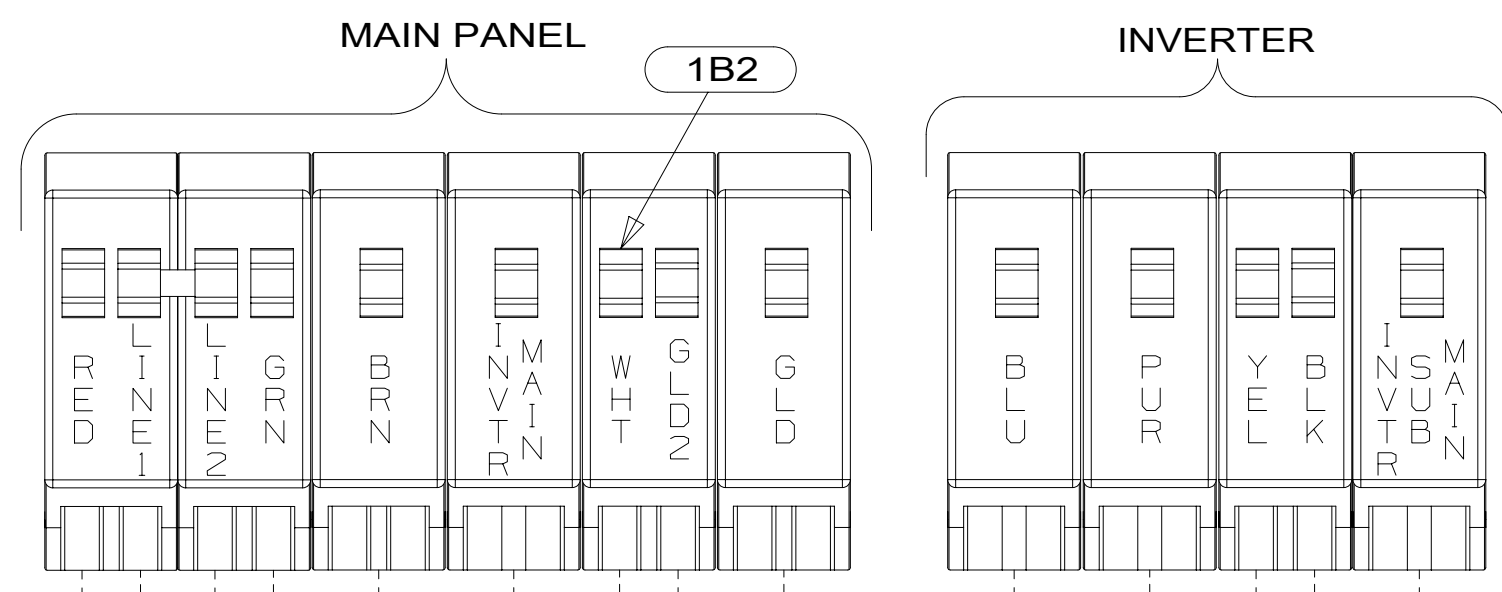

- NOTES:**
- 7 LINE 1 (BLK) ROUTED THRU THIS CURRENT SENSOR
 - 6 LINE 2 (RED) ROUTED THRU THIS CURRENT SENSOR
 - 5 SEE WIRING INSTL-TV/DVD FOR ADDITIONAL INFORMATION.
 - 4 WIRE IN ROOF.
 - 3 WIRE IN SIDEWALL.
 - 2 BELOW FLOOR.
 - 1 ALL OUTLETS DOWN STREAM AND INCLUDING THIS OUTLET ARE GROUND FAULT INTERRUPT PROTECTED.

- 1B2 WTR HTR-10GAL/ELEC/LP/MTR/DAID
- 1DF EXT TV ENTERTAINMENT CENTER
- 78J ELECTRICAL SYSTEM-50 AMP
- 265 CODES/STANDARDS-CSA/CMVSS
- 1B1 CODES/STANDARDS USA

FOR ELECTRICAL TORQUE SPECIFICATIONS SEE DWG NO. 128783-01-000

FOR ELECTRICAL CALLOUTS SEE DWG NO. 121339-01-000

DESCRIPTION: WIRING INSTL-BODY, 110V		
SHEET: 7 OF 7	ITEM/PART NO: 000211587 / 30169801000	REV
13-Dec-2016		