

8 7 6 5 4 3 2 1

BB

LAMP-MARKER, W RED LENS  
193802-04-000  
SCREW  
G11-08-12U (EXT)(2)

LAMP ASM-PORCH  
184120-01-CHT  
SCREW  
G68-06-10U (2)  
CONNECTOR  
58028-01-000 (2)

BA

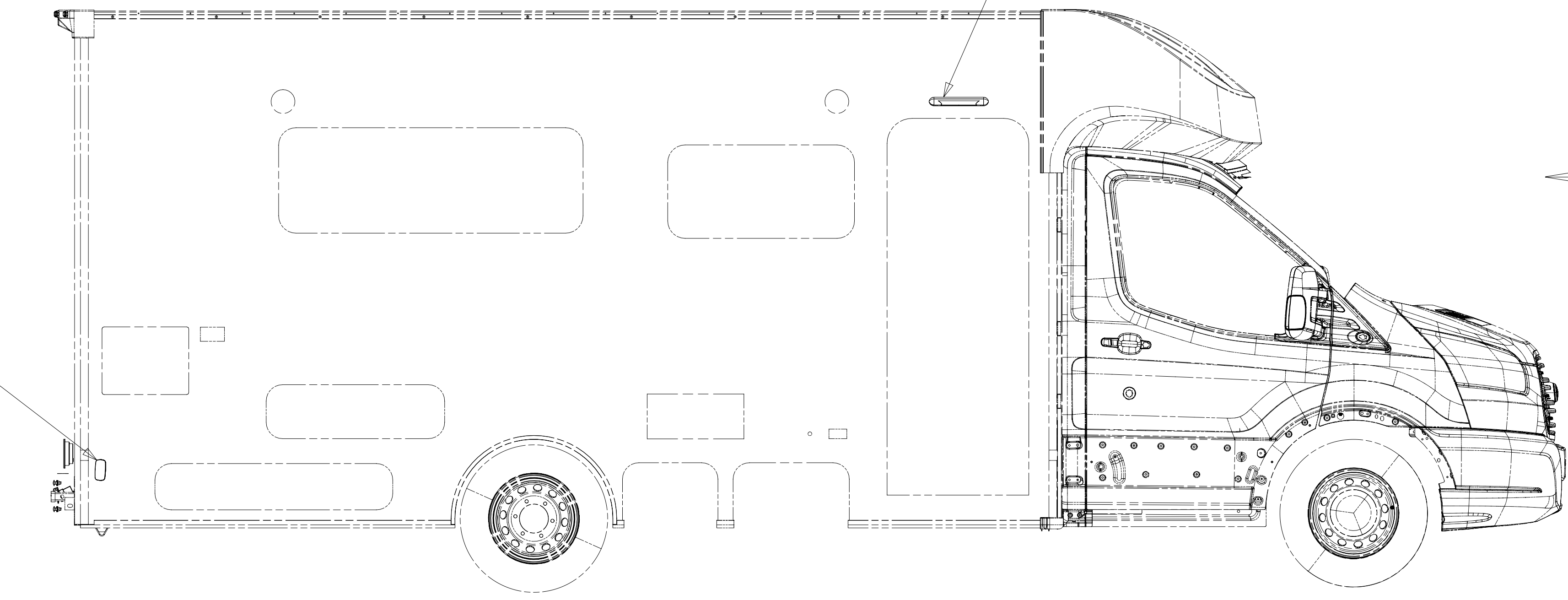

LAMP-MARKER, W RED LENS  
193802-04-000  
SCREW  
G11-08-12U (EXT)(2)

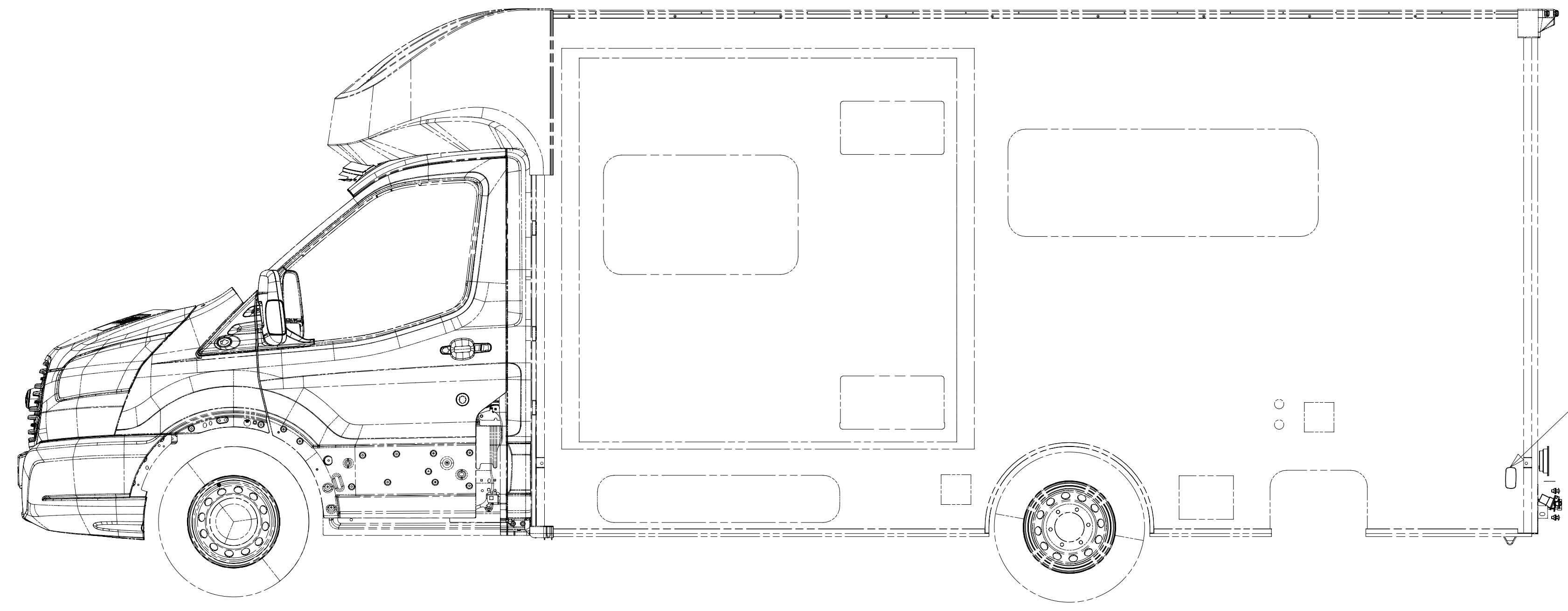

FOR ELECTRICAL  
TORQUE  
SPECIFICATIONS  
SEE DWG NO.  
128783-01-000

FOR  
ELECTRICAL  
CALLOUTS  
SEE DWG NO.  
121339-01-000



DSNR:		ALL DIMENSIONS ARE IN MILLIMETERS	
DFFR:		MATERIAL:	
UNSPECIFIED TOLERANCES:			
WHOLE DIM (X)	: 3		
ONE-PLACE (X.X)	: 1.5		
TWO-PLACE (X.XX)	: 0.50		
ANGLE	: 1°		
REFER TO ES0018 FOR FASTENER TIGHTENING GUIDELINES		WEIGHT: (LBS)	FIRST USED:
			16 423A

DESCRIPTION:  
**WIRING INSTL-EXTERIOR LAMPS**

SHEET:	ITEM/PART NO.:	REV
1 OF 2	000211438 / 30102001000	

REF: 1 05-Apr-2017

8 7 6 5 4 3 2 1

2 PIN HOUSING  
TO WIRE ASM-ROOF

WIRE ASM-CLEARANCE LAMP  
191816-01-000

LAMP ASM-CLEARANCE,FRONT  
170776-01-000 (5)

WIRE ASM-CLEARANCE LAMPS  
191817-01-000

LAMP ASM-CLEARANCE <sup>2</sup>

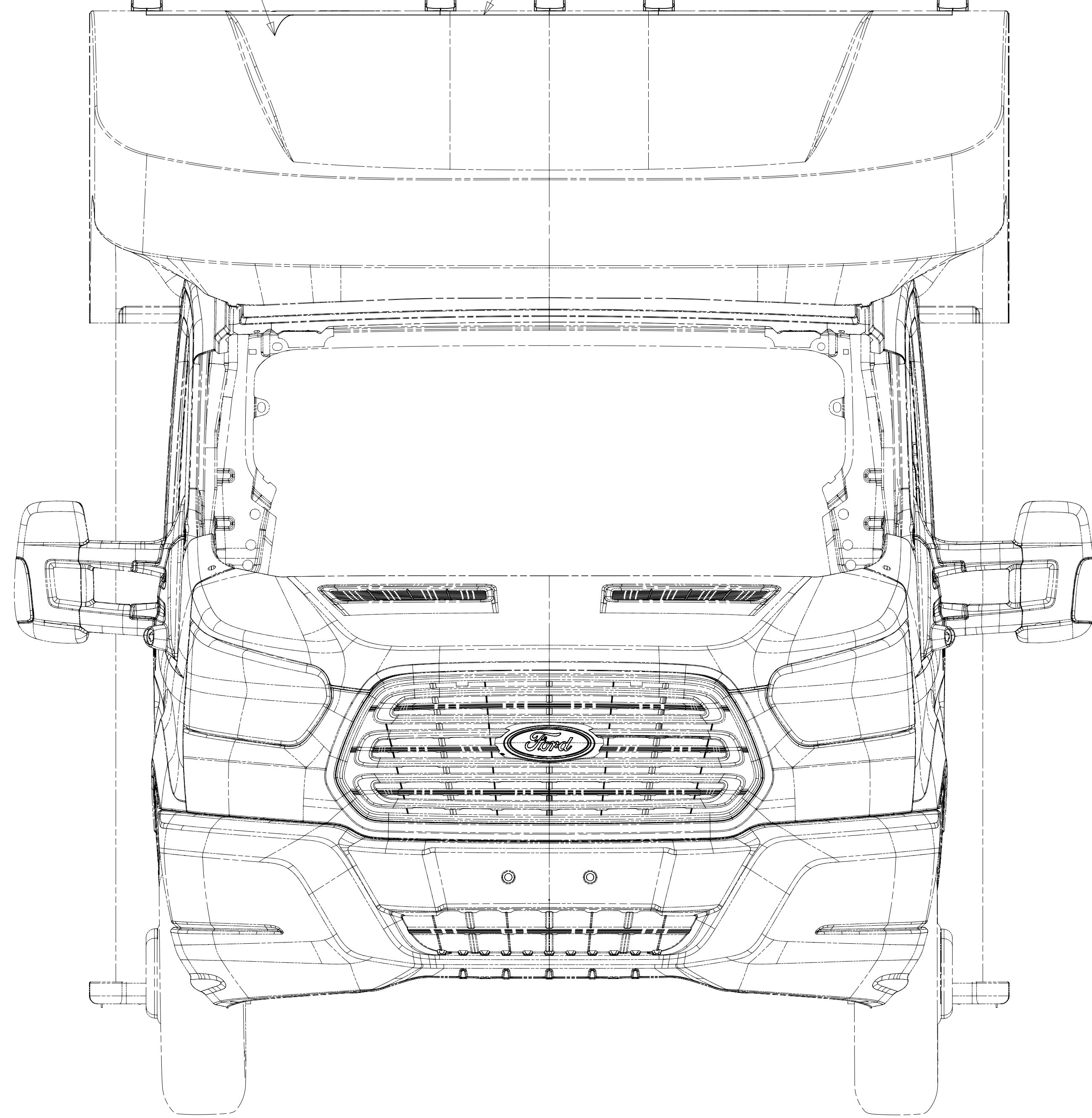

VIEW BA

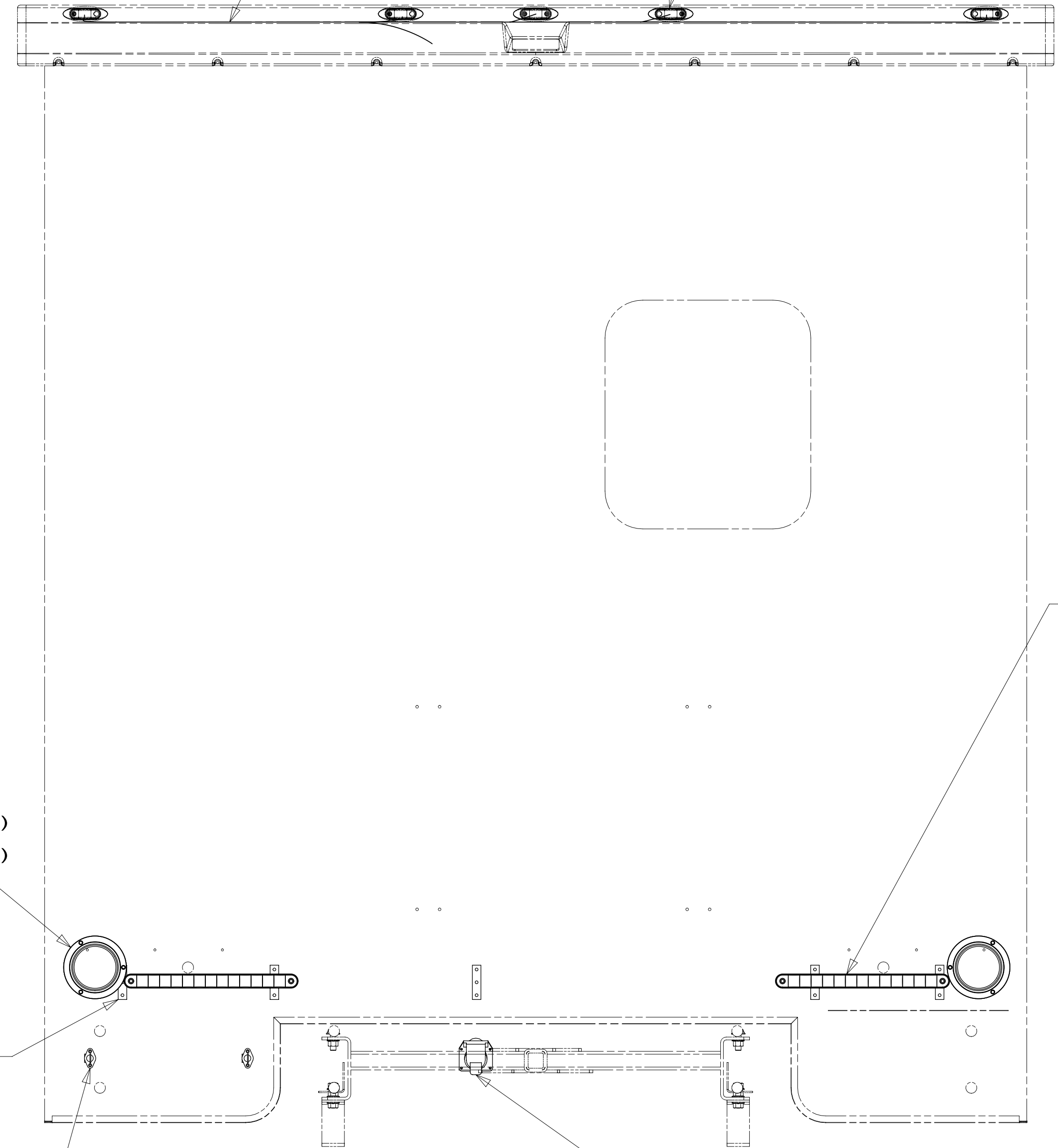

VIEW BB

<sup>3</sup> LAMP ASM-BACKUP  
184674-01-000 (2)  
BEZEL-LAMP  
184674-02-000 (2)  
SCREW  
G11-08-12U (6)

<sup>4</sup> STRAP-WHOLES  
(REF)  
WIRE TIE  
08343-02-000 (5)

LIGHT-LICENSE  
87201-01-000 (2)  
SCREW  
G11-06-12U (EXT)(4)

LAMP ASM-STOP/TURN/TAIL  
184653-01-000 (2)  
SCREW  
G11-08-12U (4) <sup>1</sup>

CONNECTOR-TRAILER  
157593-01-000  
SCREW  
101618-01-000 (4) <sup>240</sup>

- <sup>4</sup> CLAMP TRAILER HITCH AND EXTERIOR LAMP WIRE ALONG BOTTOM OF BACKWALL ASSEMBLY.
- <sup>3</sup> CUT CONNECTOR OFF OF LIGHT ASM. CONNECT CIRCUIT TR TO BLACK WIRE, CONNECT CIRCUIT MS TO WHITE WIRE.
- <sup>2</sup> SEE TRIM ASM-BACKWALL,UPPER FOR ADDITIONAL INFORMATION.
- <sup>1</sup> CONNECT CIRCUIT SC OR SD TO RED WIRE, CONNECT CIRCUIT MM TO BROWN WIRE, CONNECT CIRCUIT MS TO WHITE WIRE.

NOTES:

- <sup>240</sup> TRAILER HITCH
- <sup>265</sup> CODES/STANDARDS-CSA/CMVSS
- <sup>1B1</sup> CODES/STANDARDS USA

FOR ELECTRICAL  
TORQUE  
SPECIFICATIONS  
SEE DWG NO.  
128783-01-000

FOR  
ELECTRICAL  
CALLOUTS  
SEE DWG NO.  
121339-01-000

DESCRIPTION: <b>WIRING INSTL-EXTERIOR LAMPS</b>	
SHEET: 2 OF 2	ITEM/PART NO: 000211438 / 30102001000
REV 1 05-Apr-2017	