

8

7

6

5

4

3

2

1

REV	ZONE	REVISION RECORD	DATE	DFTR-ORIG
A	---	INITIAL RELEASE	11/04/15	3650
B	SHT3	ADDED VIEW FOR WATER FILTER	12/21/16	3650

D

D

C

C

B

B

A

A

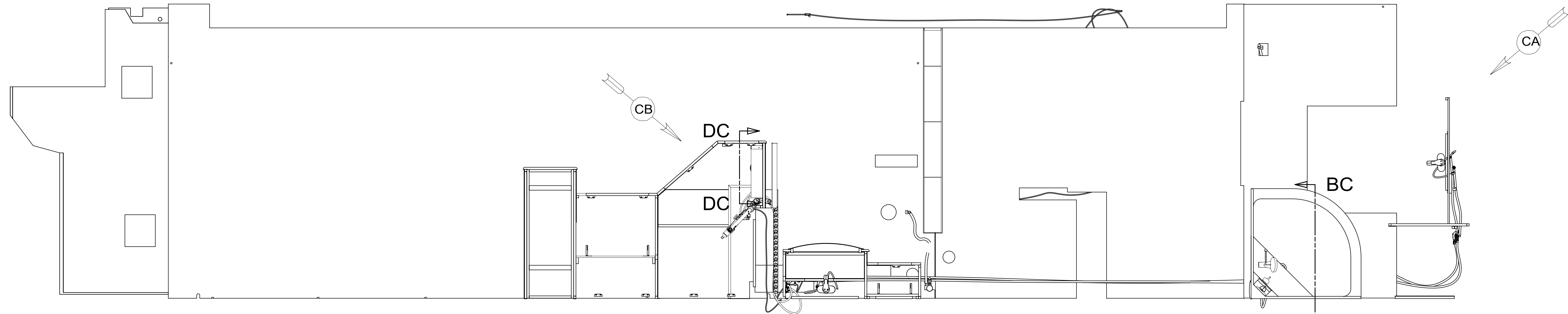

- 10. INSTALL FAUCET W/OUT BASEPLATE.
- 9. VALVE MUST REMAIN OPEN AFTER WATER TEST.
- 8. ALL CRIMP FITTINGS TO 1/2" PEX TUBING REQUIRE 1/2" CLAMP 140171-03-000.
- 7. ALL CRIMP FITTINGS TO 5/8" PEX TUBING REQUIRE 5/8" CLAMP 140171-04-000.
- 6. LABEL HOT AND COLD SUPPLY TUBES AND TAPE FITTING TO TUBE BEFORE CABINET SET TO PREVENT MOVEMENT.
- 5. ADD PIPE WRAP (LADDER SCRAP 110157-02-000) INSULATION.
- 4. ADD TEFLON TAPE 010405-02-000.
- 3. ALL TUBING TO BE SECURED AT 1200 INTERVALS MAXIMUM WITH CLAMP 010495-01-000 AND SCREW 000G67-10-12U OR EQUIVALENT.
- 2. TUBING TO BE INSTALLED WITH SUFFICIENT SLOPE TO PROVIDE DRAINAGE TO NEAREST VALVE.
- 1. PLASTIC FITTINGS TO BE SEALED WITH SEALANT 084456-01-000.

- 21S WASHER & DRYER-PAIR
- 21M WASHER/DRYER PREP

WINNEBAGO
COPYRIGHT 2016 WINNEBAGO INDUSTRIES, INC.

DSNR:	ALL DIMENSIONS ARE IN MILLIMETERS	
DFTR:	MATERIAL:	
UNSPECIFIED TOLERANCES:	WHOLE DIM (X) :	3
	ONE-PLACE (X.X) :	1.5
	TWO-PLACE (X.XX) :	0.50
	ANGLE :	1°
REFER TO ES0018 FOR FASTENER TIGHTENING GUIDELINES	WEIGHT: (LBS)	FIRST USED: (REF)
		17 P42E
DESCRIPTION: WATER SYSTEM INSTL		
SHEET: 1 OF 4	ITEM/PART NO: 000210439 / 30209001000	REV
	REF:	1 06-Jan-2017

X-X
FOR WATER CALLOUTS SEE DWG NO. 000209446 / 303369-01-000

NOTES:

8

7

6

5

4

3

2

1

06-Jan-2017

DROP ELL
135028-02-CHT
PLATE-COVER
189861-01-XXX
PLATE-COVER
143218-03-CHT

VACUUM BREAKER
176678-01-CHT

FAUCET-VALVE, SHOWER
180180-01-CHT
FAUCET-TRIM KIT
180180-02-CHT

SHOWER-HAND
187372-01-CHT

CLAMP-CLOSED
010497-10-000(2)

CLAMP-CLOSED
010495-01-000

BRACKET
131550-03-CHT

BREAKER-VACUUM
125697-04-000
CHECK VALVE
125697-03-000

FAUCET
178237-01-CHT

SECTION BC-BC
(SHOWN W/OUT CABINETS)

DETAIL BB
(SHOWN W/OUT CABINETS)

VIEW BA

DETAIL BB

DESCRIPTION:		
WATER SYSTEM INSTL		
SHEET:	ITEM/PART NO.:	REV
2 OF 4	000210439 / 30209001000	

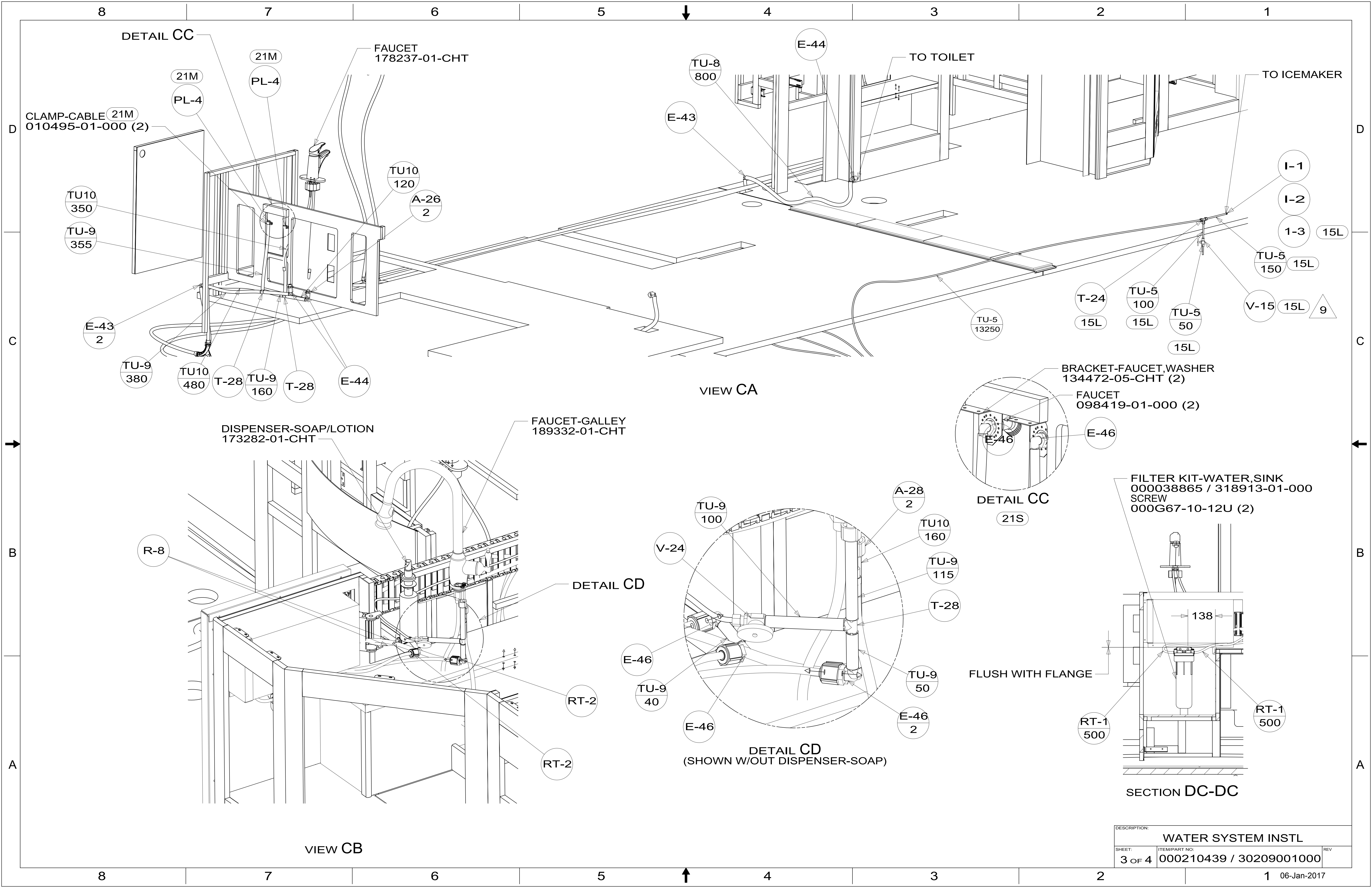

DESCRIPTION:		
WATER SYSTEM INSTL		
SHEET:	ITEM/PART NO.:	REV:
3 OF 4	000210439 / 30209001000	

