

REV	ZONE	REVISION RECORD	DATE	DFTR-ORIG
A	---	INITIAL RELEASE	11/04/15	3650
B	SHT2 SHT3	RE-ROUTE LINES FOR WINTERIZATION VALVE	11/09/15	6437
C	S2BD	DIMS 550 WAS 571, 250 WAS 206	11/18/15	3650-6437
D	SHT3	F-4 WAS 137169-01-CHT	12/22/15	3650-3508
E	SHT3	F-10 WAS F-4	01/07/16	3650-5643
F	S2B8	CHG TU-9/1420 TO TU-9/1360 & TU10/1555 TO TU10/1420	01/13/16	7786-3508
G	S2C6	ADD MISSING CALLOUT TU10/810	01/25/16	7786-3508
H	S3D1	REMOVE 1 OF THE PLATE-ALUM	06/10/16	7786-5472
J	S3D7	CHG LENGTH OF TU-4	08/18/16	7786-5472
K	---	CHG FITINGS ALL SHTS	9-27-16	1600-1600
L	SHT2	LENGTH CHANGES	11/28/16	3650-4373
M	SHT3	REPLACED FILTER	12-22-16	0626-1600

- 9. ALL CRIMP FITTINGS TO 3/4" PEX TUBING REQUIRE 3/4" CLAMP 140171-05-000.
- 8. ALL CRIMP FITTINGS TO 1/2" PEX TUBING REQUIRE 1/2" CLAMP 140171-03-000.
- 7. ALL CRIMP FITTINGS TO 5/8" FLEX TUBING REQUIRE 5/8" CLAMP 140171-04-000.
- 6 LABEL HOT AND COLD SUPPLY TUBES AND TAPE FITTING TO TUBE BEFORE CABINET SET TO PREVENT MOVEMENT.
- 5 ADD PIPE WRAP (LADDER SCRAP 110157-02-000) INSULATION.
- 4 ADD TEFLON TAPE 010405-02-000.
- 3. ALL TUBING TO BE SECURED AT 1200 INTERVALS MAXIMUM WITH CLAMP 010495-01-000 AND SCREW 000G67-10-12U OR EQUIVALENT.
- 2. TUBING TO BE INSTALLED WITH SUFFICIENT SLOPE TO PROVIDE DRAINAGE TO NEAREST VALVE.
- 1. PLASTIC FITTINGS TO BE SEALED WITH SEALANT 084456-01-000.

- 29B WATER PURIFIER
- 53E WATER SYS WINTERIZATION PKG
- 64R EXTERIOR WASH STATION

WINNEBAGO
COPYRIGHT 2017 WINNEBAGO INDUSTRIES, INC.

DSNR:	ALL DIMENSIONS ARE IN MILLIMETERS	
DFTR:		
UNSPECIFIED TOLERANCES:		MATERIAL:
WHOLE DIM (X) :	3	
ONE-PLACE (X.X) :	1.5	
TWO-PLACE (X.XX) :	0.50	
ANGLE :	1°	
REFER TO ES0018 FOR FASTENER TIGHTENING GUIDELINES	WEIGHT: (LBS)	FIRST USED: (REF)
		16 623D
DESCRIPTION: WATER SYSTEM INSTL		
SHEET: 1 OF 3	ITEM/PART NO: 000208911 / 30092601000	REV:

X-X
FOR WATER CALLOUTS SEE DWG NO. 000209446 / 303369-01-000

300926

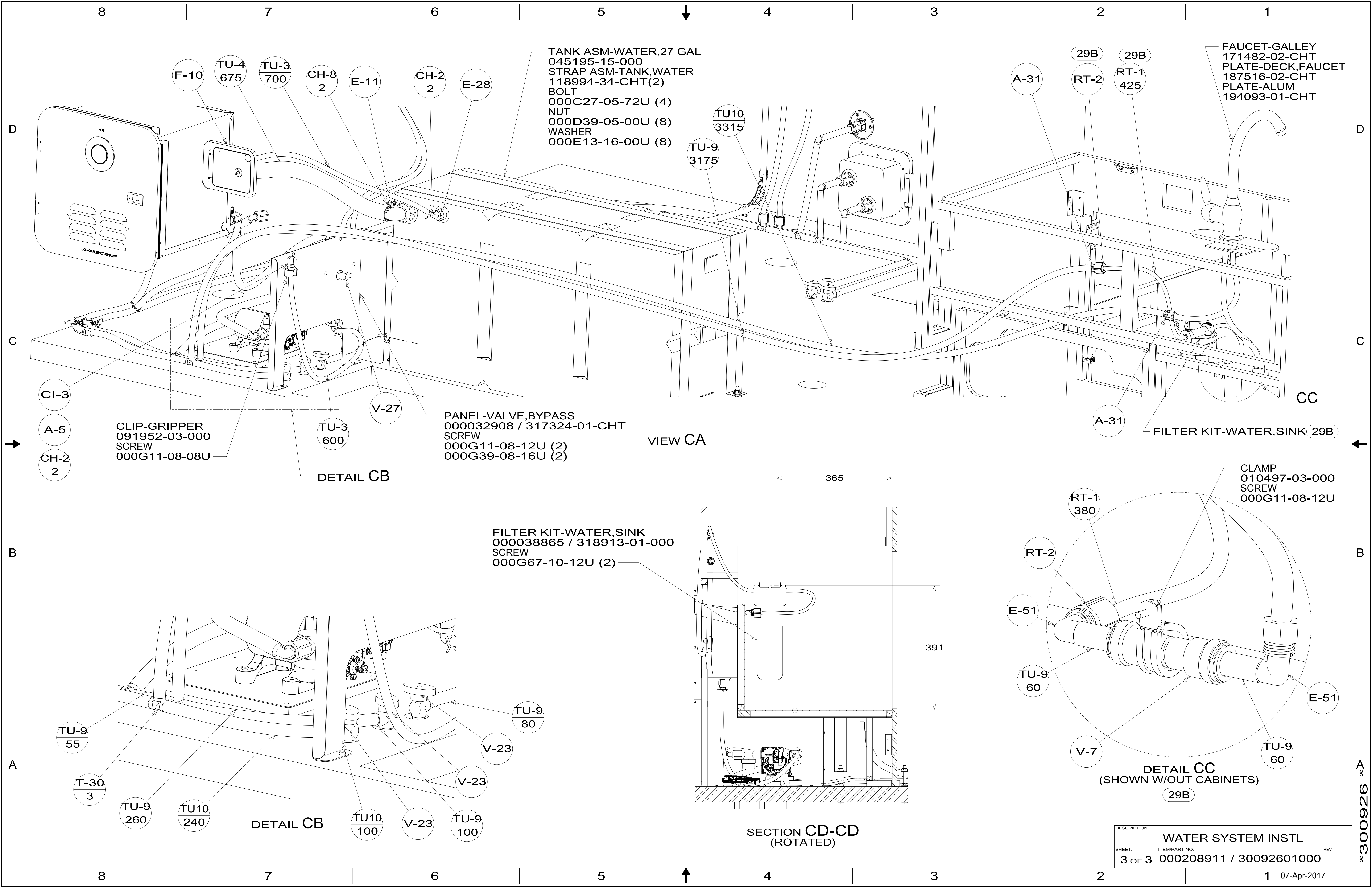

TANK ASM-WATER,27 GAL
 045195-15-000
 STRAP ASM-TANK,WATER
 118994-34-CHT(2)
 BOLT
 000C27-05-72U (4)
 NUT
 000D39-05-00U (8)
 WASHER
 000E13-16-00U (8)

FAUCET-GALLEY
 171482-02-CHT
 PLATE-DECK,FAUCET
 187516-02-CHT
 PLATE-ALUM
 194093-01-CHT

VIEW CA

FILTER KIT-WATER,SINK (29B)

DETAIL CB

FILTER KIT-WATER,SINK
 000038865 / 318913-01-000
 SCREW
 000G67-10-12U (2)

SECTION CD-CD
 (ROTATED)

DETAIL CC
 (SHOWN W/OUT CABINETS)
 (29B)

DESCRIPTION:		
WATER SYSTEM INSTL		
SHEET:	ITEM/PART NO:	REV
3 OF 3	000208911 / 30092601000	

*300926