

8 7 6 5 4 3 2 1

BB

LAMP-MARKER,
W RED LENS,BLK
193802-04-000
SCREW
G11-08-12U (EXT)(2)

LAMP ASM-PORCH
184120-01-CHT
SCREW
G68-06-10U (2)
CONNECTOR
58028-01-000 (2)

BA

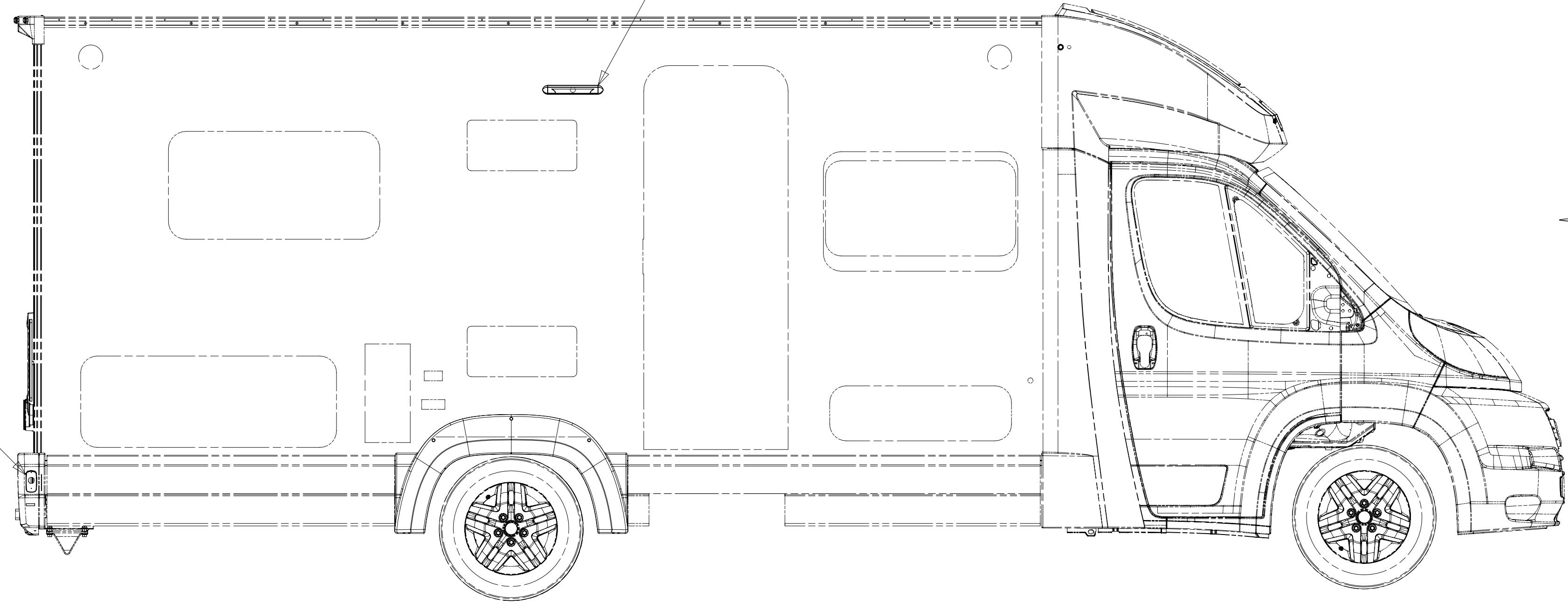

CA

LAMP-MARKER,
W RED LENS,BLK
193802-04-000
SCREW
G11-08-12U (EXT)(2)

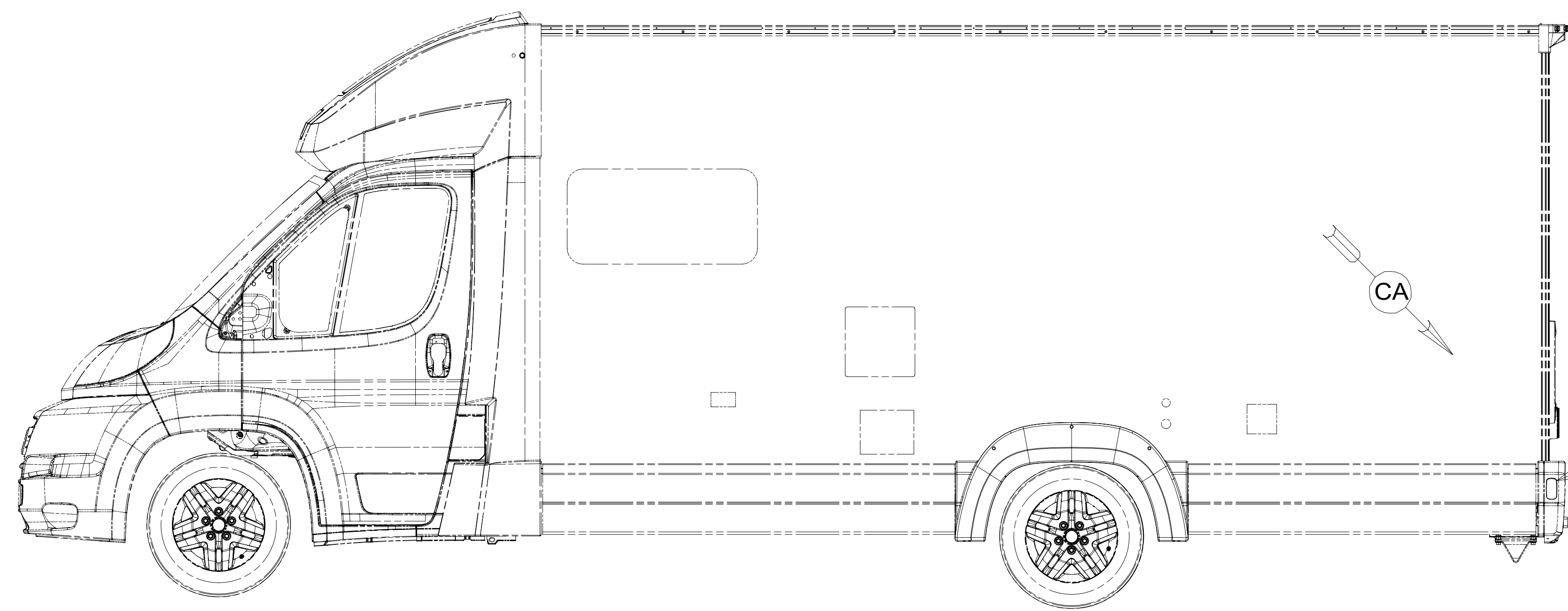

265 CODES/STANDARDS-CSA/CMVSS

1B1 CODES/STANDARDS USA

1B1 265

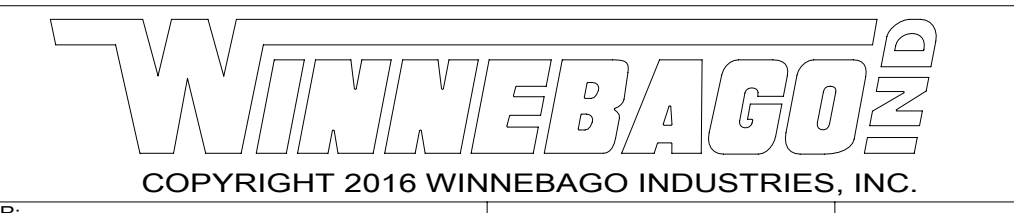

DSNR:		ALL DIMENSIONS ARE IN MILLIMETERS	
DFFR:		MATERIAL:	
UNSPECIFIED TOLERANCES:			
WHOLE DIM (X)	: 3		
ONE-PLACE (X.X)	: 1.5		
TWO-PLACE (X.XX)	: 0.50		
ANGLE	: 1°		
REFER TO ES0018 FOR FASTENER TIGHTENING GUIDELINES		WEIGHT: (LBS)	FIRST USED:
			16 600-SE

FOR ELECTRICAL TORQUE SPECIFICATIONS SEE DWG NO. 128783-01-000

FOR ELECTRICAL CALLOUTS SEE DWG NO. 121339-01-000

DESCRIPTION: WIRING INSTL-EXTERIOR LAMPS

SHEET: 1 OF 3 ITEM/PART NO: 000180929 / 30093101000 REV

REF: 1 08-Jun-2017

8 7 6 5 4 3 2 1

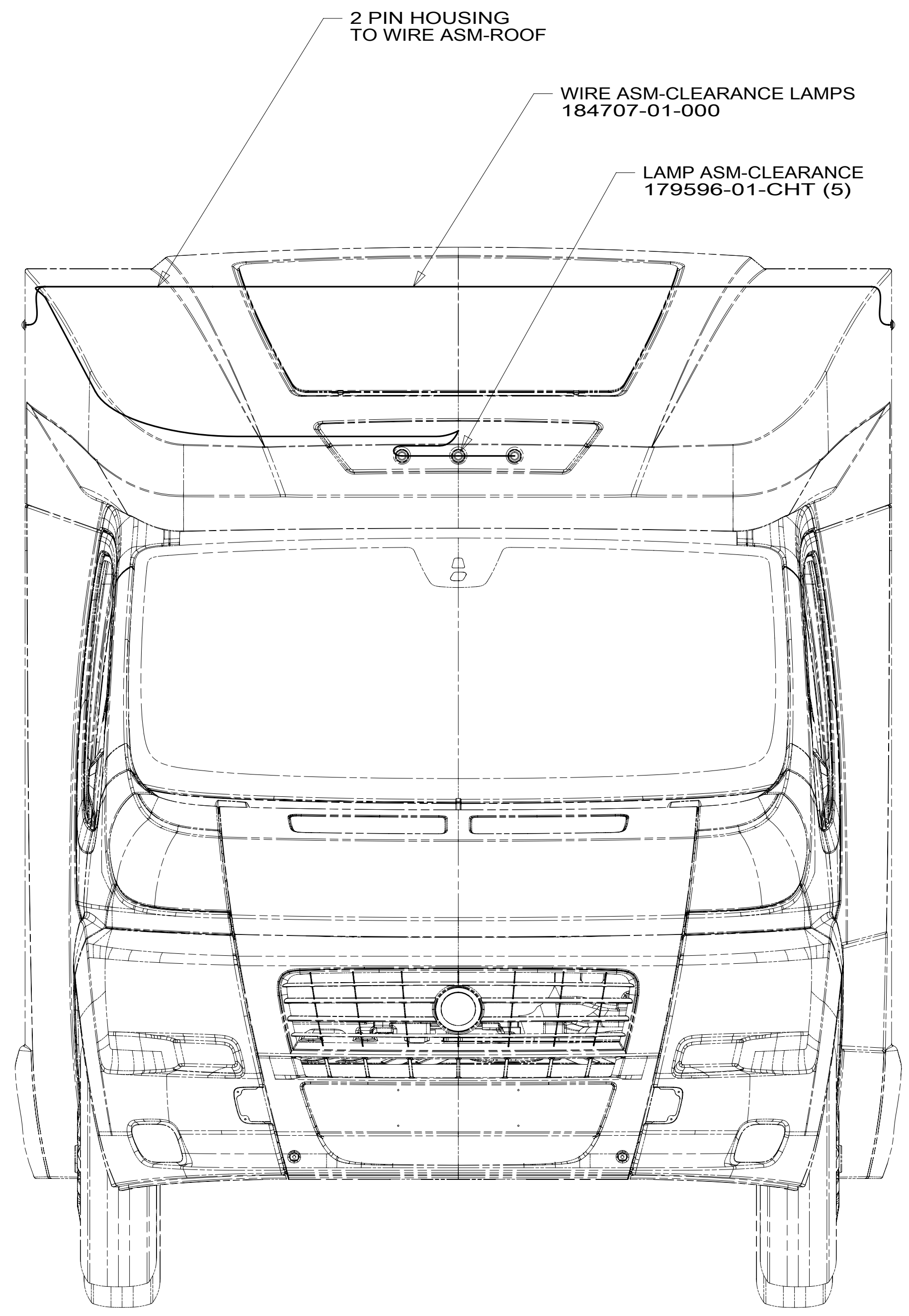

VIEW BA

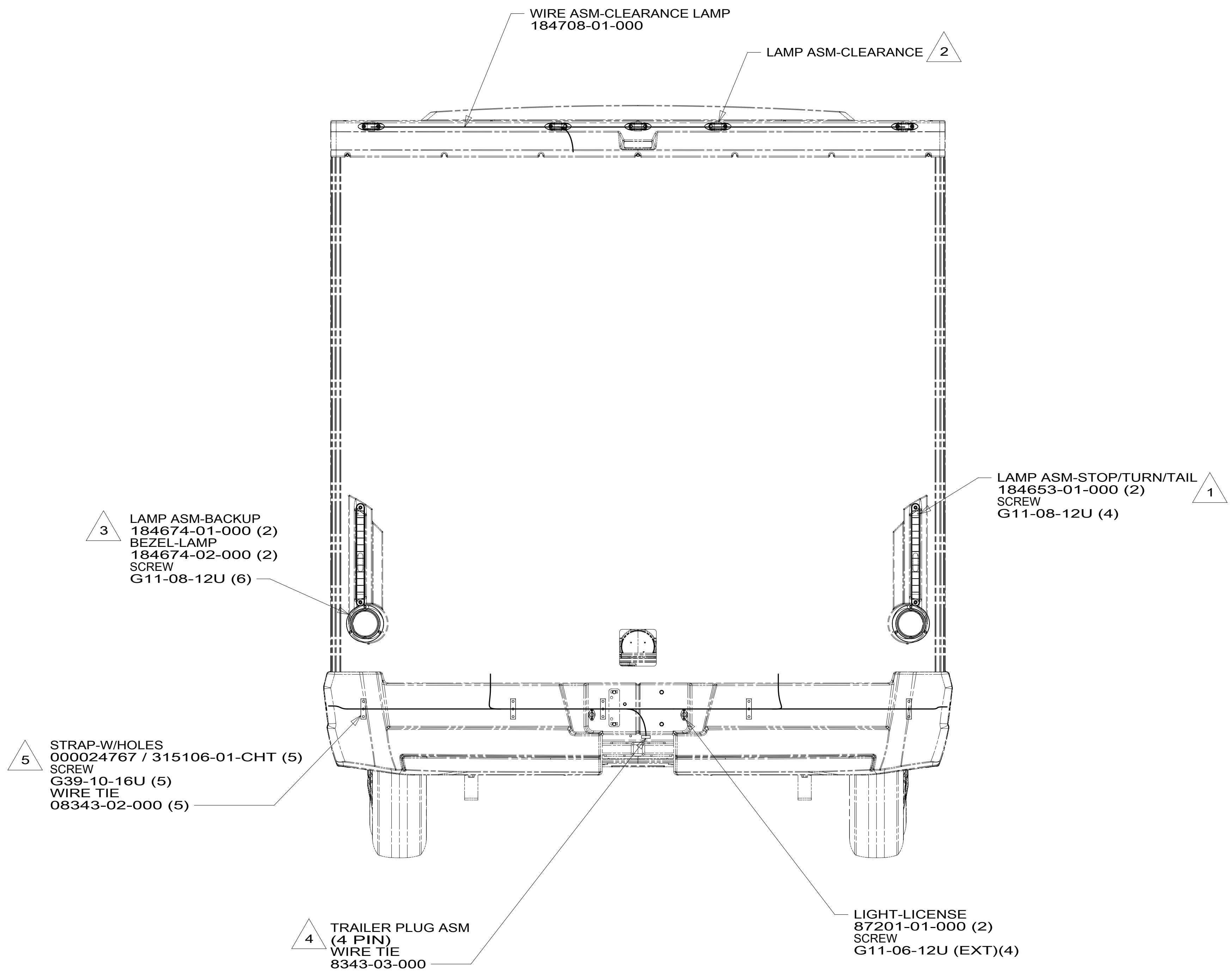

VIEW BB

- NOTES:
- 5 CLAMP TRAILER HITCH AND EXTERIOR LAMP WIRE ALONG BOTTOM OF BACKWALL ASSEMBLY.
 - 4 WIRE TIE 4-PIN TRAILER PLUG TO HITCH ASSEMBLY NEAR RECEIVER.
 - 3 CUT CONNECTOR OFF OF LIGHT ASM. CONNECT CIRCUIT TR TO BLACK WIRE, CONNECT CIRCUIT MS TO WHITE WIRE.
 - 2 SEE TRIM ASM-BACKWALL, UPPER FOR ADDITIONAL INFORMATION.
 - 1 CONNECT CIRCUIT SC OR SD TO RED WIRE, CONNECT CIRCUIT MM TO BROWN WIRE, CONNECT CIRCUIT MS TO WHITE WIRE.

265 CODES/STANDARDS-CSA/CMVSS
 1B1 CODES/STANDARDS USA

FOR ELECTRICAL TORQUE SPECIFICATIONS SEE DWG NO. 128783-01-000

FOR ELECTRICAL CALLOUTS SEE DWG NO. 121339-01-000

DESCRIPTION:	
WIRING INSTL-EXTERIOR LAMPS	
SHEET: 2 OF 3	ITEM/PART NO.: 000180929 / 30093101000
REV	

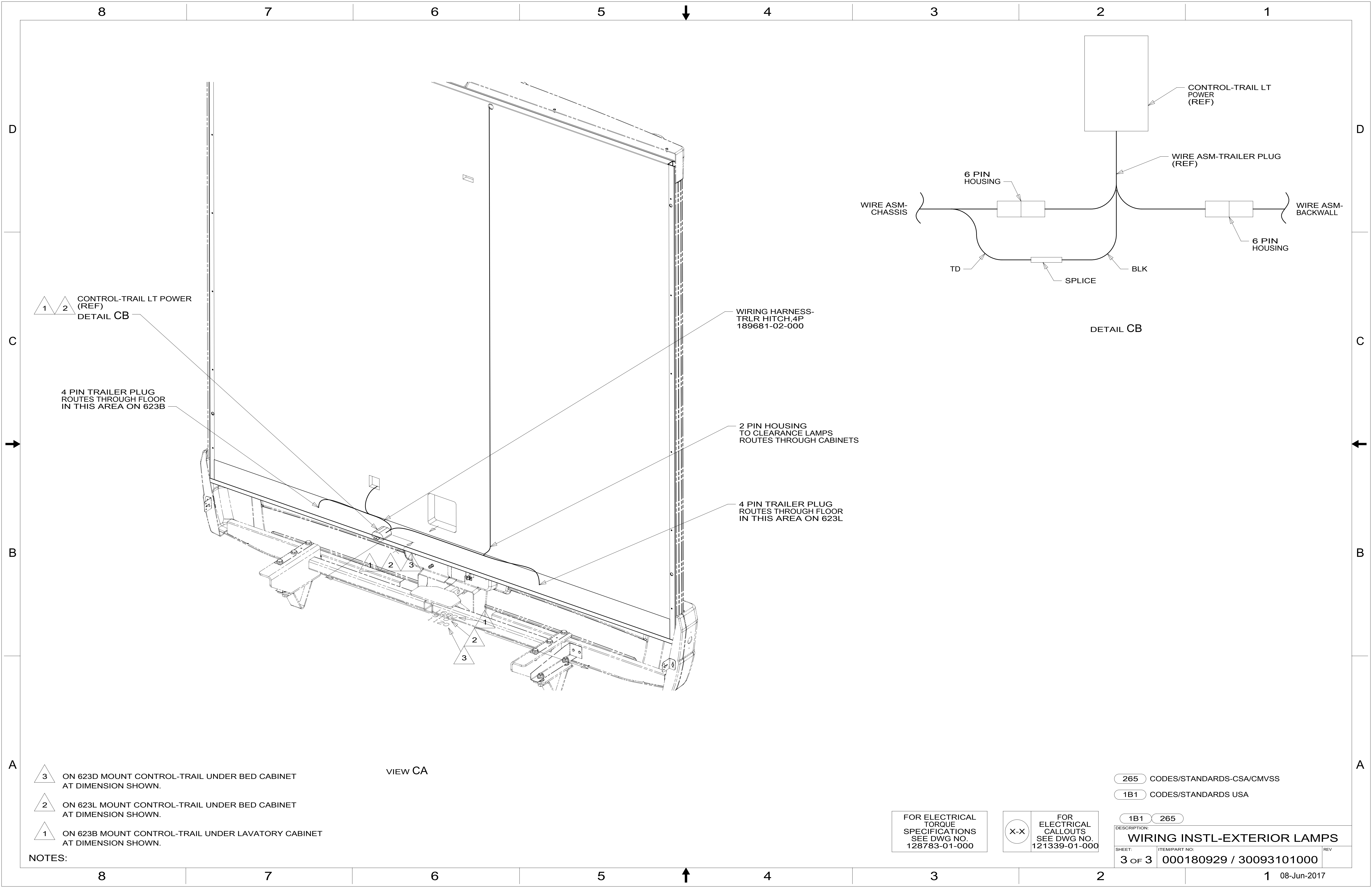

1 2 CONTROL-TRAIL LT POWER (REF) DETAIL CB

4 PIN TRAILER PLUG ROUTES THROUGH FLOOR IN THIS AREA ON 623B

WIRING HARNESS-TRLR HITCH,4P 189681-02-000

2 PIN HOUSING TO CLEARANCE LAMPS ROUTES THROUGH CABINETS

4 PIN TRAILER PLUG ROUTES THROUGH FLOOR IN THIS AREA ON 623L

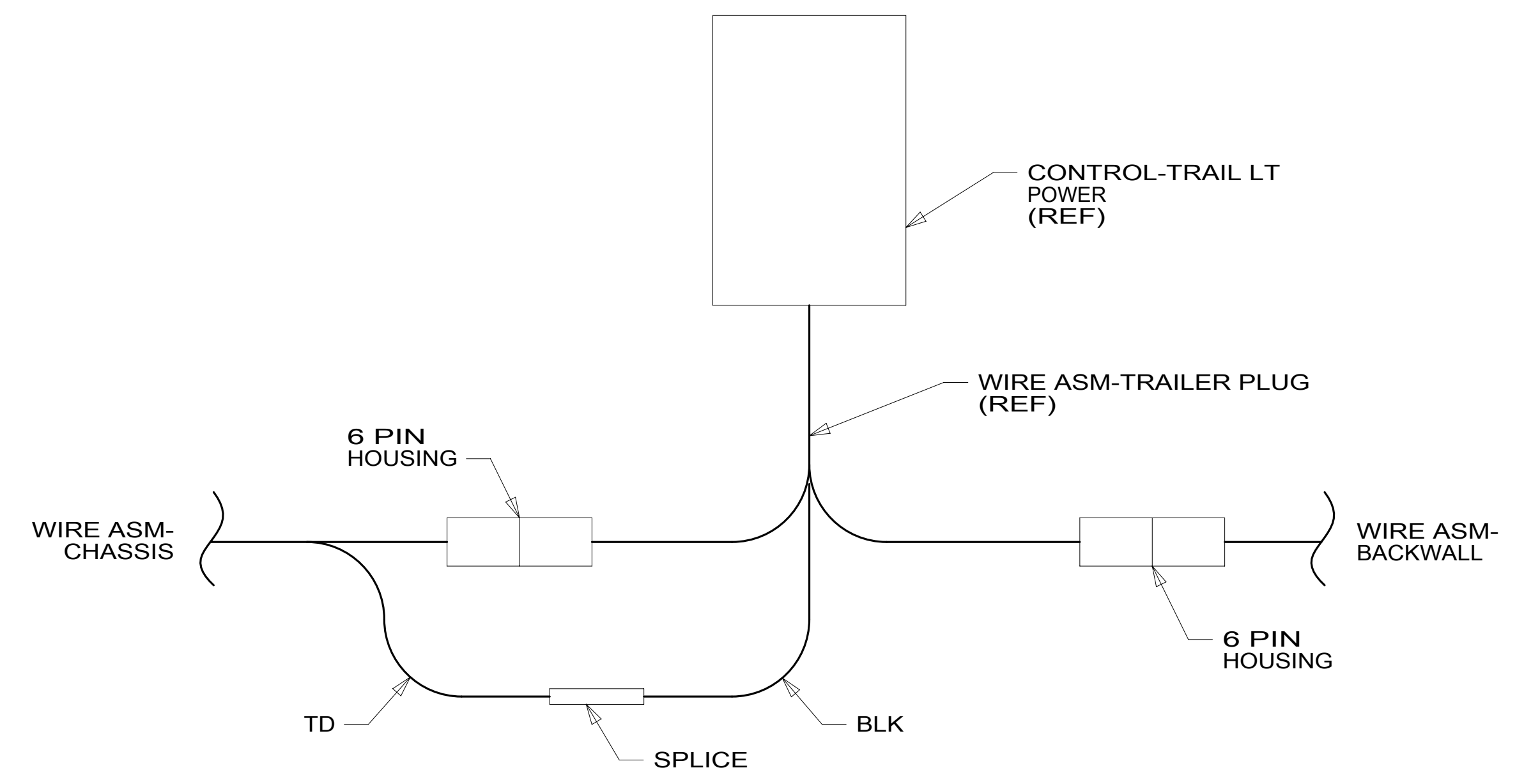

DETAIL CB

- NOTES:
- 3 ON 623D MOUNT CONTROL-TRAIL UNDER BED CABINET AT DIMENSION SHOWN.
 - 2 ON 623L MOUNT CONTROL-TRAIL UNDER BED CABINET AT DIMENSION SHOWN.
 - 1 ON 623B MOUNT CONTROL-TRAIL UNDER LAVATORY CABINET AT DIMENSION SHOWN.

VIEW CA

FOR ELECTRICAL TORQUE SPECIFICATIONS SEE DWG NO. 128783-01-000

FOR ELECTRICAL CALLOUTS SEE DWG NO. 121339-01-000

- 265 CODES/STANDARDS-CSA/CMVSS
- 1B1 CODES/STANDARDS USA

DESCRIPTION:	
WIRING INSTL-EXTERIOR LAMPS	
SHEET:	ITEM/PART NO.:
3 OF 3	000180929 / 30093101000
REV	