

8 7 6 5 4 3 2 1

D
C
B
A

D
C
B
A

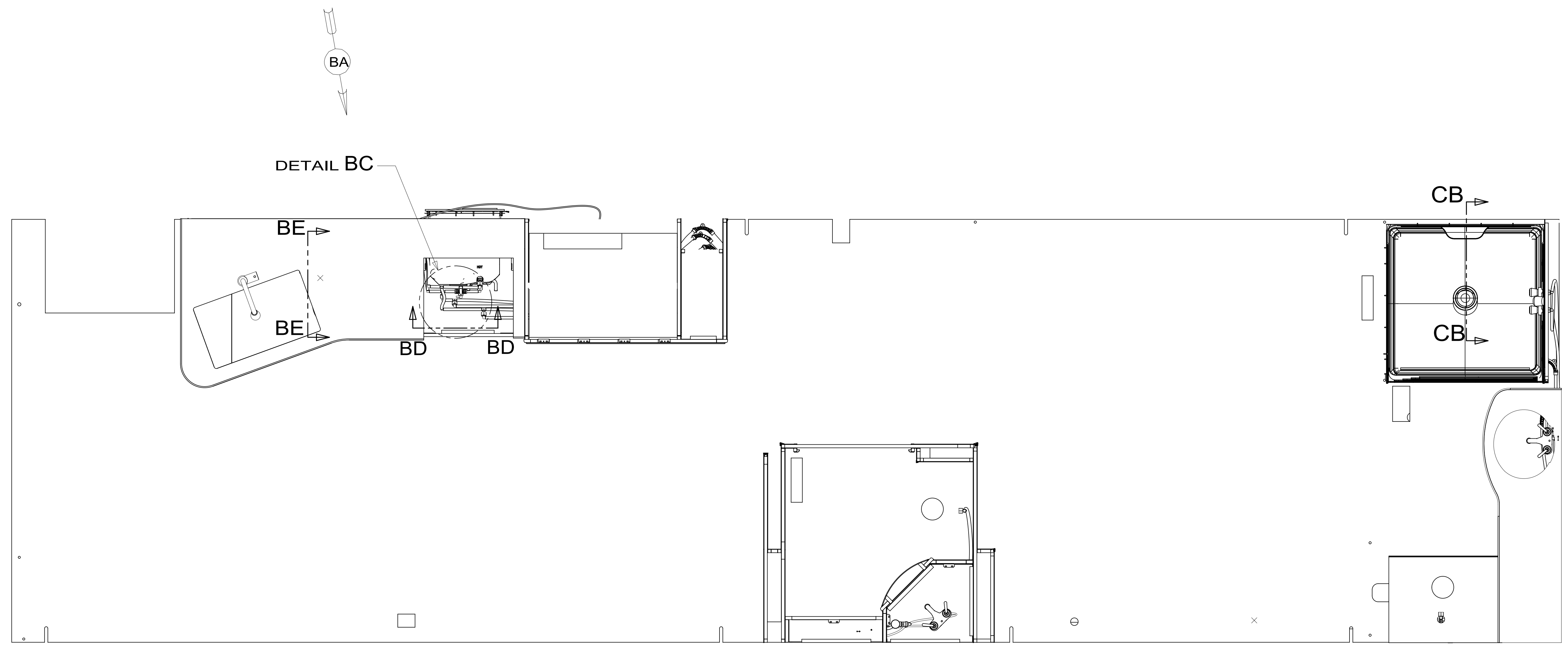

9. FLUSHING SYSTEM REQUIRES 125697-06-000 INSTRUCTION SHEET.
8. ALL CRIMP FITTINGS TO PEX TUBING REQUIRE 1/2" CLAMP 140171-03-000.
7. ALL CRIMP FITTINGS TO PEX TUBING REQUIRE 5/8" CLAMP 140171-04-000.
- 6 LABEL HOT AND COLD SUPPLY TUBES AND TAPE FITTING TO TUBE BEFORE CABINET SET TO PREVENT MOVEMENT.
- 5 ADD PIPE WRAP (LADDER SCRAP 110157-02-000) INSULATION.
- 4 ADD TEFLON TAPE 010405-02-000.
3. ALL TUBING TO BE SECURED AT 1200 INTERVALS MAXIMUM WITH CLAMP 010495-01-000 AND SCREW 000G67-10-12U OR EQUIVALENT.
2. TUBING TO BE INSTALLED WITH SUFFICIENT SLOPE TO PROVIDE DRAINAGE TO NEAREST VALVE.
1. PLASTIC FITTINGS TO BE SEALED WITH SEALANT 084456-01-000.

NOTES:

- 79W REFRIGERATOR-4 DOOR
- 144 REFRIGERATOR-DOUBLE DOOR

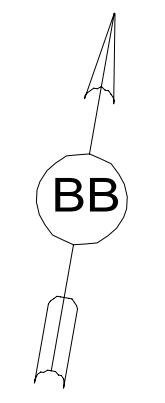

X-X

FOR WATER CALLOUTS SEE DWG NO. 116230-01-000



DSNR:		ALL DIMENSIONS ARE IN MILLIMETERS	
DIFFR:		MATERIAL:	
UNSPECIFIED TOLERANCES:			
WHOLE DIM (X)	3		
ONE-PLACE (X.X)	1.5		
TWO-PLACE (X.XX)	0.50		
ANGLE	1°		
REFER TO ES0018 FOR FASTENER TIGHTENING GUIDELINES		WEIGHT: (LBS)	FIRST USED: (REF)
			16 E35B
DESCRIPTION: WATER SYSTEM INSTL			
SHEET: 1 OF 5	ITEM/PART NO: 000180200 / 30053301000	REV	

8 7 6 5 4 3 2 1

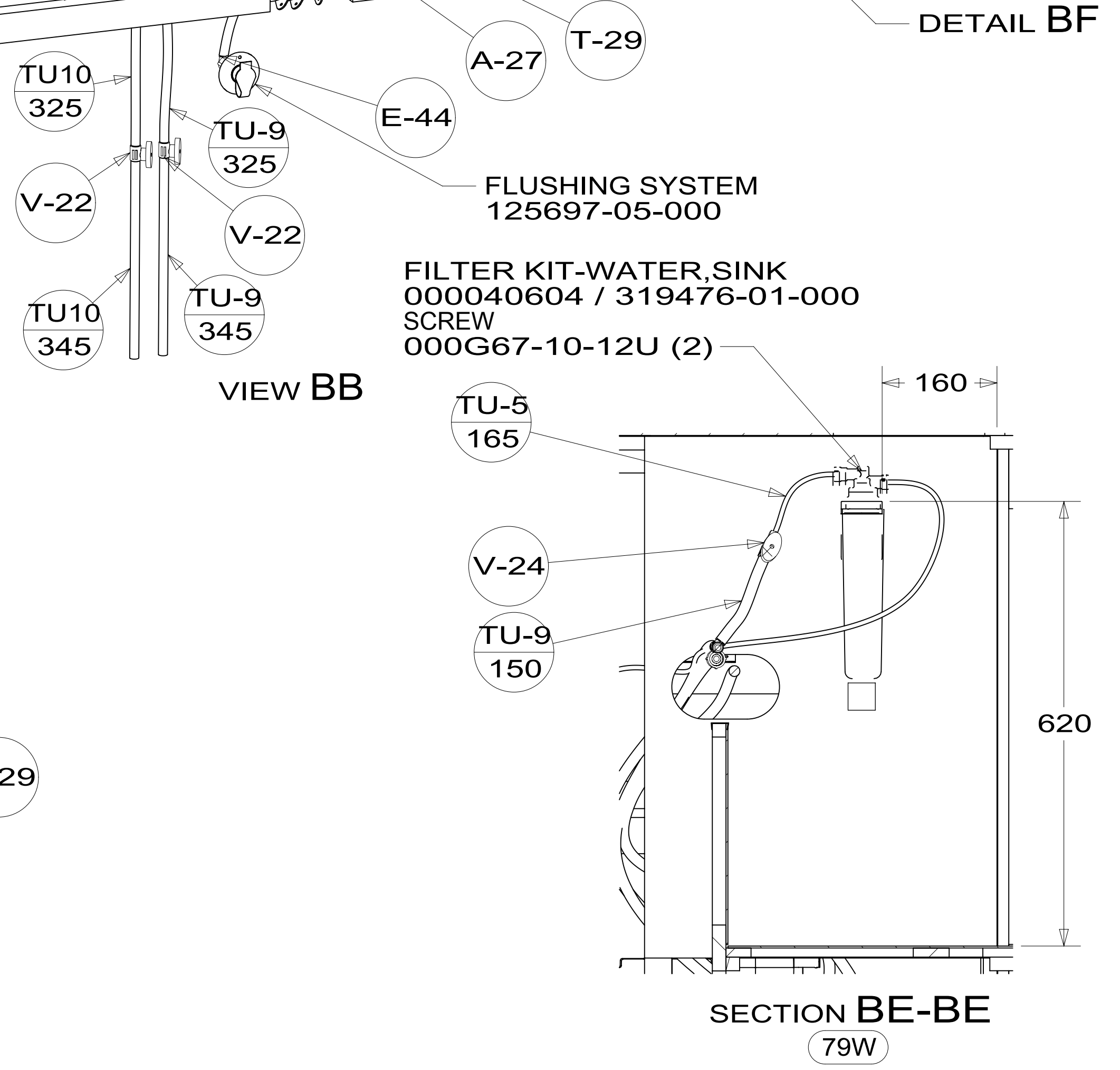
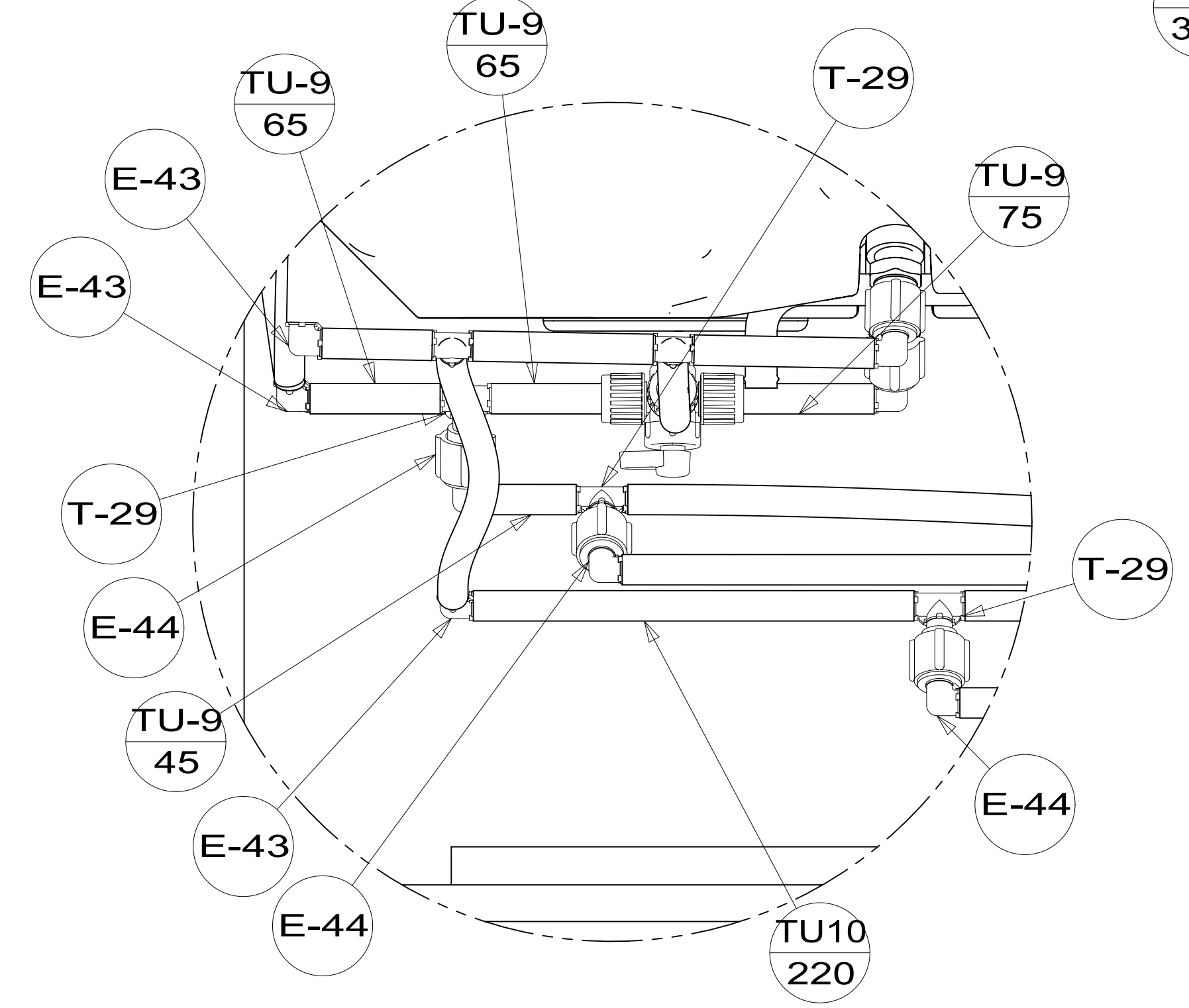
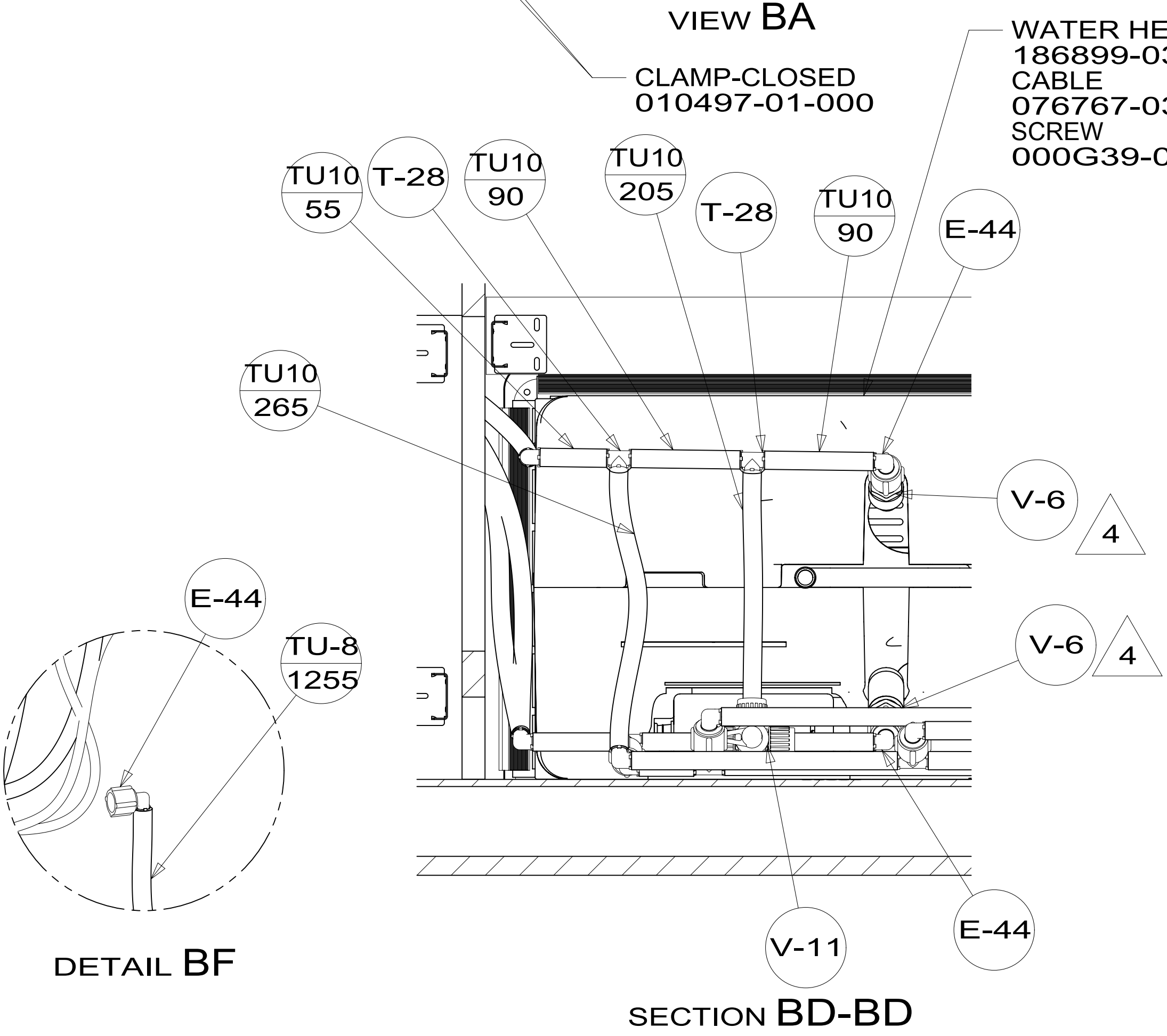
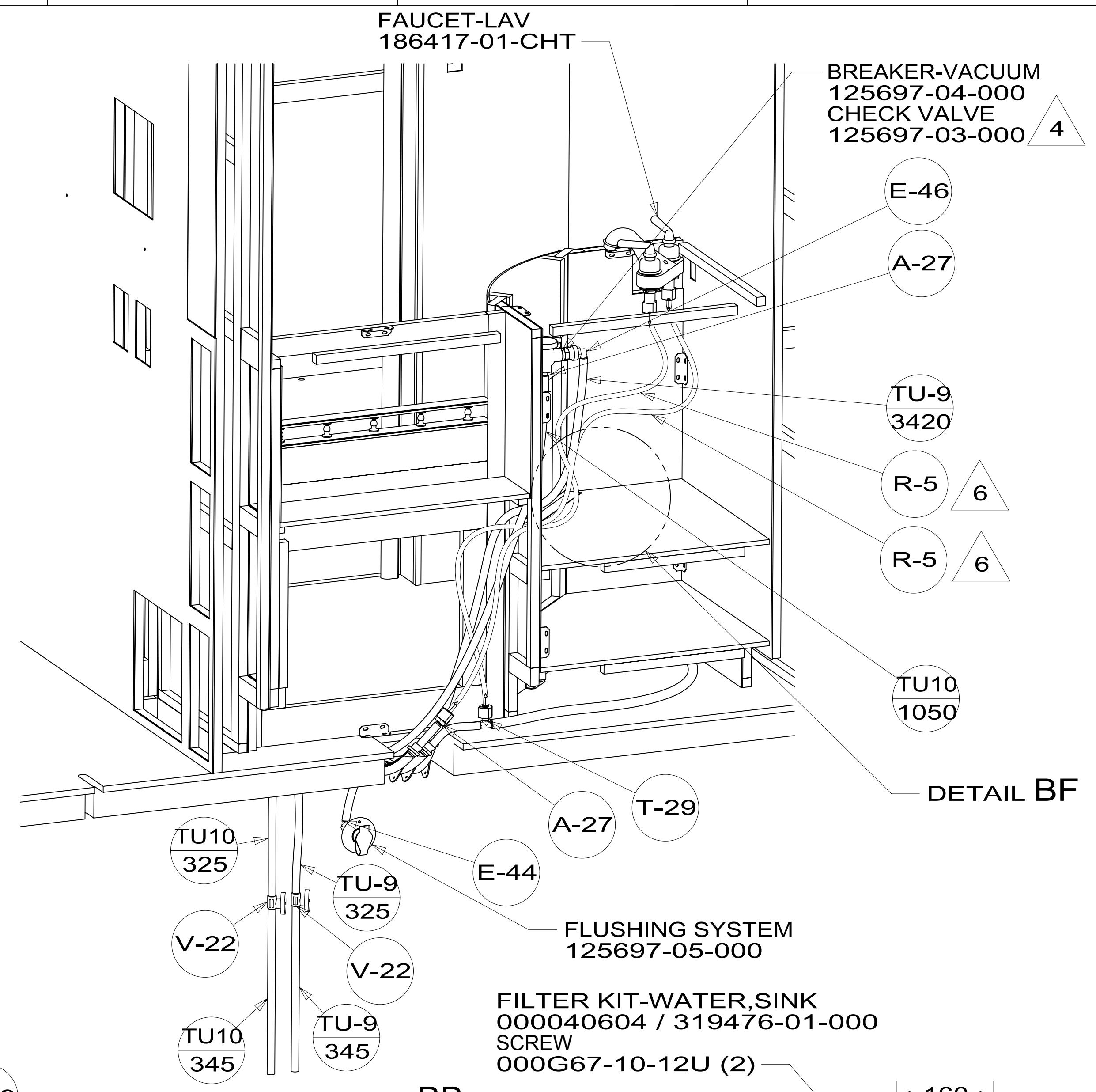
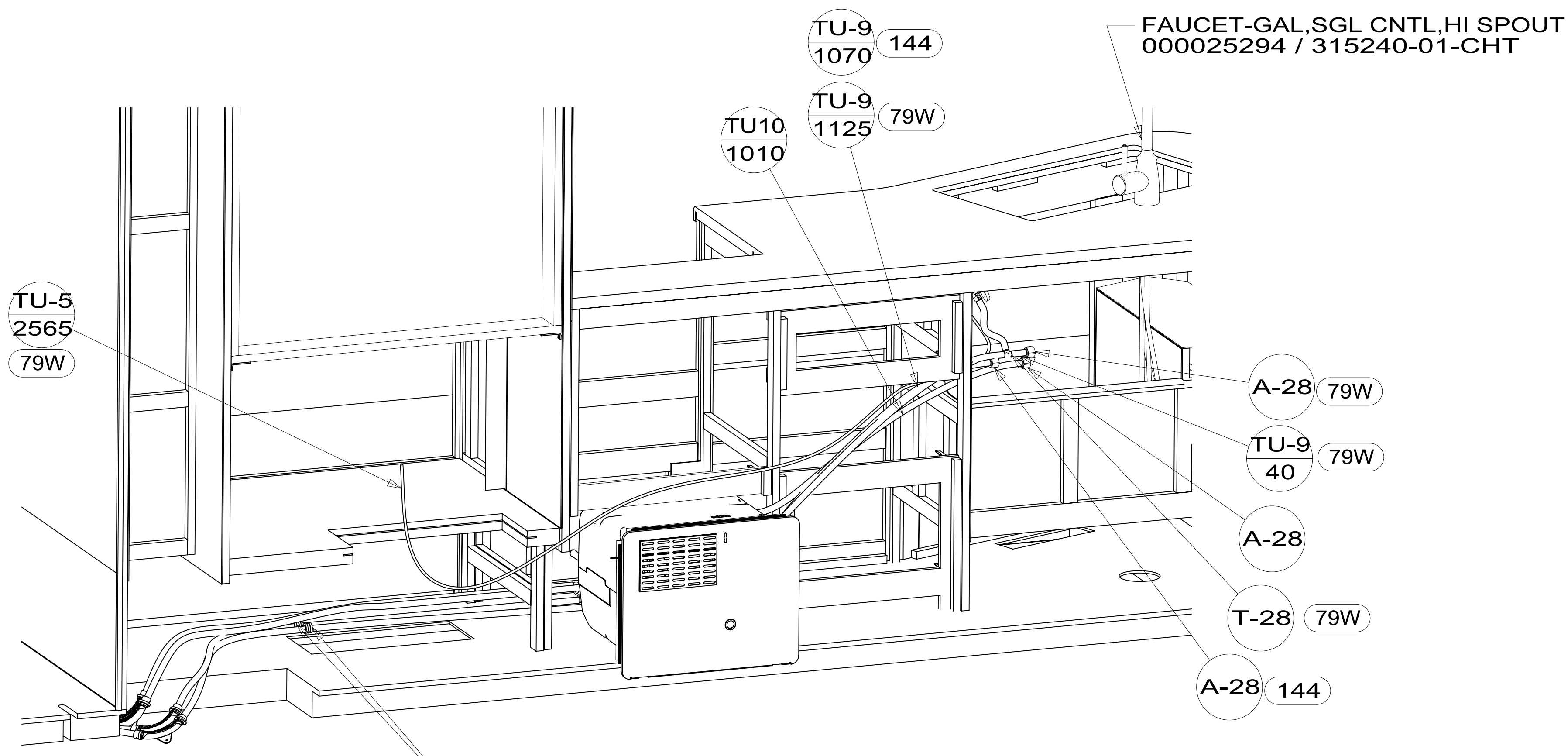

DESCRIPTION:		
WATER SYSTEM INSTL		
SHEET:	ITEM/PART NO:	REV
2 OF 5	000180200 / 30053301000	

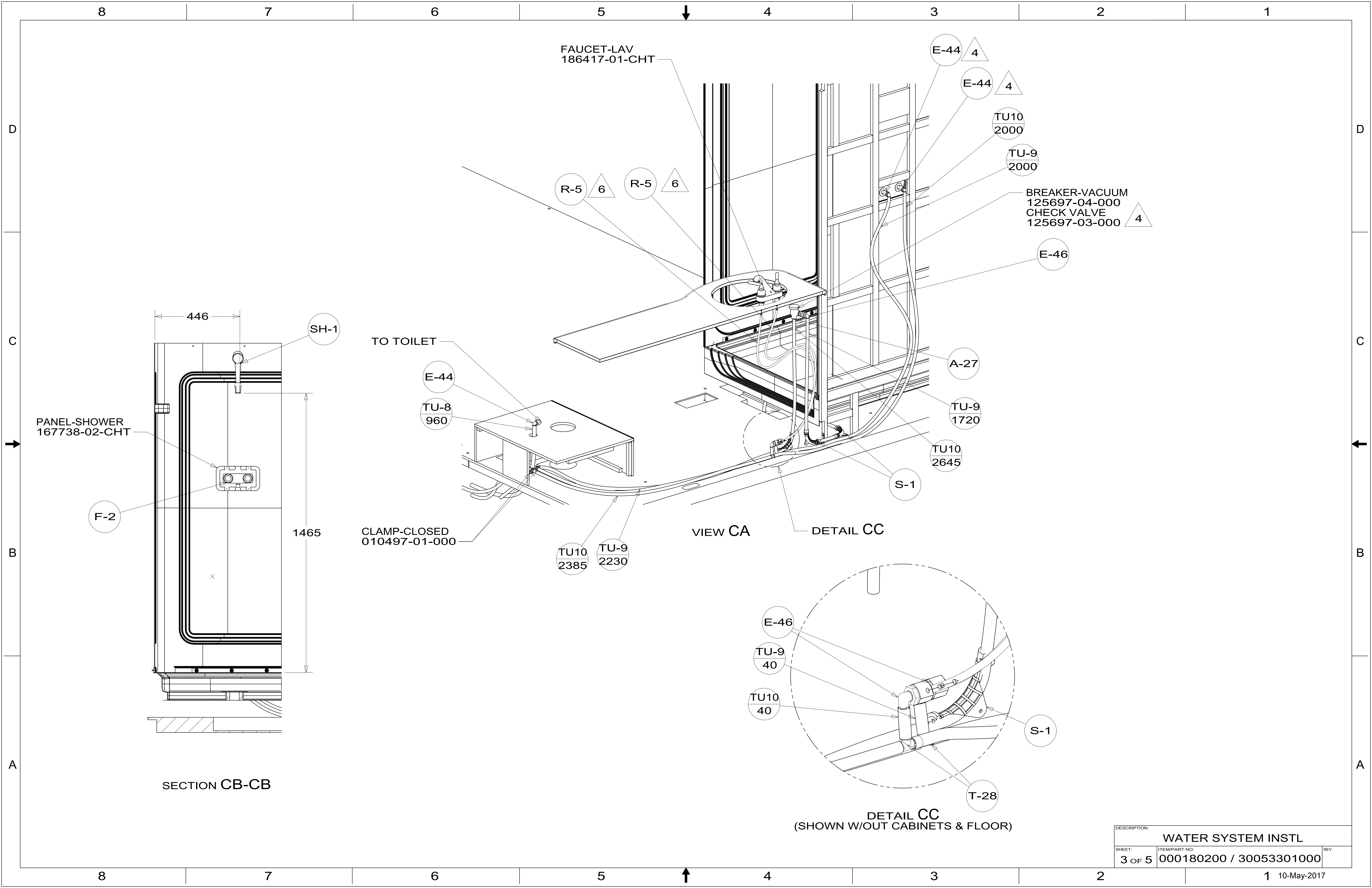

DESCRIPTION:		
WATER SYSTEM INSTL		
SHEET:	ITEM/PART NO:	REV
3 OF 5	000180200 / 30053301000	

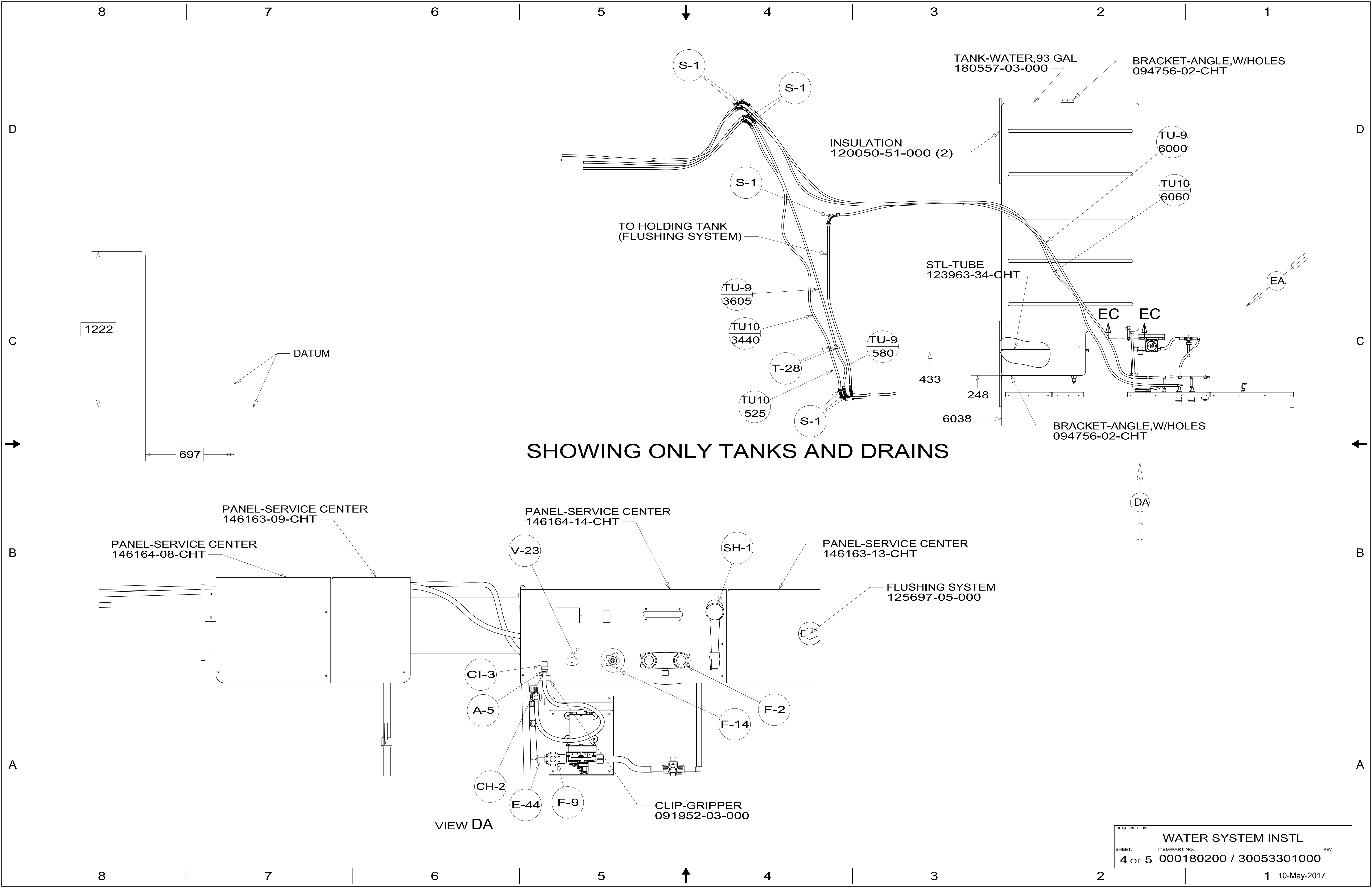

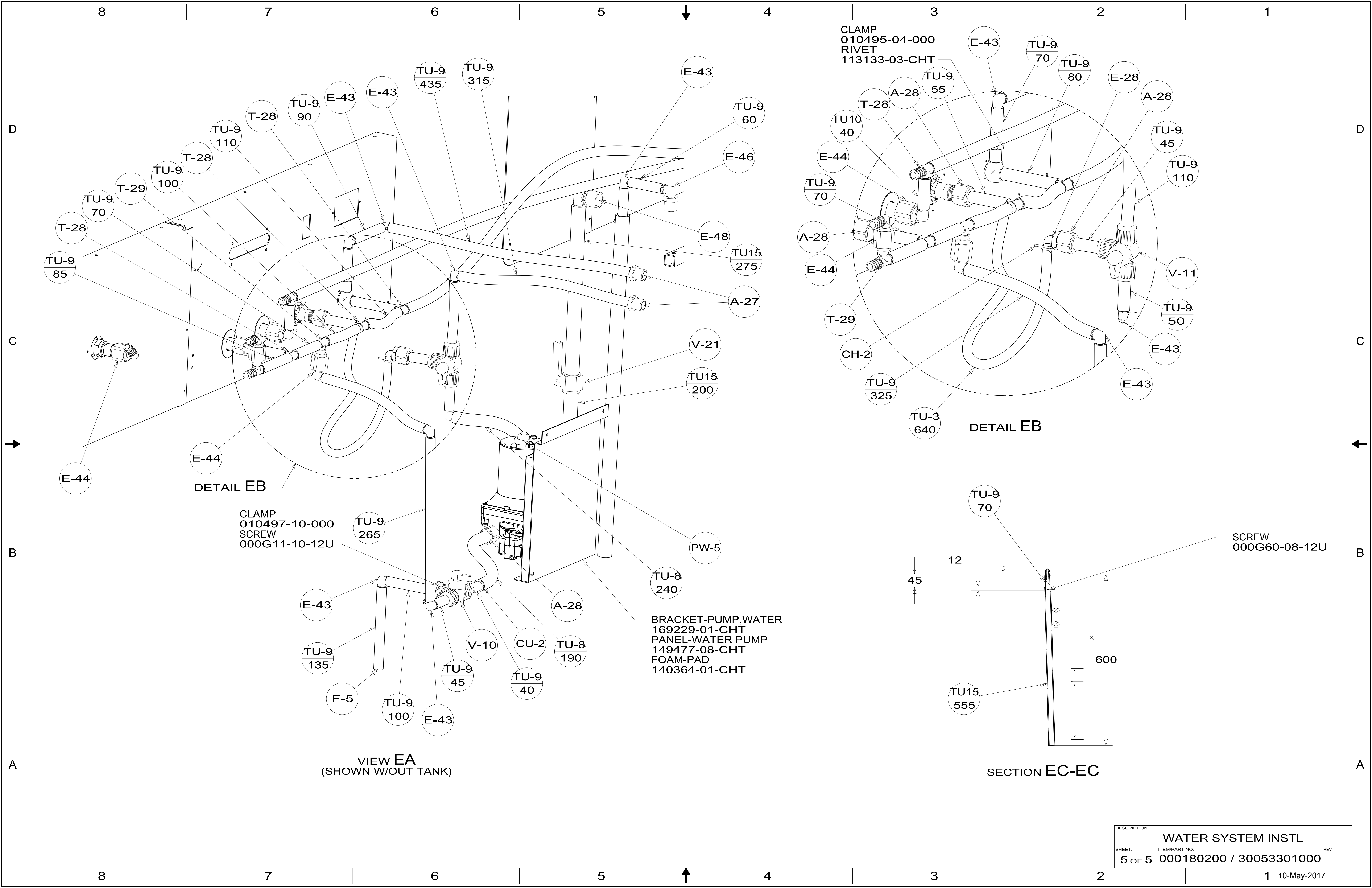

VIEW EA
(SHOWN W/OUT TANK)

DETAIL EB

SECTION EC-EC

CLAMP
010497-10-000
SCREW
000G11-10-12U

BRACKET-PUMP, WATER
169229-01-CHT
PANEL-WATER PUMP
149477-08-CHT
FOAM-PAD
140364-01-CHT

CLAMP
010495-04-000
RIVET
113133-03-CHT

SCREW
000G60-08-12U

DESCRIPTION:		
WATER SYSTEM INSTL		
SHEET:	ITEM/PART NO:	REV
5 OF 5	000180200 / 30053301000	