

8 7 6 5 4 3 2 1

D

D

C

C

B

B

A

A

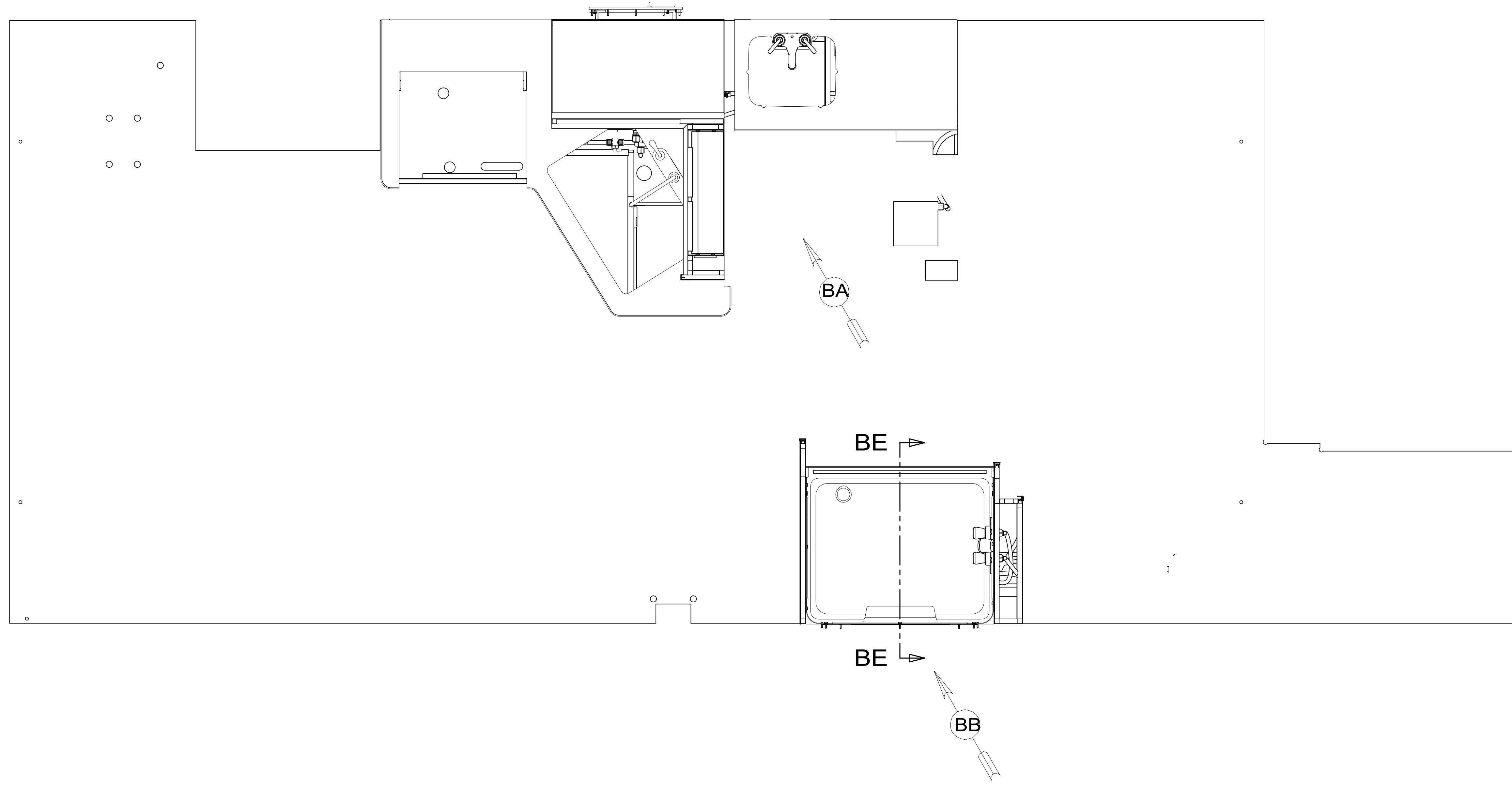

- 8. ALL CRIMP FITTINGS TO PEX TUBING REQUIRE 1/2" CLAMP 140171-03-000.
- 7. ALL CRIMP FITTINGS TO PEX TUBING REQUIRE 5/8" CLAMP 140171-04-000.
- 6 LABEL HOT AND COLD SUPPLY TUBES AND TAPE FITTING TO TUBE BEFORE CABINET SET TO PREVENT MOVEMENT.
- 5 ADD PIPE WRAP (LADDER SCRAP 110157-02-000) INSULATION.
- 4 ADD TEFLON TAPE 010405-02-000.
- 3. ALL TUBING TO BE SECURED AT 1200 INTERVALS MAXIMUM WITH CLAMP 010495-01-000 AND SCREW 000G67-10-12U OR EQUIVALENT.
- 2. TUBING TO BE INSTALLED WITH SUFFICIENT SLOPE TO PROVIDE DRAINAGE TO NEAREST VALVE.
- 1. PLASTIC FITTINGS TO BE SEALED WITH SEALANT 084456-01-000.

NOTES:

X-X
 FOR WATER CALLOUTS SEE DWG NO. 303369-01-000

WINNEBAGO [®]		
COPYRIGHT 2017 WINNEBAGO INDUSTRIES, INC.		
DSNR:		ALL DIMENSIONS ARE IN MILLIMETERS
DIFFR:		⊕
UNSPECIFIED TOLERANCES:		MATERIAL:
WHOLE DIM (X) :	3	
ONE-PLACE (X.X) :	1.5	
TWO-PLACE (X.XX) :	0.50	
ANGLE :	1°	
REFER TO ES0018 FOR FASTENER TIGHTENING GUIDELINES		WEIGHT: (LBS) FIRST USED: (REF)
		16 E26HE
DESCRIPTION:		
WATER SYSTEM INSTL		
SHEET:	ITEM/PART NO.:	REV
1 OF 4	000179683 / 30053701000	
REF:		1 11-May-2017

8 7 6 5 4 3 2 1

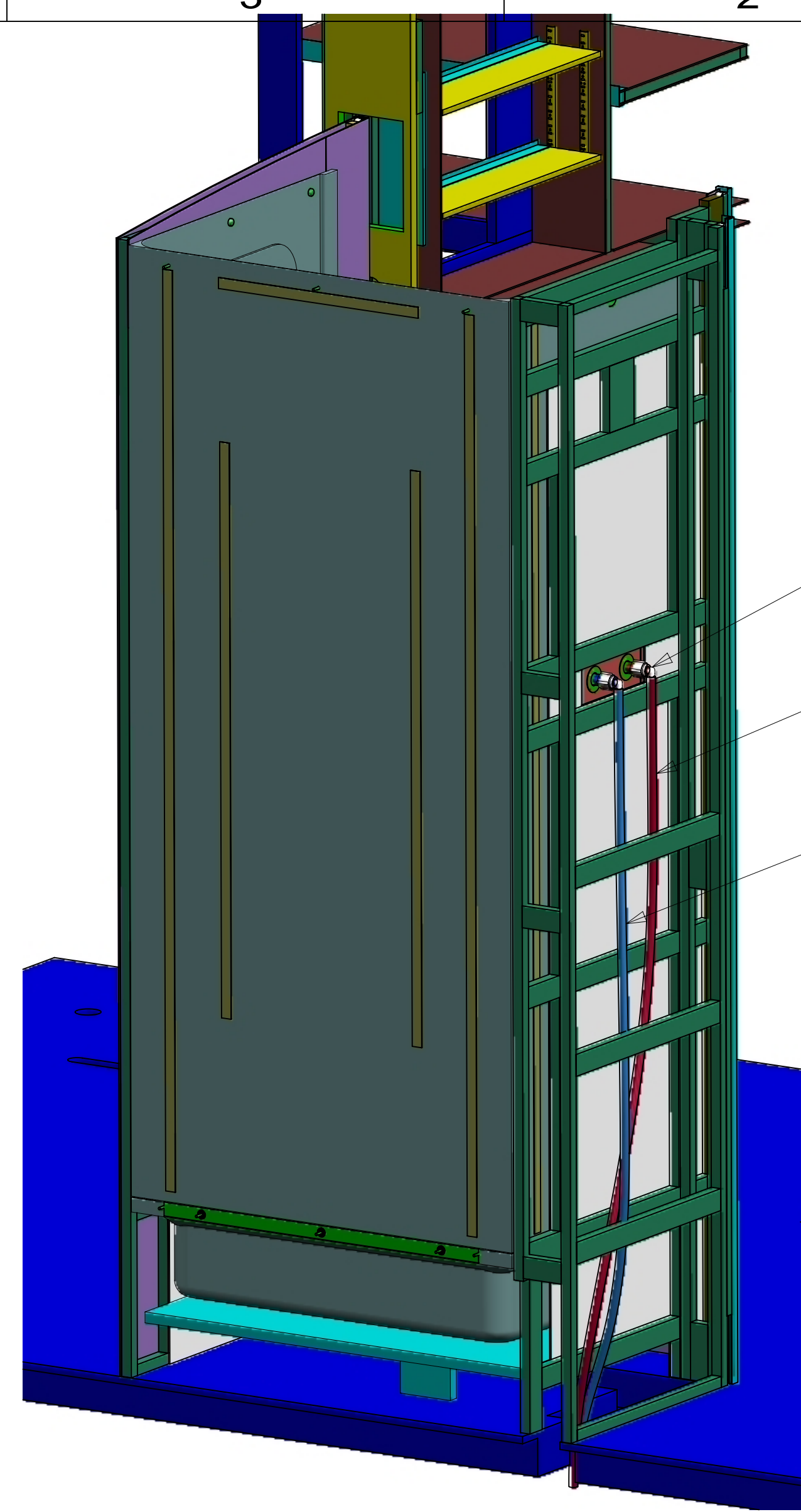
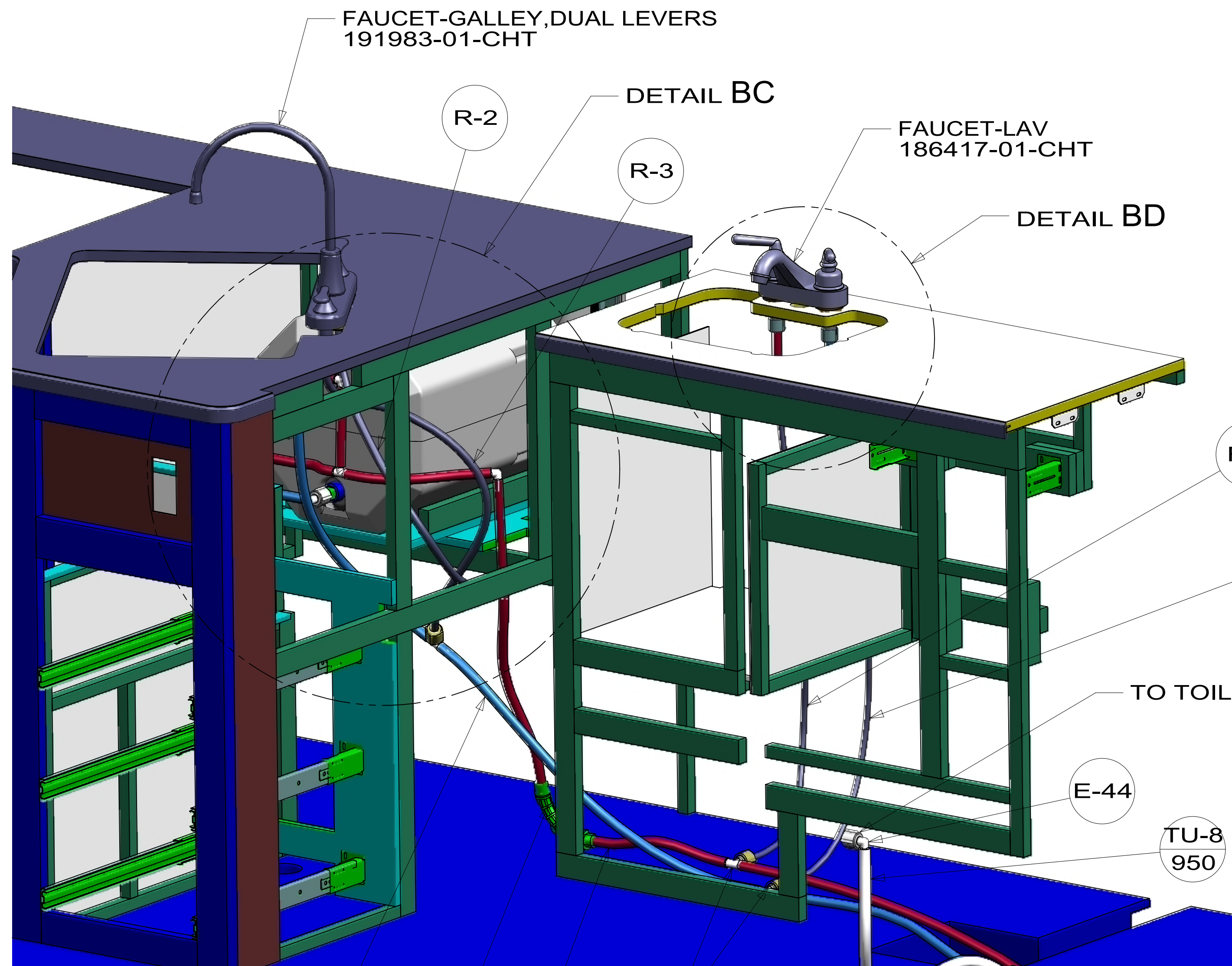

VIEW BB

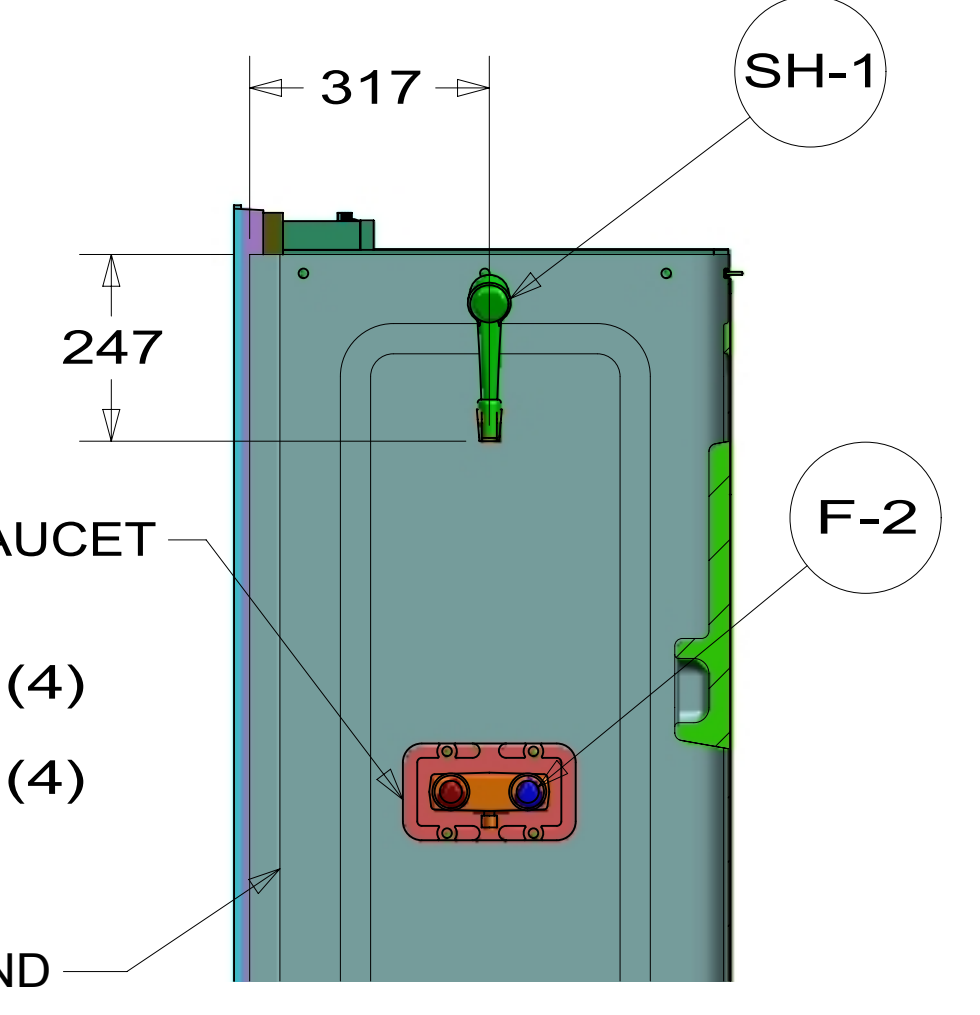

SECTION BE-BE

VIEW BA

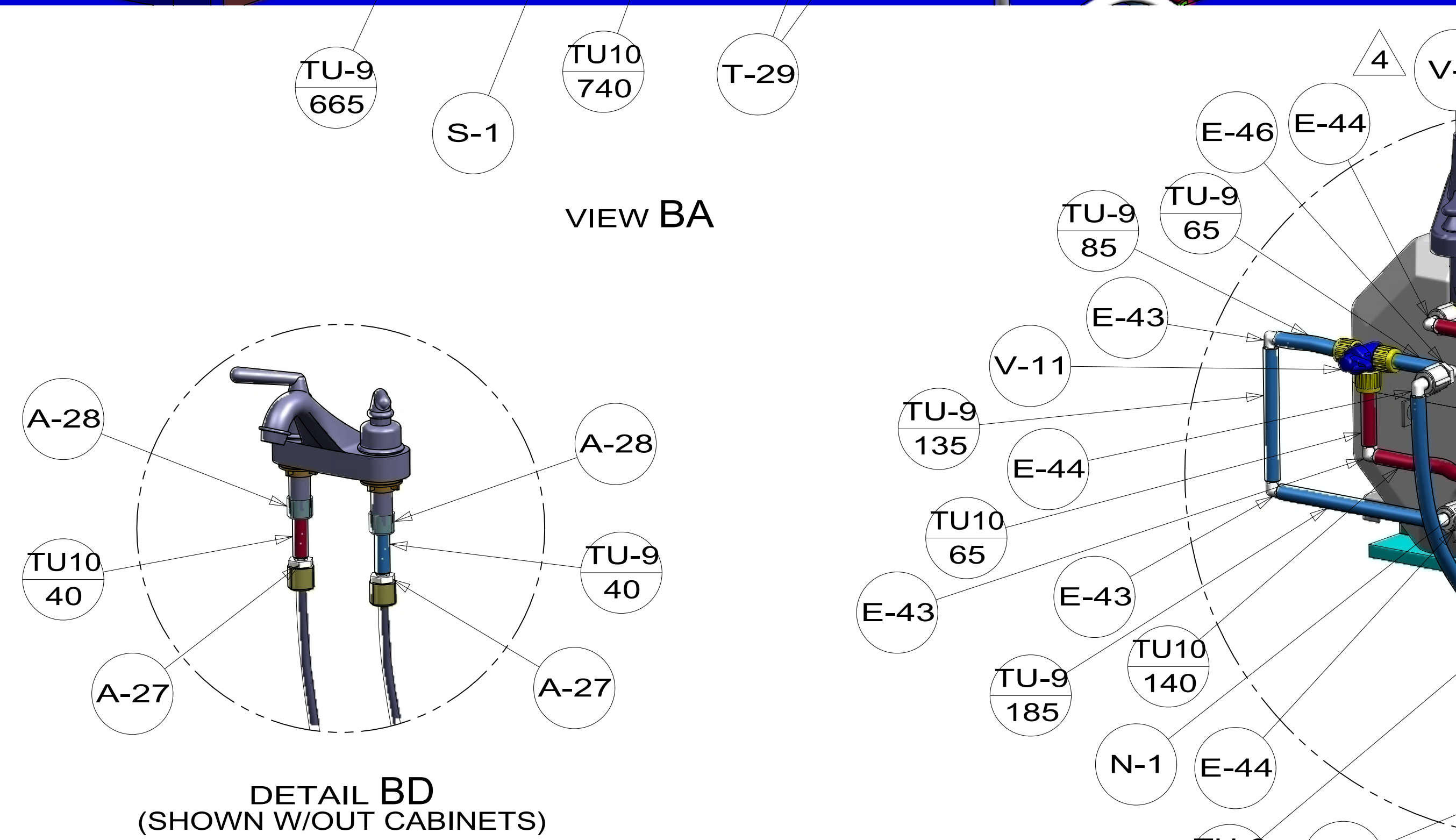

DETAIL BC (SHOWN W/OUT CABINETS & FAUCET)

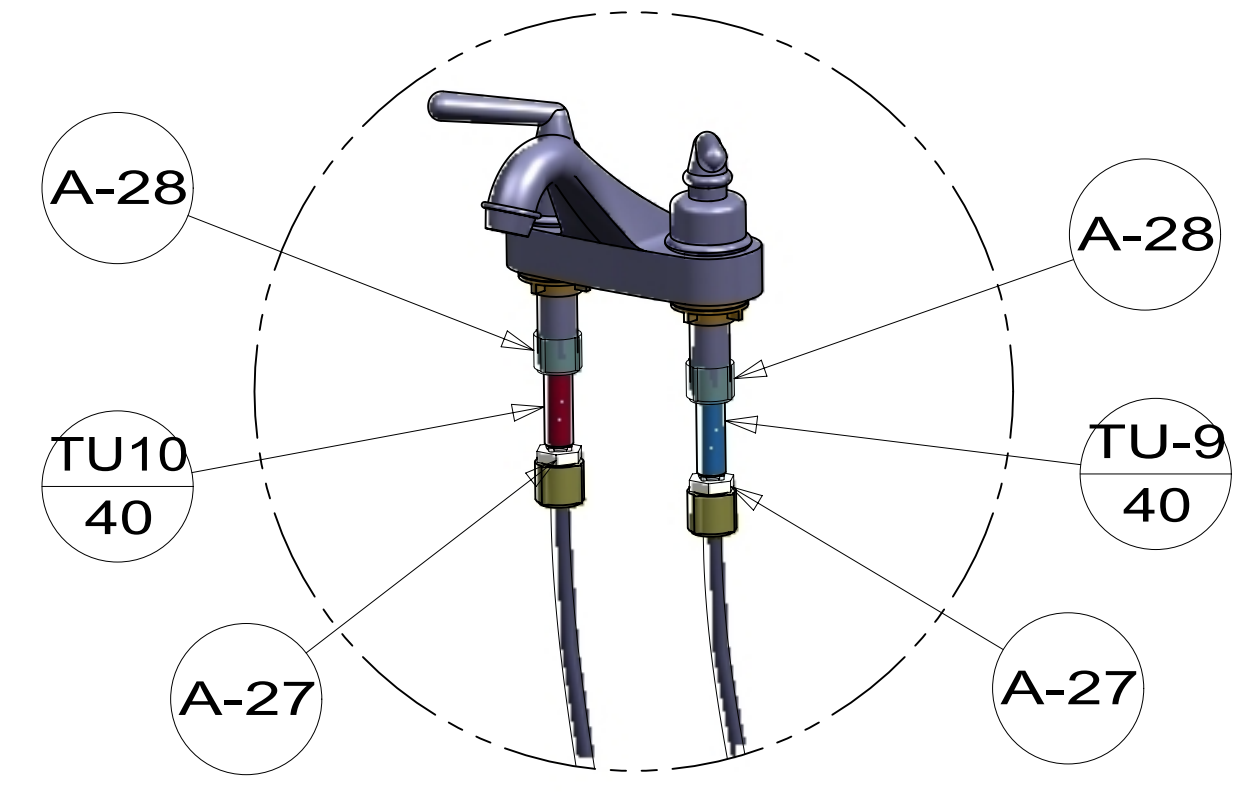

DETAIL BD (SHOWN W/OUT CABINETS)

- WATER HEATER INSTL-6 GAL 186899-04-000
- CABLE 076767-03-000
- SCREW 000G11-06-08U (2)
- BUMPER-RUBBER 120863-05-000 (2)
- SCREW 000G39-06-10U (2)

PLATFORM ASM 184166-01-000

- PANEL-SHOWER FAUCET 167738-02-CHT
- COVER-SCREW 166569-01-CHT (4)
- SCREW 000G11-08-12U (4)

SHOWER SURROUND (REF)

DESCRIPTION:		
WATER SYSTEM INSTL		
SHEET:	ITEM/PART NO.:	REV
2 OF 4	000179683 / 30053701000	

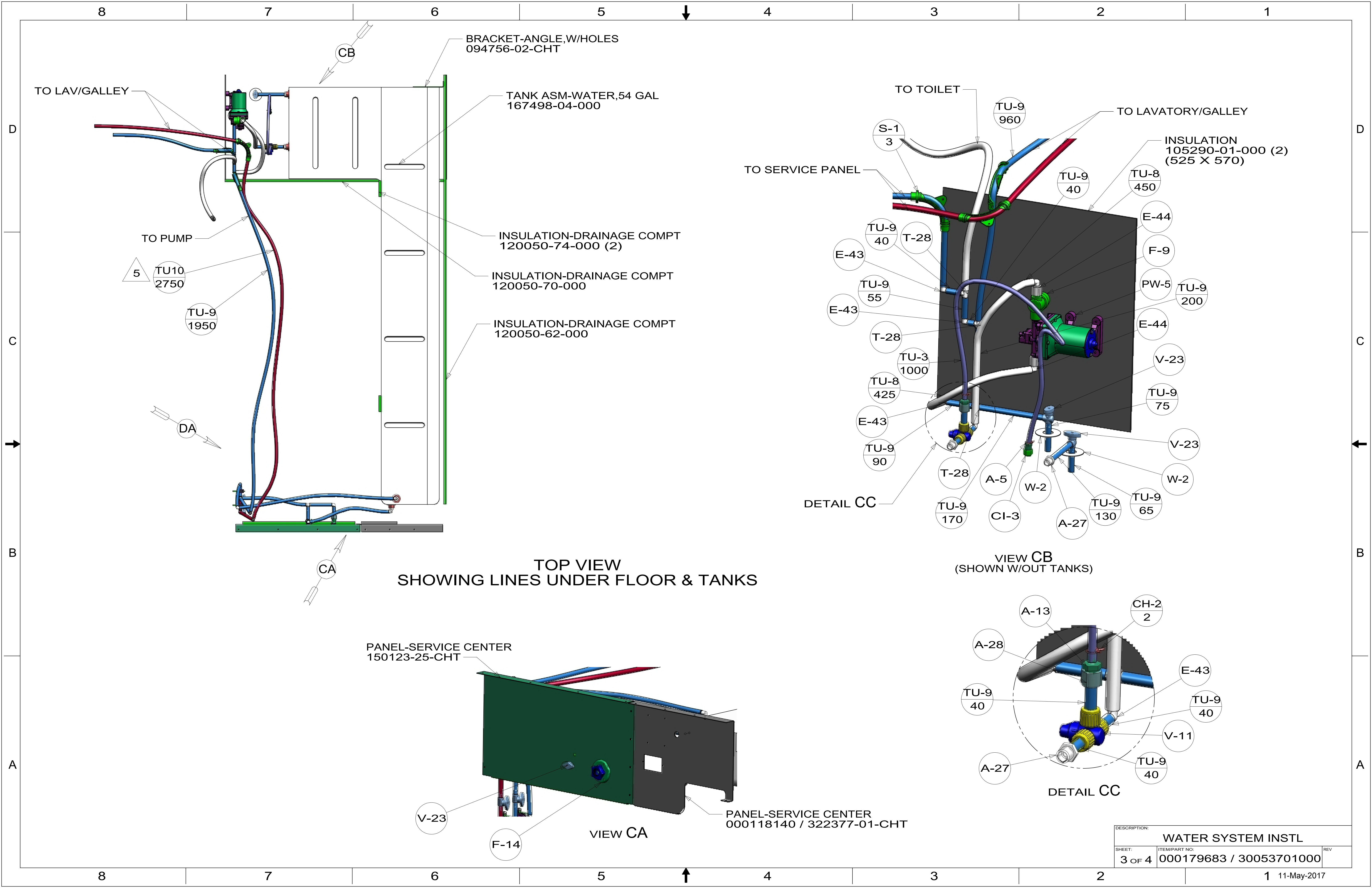

8 7 6 5 4 3 2 1

D
C
B
A

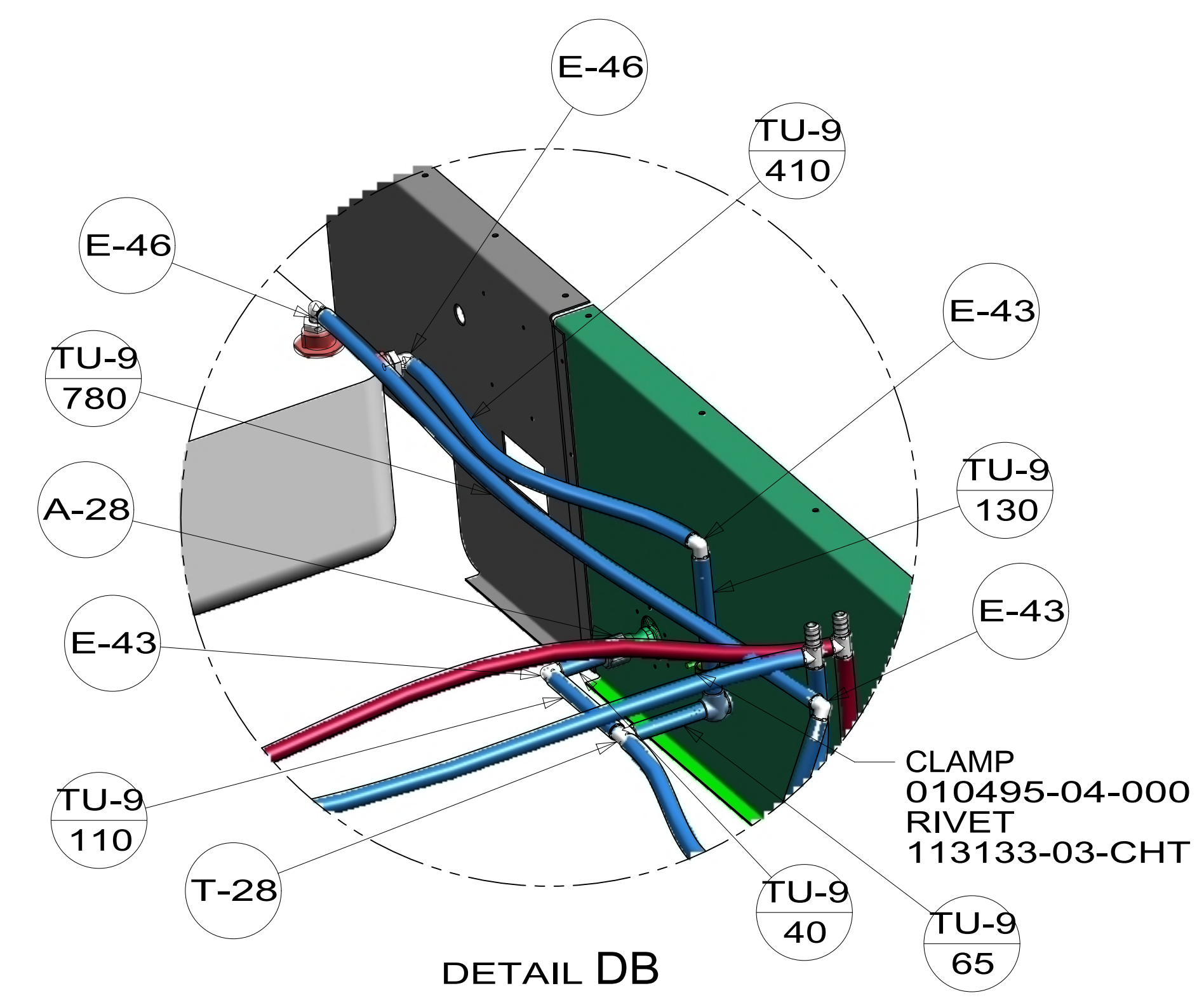
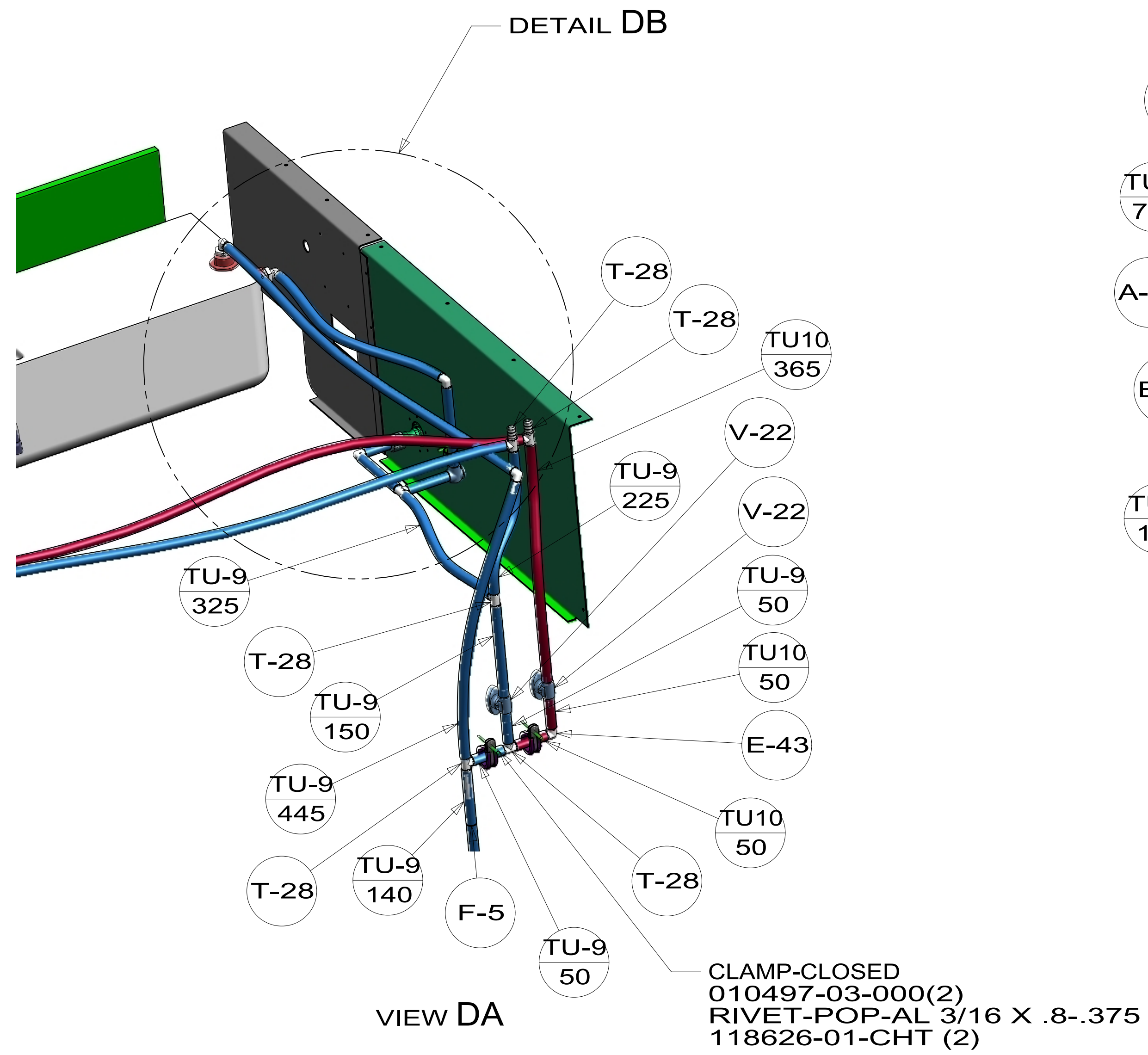

DESCRIPTION:		
WATER SYSTEM INSTL		
SHEET:	ITEM/PART NO:	REV
4 OF 4	000179683 / 30053701000	

8 7 6 5 4 3 2 1 11-May-2017