

8 7 6 5 4 3 2 1

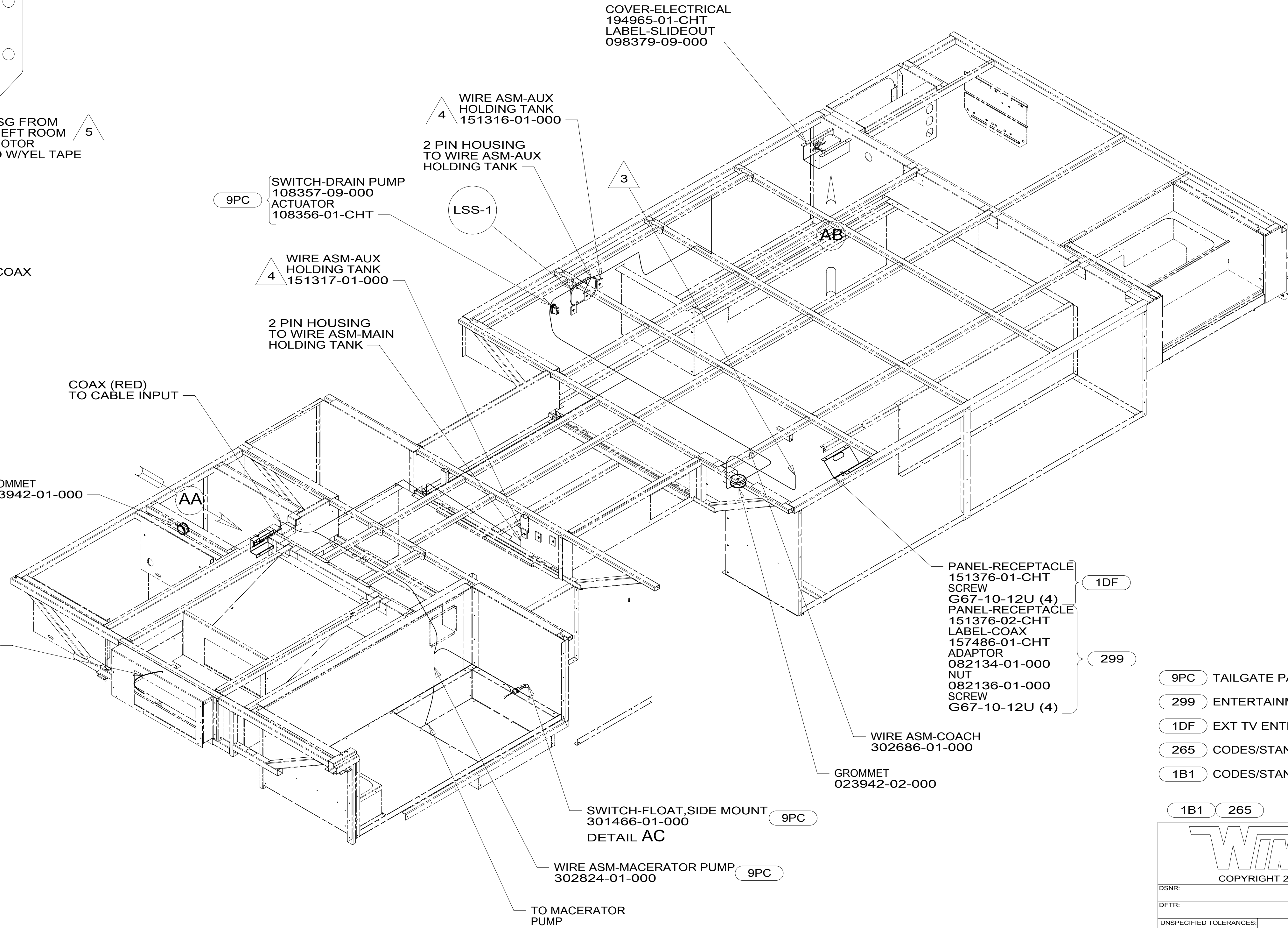

- 6 ARROW POINTS UPWARD AFTER SWITCH IS INSTALLED. FITTING TO BE SEALED WITH SEALANT 084456-01-000.
- 5 WIRES ARE PART OF WIRE ASM-CHASSIS.
- 4 PLACE CROSS LOCATOR ON SENSORS OVER DIMPLES ON TANK.
- 3 WIRE PASSES THROUGH FLOOR IN THIS AREA.
2. ROUTE TANK SENSOR WIRES SO THEY DO NOT PASS OVER SENSORS. USE WIRE TIE MOUNT 155366-01-000 AND WIRE TIE 8343-01-000 AS NEEDED. TANK SURFACE MUST BE CLEANED USING ISOPROPYL ALCOHOL AND PRIMED WITH PRIMER 94.
1. ALL WIRES TO BE SECURED WITH CLAMP 10495 OR 10497 OR WIRE TIE 8343 OR 108046 EVERY 600MM, USE SCREW G67-XX-XXX OR G56-XX-XXX AS APPROPRIATE FOR INSTALLATION.

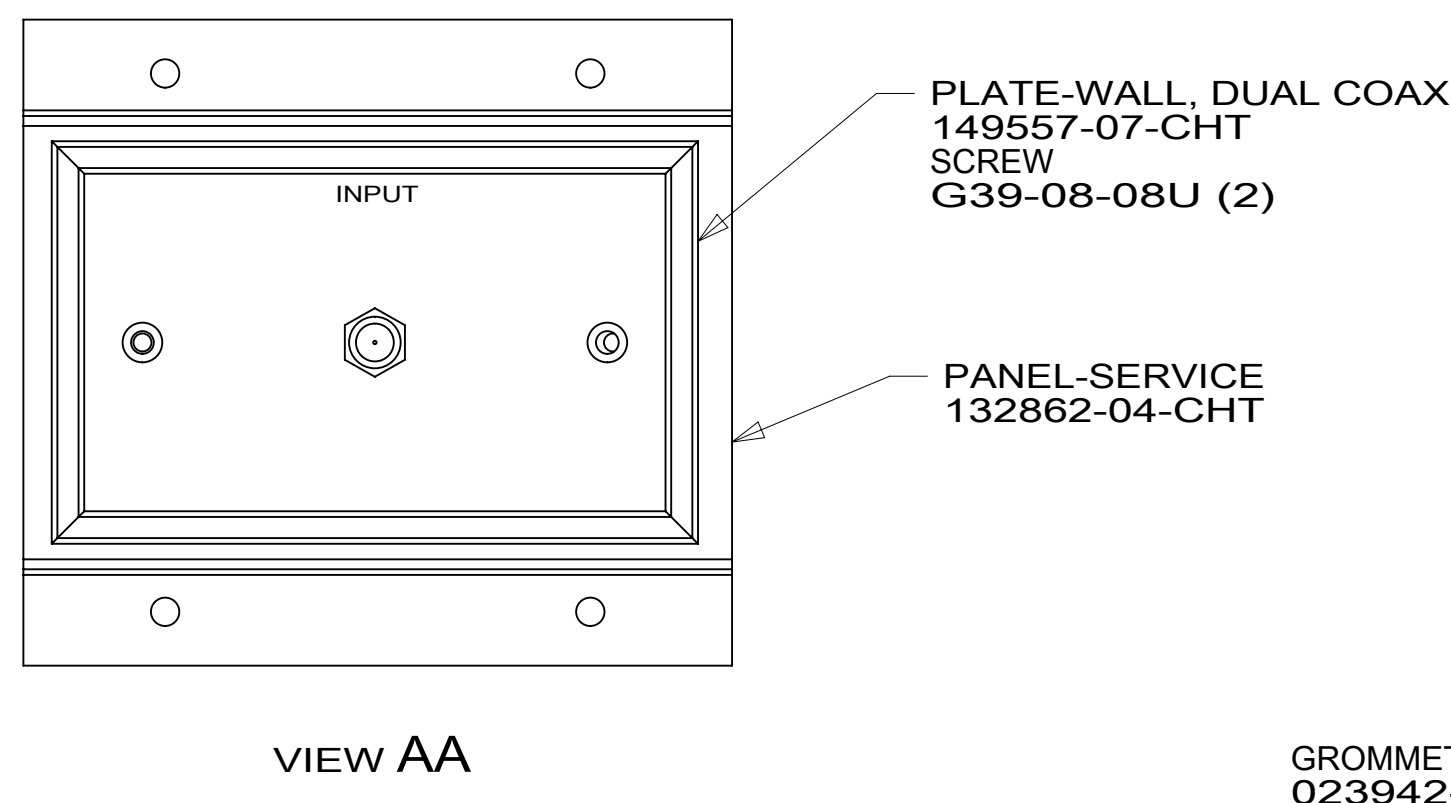
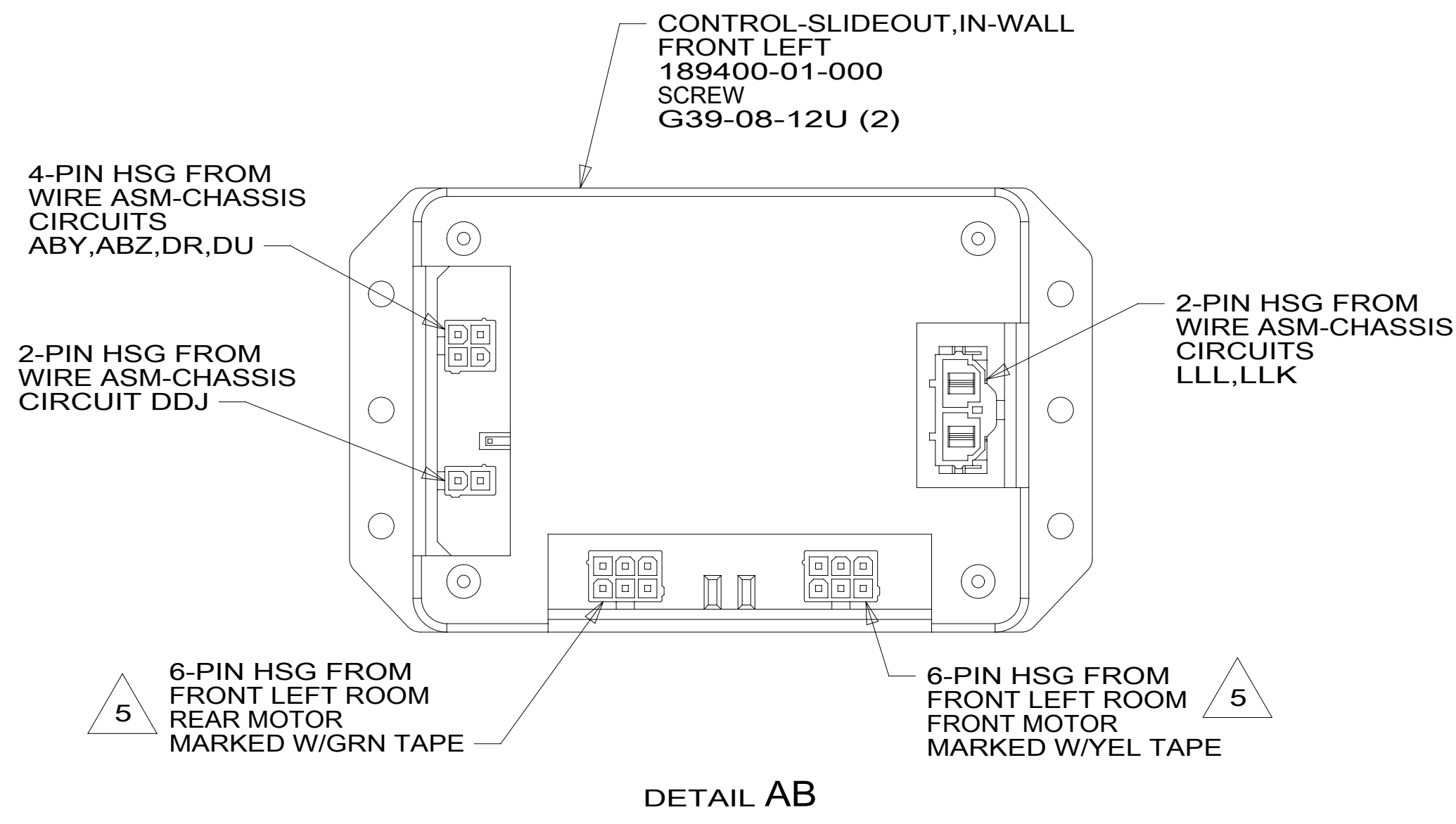
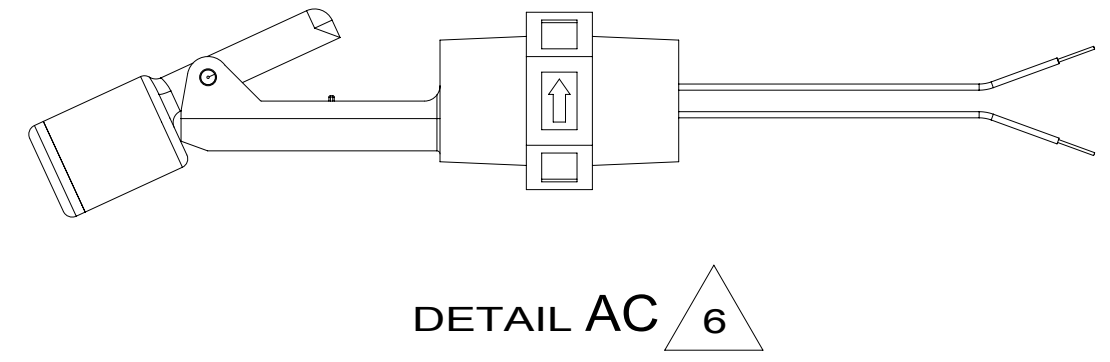

FOR ELECTRICAL TORQUE SPECIFICATIONS SEE DWG NO. 128783-01-000

FOR ELECTRICAL CALLOUTS SEE DWG NO. 121339-01-000

- 9PC TAILGATE PACKAGE
- 299 ENTERTAINMENT CENTER EXT.W/O
- 1DF EXT TV ENTERTAINMENT CENTER
- 265 CODES/STANDARDS-CSA/CMVSS
- 1B1 CODES/STANDARDS USA

WINNEBAGO
COPYRIGHT 2016 WINNEBAGO INDUSTRIES, INC.

DSNR:	ALL DIMENSIONS ARE IN MILLIMETERS	
DIFFR:	MATERIAL:	
UNSPECIFIED TOLERANCES:		
WHOLE DIM (X) :	3	
ONE-PLACE (X.X) :	1.5	
TWO-PLACE (X.XX) :	0.50	
ANGLE :	1°	
REFER TO ES0018 FOR FASTENER TIGHTENING GUIDELINES	WEIGHT: (LBS)	FIRST USED:
		17 E29VE
DESCRIPTION:		
WIRING INSTL-BODY, 12V		
SHEET:	ITEM/PART NO.:	REV:
1 OF 6	000178092 / 30243701000	
REF:		1 14-Sep-2017

8 7 6 5 4 3 2 1

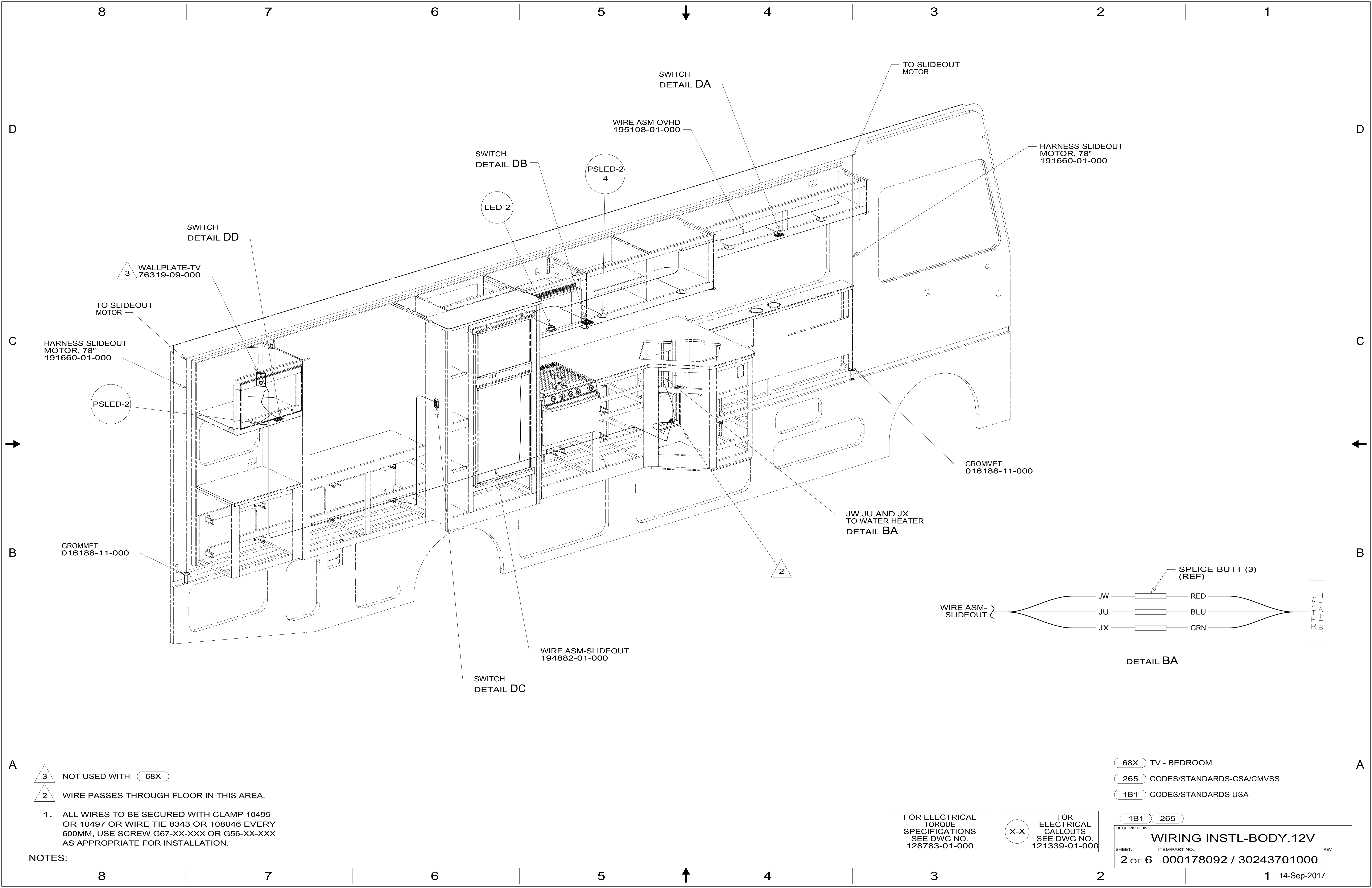

3 NOT USED WITH 68X

2 WIRE PASSES THROUGH FLOOR IN THIS AREA.

1. ALL WIRES TO BE SECURED WITH CLAMP 10495 OR 10497 OR WIRE TIE 8343 OR 108046 EVERY 600MM, USE SCREW G67-XX-XXX OR G56-XX-XXX AS APPROPRIATE FOR INSTALLATION.

NOTES:

- 68X TV - BEDROOM
- 265 CODES/STANDARDS-CSA/CMVSS
- 1B1 CODES/STANDARDS USA

FOR ELECTRICAL TORQUE SPECIFICATIONS SEE DWG NO. 128783-01-000

FOR ELECTRICAL CALLOUTS SEE DWG NO. 121339-01-000

DESCRIPTION:		1B1 265
WIRING INSTL-BODY, 12V		
SHEET:	ITEM/PART NO.:	REV:
2 OF 6	000178092 / 30243701000	

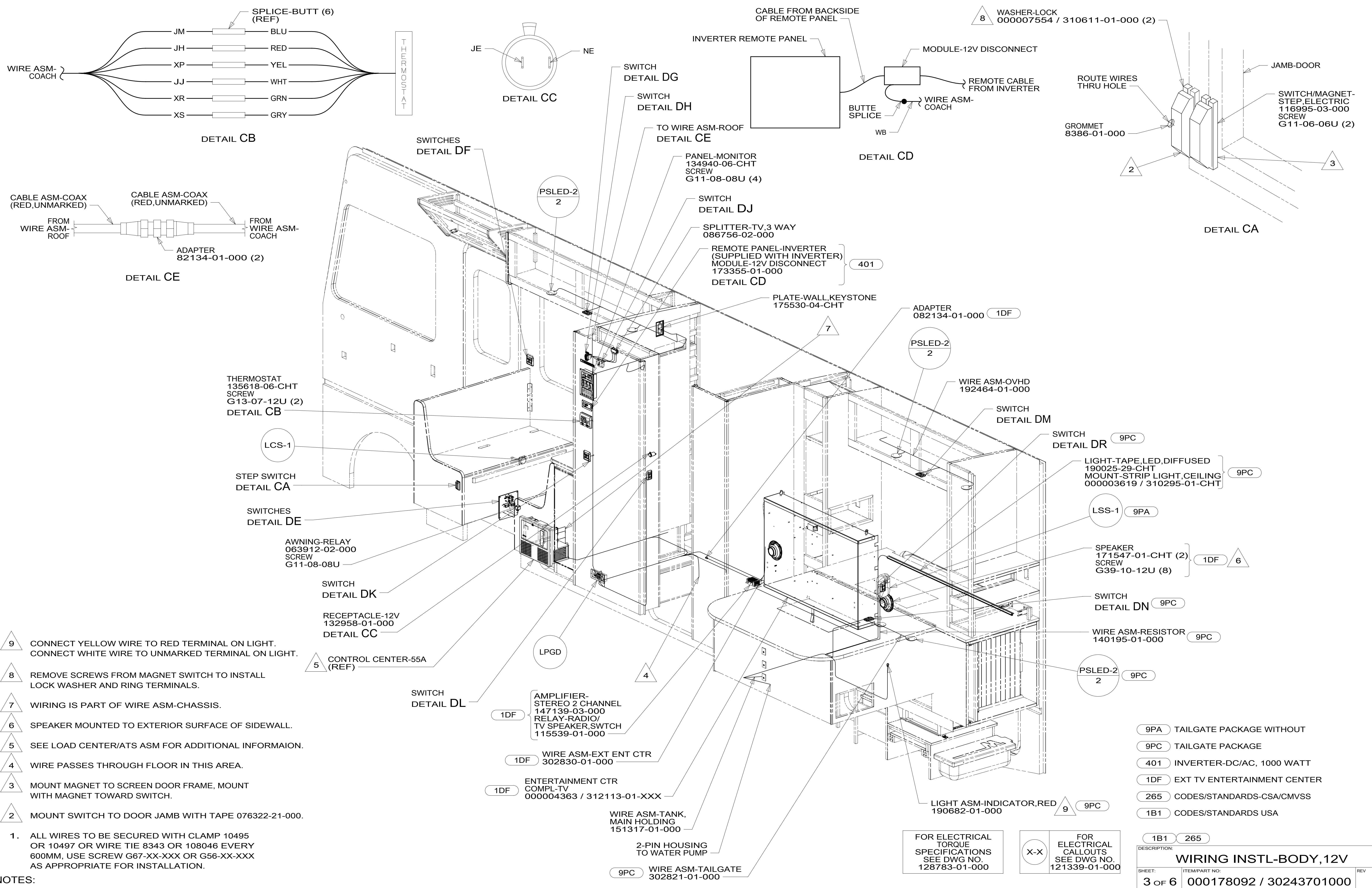

- 9 CONNECT YELLOW WIRE TO RED TERMINAL ON LIGHT. CONNECT WHITE WIRE TO UNMARKED TERMINAL ON LIGHT.
- 8 REMOVE SCREWS FROM MAGNET SWITCH TO INSTALL LOCK WASHER AND RING TERMINALS.
- 7 WIRING IS PART OF WIRE ASM-CHASSIS.
- 6 SPEAKER MOUNTED TO EXTERIOR SURFACE OF SIDEWALL.
- 5 SEE LOAD CENTER/ATS ASM FOR ADDITIONAL INFORMATION.
- 4 WIRE PASSES THROUGH FLOOR IN THIS AREA.
- 3 MOUNT MAGNET TO SCREEN DOOR FRAME, MOUNT WITH MAGNET TOWARD SWITCH.
- 2 MOUNT SWITCH TO DOOR JAMB WITH TAPE 076322-21-000.

1. ALL WIRES TO BE SECURED WITH CLAMP 10495 OR 10497 OR WIRE TIE 8343 OR 108046 EVERY 600MM, USE SCREW G67-XX-XXX OR G56-XX-XXX AS APPROPRIATE FOR INSTALLATION.

NOTES:

- 9PA TAILGATE PACKAGE WITHOUT
- 9PC TAILGATE PACKAGE
- 401 INVERTER-DC/AC, 1000 WATT
- 1DF EXT TV ENTERTAINMENT CENTER
- 265 CODES/STANDARDS-CSA/CMVSS
- 1B1 CODES/STANDARDS USA

FOR ELECTRICAL TORQUE SPECIFICATIONS SEE DWG NO. 128783-01-000

FOR ELECTRICAL CALLOUTS SEE DWG NO. 121339-01-000

DESCRIPTION:		
WIRING INSTL-BODY, 12V		
SHEET:	ITEM/PART NO.:	REV:
3 OF 6	000178092 / 30243701000	

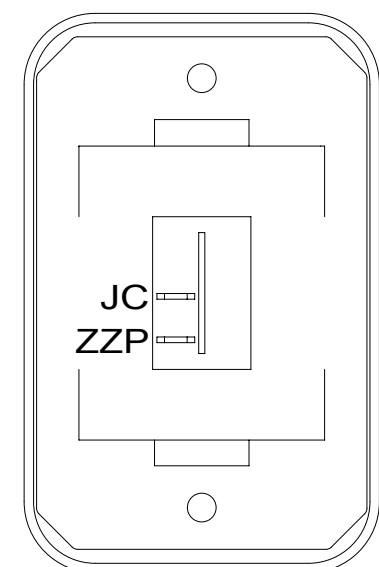

SWITCH-ROCKER
135740-01-CHT
SWITCH-BASE
135741-01-CHT
SWITCH-BEZEL
135742-01-CHT
SCREW
G11-08-08U (2)

DETAIL DA

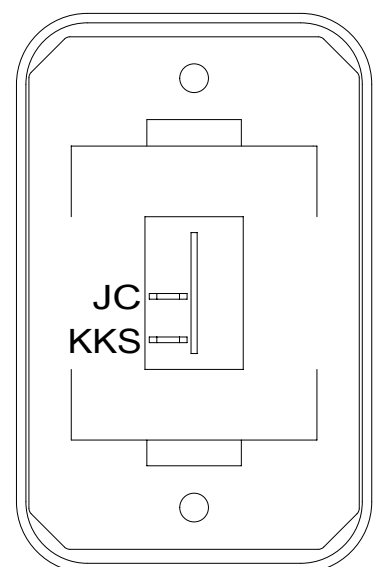

SWITCH-ROCKER
135740-01-CHT
SWITCH-BASE
135741-01-CHT
SWITCH-BEZEL
135742-01-CHT
SCREW
G11-08-08U (2)

DETAIL DD

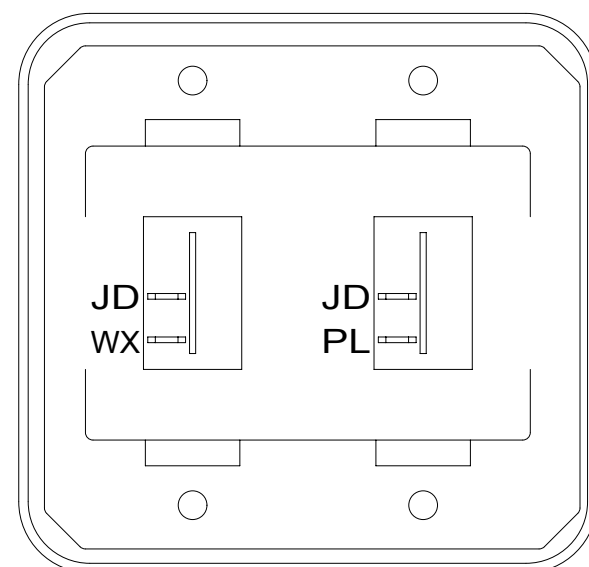

SWITCH-ROCKER
135740-01-CHT (2)
SWITCH-BASE
135741-02-CHT
SWITCH-BEZEL
135742-02-CHT
SCREW
G11-08-08U (4)

DETAIL DK

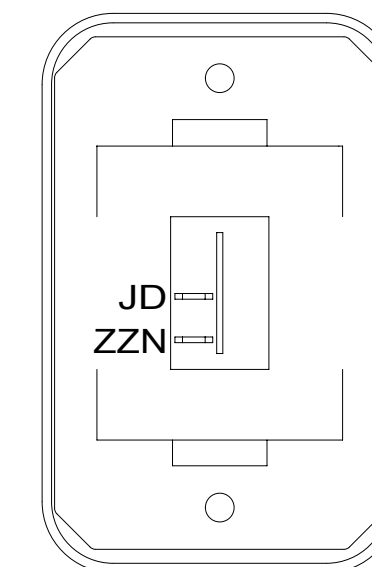

SWITCH-ROCKER
135740-01-CHT
SWITCH-BASE
135741-01-CHT
SWITCH-BEZEL
135742-01-CHT
SCREW
G11-08-08U (2)

DETAIL DN 9PC

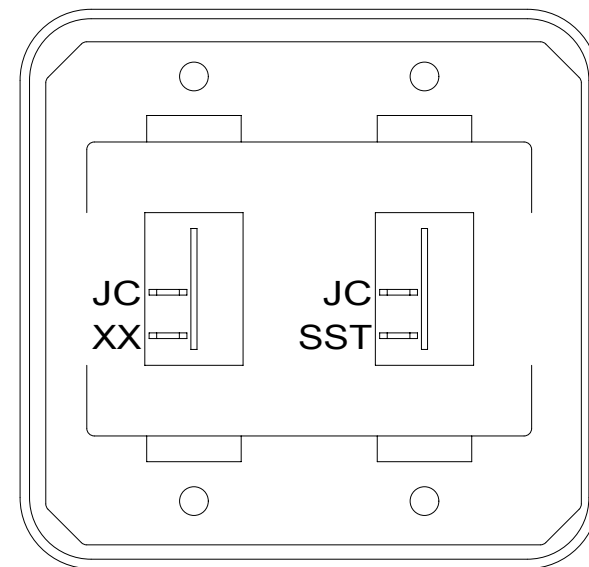

SWITCH-ROCKER
135740-01-CHT (2)
SWITCH-BASE
135741-02-CHT
SWITCH-BEZEL
135742-02-CHT
SCREW
G11-08-08U (4)

DETAIL DB

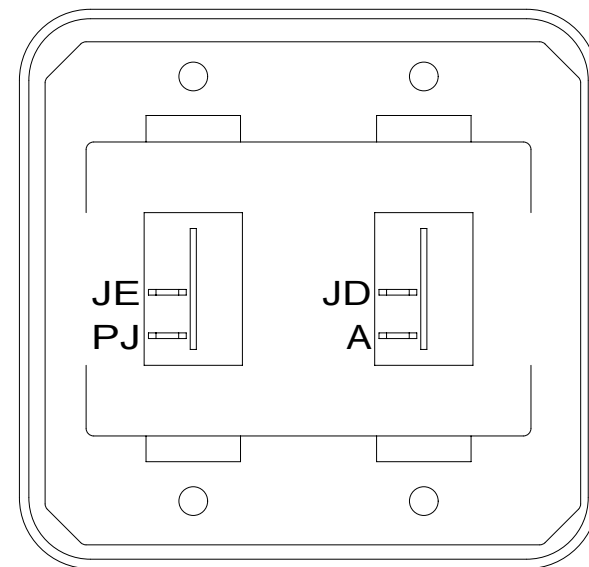

SWITCH-ROCKER
135740-01-CHT (2)
SWITCH-BASE
135741-02-CHT
SWITCH-BEZEL
135742-02-CHT
SCREW
G11-08-08U (4)

DETAIL DF

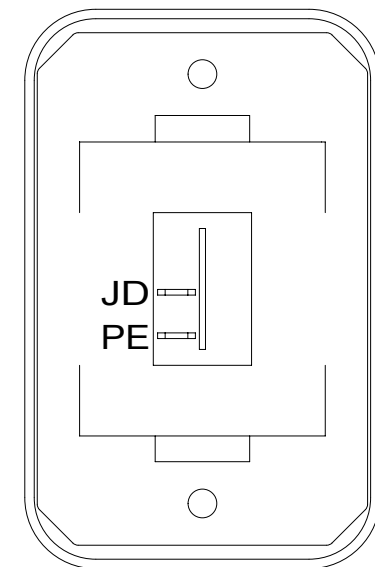

SWITCH-ROCKER
135740-01-CHT
SWITCH-BASE
135741-01-CHT
SWITCH-BEZEL
135742-01-CHT
SCREW
G11-08-08U (2)

DETAIL DL

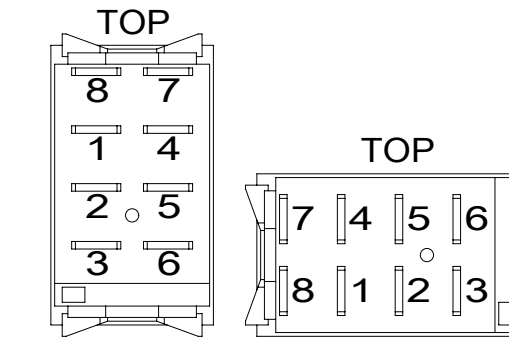

DETAIL DP

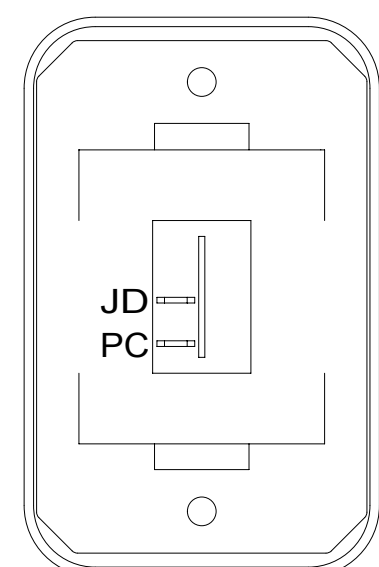

SWITCH-ROCKER
135740-01-CHT
SWITCH-BASE
135741-01-CHT
SWITCH-BEZEL
135742-01-CHT
SCREW
G11-08-08U (2)

DETAIL DC

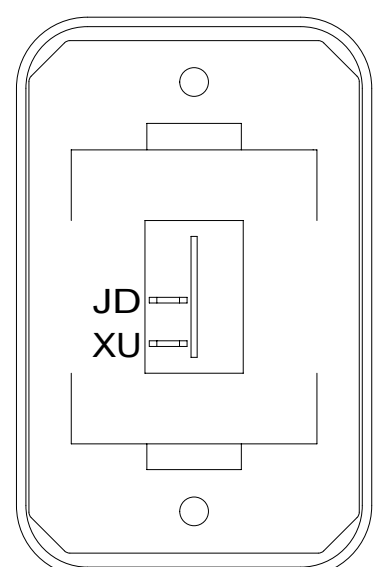

SWITCH-ROCKER
135740-01-CHT
SWITCH-BASE
135741-01-CHT
SWITCH-BEZEL
135742-01-CHT
SCREW
G11-08-08U (2)

DETAIL DG

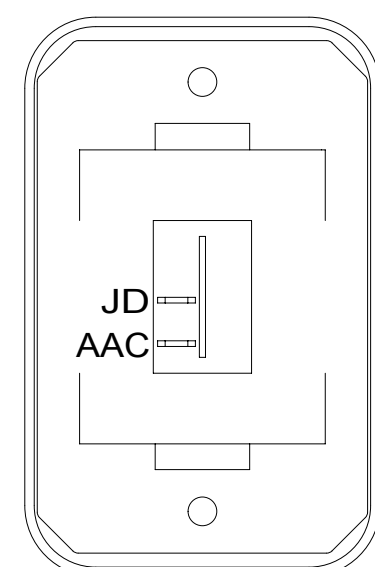

SWITCH-ROCKER
135740-01-CHT
SWITCH-BASE
135741-01-CHT
SWITCH-BEZEL
135742-01-CHT
SCREW
G11-08-08U (2)

DETAIL DM

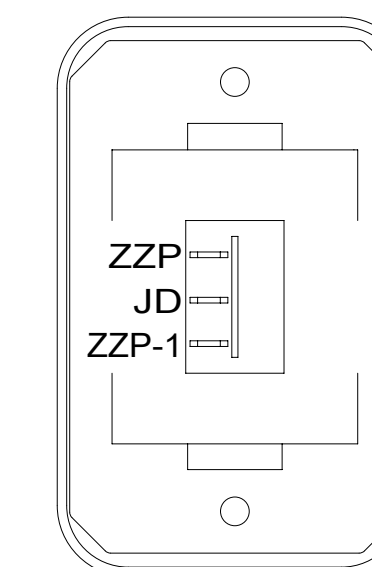

SWITCH-ROCKER
135740-04-CHT
SWITCH-BASE
135741-01-CHT
SWITCH-BEZEL
135742-01-CHT
SCREW
G11-08-08U (2)

DETAIL DR

SWITCH-AWNING
108357-06-000
ACTUATOR-SWITCH
108356-12-CHT
CIRCUITS
FFD,FFR,FFE
FFE,JJR,FFD

SWITCH-AWNING
108357-14-000
ACTUATOR-SWITCH
108356-28-CHT
CIRCUITS
SP,ZZL,WE,ZZL

SWITCH-COACH BATTERY
108357-18-000
ACTUATOR-SWITCH
108356-19-CHT
CIRCUITS
KF,LG,LJ-1,LH,WC
WIRE ASM-THERM
186796-01-000

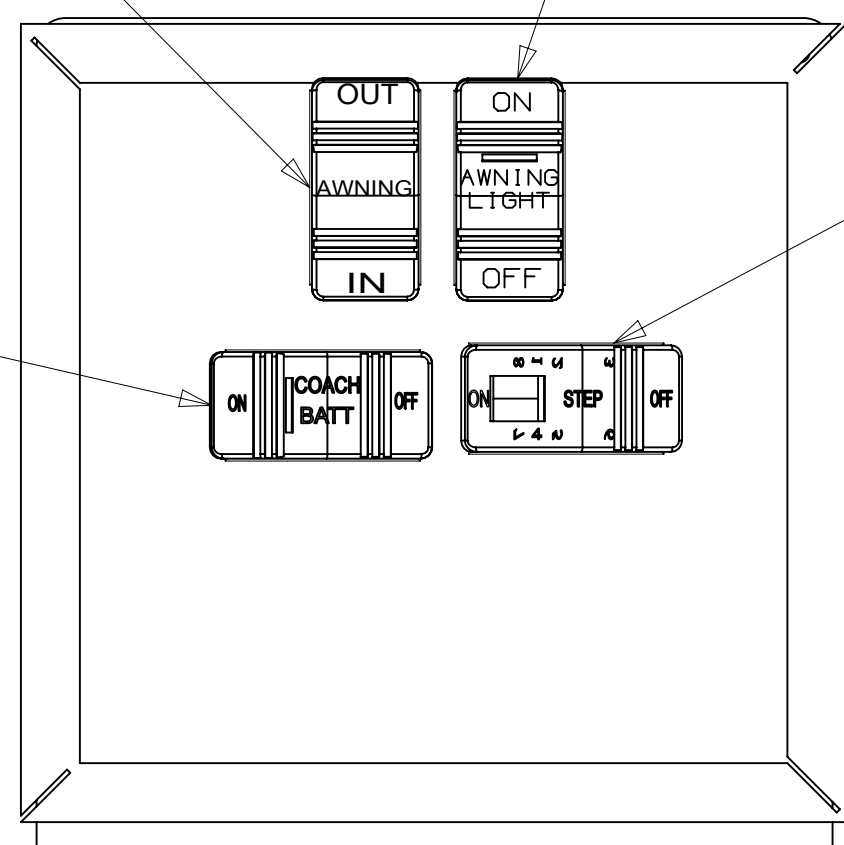

DETAIL DE 1

SWITCH-STEP
108357-19-000
CIRCUITS ER,ES

PLATE-SWITCH
302597-01-CHT
SEAL-FUSE BOX
092492-25-000
SCREW
G11-06-10U (6)

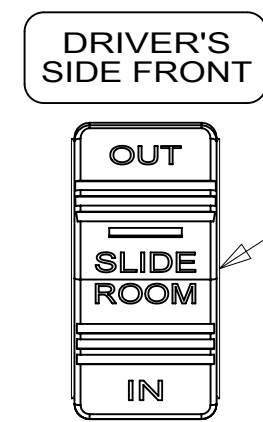

DETAIL DH

LABEL-SLIDEOUT,
DRIVER,FRONT
163992-01-CHT

SWITCH
108357-18-000
ACTUATOR
108356-31-CHT
CIRCUITS
DR,KE,DU
ABY,ABZ

LABEL-WARNING,
SLIDEOUT
116549-01-000

WARNING CRUSH HAZARD. Keep people and objects clear of the inside and the outside of the slideout room when operating. Failure to comply could result in death or serious injury.

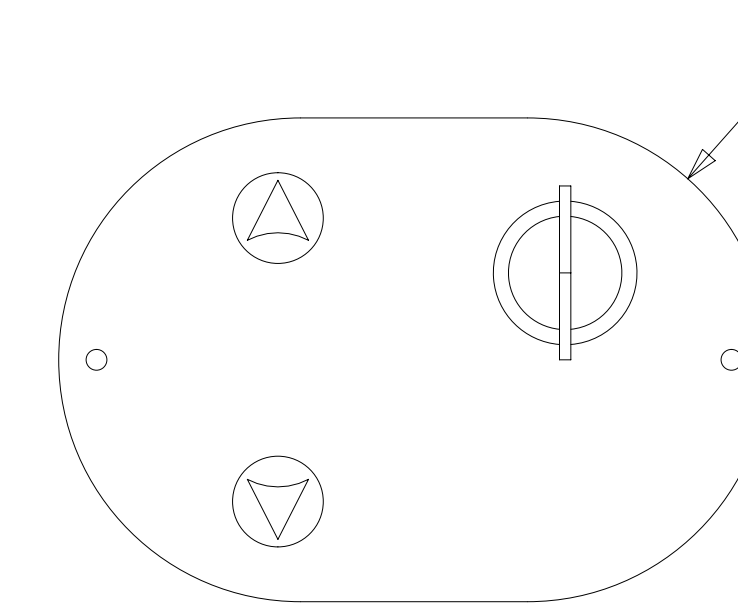

DETAIL DJ 45B

SWITCH-CONTROL
LOFT BED, TOUCH
189056-01-000
WIRE ASM-LOFT
BED SWITCH
000122806 / 323456-01-000
SCREW
000G11-02-08U (2)

2 PLACE AROUND ENTIRE PERIMETER WITH SEAM AT BOTTOM.

1 FOR SWITCH ORIENTATION SEE DETAIL DP.

NOTES:

9PC TAILGATE PACKAGE

45B LOFT BED

265 CODES/STANDARDS-CSA/CMVSS

1B1 CODES/STANDARDS USA

1B1 265

FOR ELECTRICAL
TORQUE
SPECIFICATIONS
SEE DWG NO.
128783-01-000

FOR ELECTRICAL
CALLOUTS
SEE DWG NO.
121339-01-000

DESCRIPTION:
WIRING INSTL-BODY, 12V

SHEET: 4 OF 6 ITEM/PART NO: 000178092 / 30243701000 REV

8 7 6 5 4 3 2 1



D

D

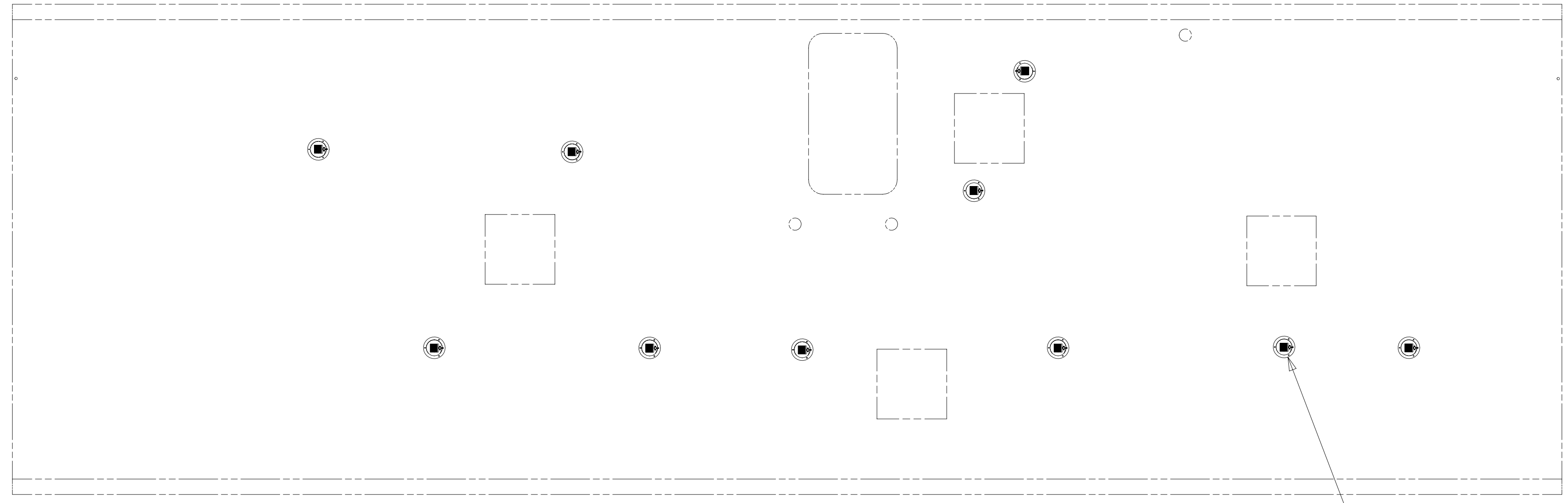

PRLED-4
10

C

C



B

B

A

A

8 7 6 5 4 3 2 1 14-Sep-2017

265 CODES/STANDARDS-CSA/CMVSS
1B1 CODES/STANDARDS USA

FOR ELECTRICAL TORQUE SPECIFICATIONS SEE DWG NO. 128783-01-000

FOR ELECTRICAL CALLOUTS SEE DWG NO. 121339-01-000

1B1 265

DESCRIPTION: **WIRING INSTL-BODY, 12V**

SHEET: 5 OF 6	ITEM/PART NO: 000178092 / 30243701000	REV
---------------	---------------------------------------	-----

8

7

6

5



4

3

2

1

D

D

C

C

B

B

A

A

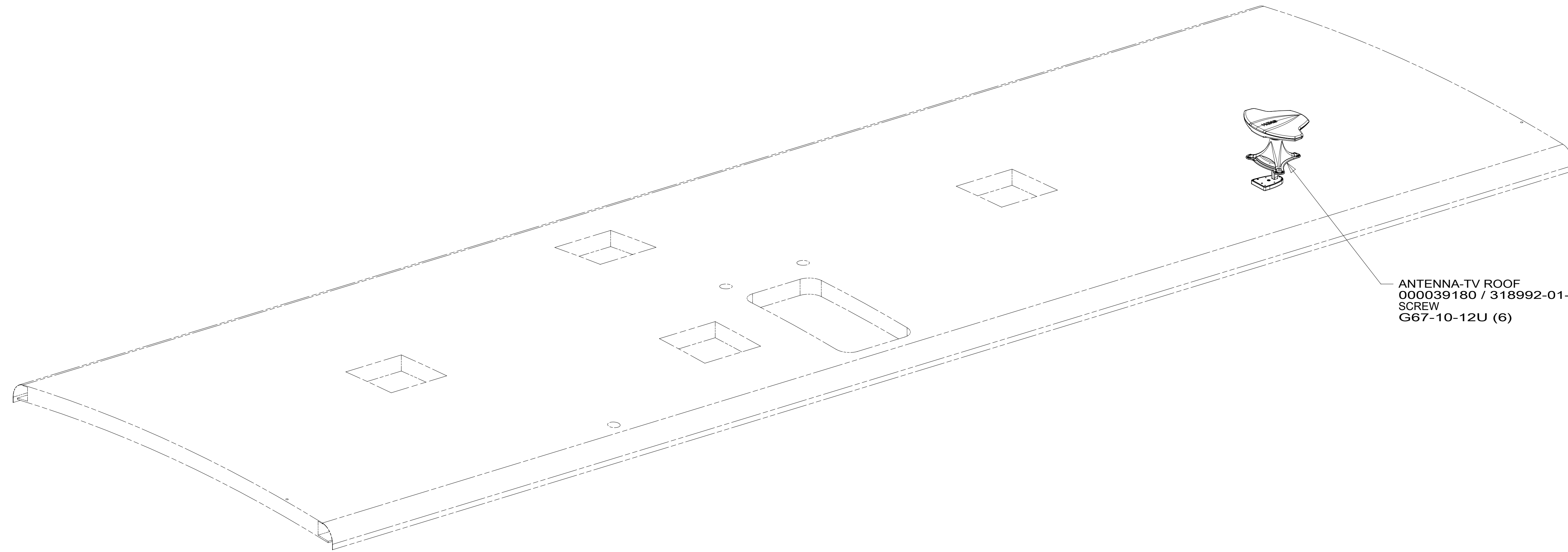

ANTENNA-TV ROOF
 000039180 / 318992-01-CHT
 SCREW
 G67-10-12U (6) 1

1 SEE ANTENNA INSTALLATION MANUAL FOR CORRECT
 INSTALLATION PROCEDURE.

NOTES:

FOR ELECTRICAL
 TORQUE
 SPECIFICATIONS
 SEE DWG NO.
 128783-01-000

FOR
 ELECTRICAL
 CALLOUTS
 SEE DWG NO.
 121339-01-000

- 265 CODES/STANDARDS-CSA/CMVSS
- 1B1 CODES/STANDARDS USA

1B1 265	
DESCRIPTION: WIRING INSTL-BODY, 12V	
SHEET:	ITEM/PART NO:
6 OF 6	000178092 / 30243701000

8

7

6

5



4

3

2

1 14-Sep-2017