

FROM WIRE ASM-CHASSIS
4 PIN HSG
CIRCUITS: ABY, ABZ, DR, DU

FROM WIRE ASM-CHASSIS
2 PIN HSG
CIRCUIT: DDJ

FROM WIRE ASM-CHASSIS
2 PIN HSG
CIRCUITS: NNZ, PPA

FROM WIRE ASM-SLIDEOUT POWER
4 PIN HSG
CIRCUITS: LLK, LLL, LLM, LLN

FROM WIRE ASM-CHASSIS
10 PIN HSG
CIRCUITS: DU, GGD, GGE, GGF, DR, VVP, DDJ, VVN, VVR-1

FROM WIRE ASM-SLIDEOUT RAMS
6 PIN HSG
CIRCUITS: GGH, GGG, GGJ, GGL, GJK, GGM

FROM WIRE ASM-SLIDEOUT RAMS
5 PIN HSG
CIRCUITS: LLS, LLT, LLW, LLU

6 PIN HSG FROM WIRE ASM-CHASSIS WITH ORANGE TAPE

DETAIL AC

6 PIN HSG FROM FRONT RIGHT ROOM REAR MOTOR

DETAIL AD

COVER-ELECTRICAL
000032697 / 317263-01-CHT
LABEL-SLIDEOUT CTL
098379-09-000
SCREW
G39-08-12U (4)

SLIDEOUT MDOULE, FRONT LEFT
171058-02-000
SCREW
G39-08-08U (4)
DETAIL AD

3 WIRE ASM-MAIN HOLDING TANK
151317-02-000

3 WIRE ASM-AUX HOLDING TANK
151316-03-000

TO COMPT LAMP

3 WIRE ASM-TANK, WATER
151317-01-000

COVER-ELECTRICAL
194965-01-CHT
LABEL-SLIDEOUT CTL
098379-09-000
SCREW
G39-08-12U (4)

CONTROL-SLIDEOUT FRONT RIGHT
189400-01-000
SCREW
G39-08-12U (4)
DETAIL AC

PANEL-RECEPTACLE
151376-01-CHT
SCREW
G67-10-12B (4)
PANEL-RECEPTACLE
151376-02-CHT
LABEL-COAX
157486-01-CHT
ADAPTER
82134-01-000
NUT
82136-01-000
SCREW
G67-10-12B (4)

1DF

299

4 PIN HSG TO WATER HEATER

WIRE ASM-COACH
000032930 / 317351-01-000

MODULE-WATER PUMP
176001-01-000
DETAIL AB

2 PIN HSG TO WATER PUMP

SWITCH-WATER PUMP
108357-21-000
ACTUATOR
108356-03-CHT
(CIRCUITS JA, JY, XXZ, YYF)

PLATE-WALL, DUAL COAX
149557-03-CHT
SCREW
G39-08-08U (2)

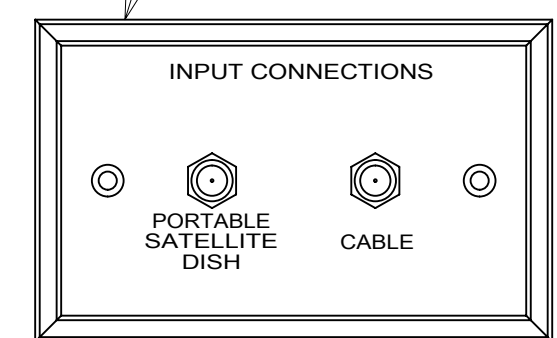

VIEW AA

SWITCH-AUTO LEVEL
108357-18-000
ACTUATOR
108356-03-CHT
(CIRCUITS SSD, SSE, SSC, SSF, SSE)

FOR ELECTRICAL TORQUE SPECIFICATIONS SEE DWG NO. 128783-01-000

FOR ELECTRICAL CALLOUTS SEE DWG NO. 121339-01-000

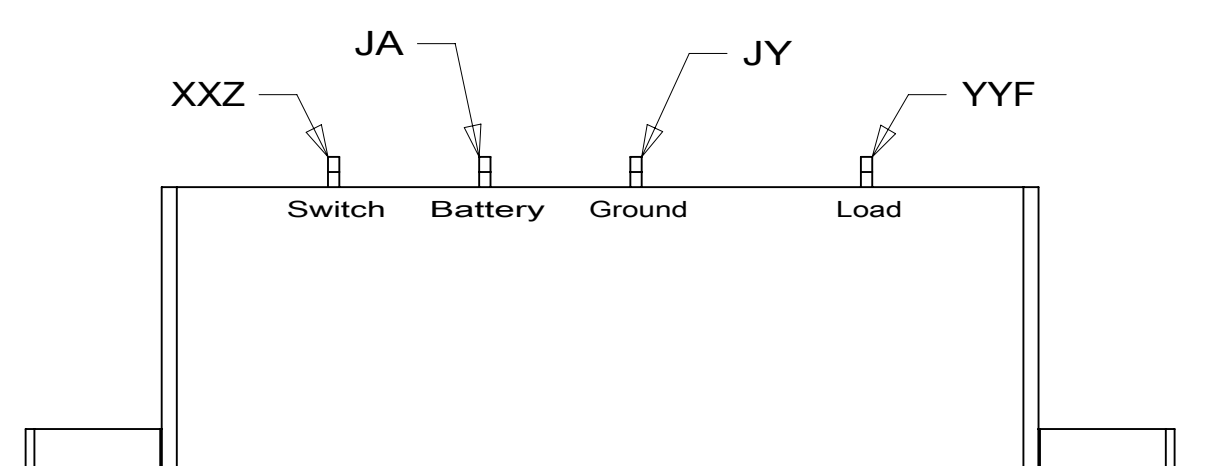

DETAIL AB

- 1DF EXT TV ENTERTAINMENT CENTER
- 299 ENTERTAINMENT CENTER EXT.W/O
- 265 CODES/STANDARDS-CSA/CMVSS
- 1B1 CODES/STANDARDS USA

1B1 265



DSNR:	ALL DIMENSIONS ARE IN MILLIMETERS	
DIFFR:		
UNSPECIFIED TOLERANCES:	MATERIAL:	
WHOLE DIM (X) :	3	
ONE-PLACE (X.X) :	1.5	
TWO-PLACE (X.XX) :	0.50	
ANGLE :	1°	
REFER TO ES0018 FOR FASTENER TIGHTENING GUIDELINES	WEIGHT: (LBS)	FIRST USED:
		17 D35G
DESCRIPTION:		
WIRING INSTL-BODY, 12V		
SHEET:	ITEM/PART NO.:	REV:
1 OF 7	000032542 / 31722901000	

- 4 WIRE PASSES THROUGH FLOOR IN THIS AREA.
- 3 PLACE CROSS LOCATOR ON SENSOR OVER DIMPLES ON TANK.

2. ROUTE TANK SENSOR WIRES SO THEY DO NOT PASS OVER SENSORS. USE WIRE TIE MOUNT 155366-01-000 AND WIRE TIE 8343-01-000 AS NEEDED. TANK SURFACE MUST BE CLEANED USING ISOPROPYL ALCOHOL AND PRIMED WITH PRIMER 94.

1. AT MINIMUM ALL WIRES TO BE SUPPORTED AND SECURED PER CODE REQUIREMENTS. USE CLAMP 10495 OR 10497 OR WIRE TIE 8343 OR 108046 AND SCREW G67-XX-XXX OR G56-XX-XXX AS APPROPRIATE FOR INSTALLATION.

NOTES:

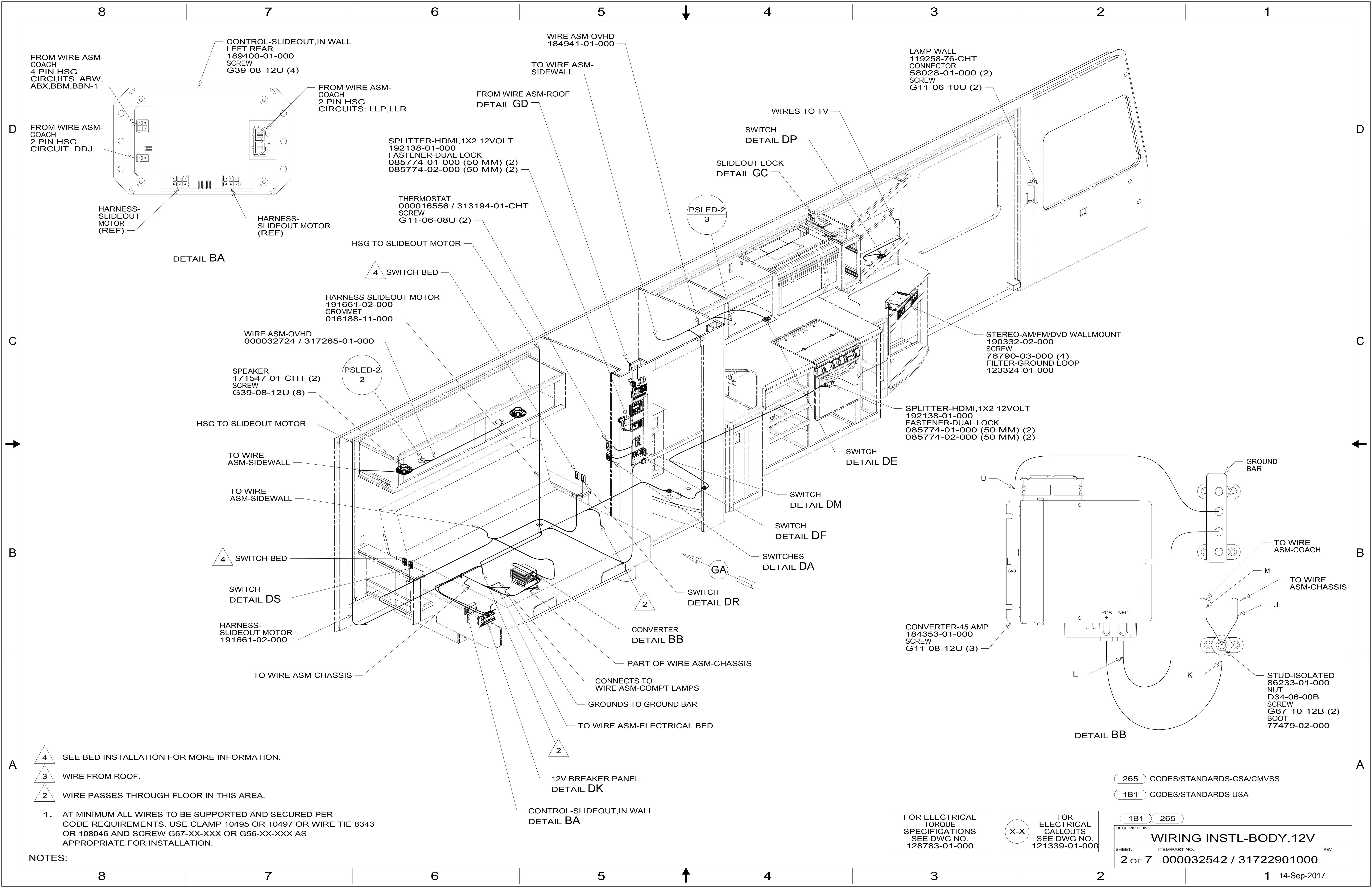

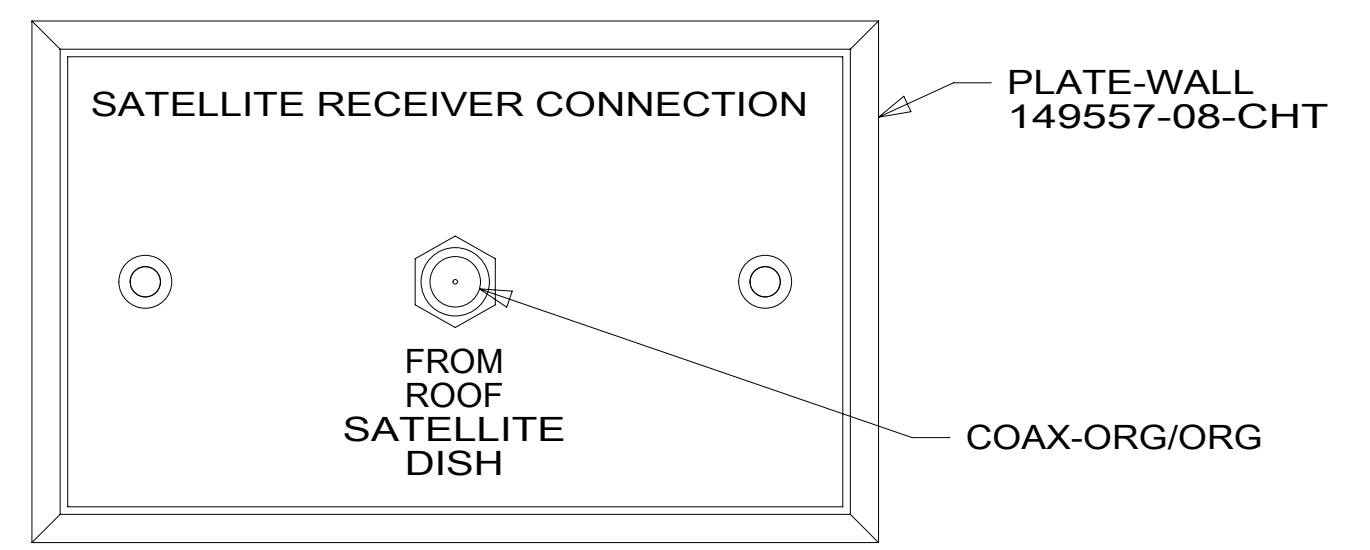
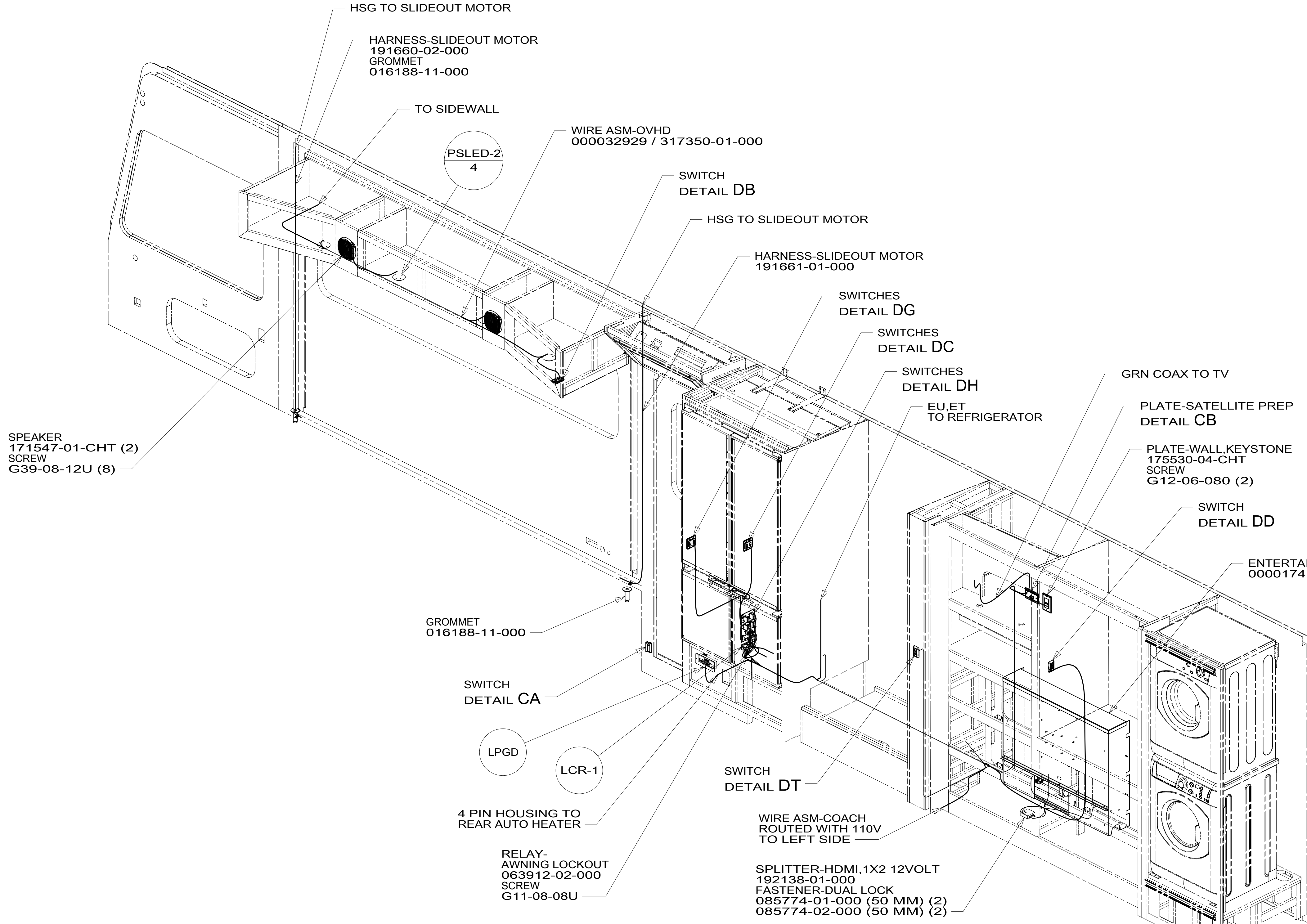
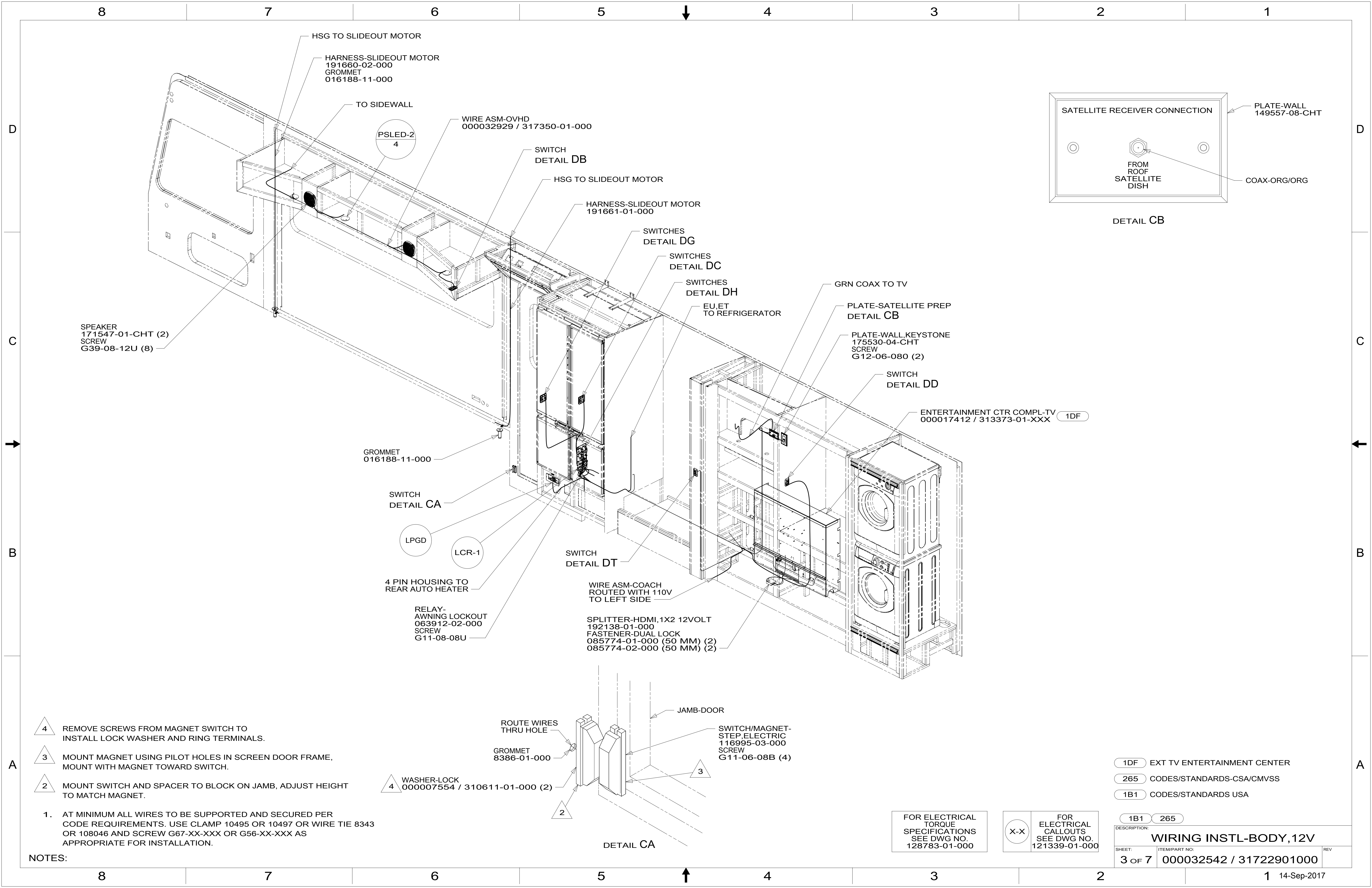

DETAIL CB

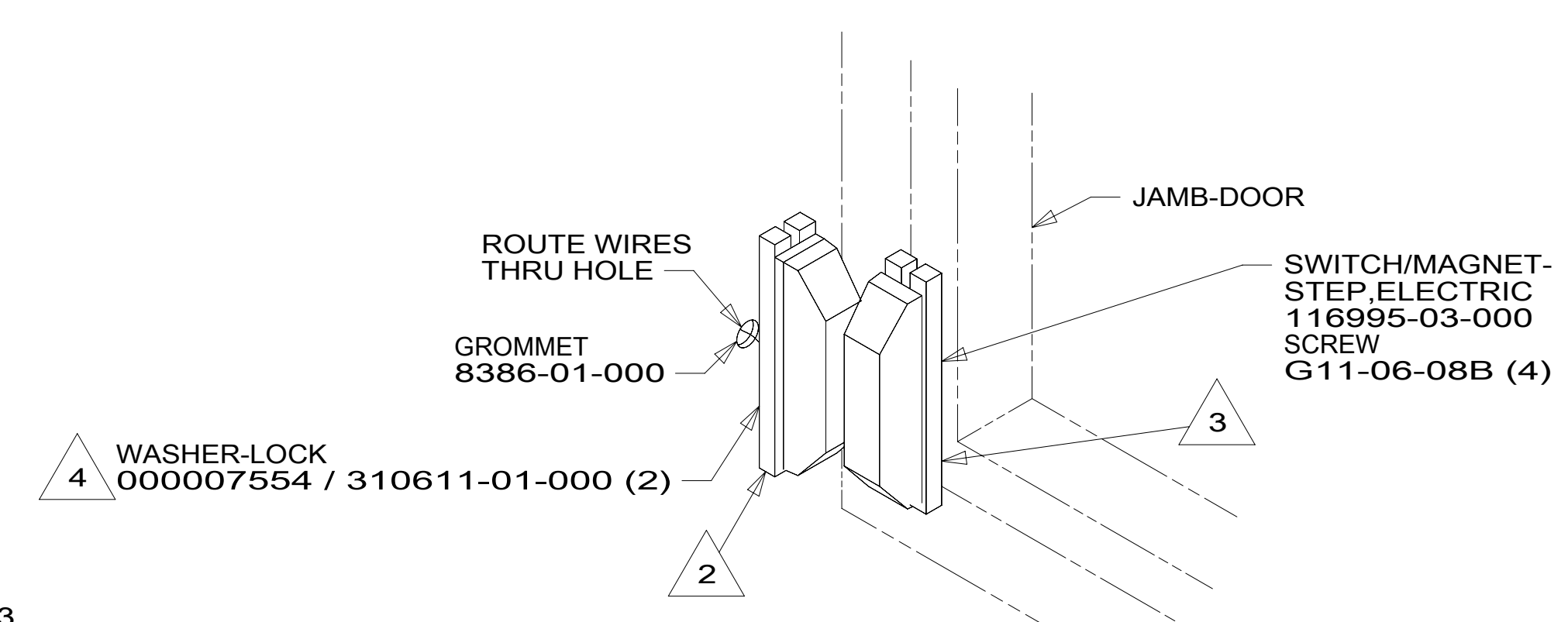

DETAIL CA

- 4 REMOVE SCREWS FROM MAGNET SWITCH TO INSTALL LOCK WASHER AND RING TERMINALS.
- 3 MOUNT MAGNET USING PILOT HOLES IN SCREEN DOOR FRAME, MOUNT WITH MAGNET TOWARD SWITCH.
- 2 MOUNT SWITCH AND SPACER TO BLOCK ON JAMB, ADJUST HEIGHT TO MATCH MAGNET.
1. AT MINIMUM ALL WIRES TO BE SUPPORTED AND SECURED PER CODE REQUIREMENTS. USE CLAMP 10495 OR 10497 OR WIRE TIE 8343 OR 108046 AND SCREW G67-XX-XXX OR G56-XX-XXX AS APPROPRIATE FOR INSTALLATION.

NOTES:

- 1DF EXT TV ENTERTAINMENT CENTER
- 265 CODES/STANDARDS-CSA/CMVSS
- 1B1 CODES/STANDARDS USA

FOR ELECTRICAL TORQUE SPECIFICATIONS SEE DWG NO. 128783-01-000

FOR ELECTRICAL CALLOUTS SEE DWG NO. 121339-01-000

DESCRIPTION:		1B1 265	
WIRING INSTL-BODY, 12V			
SHEET:	ITEM/PART NO.:	REV:	
3 OF 7	000032542 / 31722901000		

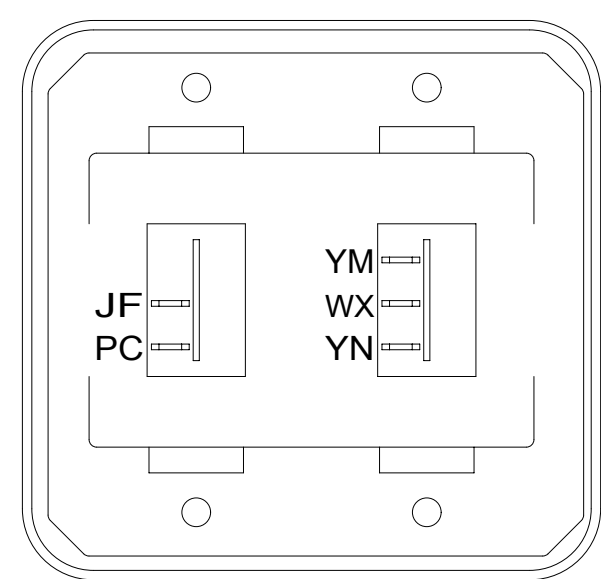

SWITCH-ROCKER
135740-01-CHT
135740-02-CHT
SWITCH-BASE
135741-02-CHT
SWITCH-BEZEL
135742-02-CHT
SCREW
G11-08-08U (4)

DETAIL DA

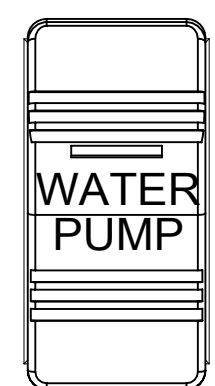

DETAIL DF

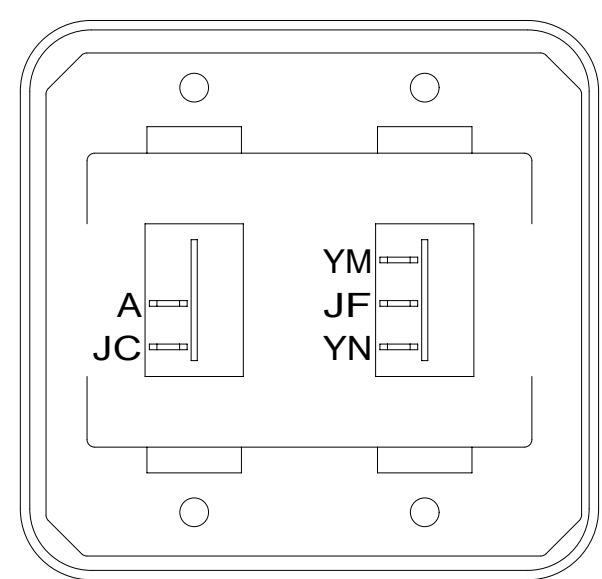

SWITCH-ROCKER
135740-01-CHT
135740-02-CHT
SWITCH-BASE
135741-02-CHT
SWITCH-BEZEL
135742-02-CHT
SCREW
G11-08-08U (4)

DETAIL DG

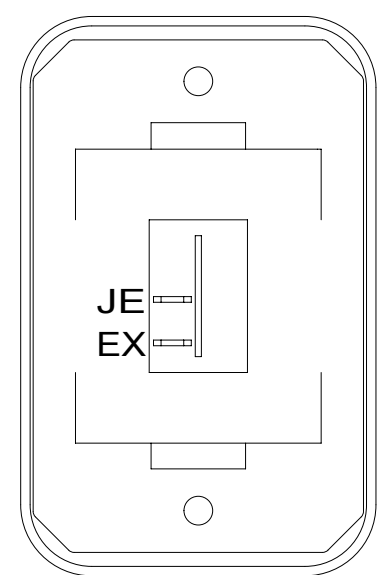

SWITCH-ROCKER
135740-01-CHT
SWITCH-BASE
135741-01-CHT
SWITCH-BEZEL
135742-01-CHT
SCREW
G11-08-08U (2)

DETAIL DB

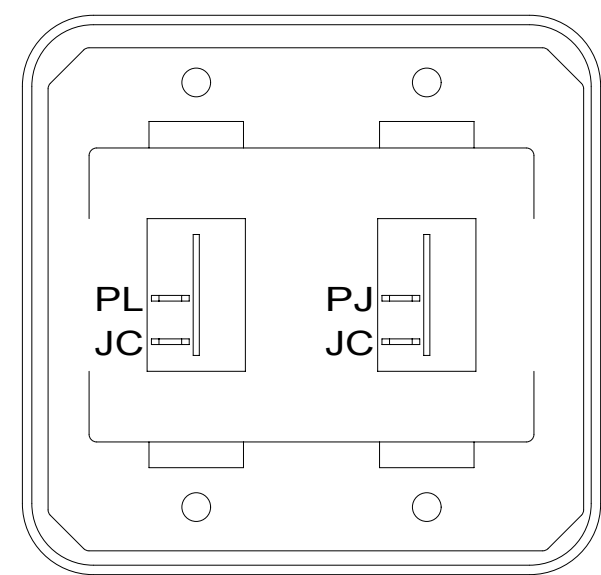

SWITCH-ROCKER
135740-01-CHT (2)
SWITCH-BASE
135741-02-CHT
SWITCH-BEZEL
135742-02-CHT
SCREW
G11-08-08U (4)

DETAIL DC

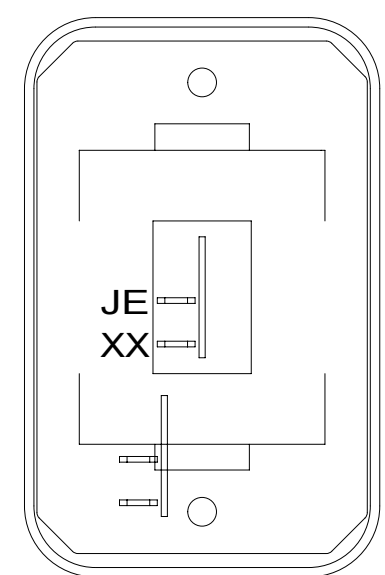

SWITCH-ROCKER
135740-01-CHT
SWITCH-BASE
135741-01-CHT
SWITCH-BEZEL
135742-01-CHT
SCREW
G11-08-08U (2)

DETAIL DD

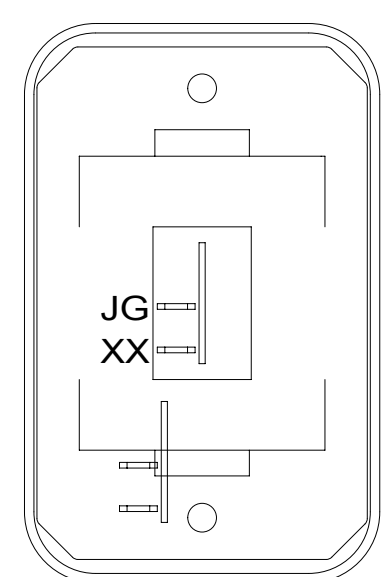

SWITCH-ROCKER
135740-01-CHT
SWITCH-BASE
135741-01-CHT
SWITCH-BEZEL
135742-01-CHT
SCREW
G11-08-08U (2)

DETAIL DE

SWITCH-AWNING
108357-06-000
ACTUATOR-SWITCH
108356-12-CHT
CIRCUITS
FFD,FFR,FFE,
FFE,JJR,FFD

SWITCH-COMT LIGHTS
108357-01-000
ACTUATOR-SWITCH
108356-14-CHT
CIRCUITS WC,NW

SWITCH-COACH BATT
108357-18-000
ACTUATOR-SWITCH
108356-19-CHT
CIRCUITS KF,
LJ-1,LG,LH,WC
WIRE ASM-THERM
186796-01-000

PLATE-SWITCH
158431-23-CHT
SCREW
G11-06-10U (6)

SWITCH-AWNING LIGHTS
108357-14-000
ACTUATOR-SWITCH
108356-28-CHT
CIRCUITS RS,
ZZK,WE,ZZK

SWITCH-AUTO LEVEL
108357-18-000
ACTUATOR-SWITCH
108356-15-CHT
CIRCUITS SSD,SSE,
SSC,SSE,SSF

SWITCH-STEP
108357-19-000
CIRCUITS ER,ES

SWITCH-CHASSIS BATTERY
108357-18-000
ACTUATOR-SWITCH
108356-20-CHT
CIRCUITS TTY,TTZ,MK,
UUB-1,UUC
WIRE ASM-THERM
186796-01-000

SWITCH-CONTROL,
LOFTBED,TOUCH
189056-01-000
WIRE ASM-LOFT
BED SWITCH
000122806 / 323456-01-000
SCREW
000G11-02-08U (2)

SWITCH
108357-06-000
ACTUATOR
108356-25-CHT

LABEL-SLIDEOUT,
PASS,FRONT
163992-04-CHT

LABEL-SLIDEOUT,
DRIVER,FRONT
163992-01-CHT

SLIDEOUT-ELEC.FRONT
171341-01-000
SCREW
76790-05-000 (2)

CONNECT TO 12-PIN
HOUSING WITH CIRCUITS
SSP,GGE,GGF,
GGD,DR,DU,VVP,VVN

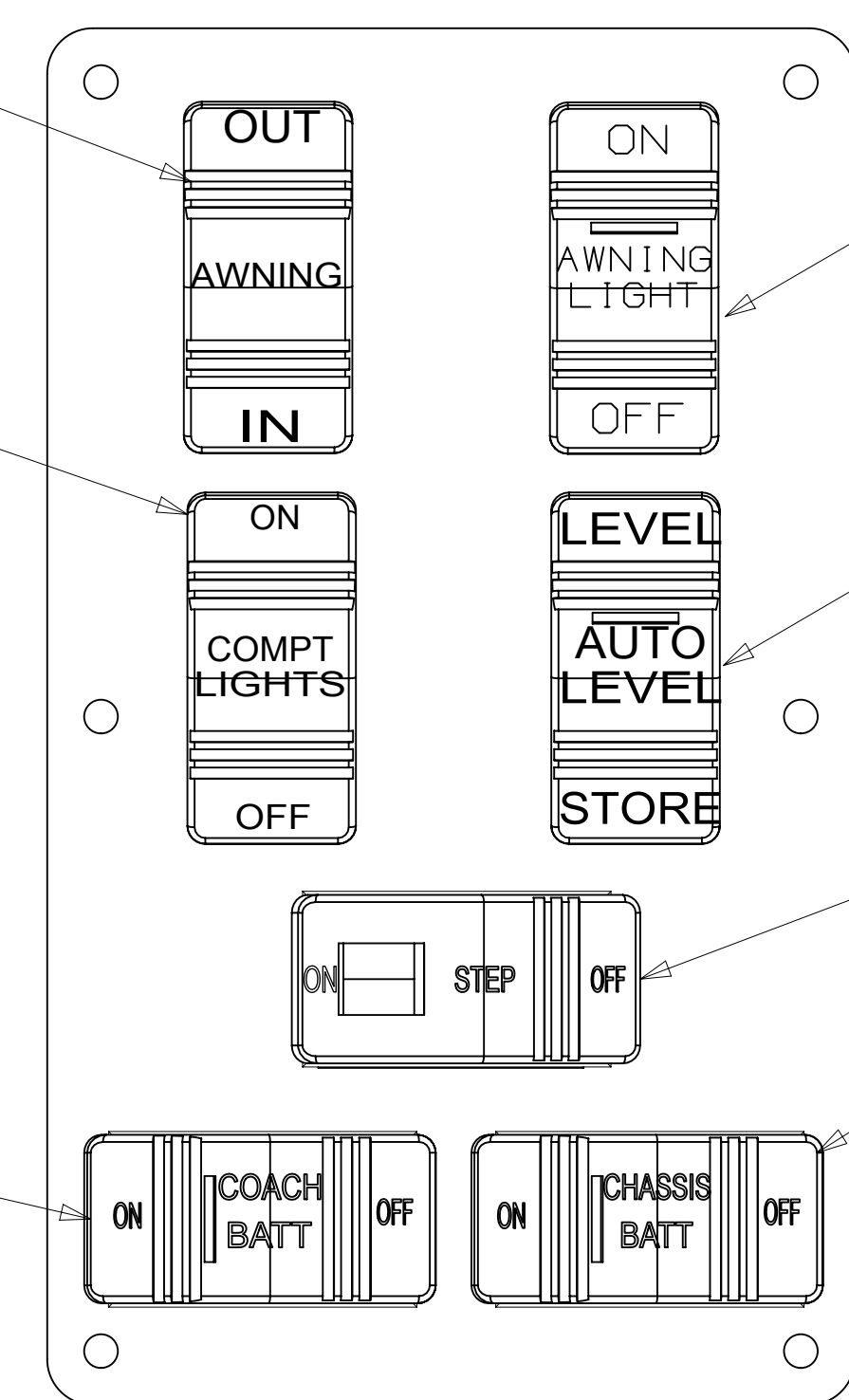

DETAIL DH

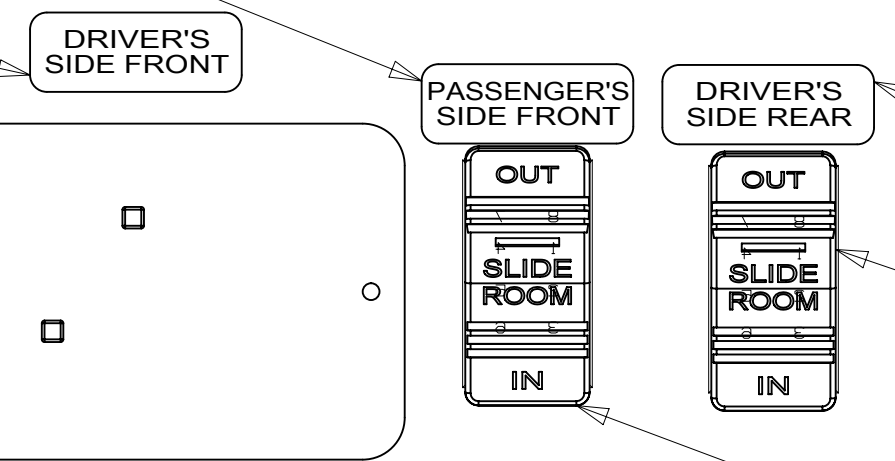
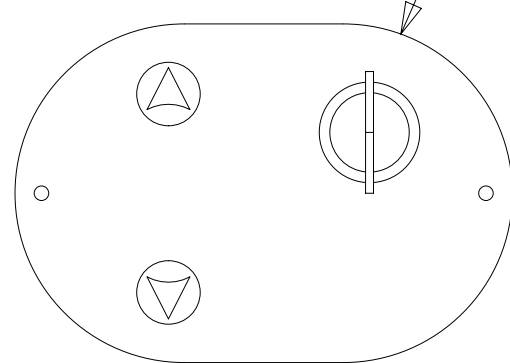

DETAIL DN

LABEL-WARNING,SLIDEOUT
116549-01-000

WARNING CRUSH HAZARD. Keep people and objects clear of the inside and the outside of the slideout room when operating. Failure to comply could result in death or serious injury.

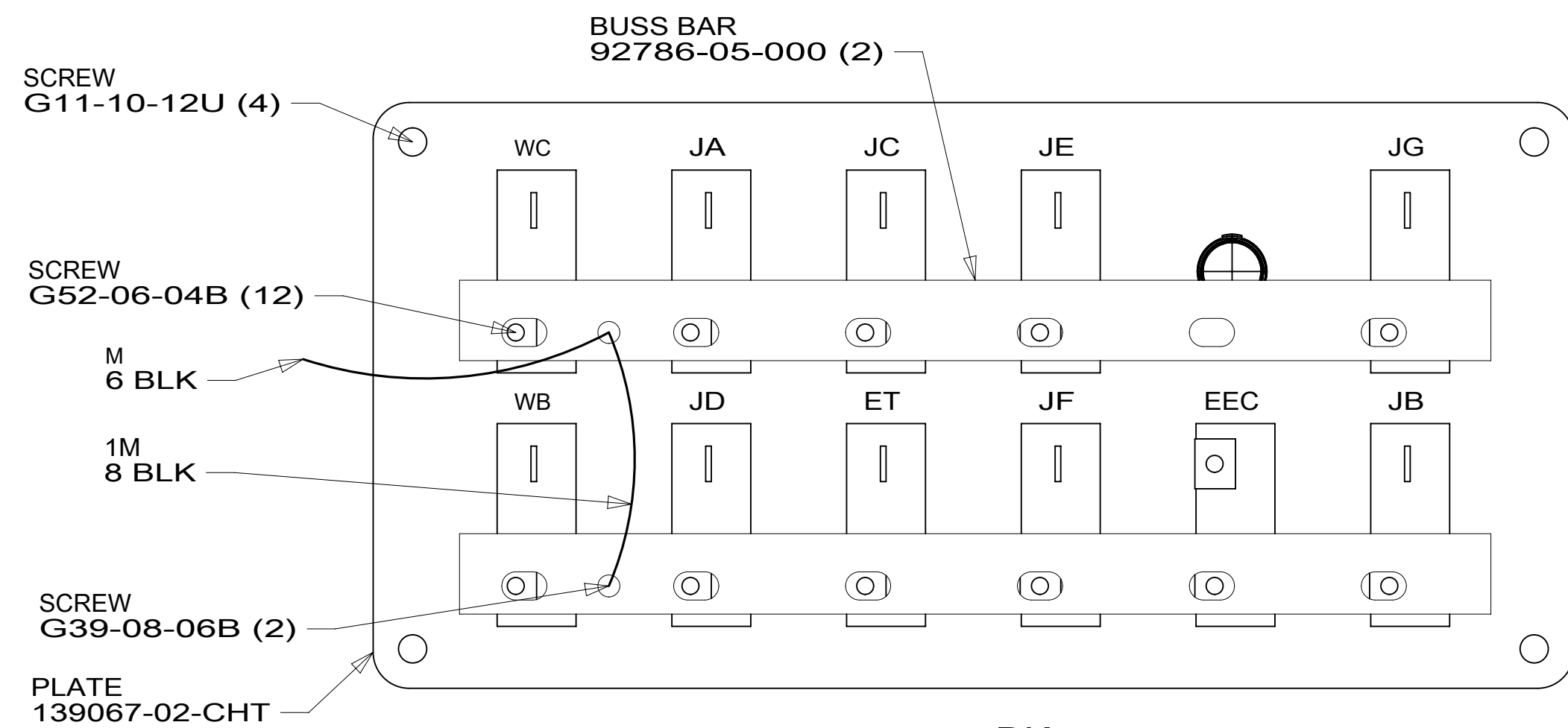

DETAIL DK
(BACK VIEW)

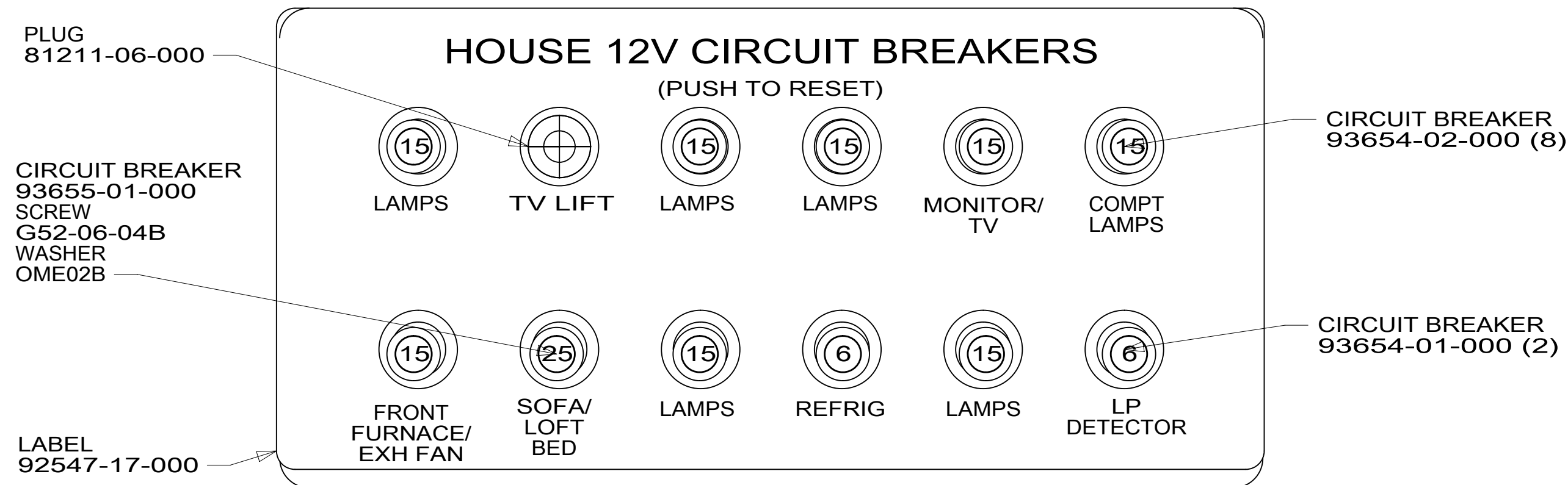

DETAIL DK
(FRONT VIEW)

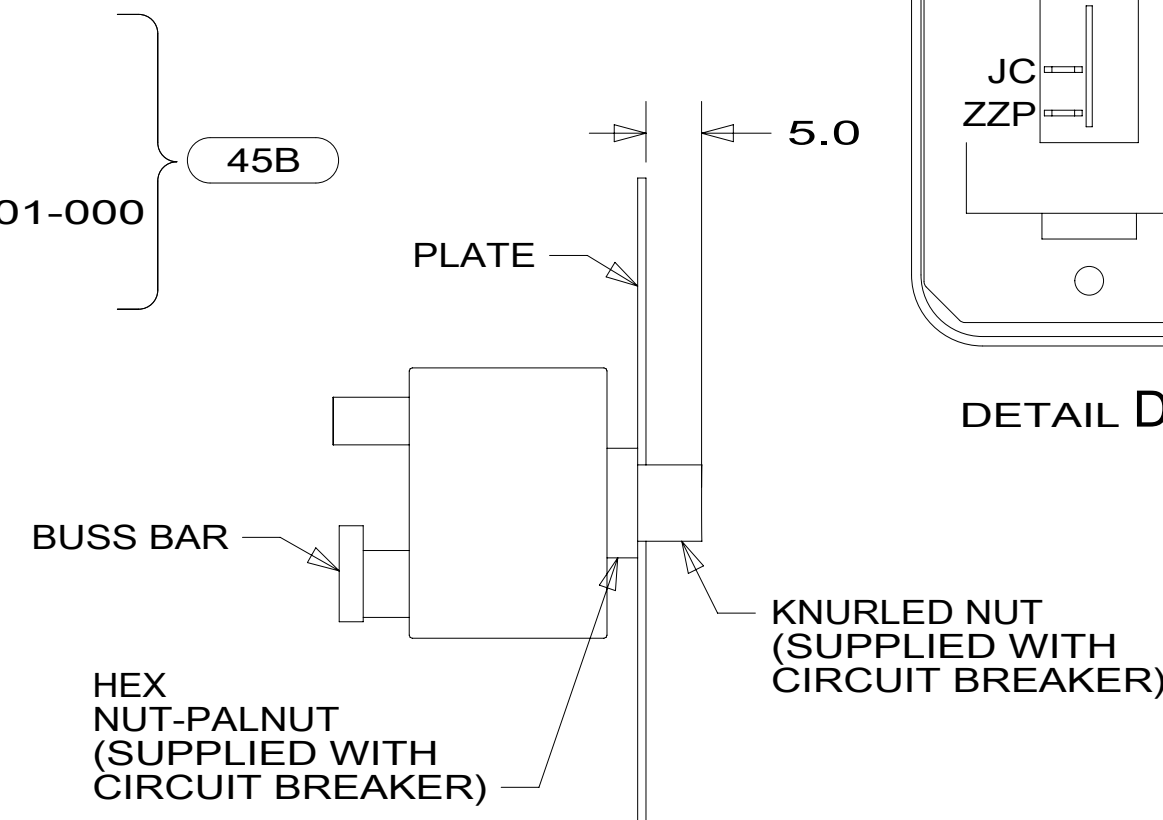

DETAIL DL-DL

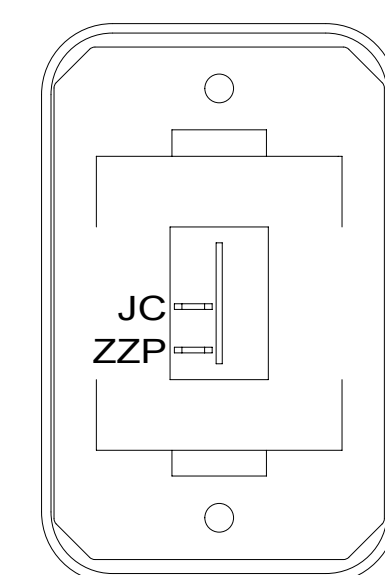

DETAIL DR

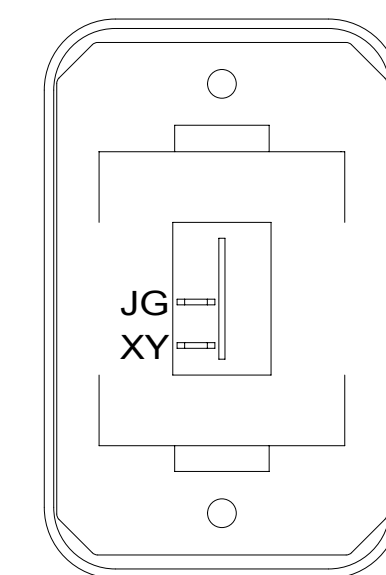

DETAIL DP

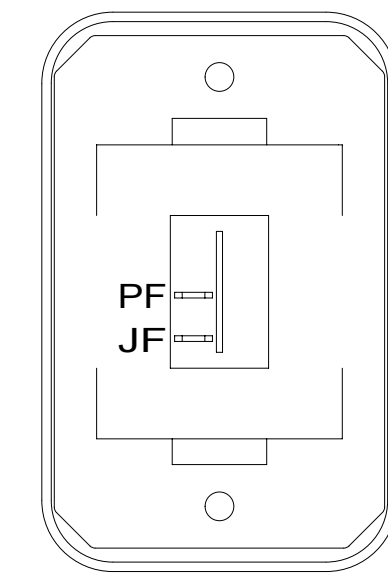

DETAIL DT

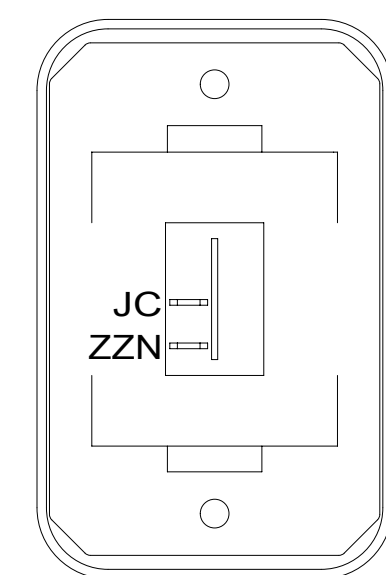

DETAIL DS

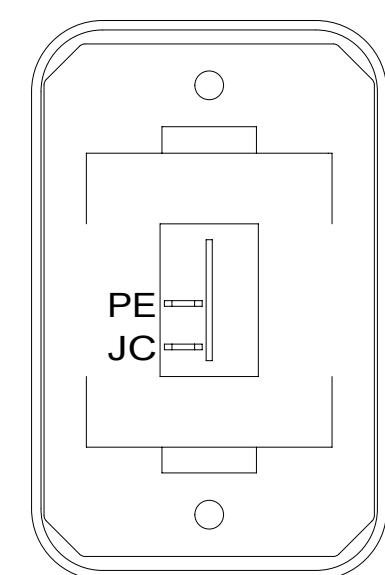

DETAIL DM

SWITCH-ROCKER
135740-01-CHT
SWITCH-BASE
135741-01-CHT
SWITCH-BEZEL
135742-01-CHT
SCREW
G11-08-08U (2)

SWITCH-ROCKER
135740-01-CHT
SWITCH-BASE
135741-01-CHT
SWITCH-BEZEL
135742-01-CHT
SCREW
G11-08-08U (2)

SWITCH-ROCKER
135740-01-CHT
SWITCH-BASE
135741-01-CHT
SWITCH-BEZEL
135742-01-CHT
SCREW
G11-08-08U (2)

SWITCH-ROCKER
135740-01-CHT
SWITCH-BASE
135741-01-CHT
SWITCH-BEZEL
135742-01-CHT
SCREW
G11-08-08U (2)

NOTES:
1 FOR SWITCH ORIENTATION SEE DETAIL DJ.

FOR ELECTRICAL
TORQUE
SPECIFICATIONS
SEE DWG NO.
128783-01-000

FOR ELECTRICAL
CALLOUTS
SEE DWG NO.
121339-01-000

45B LOFT BED
265 CODES/STANDARDS-CSA/CMVSS
1B1 CODES/STANDARDS USA

DESCRIPTION:
WIRING INSTL-BODY, 12V
SHEET: 4 OF 7
ITEM/PART NO.: 000032542 / 31722901000
REV

8 7 6 5 4 3 2 1

D
C
B
A

D
C
B
A

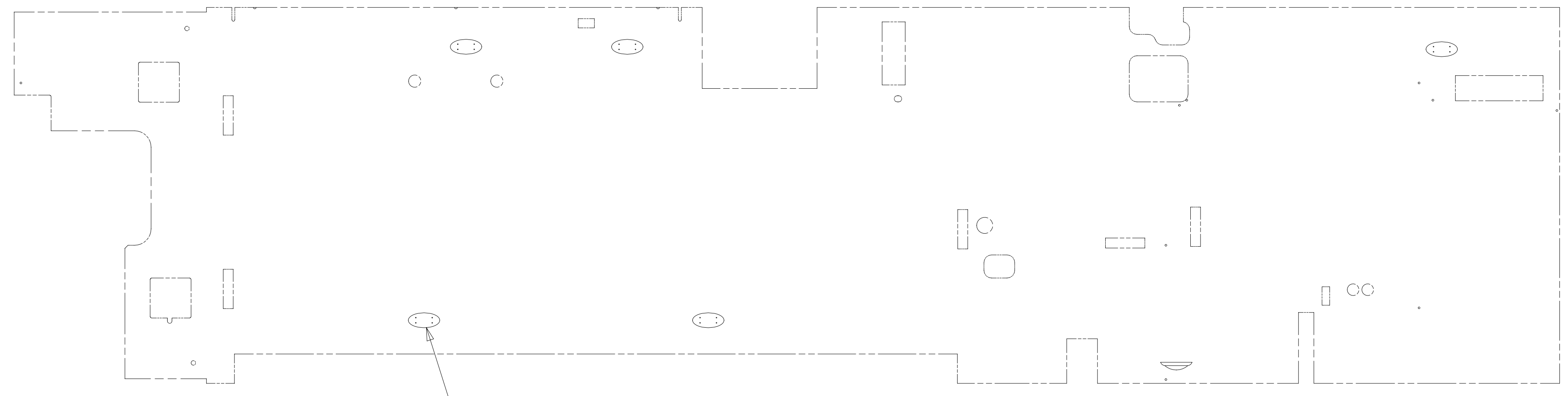
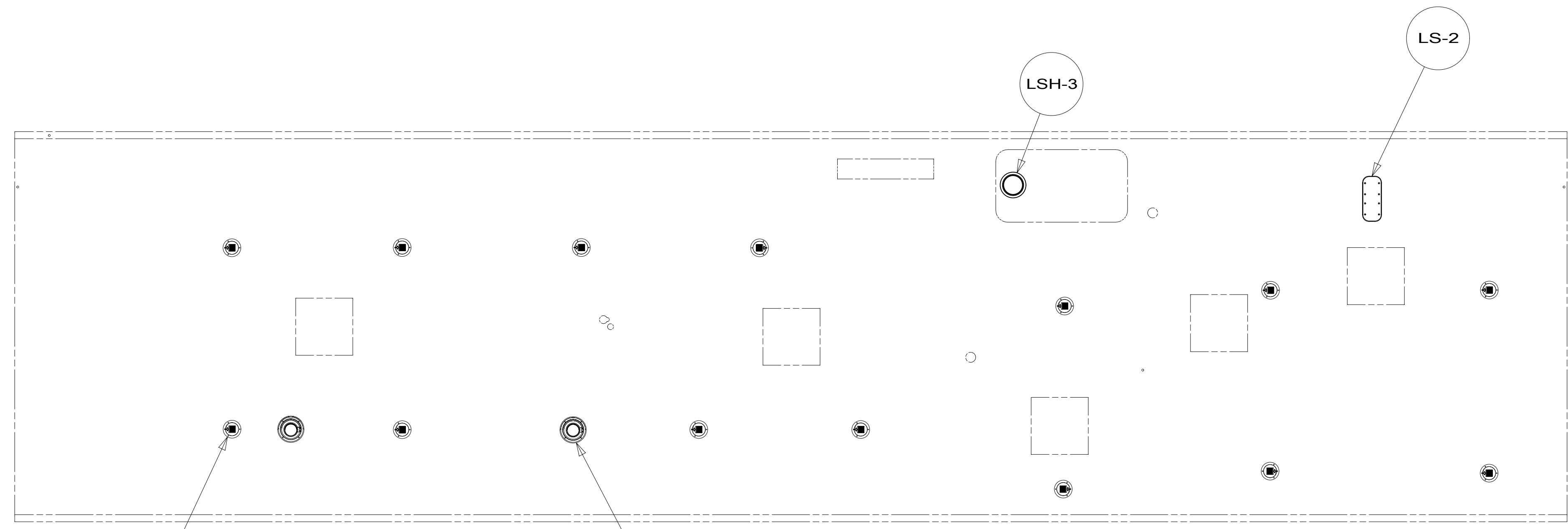

8 7 6 5 4 3 2 1 14-Sep-2017

265 CODES/STANDARDS-CSA/CMVSS
 1B1 CODES/STANDARDS USA

FOR ELECTRICAL TORQUE SPECIFICATIONS SEE DWG NO. 128783-01-000

FOR ELECTRICAL CALLOUTS SEE DWG NO. 121339-01-000

DESCRIPTION:	
1B1 265	
WIRING INSTL-BODY, 12V	
SHEET:	ITEM/PART NO. REV
5 OF 7	000032542 / 31722901000

THE SATELLITE DISH WIRE CONNECTIONS ARE TO BE PLACED IN THE CENTERLINE OF THE MOTORHOME FACING FORWARD

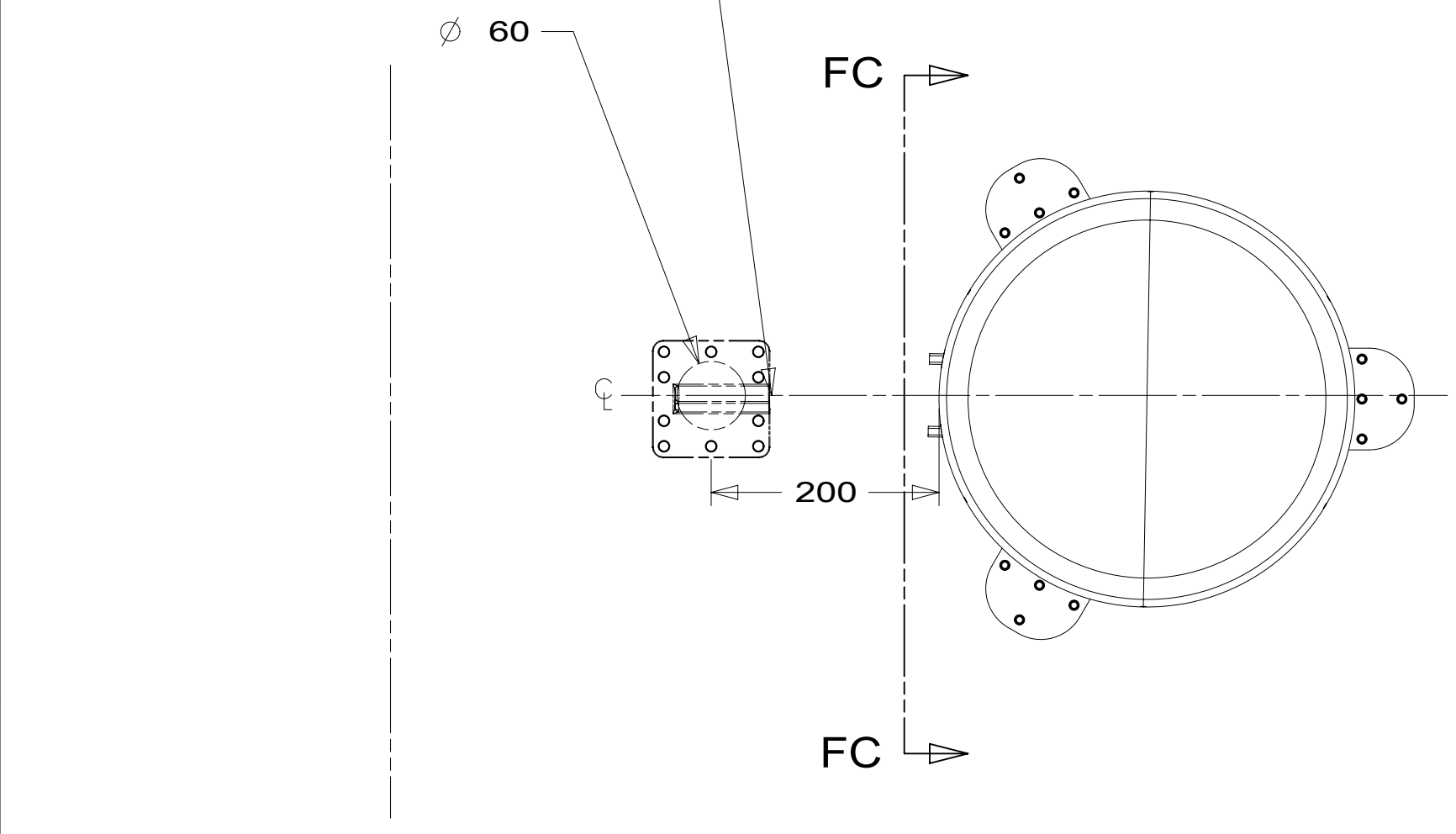

DETAIL FB

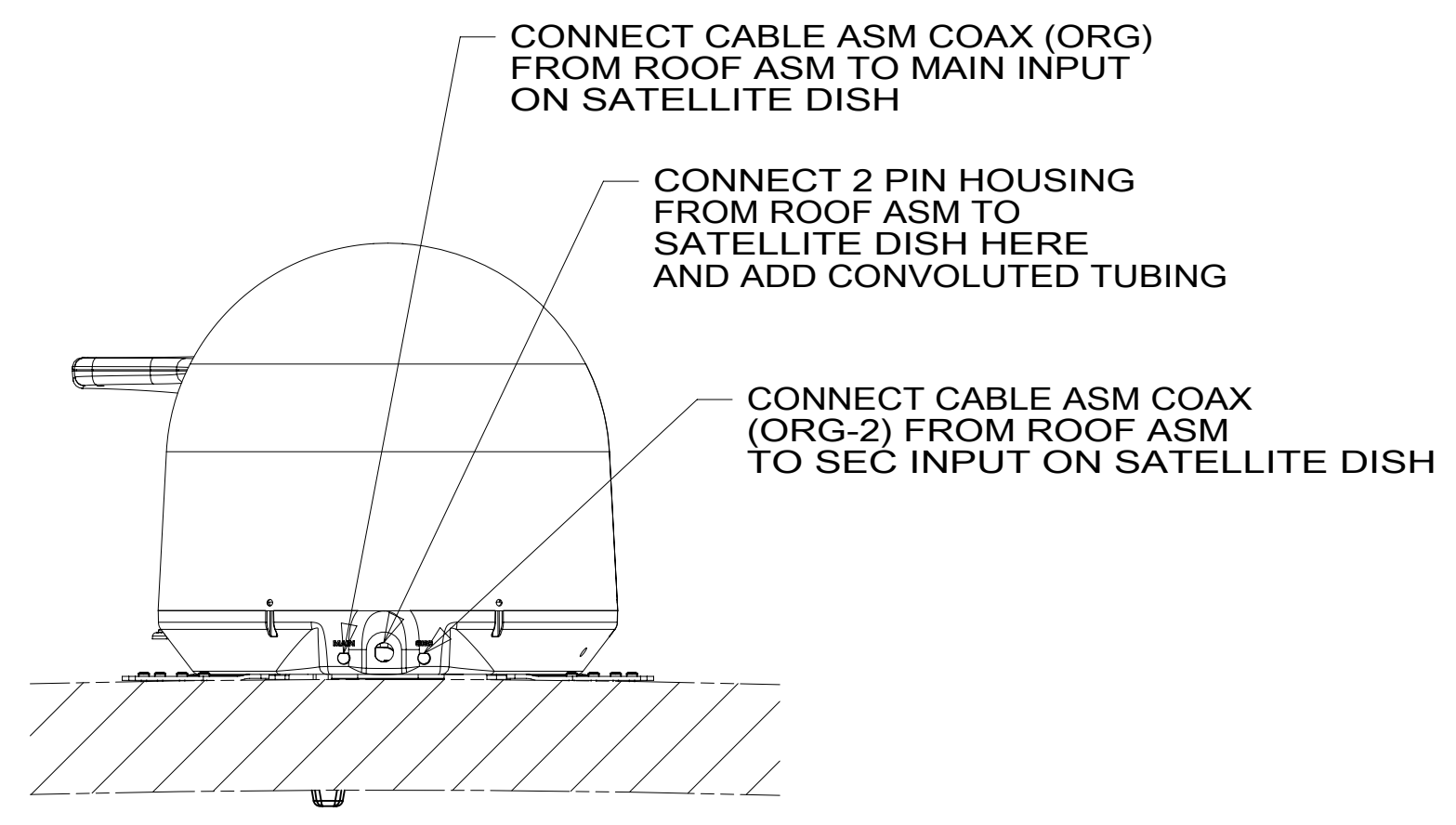

SECTION FC-FC

- ANTENNA-SATELLITE, STATIONARY
- 000017113 / 313336-01-CHT
- SCREW
- 000G39-08-08U (9)
- COAX CABLE
- 163598-04-000 (2)
- ADAPTER
- 082134-01-000 (2)
- CONDUIT
- 041953-06-000 (200 MM)
- SCREW
- 000G67-10-12U (10)
- (FOR PLATE SUPPLIED W/ DISH)
- DETAIL FB

78K

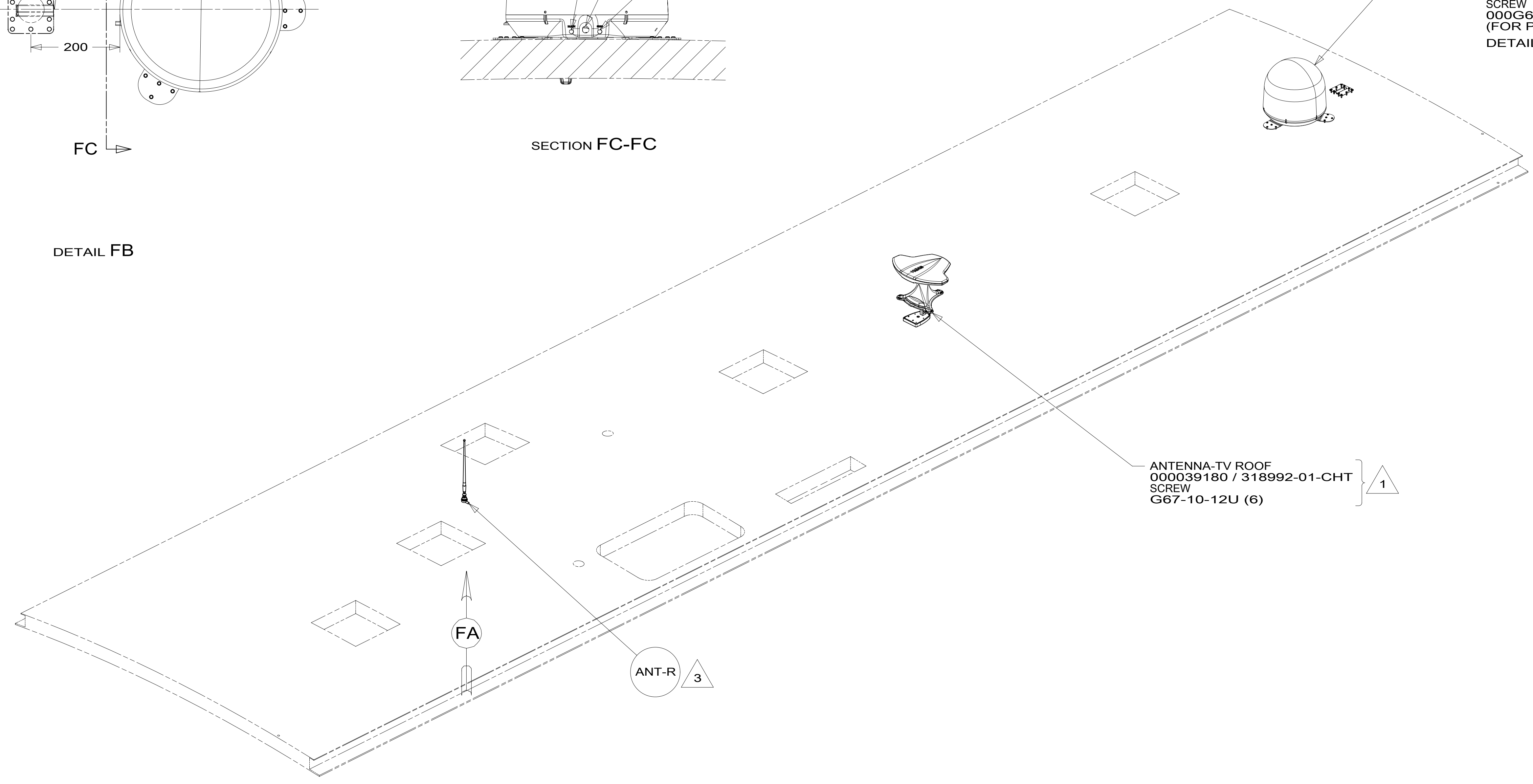

- ANTENNA-TV ROOF
- 000039180 / 318992-01-CHT
- SCREW
- G67-10-12U (6)

1

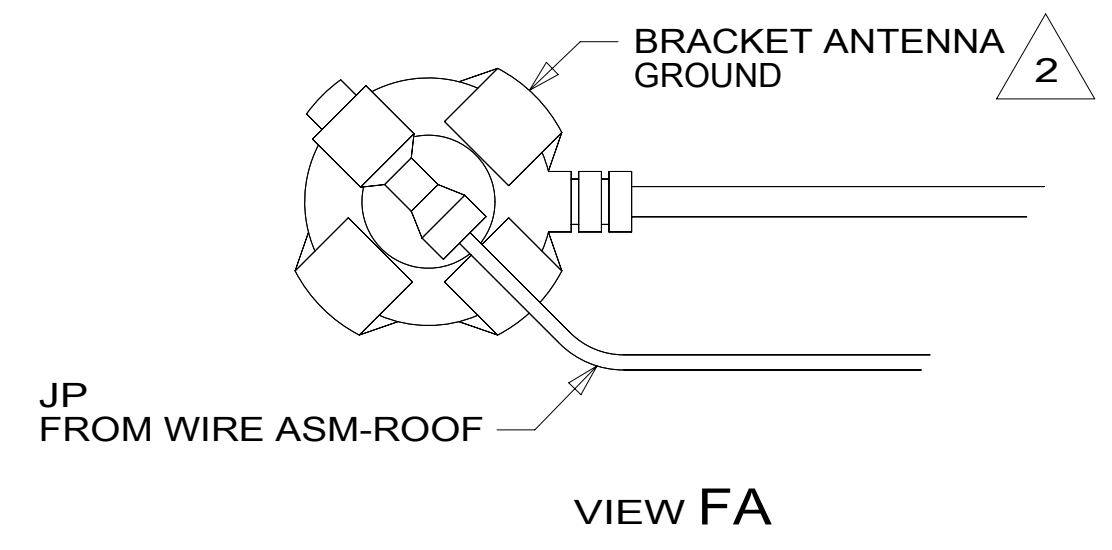

VIEW FA

- NOTES:
- 3 REMOVE GROUND WIRE FROM ANTENNA BASE.
 - 2 WRAP LEGS AROUND ANTENNA BASE.
 - 1 SEE ANTENNA INSTALLATION MANUAL FOR CORRECT INSTALLATION PROCEDURE.

- 78K SATELLITE TV SYSTEM AUTO
- 265 CODES/STANDARDS-CSA/CMVSS
- 1B1 CODES/STANDARDS USA

FOR ELECTRICAL TORQUE SPECIFICATIONS SEE DWG NO. 128783-01-000

FOR ELECTRICAL CALLOUTS SEE DWG NO. 121339-01-000

DESCRIPTION:		1B1 265	
WIRING INSTL-BODY, 12V			
SHEET:	ITEM/PART NO.:	REV	
6 OF 7	000032542 / 31722901000		

