

REV	ZONE	REVISION RECORD	DATE	DFTR-ORIG
A	---	INITIAL RELEASE	08/24/16	3650-6437
B	SHT2	446 LOC DIM WAS 466	09/06/16	3650-6437
C	ALL	FITTINGS CHANGE, VARIOUS LENGTH CHANGE-SEE MARKUP	09/19/16	3650
D	---	TANK CHGS SHT4	10-14-16	1600-6437
E	S1S2	ADD DETAIL BG TO S2B4 AND NOTE 11	11/07/16	9080-2747
F	SHT3	ADDED NEW WATER FILTER AND SECTION TO LOCATE	12/21/16	3650

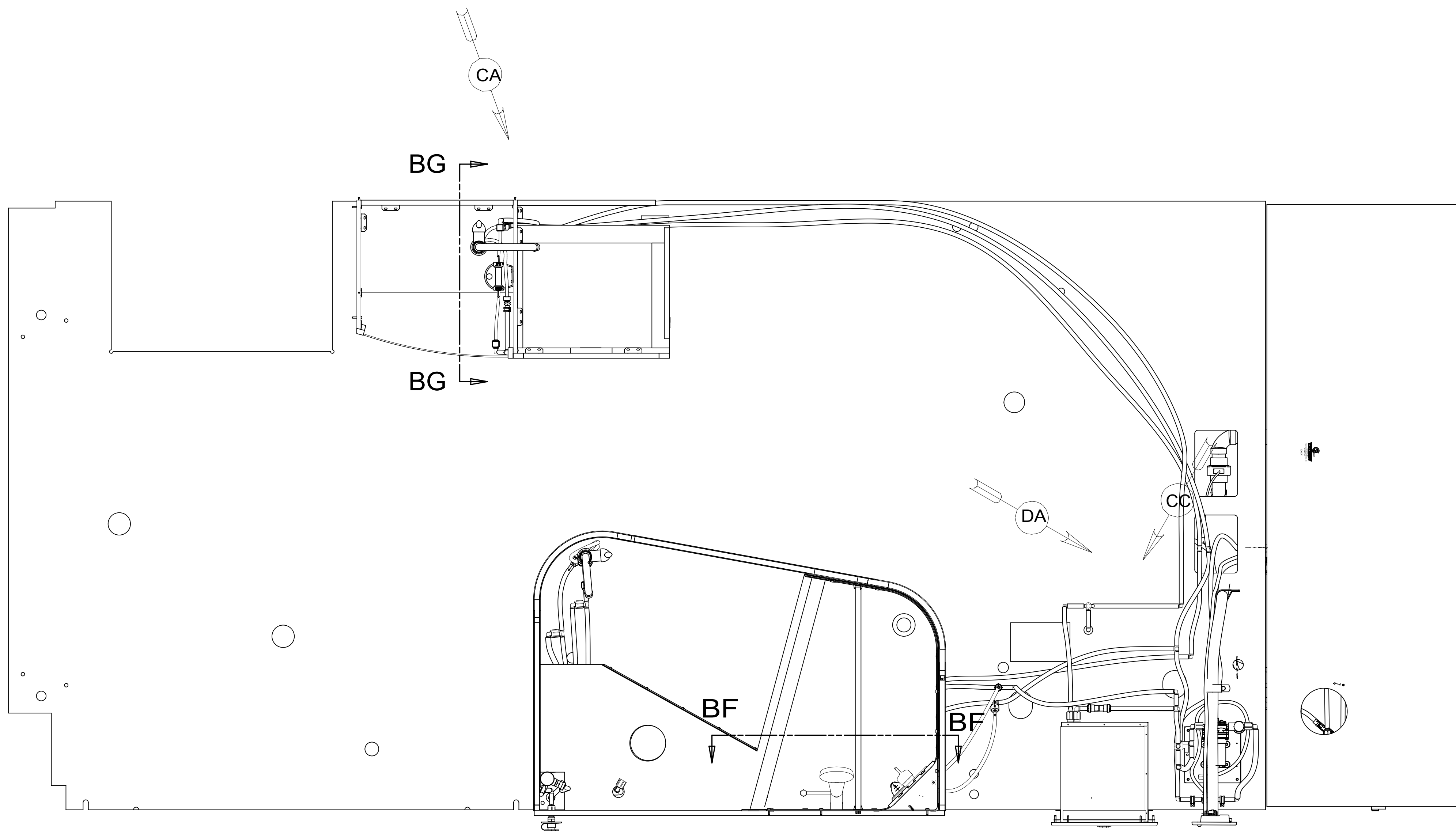

- NOTES:
11. REMOVE WATER HEATER DOOR STRAPS AND HARDWARE.
 10. INSTALL BETWEEN MOUNTING PLATE AND RETAINING NUTS.
 9. INSTALL CONNECTOR WITH TAPERED END AWAY FROM FAUCET.
 8. ALL CRIMP FITTINGS TO 1/2" PEX TUBING REQUIRE 1/2" CLAMP 140171-03-000.
 7. ALL CRIMP FITTINGS TO 5/8" PEX TUBING REQUIRE 5/8" CLAMP 140171-04-000.
 6. LABEL HOT AND COLD SUPPLY TUBES AND TAPE FITTING TO TUBE BEFORE CABINET SET TO PREVENT MOVEMENT.
 5. ADD PIPE WRAP (LADDER SCRAP 110157-02-000) INSULATION.
 4. ADD TEFLON TAPE 010405-02-000.
 3. ALL TUBING TO BE SECURED AT 1200 INTERVALS MAXIMUM WITH CLAMP 010495-01-000 AND SCREW 000G67-10-12U OR EQUIVALENT.
 2. TUBING TO BE INSTALLED WITH SUFFICIENT SLOPE TO PROVIDE DRAINAGE TO NEAREST VALVE.
 1. PLASTIC FITTINGS TO BE SEALED WITH SEALANT 084456-01-000.

FOR WATER CALLOUTS SEE DWG NO. 000209446 / 303369-01-000

WINNEBAGO
COPYRIGHT 2017 WINNEBAGO INDUSTRIES, INC.

DSNR:	ALL DIMENSIONS ARE IN MILLIMETERS	
DFTR:	MATERIAL:	
UNSPECIFIED TOLERANCES:	WHOLE DIM (X) :	3
	ONE-PLACE (X.X) :	1.5
	TWO-PLACE (X.XX) :	0.50
	ANGLE :	1°
REFER TO ES0018 FOR FASTENER TIGHTENING GUIDELINES	WEIGHT: (LBS)	FIRST USED: (REF)
		17 H25T
DESCRIPTION: WATER SYSTEM INSTL		
SHEET: 1 OF 4	ITEM/PART NO: 000030424 / 31670101000	REV:
REF: 1		23-Feb-2017

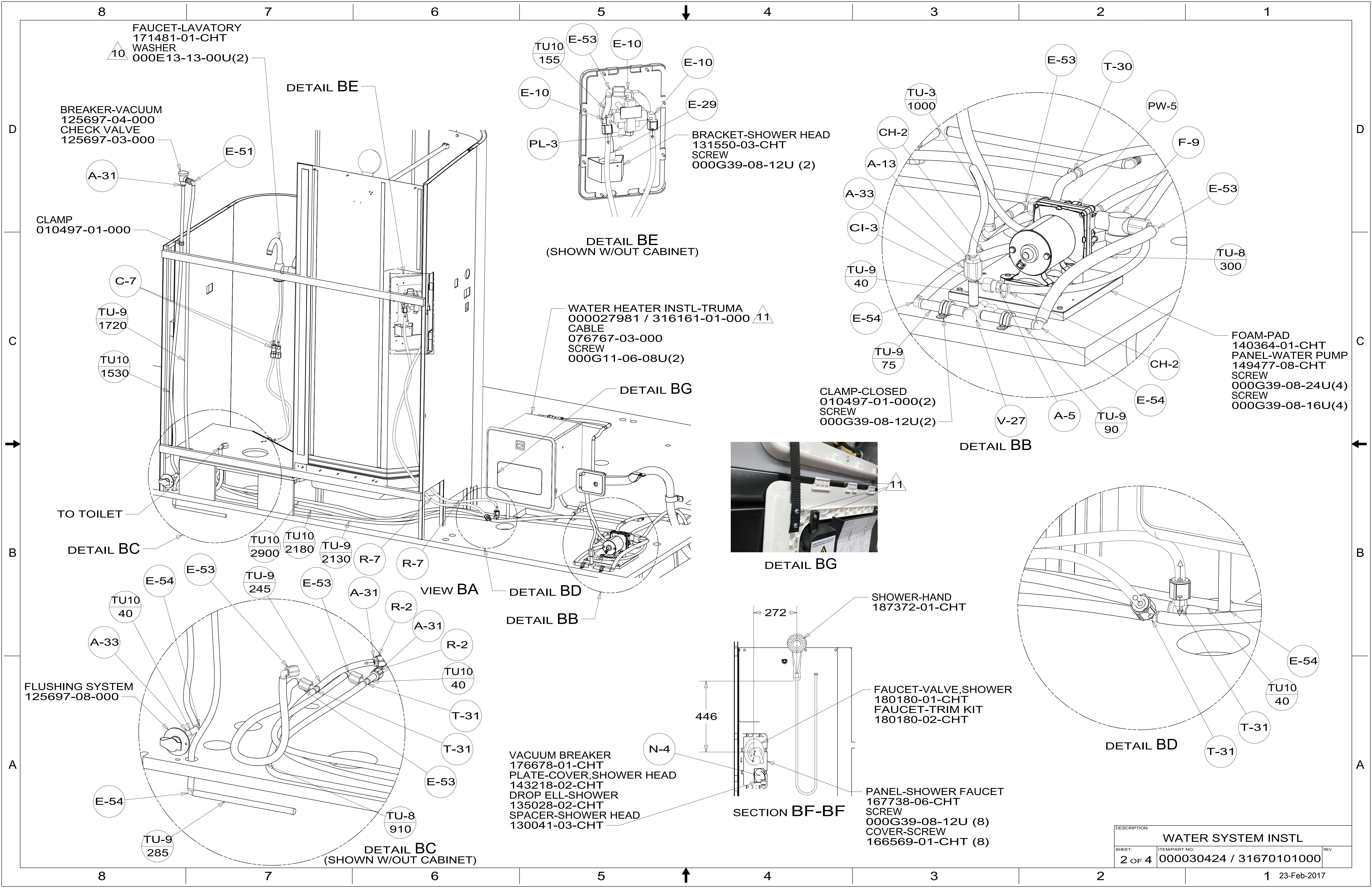

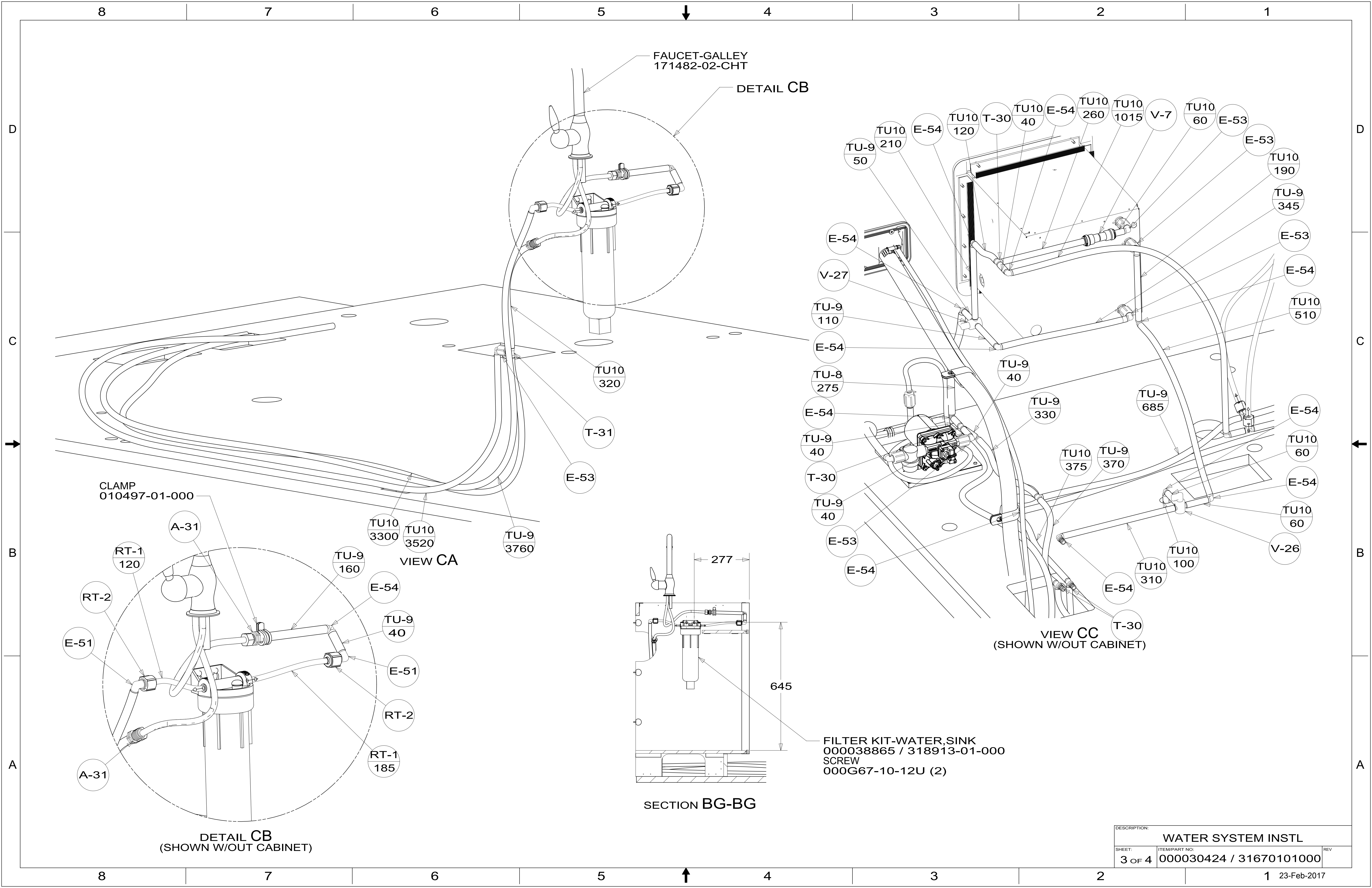

DESCRIPTION:		
WATER SYSTEM INSTL		
SHEET:	ITEM/PART NO:	REV
3 OF 4	000030424 / 31670101000	

