

- 7 WIRE TO BE MARKED BY WRAP OF RED TAPE 19MM WIDE WITHIN 50MM OF END.
- 6 WIRE TO BE MARKED BY WRAP OF PURPLE TAPE 19MM WIDE WITHIN 50MM OF END.
- 5 WIRE TO BE MARKED BY WRAP OF YELLOW TAPE 19MM WIDE WITHIN 50MM OF END.

4. ALL WIRES W/O TERMINALS TO BE STRIPPED 10MM UNLESS OTHERWISE SPECIFIED.

3. DIMENSIONS SHOWN SHALL BE CONSIDERED AS BETWEEN CENTERS OF JUNCTIONS OR BRANCHES. DIMENSIONS SHOWN BETWEEN JUNCTIONS AND CONNECTIONS OR TERMINALS ARE TO END OF WIRE.

2. WIRE ASSEMBLY TO BE SECURED BY WRAP OF TAPE 610 MAX APART AND AT EACH JUNCTION OR BRANCH USIING 7957-01-000 TAPE.

- 1 TOLERANCES TO BE AS FOLLOWS UNLESS OTHERWISE SPECIFIED:
 - A. TOLERANCE OF CUT WIRE LENGTHS SHALL BE +13,-0 OR +1%,-0% WHICHEVER IS LARGER.
 - B. TOLERANCE BETWEEN JUNCTIONS OR BRANCHES SHALL BE +13,-0. SHALL NOT BE CUMULATIVE.

8 WIRE TO BE MARKED BY 2 WRAPS OF YEL TAPE 19MM WIDE WITHIN 50MM OF END.

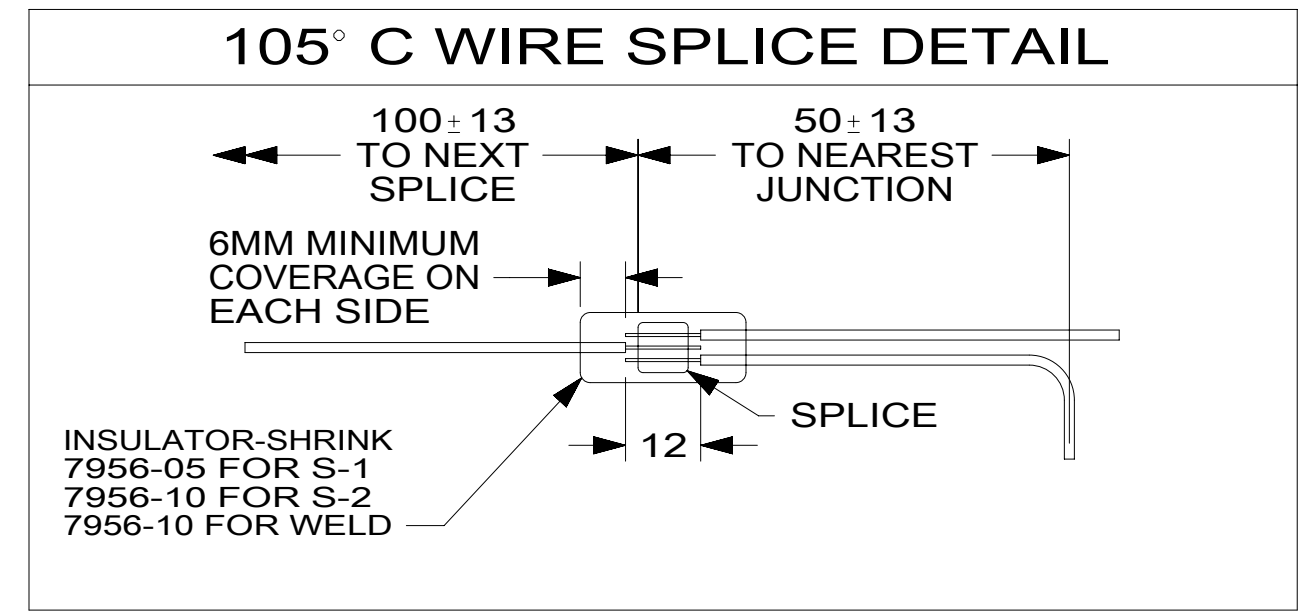

X-X FOR ELECTRICAL CALLOUTS SEE DWG NO. 121339-01-000

WINNEBAGO COPYRIGHT 2016 WINNEBAGO INDUSTRIES, INC.	
DSNR:	ALL DIMENSIONS ARE IN MILLIMETERS
DFFR:	
UNSPECIFIED TOLERANCES:	MATERIAL:
WHOLE DIM (X) :	
ONE-PLACE (X.X) :	
TWO-PLACE (X.XX) :	
ANGLE :	
REFER TO ES0018 FOR FASTENER TIGHTENING GUIDELINES	WEIGHT: (LBS) FIRST USED:
	17 H-SER
WIRE ASM-ELECTRICAL BOX	
SHEET: 1 OF 1	ITEM/PART NO: 000027909 / 31614301000
REV:	REF: 1 27-Apr-2018