

8 7 6 5 4 3 2 1

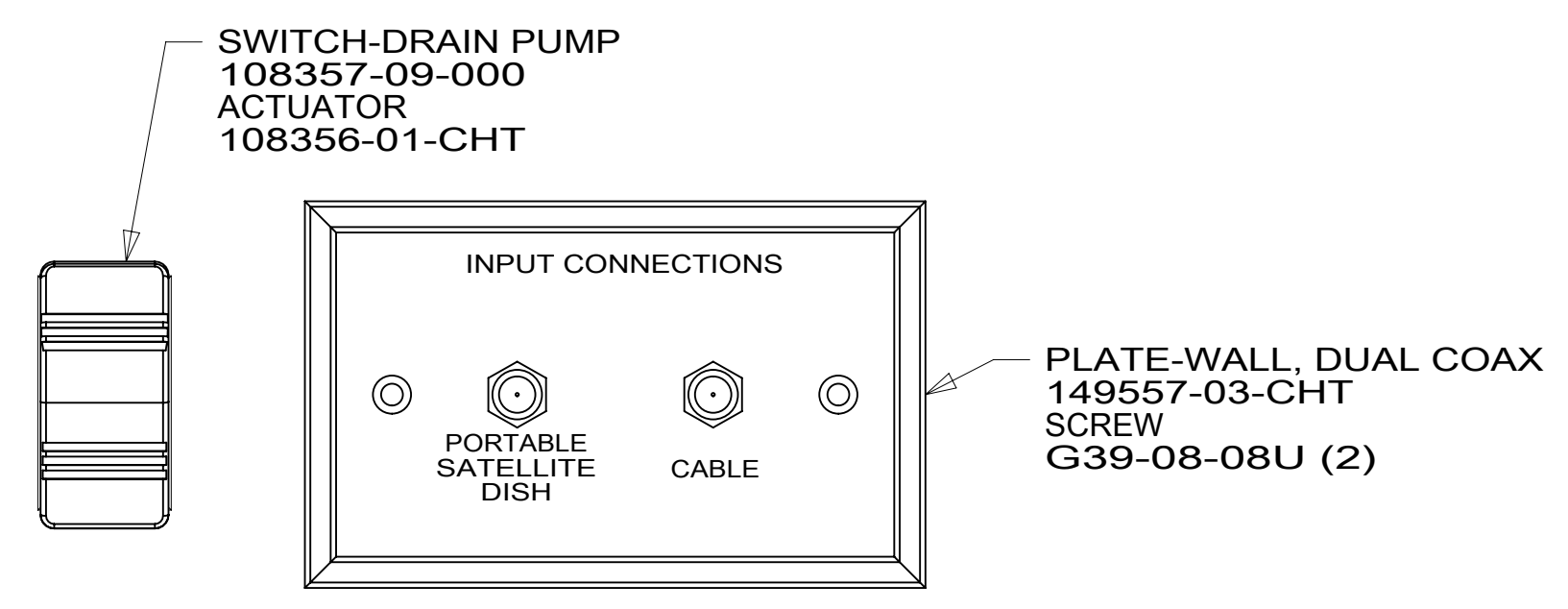

VIEW AA

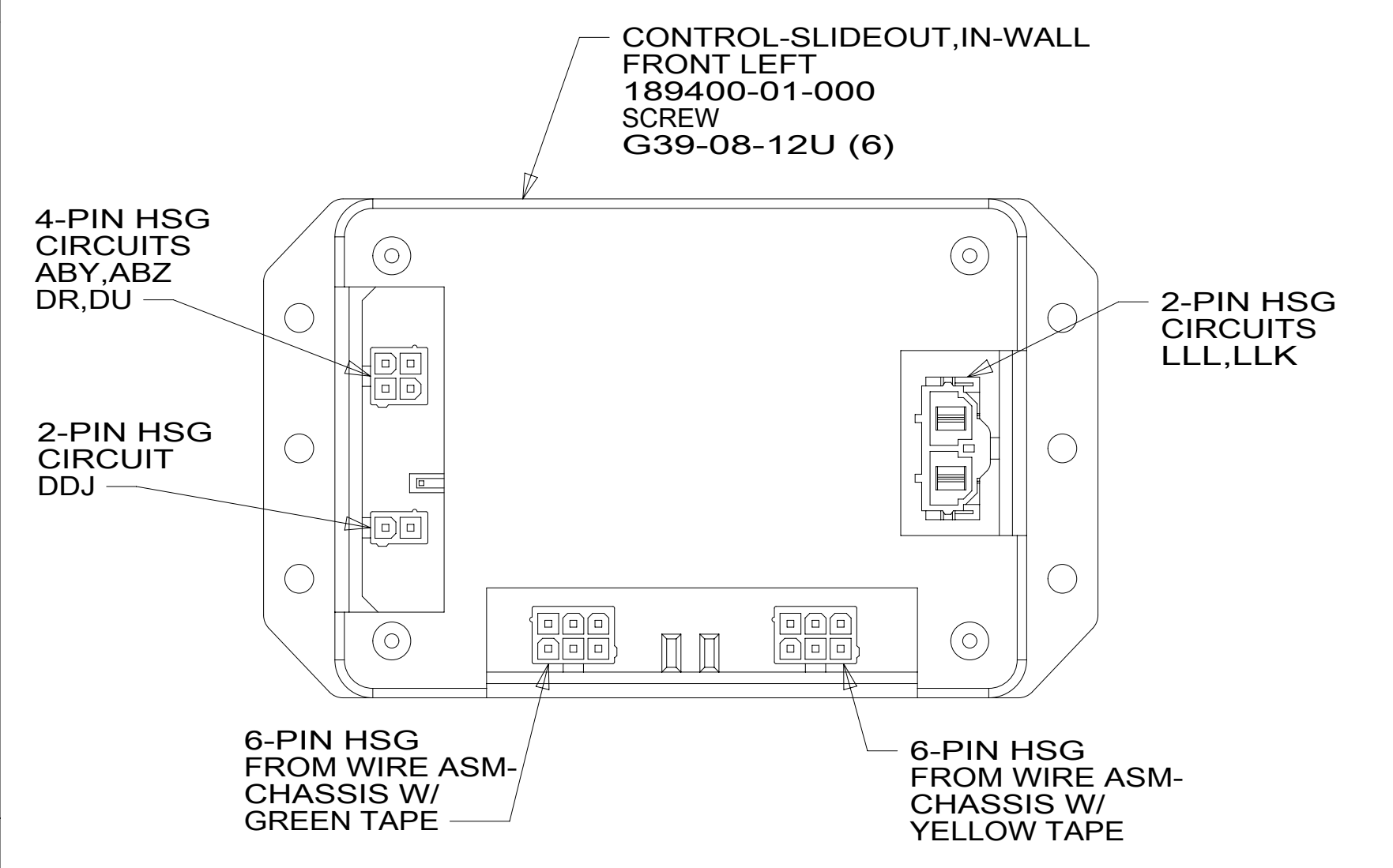

DETAIL AB

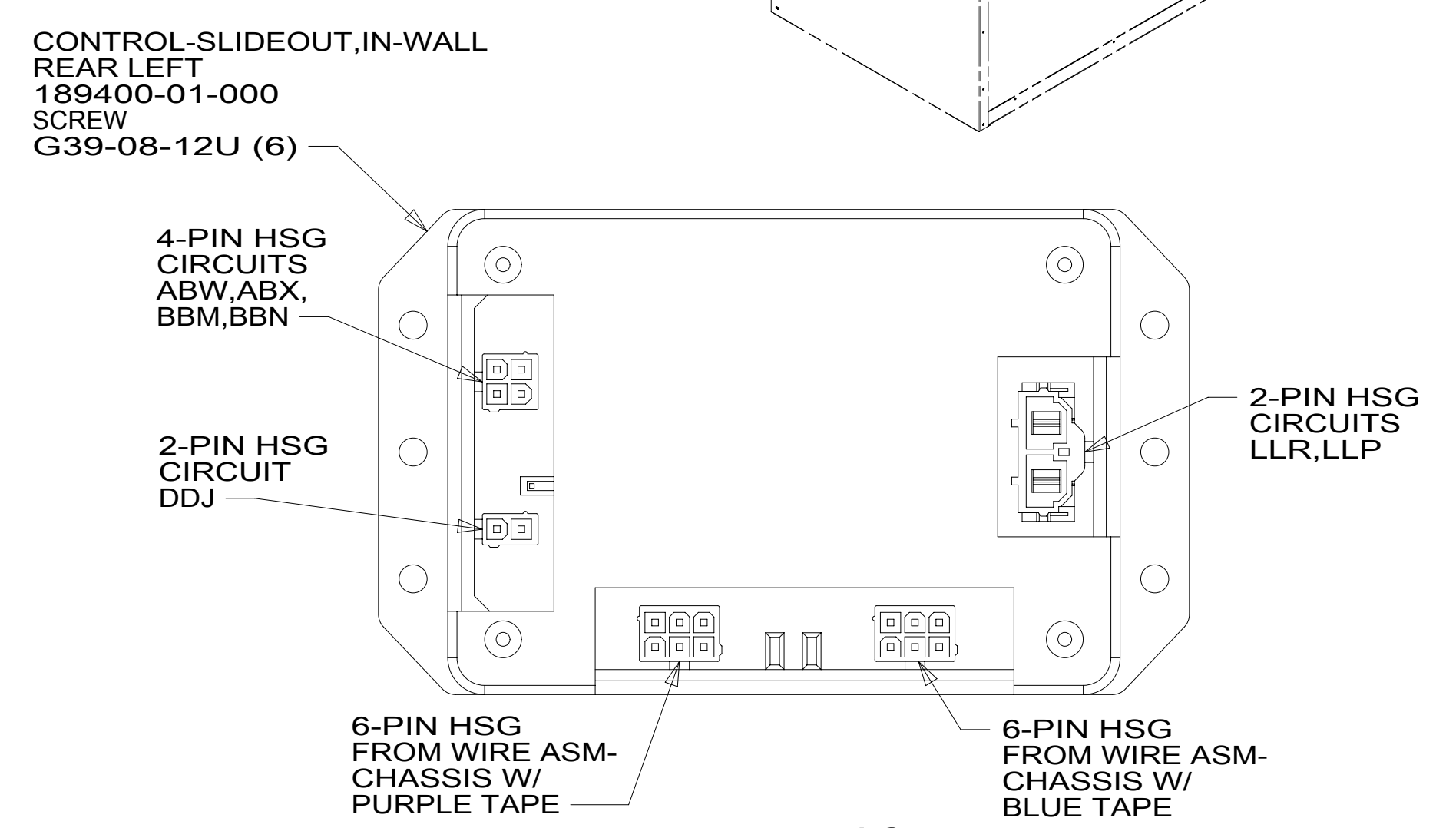
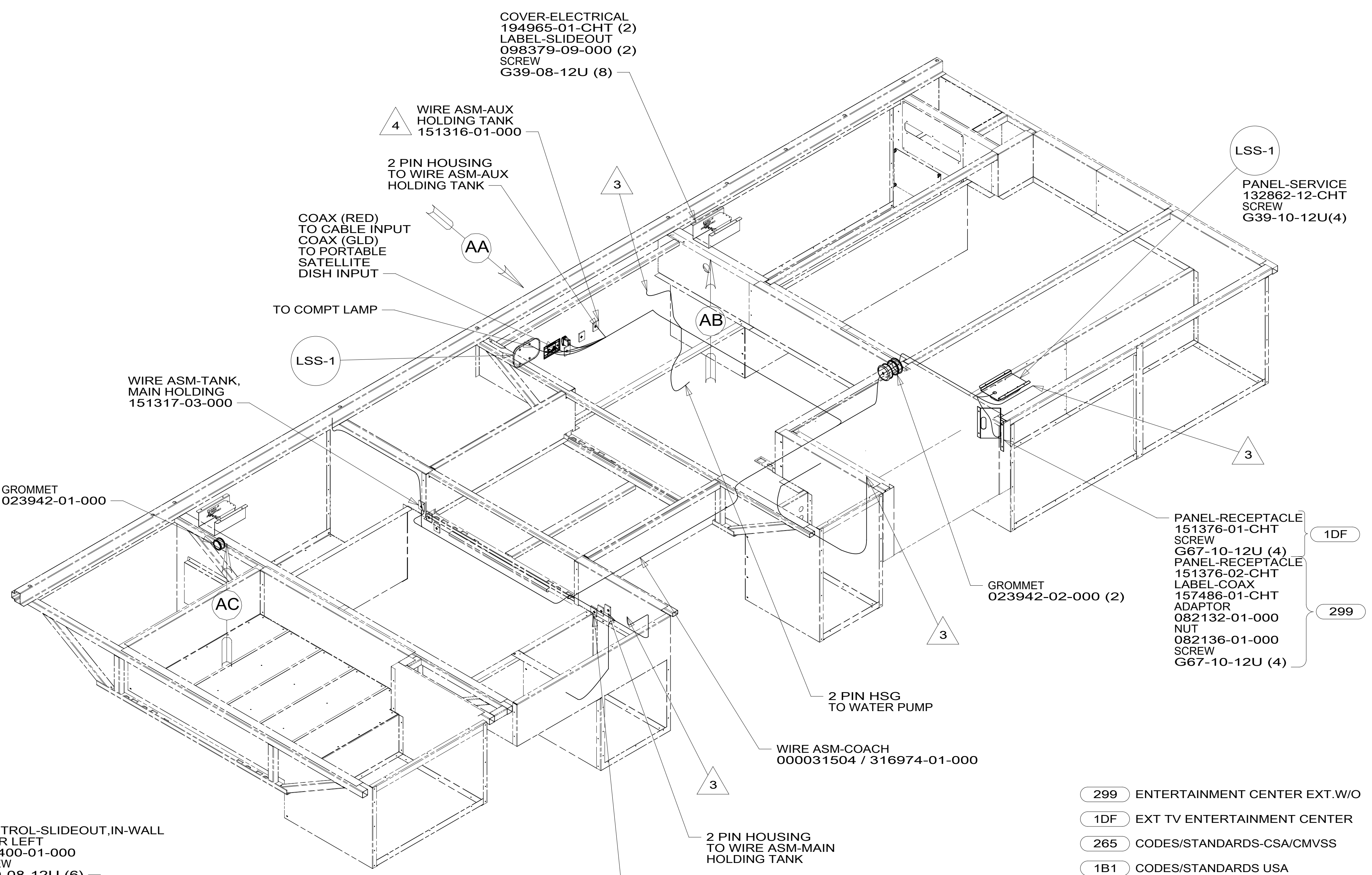

DETAIL AC

- 4 PLACE CROSS LOCATOR ON SENSORS OVER DIMPLES ON TANK.
- 3 WIRE PASSES THROUGH FLOOR IN THIS AREA.

2. ROUTE TANK SENSOR WIRES SO THEY DO NOT PASS OVER SENSORS. USE WIRE TIE MOUNT 155366-01-000 AND WIRE TIE 8343-01-000 AS NEEDED. TANK SURFACE MUST BE CLEANED USING ISOPROPYL ALCOHOL AND PRIMED WITH PRIMER 94.

1. AT MINIMUM ALL WIRES TO BE SUPPORTED AND SECURED PER CODE REQUIREMENTS. USE CLAMP 10495 OR 10497 OR WIRE TIE 8343 OR 108046 AND SCREW G67-XX-XXX OR G56-XX-XXX AS APPROPRIATE FOR INSTALLATION.

NOTES:

- 299 ENTERTAINMENT CENTER EXT. W/O
- 1DF EXT TV ENTERTAINMENT CENTER
- 265 CODES/STANDARDS-CSA/CMVSS
- 1B1 CODES/STANDARDS USA

1B1 265

**WINNEBAGO**  
COPYRIGHT 2016 WINNEBAGO INDUSTRIES, INC.

DSNR:	ALL DIMENSIONS ARE IN MILLIMETERS
DIFR:	MATERIAL:
UNSPECIFIED TOLERANCES:	
WHOLE DIM (X) :	3
ONE-PLACE (X.X) :	1.5
TWO-PLACE (X.XX) :	0.50
ANGLE :	1°
REFER TO ES0018 FOR FASTENER TIGHTENING GUIDELINES	WEIGHT: (LBS) FIRST USED: <b>17 E27PE</b>
DESCRIPTION: <b>WIRING INSTL-BODY, 12V</b>	
SHEET: 1 OF 6	ITEM/PART NO: 000027234 / 31590601000
REF:	1 14-Sep-2017

FOR ELECTRICAL TORQUE SPECIFICATIONS SEE DWG NO. 128783-01-000

FOR ELECTRICAL CALLOUTS SEE DWG NO. 121339-01-000

8 7 6 5 4 3 2 1

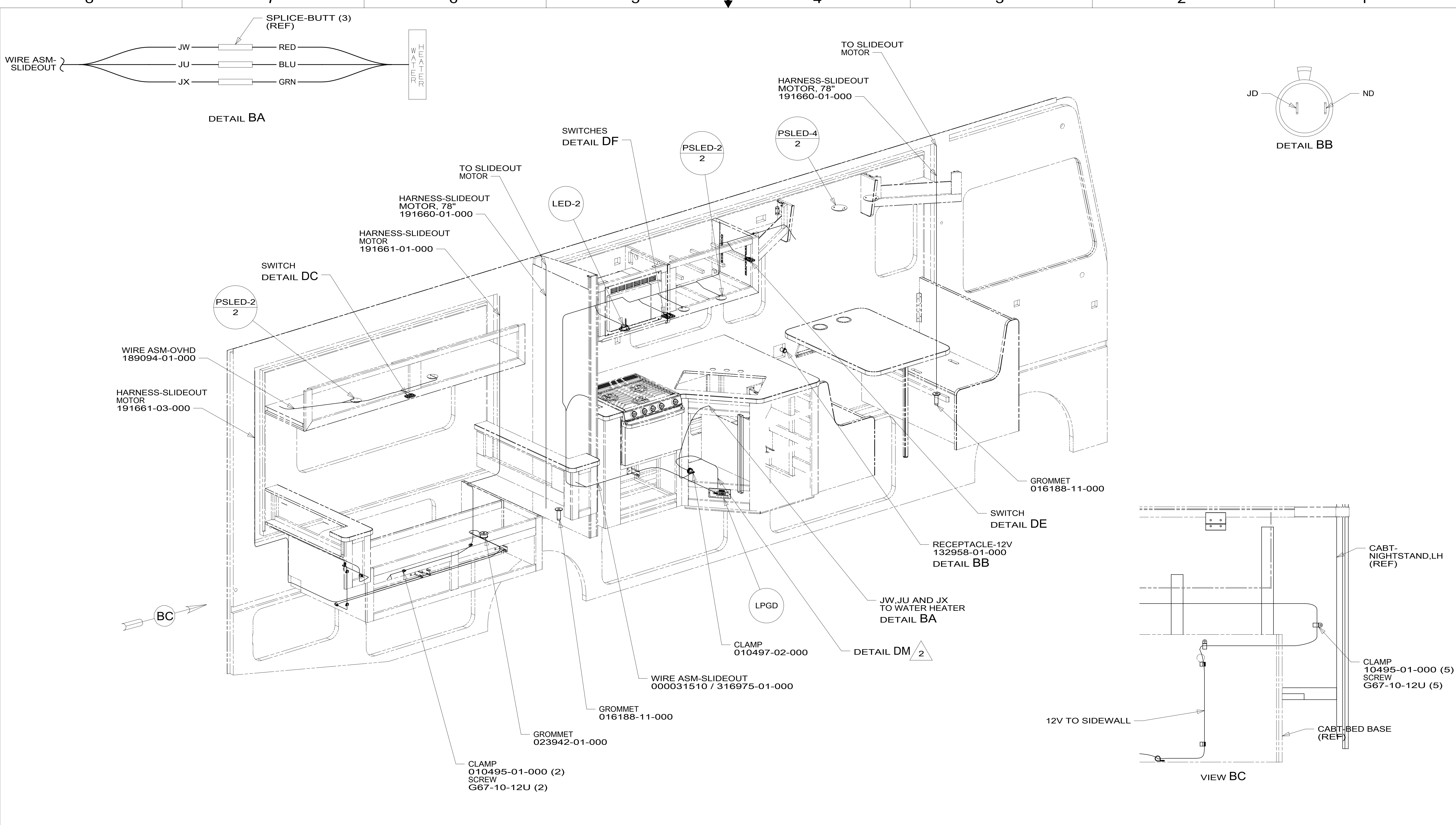

2 WIRE PASSES THROUGH FLOOR IN THIS AREA.

1. AT MINIMUM ALL WIRES TO BE SUPPORTED AND SECURED PER CODE REQUIREMENTS. USE CLAMP 10495 OR 10497 OR WIRE TIE 8343 OR 108046 AND SCREW G67-XX-XXX OR G56-XX-XXX AS APPROPRIATE FOR INSTALLATION.

NOTES:

265 CODES/STANDARDS-CSA/CMVSS  
 1B1 CODES/STANDARDS USA

FOR ELECTRICAL TORQUE SPECIFICATIONS SEE DWG NO. 128783-01-000

FOR ELECTRICAL CALLOUTS SEE DWG NO. 121339-01-000

DESCRIPTION: <b>WIRING INSTL-BODY, 12V</b>		
SHEET: 2 OF 6	ITEM/PART NO: 000027234 / 31590601000	REV

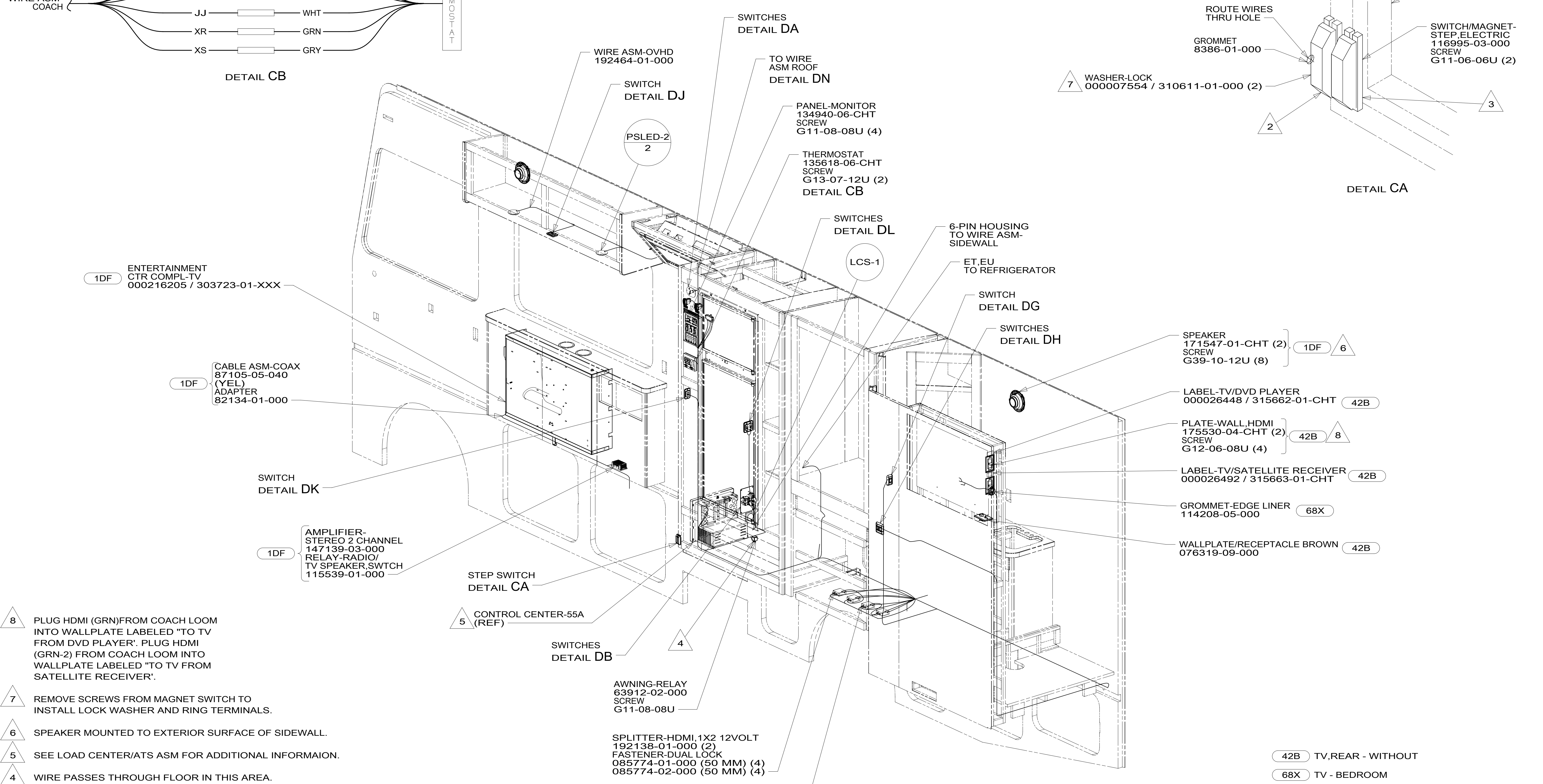
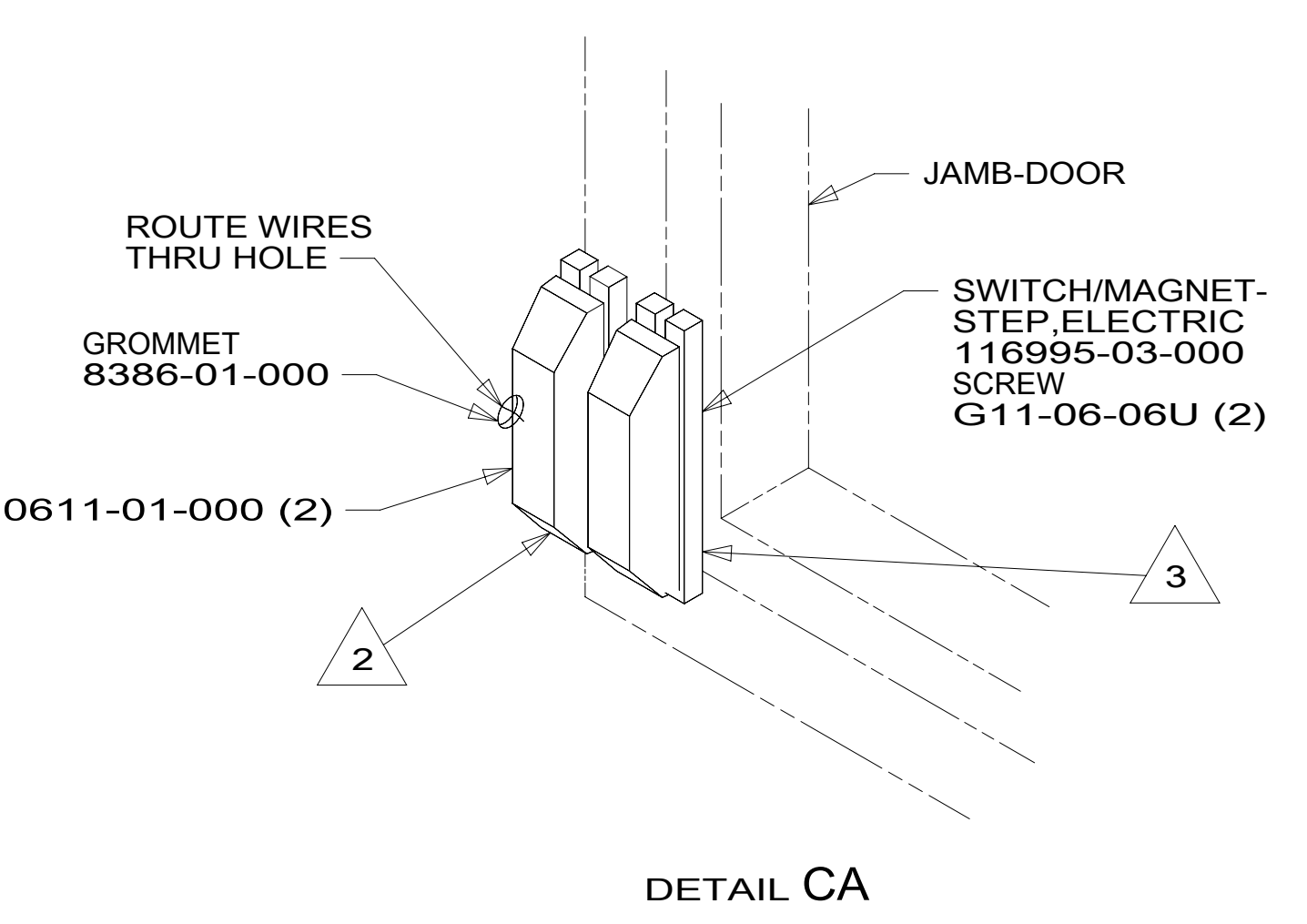
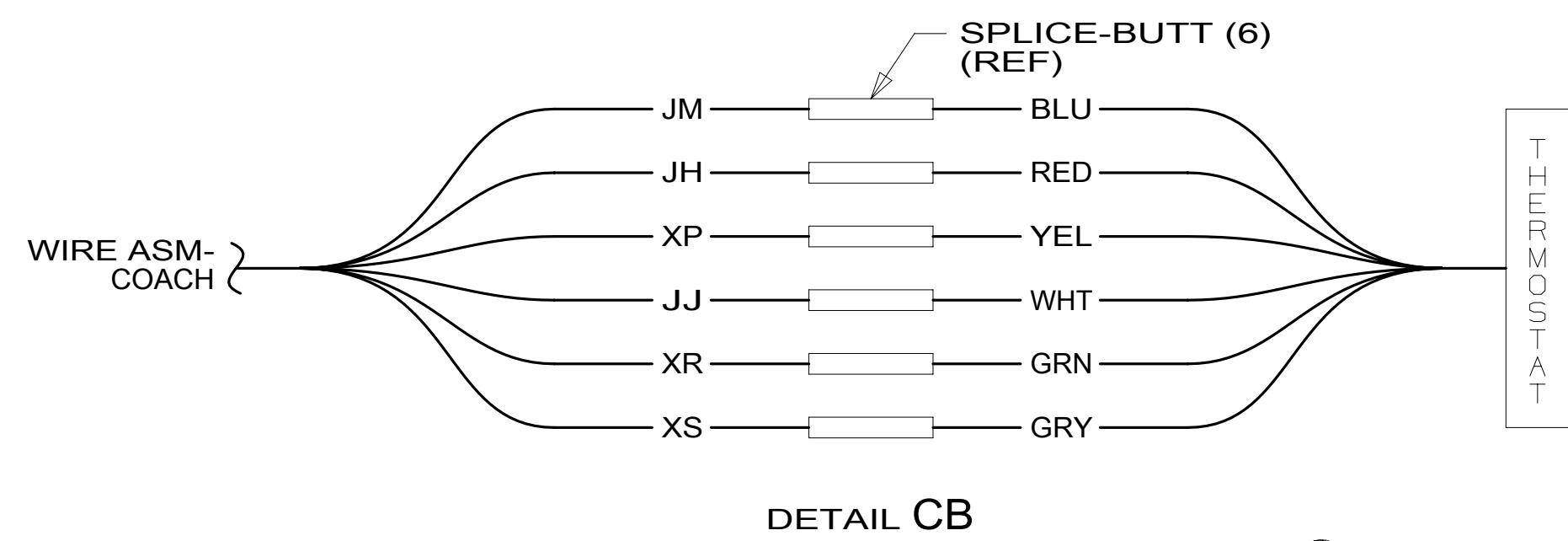

- 8 PLUG HDMI (GRN) FROM COACH LOOM INTO WALLPLATE LABELED "TO TV FROM DVD PLAYER". PLUG HDMI (GRN-2) FROM COACH LOOM INTO WALLPLATE LABELED "TO TV FROM SATELLITE RECEIVER".
- 7 REMOVE SCREWS FROM MAGNET SWITCH TO INSTALL LOCK WASHER AND RING TERMINALS.
- 6 SPEAKER MOUNTED TO EXTERIOR SURFACE OF SIDEWALL.
- 5 SEE LOAD CENTER/ATS ASM FOR ADDITIONAL INFORMATION.
- 4 WIRE PASSES THROUGH FLOOR IN THIS AREA.
- 3 MOUNT MAGNET TO SCREEN DOOR FRAME, MOUNT WITH MAGNET TOWARD SWITCH.
- 2 MOUNT SWITCH TO DOOR JAMB WITH TAPE 076322-21-000.

1. AT MINIMUM ALL WIRES TO BE SUPPORTED AND SECURED PER CODE REQUIREMENTS. USE CLAMP 10495 OR 10497 OR WIRE TIE 8343 OR 108046 AND SCREW G67-XX-XXX OR G56-XX-XXX AS APPROPRIATE FOR INSTALLATION.

NOTES:

FOR ELECTRICAL TORQUE SPECIFICATIONS SEE DWG NO. 128783-01-000

FOR ELECTRICAL CALLOUTS SEE DWG NO. 121339-01-000

- 42B TV, REAR - WITHOUT
- 68X TV - BEDROOM
- 1DF EXT TV ENTERTAINMENT CENTER
- 265 CODES/STANDARDS-CSA/CMVSS
- 1B1 CODES/STANDARDS USA

DESCRIPTION:	1B1 265	
<b>WIRING INSTL-BODY, 12V</b>		
SHEET:	ITEM/PART NO:	REV
3 OF 6	000027234 / 31590601000	

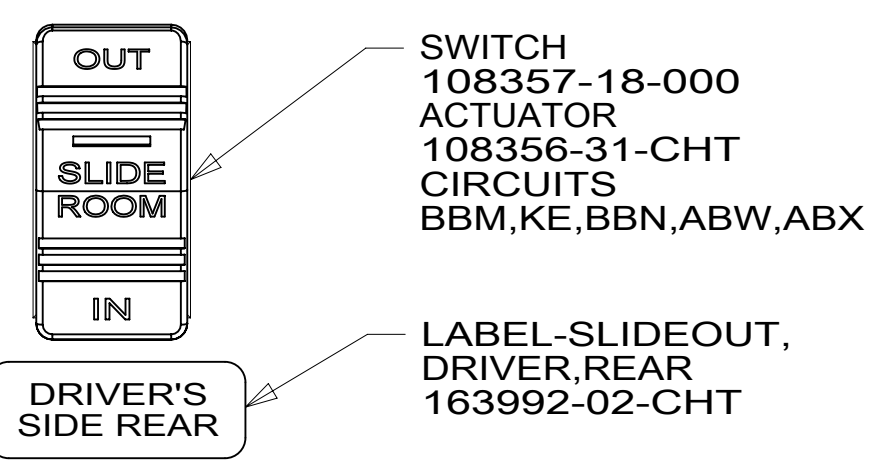
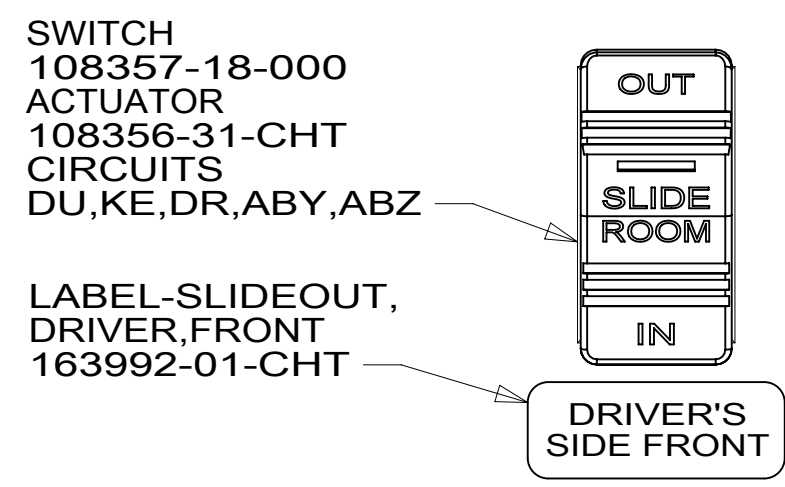
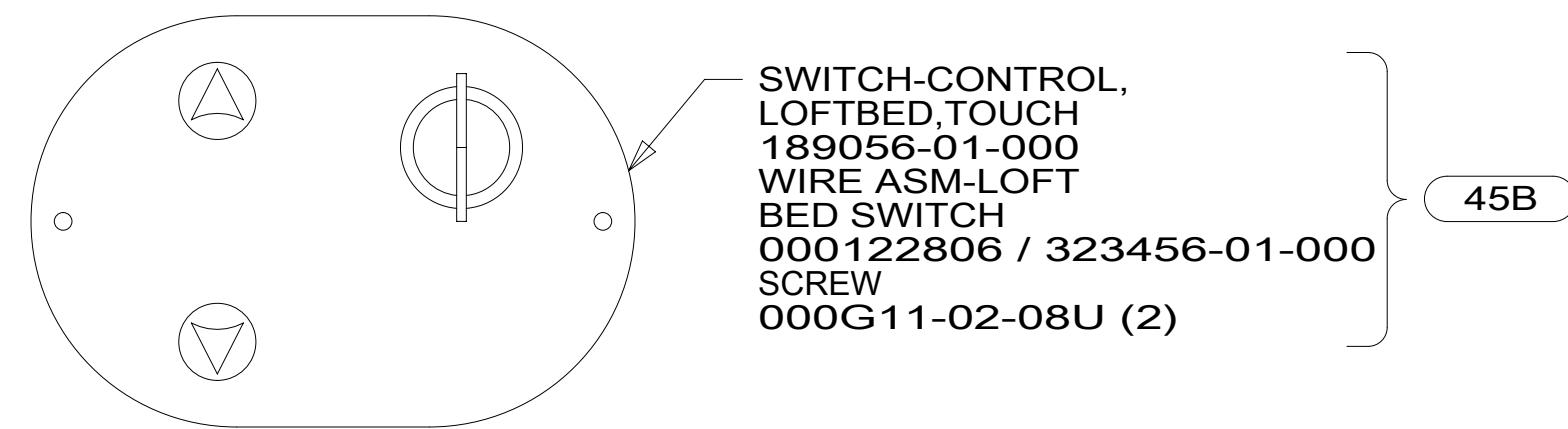

**WARNING** CRUSH HAZARD. Keep people and objects clear of the inside and the outside of the slideout room when operating. Failure to comply could result in death or serious injury.

DETAIL DA

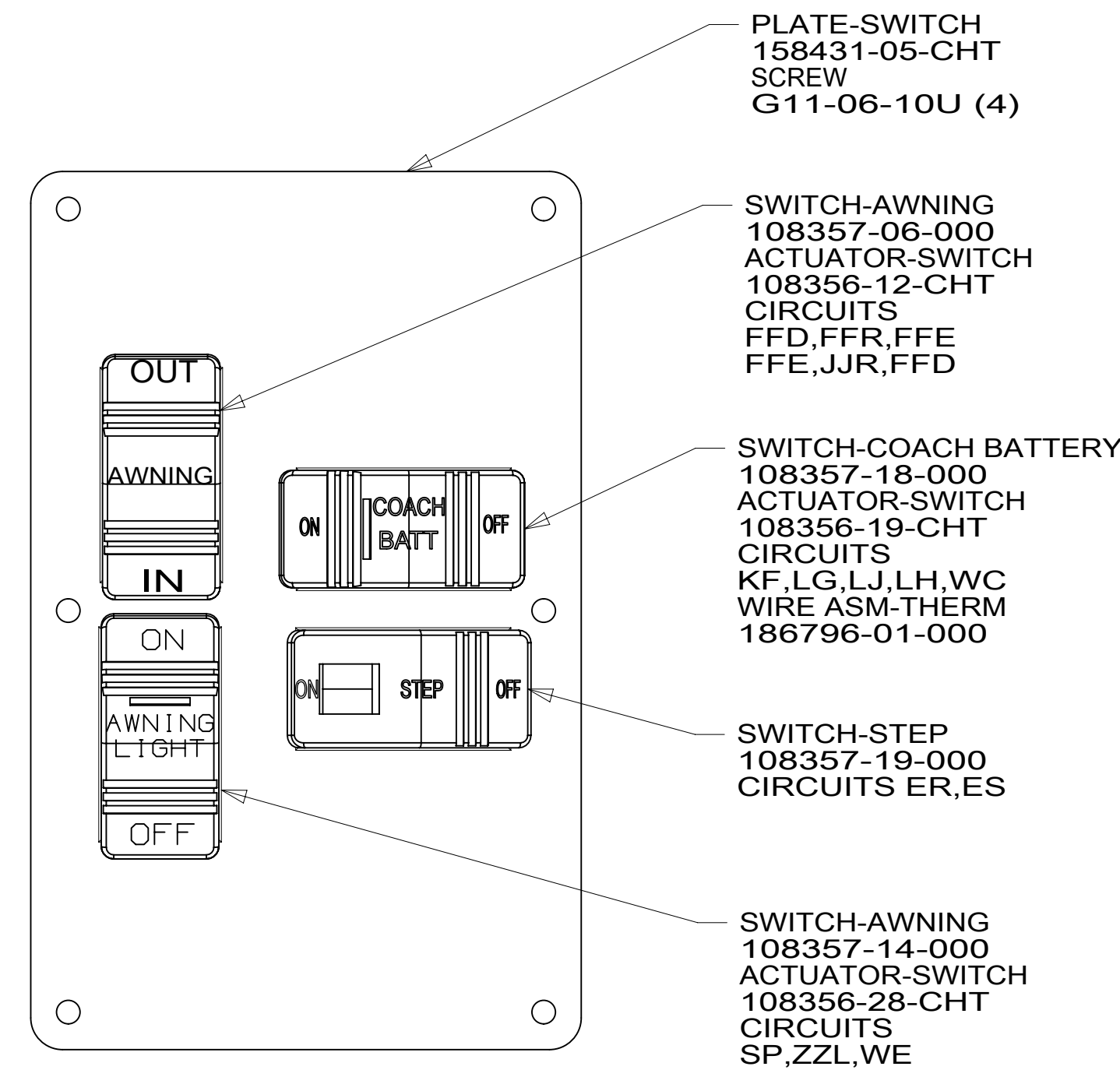
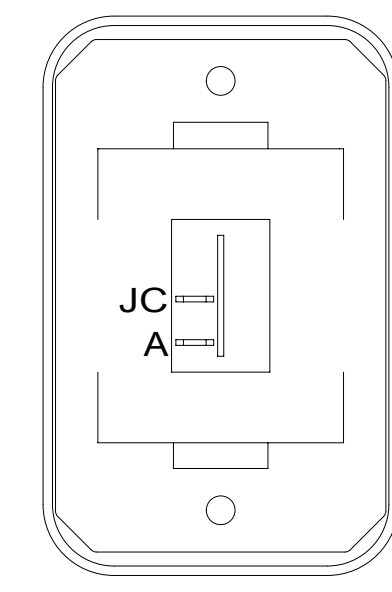
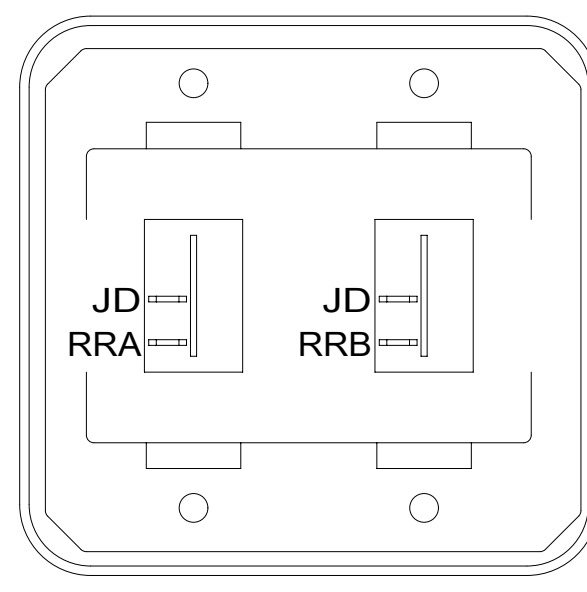
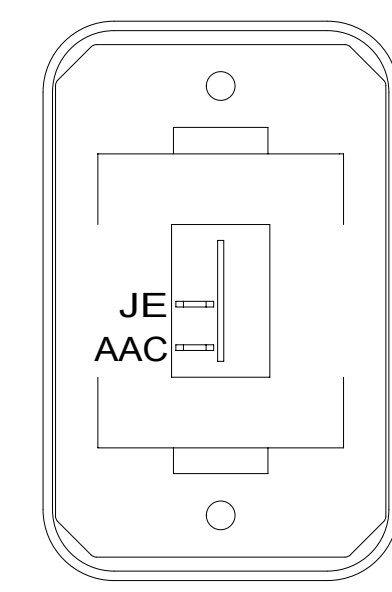
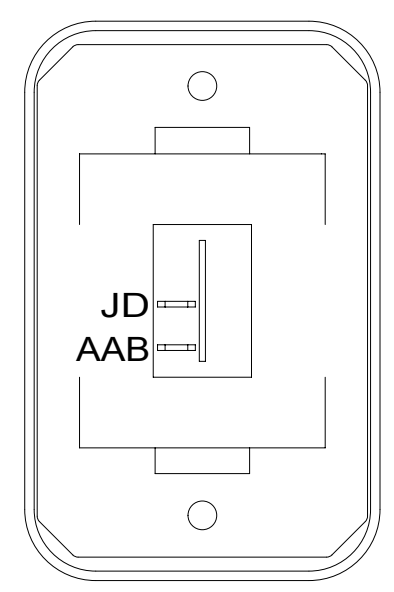
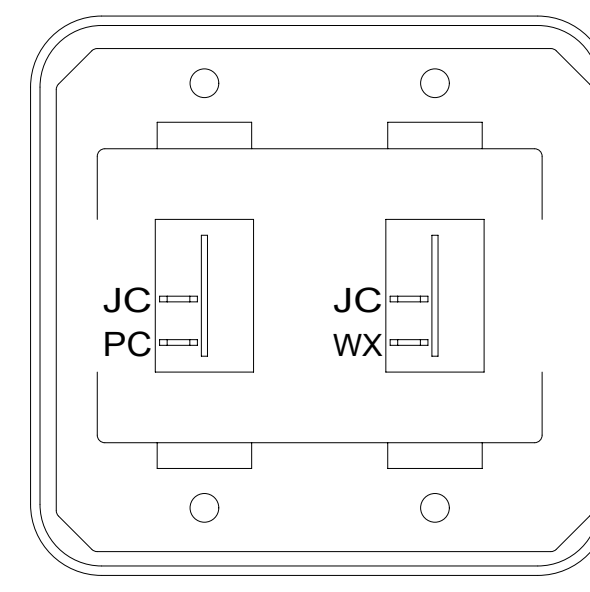
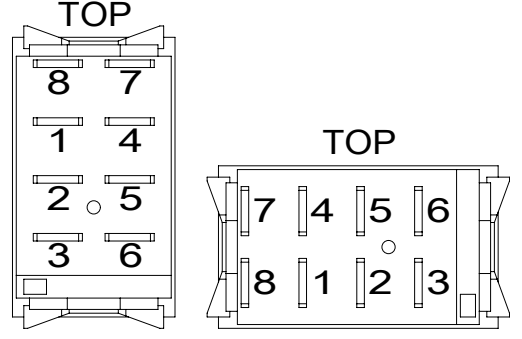
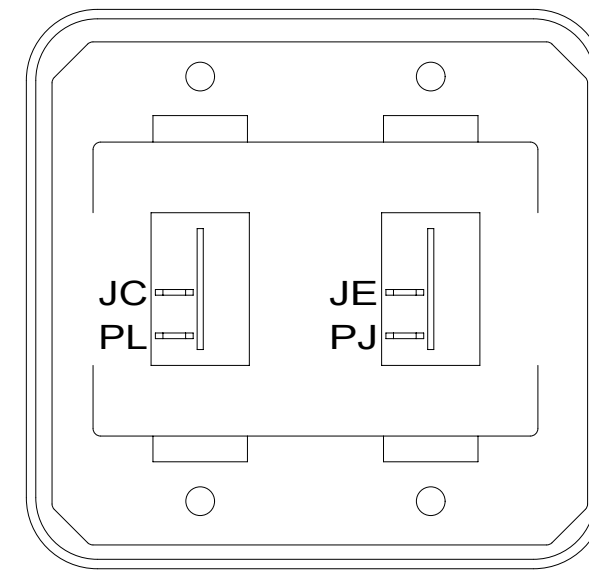
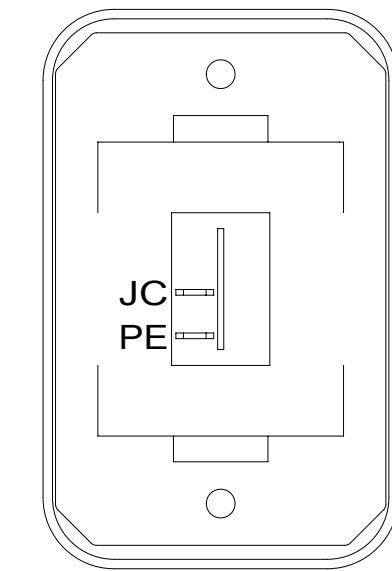
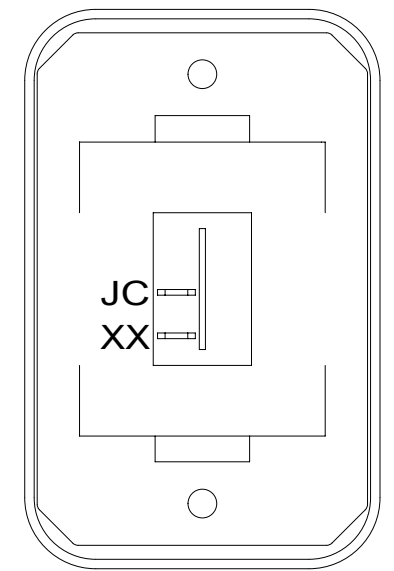

DETAIL DB 1

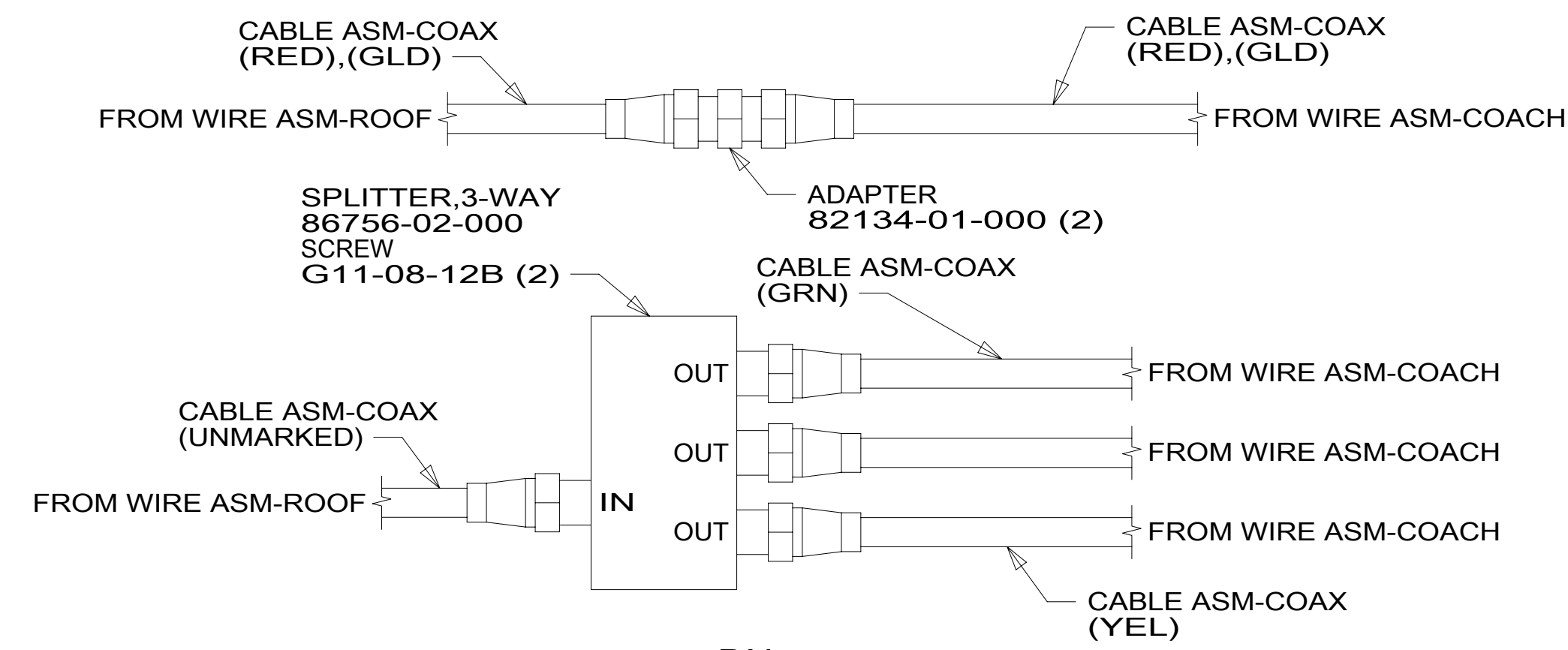
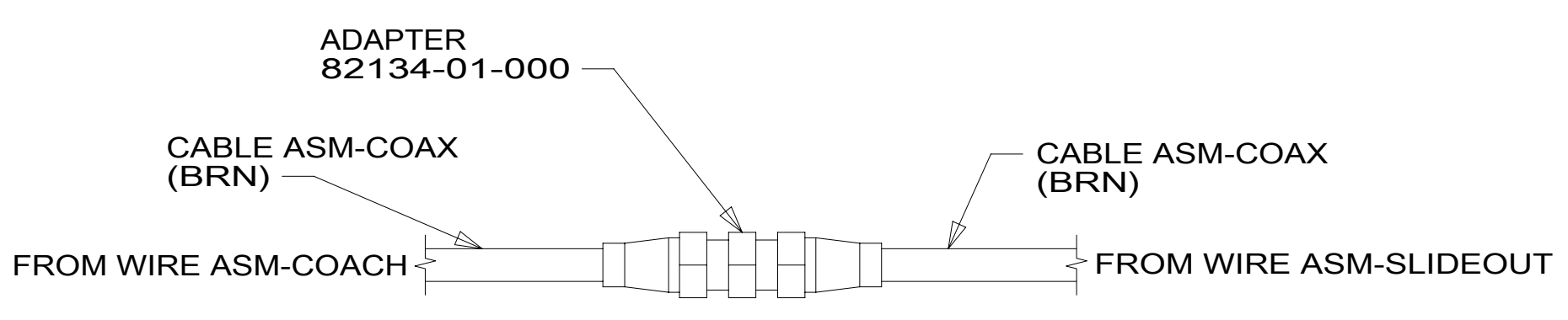

NOTES:  
1 FOR SWITCH ORIENTATION SEE DETAIL DD.

FOR ELECTRICAL  
TORQUE  
SPECIFICATIONS  
SEE DWG NO.  
128783-01-000

FOR ELECTRICAL  
CALLOUTS  
SEE DWG NO.  
121339-01-000

- 45B LOFT BED
- 299 ENTERTAINMENT CENTER EXT.W/O
- 1DF EXT TV ENTERTAINMENT CENTER
- 265 CODES/STANDARDS-CSA/CMVSS
- 1B1 CODES/STANDARDS USA

DESCRIPTION: <b>WIRING INSTL-BODY, 12V</b>		
SHEET: 4 OF 6	ITEM/PART NO: 000027234 / 31590601000	REV

8

7

6

5

4

3

2

1



D

D

C

C

B

B

A

A

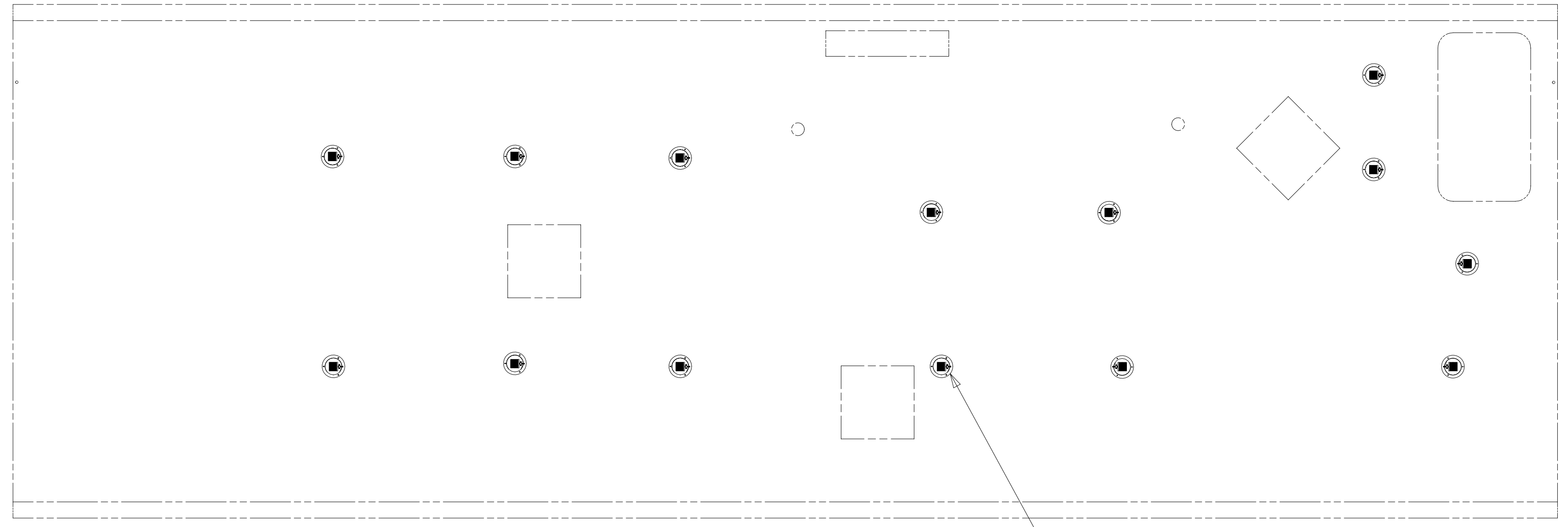

PRLED-4  
14

FOR ELECTRICAL  
TORQUE  
SPECIFICATIONS  
SEE DWG NO.  
128783-01-000

FOR  
ELECTRICAL  
CALLOUTS  
SEE DWG NO.  
121339-01-000

- 265 CODES/STANDARDS-CSA/CMVSS
- 1B1 CODES/STANDARDS USA

1B1 265

DESCRIPTION:  
**WIRING INSTL-BODY, 12V**

SHEET: 5 OF 6	ITEM/PART NO: 000027234 / 31590601000	REV
------------------	--	-----

8

7

6

5

4

3

2

1



8

7

6

5

4

3

2

1



D

D

C

C

B

B

A

A

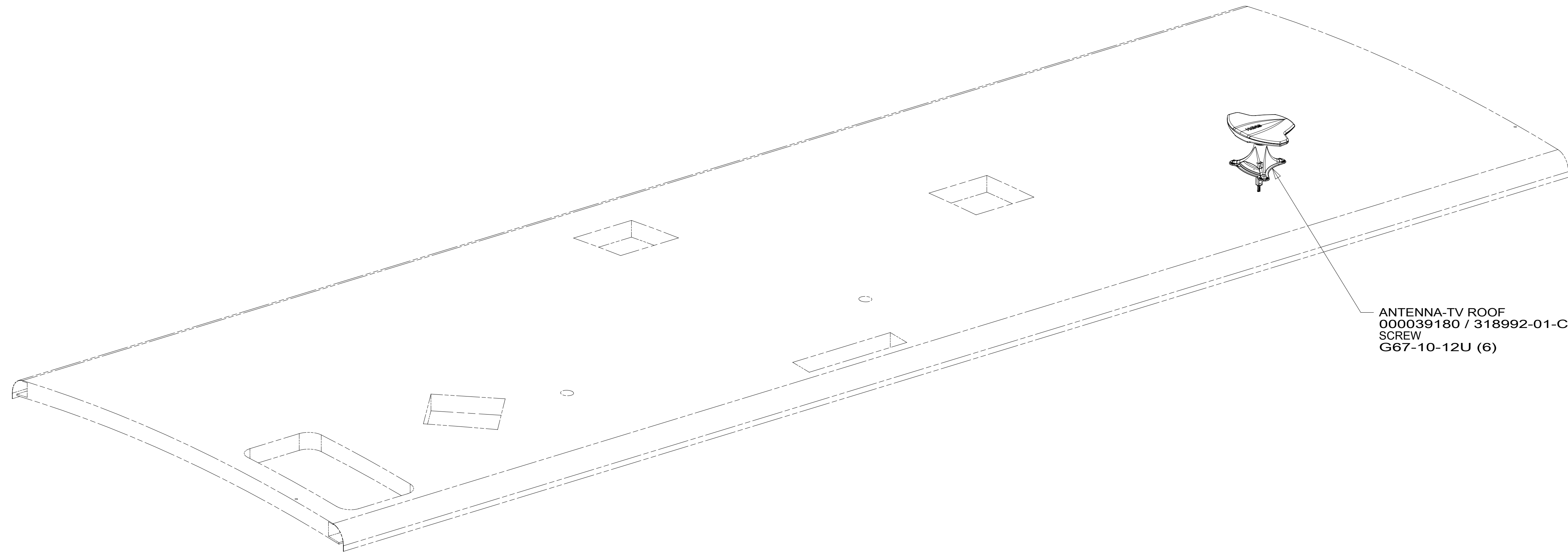

ANTENNA-TV ROOF  
 000039180 / 318992-01-CHT  
 SCREW  
 G67-10-12U (6) 1

1 SEE ANTENNA INSTALLATION MANUAL FOR CORRECT  
 INSTALLATION PROCEDURE.

NOTES:

FOR ELECTRICAL  
 TORQUE  
 SPECIFICATIONS  
 SEE DWG NO.  
 128783-01-000

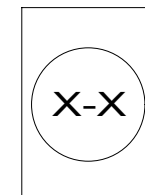

FOR  
 ELECTRICAL  
 CALLOUTS  
 SEE DWG NO.  
 121339-01-000

265 CODES/STANDARDS-CSA/CMVSS

1B1 CODES/STANDARDS USA

1B1 265

DESCRIPTION:  
**WIRING INSTL-BODY, 12V**

SHEET: <b>6 OF 6</b>	ITEM/PART NO: <b>000027234 / 31590601000</b>	REV
-------------------------	---	-----

8

7

6

5

4

3

2

1



1 14-Sep-2017