

8 7 6 5 4 3 2 1

BB

BA

LAMP ASM-PORCH
184120-01-CHT
SCREW
G68-06-10U (2)
CONNECTOR
058028-01-000 (2)

LAMP ASM-SIDEMARKER
179596-01-CHT

LAMP-MARKER,W RED LENS
195141-02-CHT
SCREW
G11-08-12U (2)

LAMP-MARKER,W AMBER LENS
195141-01-CHT
SCREW
000G11-08-12U (2)

LAMP ASM-SIDEMARKER
179596-01-CHT

LAMP-MARKER,W RED LENS
195141-02-CHT
SCREW
G11-08-12U (2)

LAMP-MARKER,W AMBER LENS
195141-01-CHT
SCREW
000G11-08-12U (2)

- 265 CODES/STANDARDS-CSA/CMVSS
- 1B1 CODES/STANDARDS USA
- 1B1 265



DSNR:		ALL DIMENSIONS ARE IN MILLIMETERS	
DFFR:		MATERIAL:	
UNSPECIFIED TOLERANCES:			
WHOLE DIM (X)	± 3		
ONE-PLACE (X.X)	± 1.5		
TWO-PLACE (X.XX)	± 0.50		
ANGLE	± 1°		
REFER TO ES0018 FOR FASTENER TIGHTENING GUIDELINES		WEIGHT: (LBS)	FIRST USED:
			17 H25P

FOR ELECTRICAL TORQUE SPECIFICATIONS SEE DWG NO. 128783-01-000

FOR ELECTRICAL CALLOUTS SEE DWG NO. 121339-01-000

WIRING INSTL-EXTERIOR LAMPS

SHEET: 1 OF 3 ITEM/PART NO: 000026839 / 31580701000 REV

REF: 1 27-Apr-2018

8 7 6 5 4 3 2 1

D

C

B

A

D

C

B

A

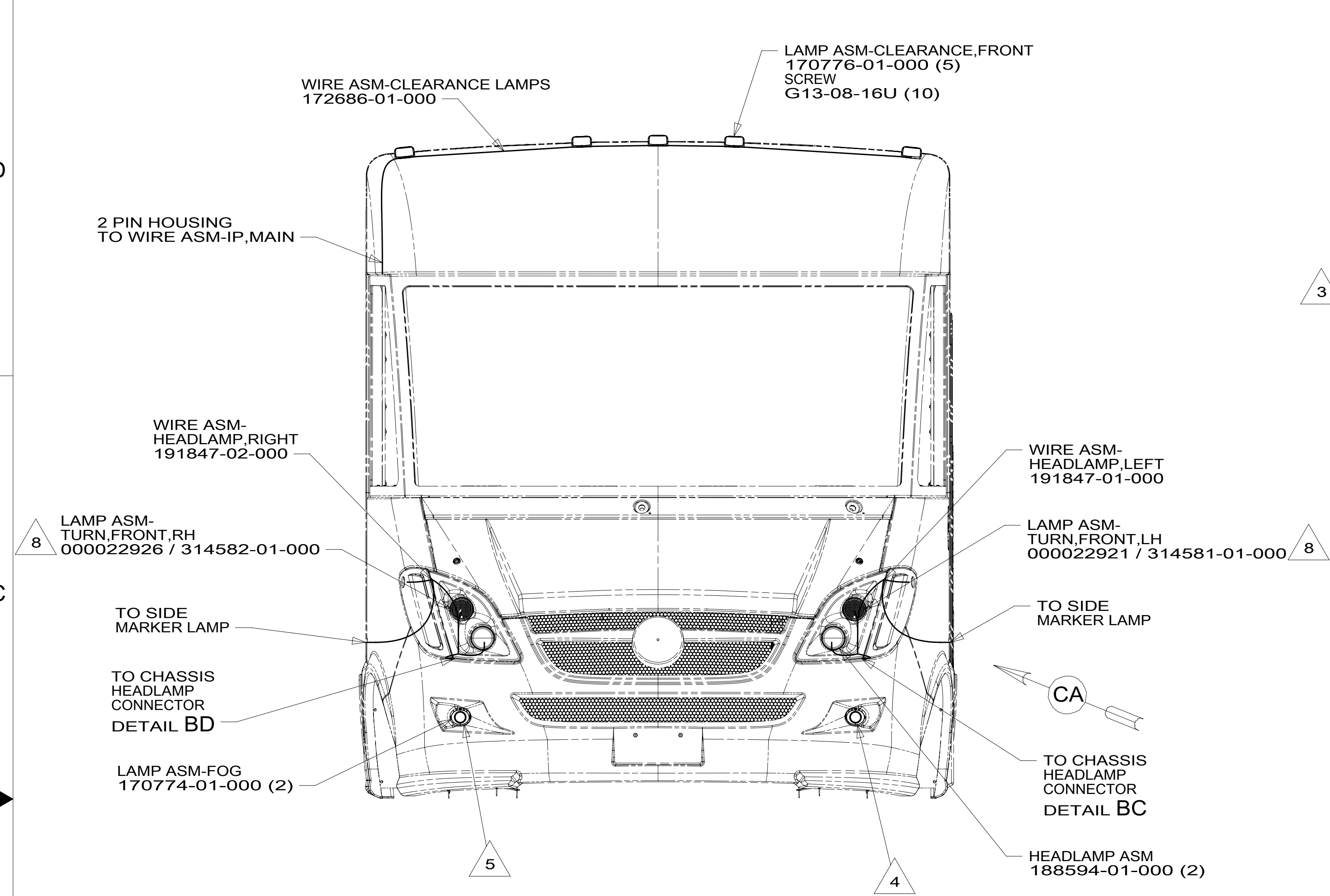

VIEW BA

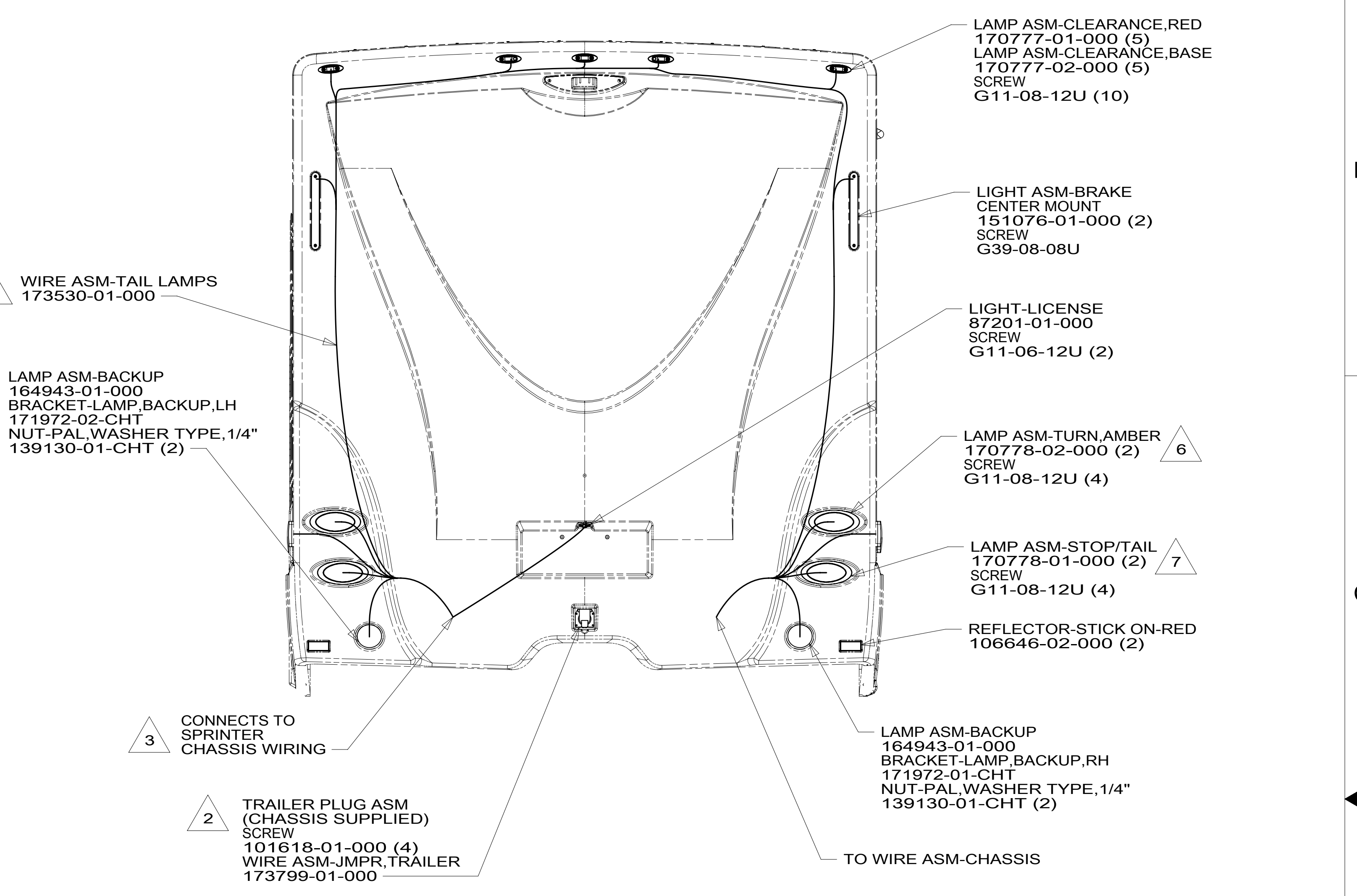

VIEW BB

- 8 REMOVE BULB FROM LAMP SOCKET AND USE IT IN SOCKET BUILT INTO WIRE ASM-HEADLAMP.
- 7 CONNECT CIRCUIT X TO RED WIRE. CONNECT CIRCUIT MM TO BLK WIRE. CONNECT CIRCUIT MS TO WHT WIRE.
- 6 CONNECT CIRCUIT SC OR SD TO RED WIRE. CONNECT CIRCUIT MS TO WHT WIRE.
- 5 CONNECT CIRCUIT MF TO GRY/YEL WIRE. CONNECT CIRCUIT AR TO BRN WIRE.
- 4 CONNECT CIRCUIT MF TO GRY/PUR WIRE. CONNECT CIRCUIT AR TO BRN WIRE.
- 3 REMOVE EXTENSION LOOMS THAT ARE SUPPLIED WITH CHASSIS. THE CHASSIS IS SUPPLIED WITH TWO 7-PIN CONNECTORS ALONG THE LEFT SIDE FRAME RAIL. THE CHASSIS WIRING WITH THE TWO 7-PIN CONNECTORS HAS A LONGER DROP AND A SHORTER DROP. ATTACH THE LONGER DROP TO THE WIRE ASM-TAILLAMP CONNECTOR WITH ONLY 2 PINS IN IT. ATTACH THE SHORTER DROP TO THE WIRE ASM-TAILLAMP CONNECTOR WITH 5 PINS.
- 2 SECURE WIRE BELOW COACH WITH CLAMP 10495-01-000 AND SCREW G67-10-12U.
- 1 CUT 14 POSITION CONNECTOR FROM CHASSIS WIRING. SPLICE TO WIRE ASM-HEADLAMP AS SHOWN. TAPE BACK ANY UNUSED WIRES.

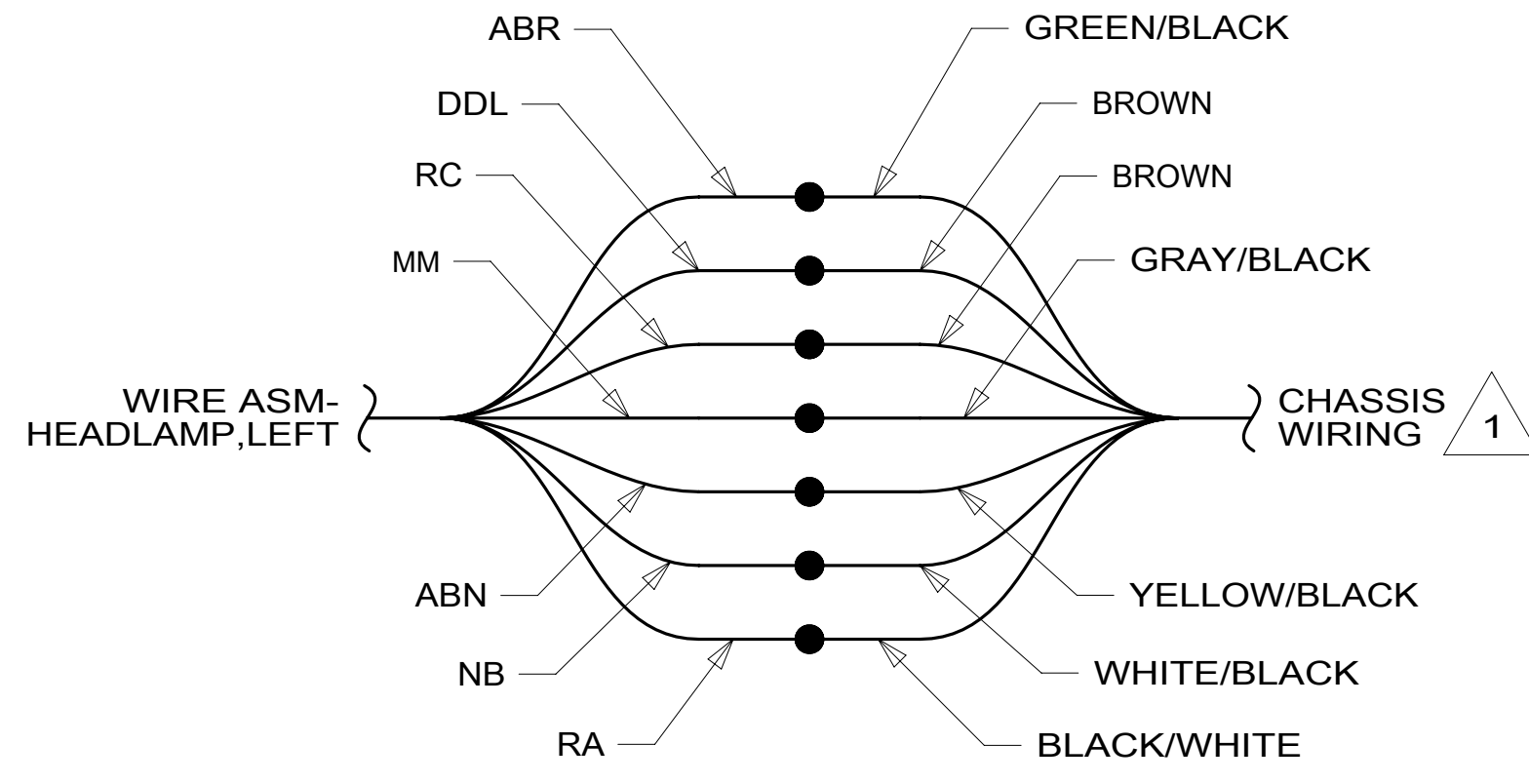

DETAIL BC

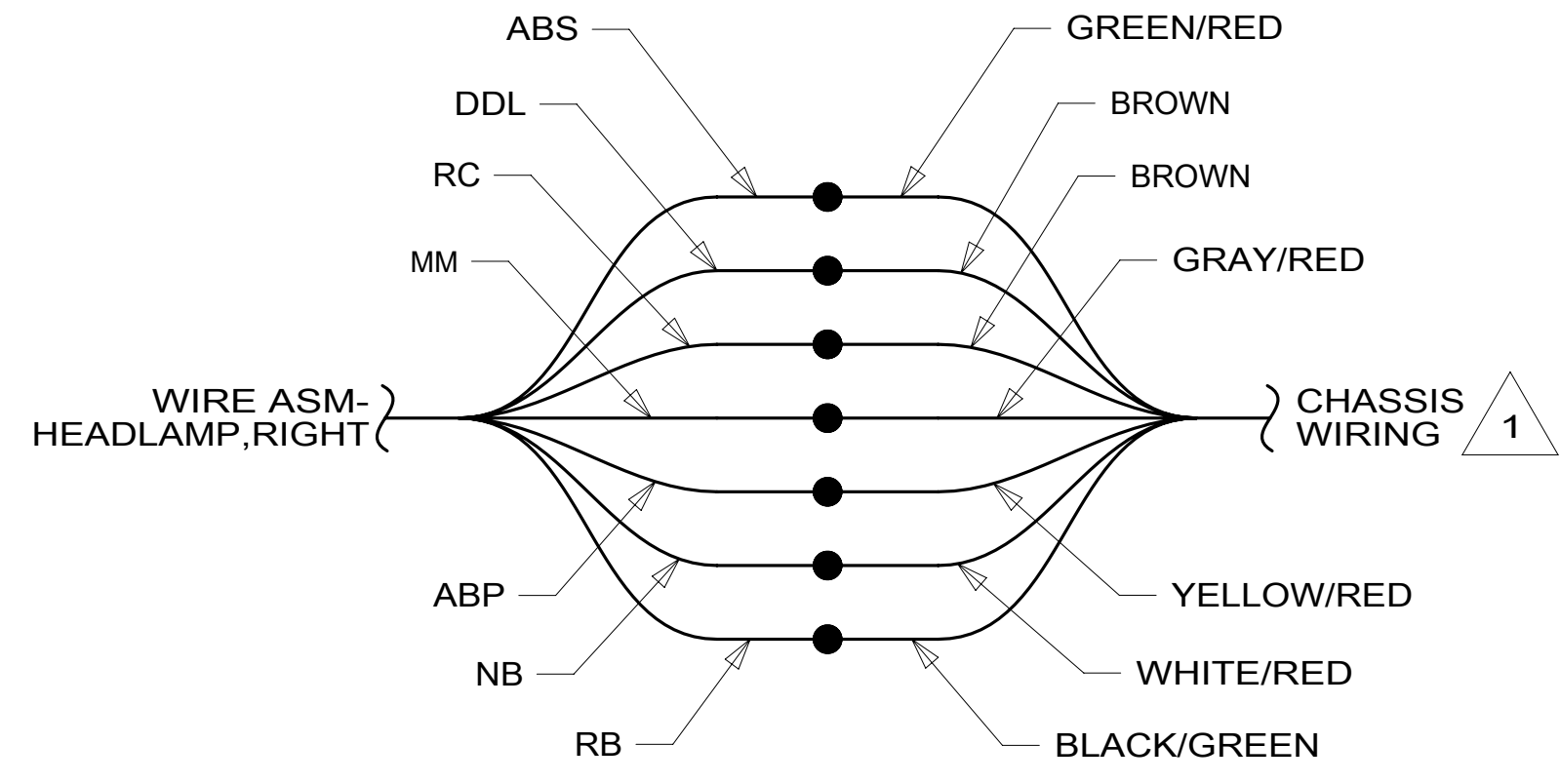

DETAIL BD

NOTES:

FOR ELECTRICAL TORQUE SPECIFICATIONS SEE DWG NO. 128783-01-000

FOR ELECTRICAL CALLOUTS SEE DWG NO. 121339-01-000

265 CODES/STANDARDS-CSA/CMVSS
1B1 CODES/STANDARDS USA

DESCRIPTION:	1B1 265	
WIRING INSTL-EXTERIOR LAMPS		
SHEET:	ITEM/PART NO:	REV
2 OF 3	000026839 / 31580701000	

8 7 6 5 4 3 2 1

D
C
B
A

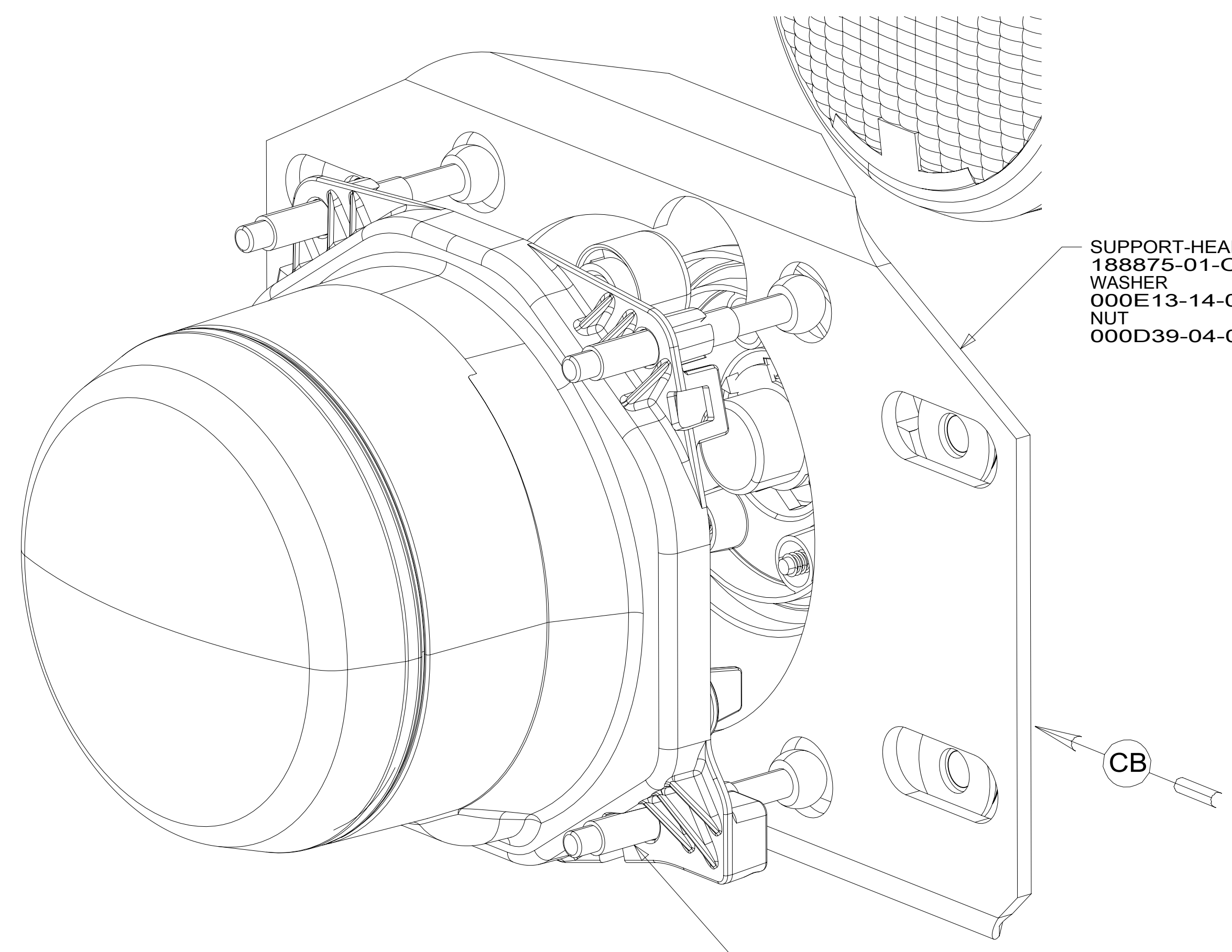

SUPPORT-HEADLAMP
188875-01-CHT (2)
WASHER
000E13-14-00U (8)
NUT
000D39-04-00U (8)

REMOVE STUD AND REINSTALL
WITH BALL END TOWARD
BACK OF HEADLAMP

VIEW CA

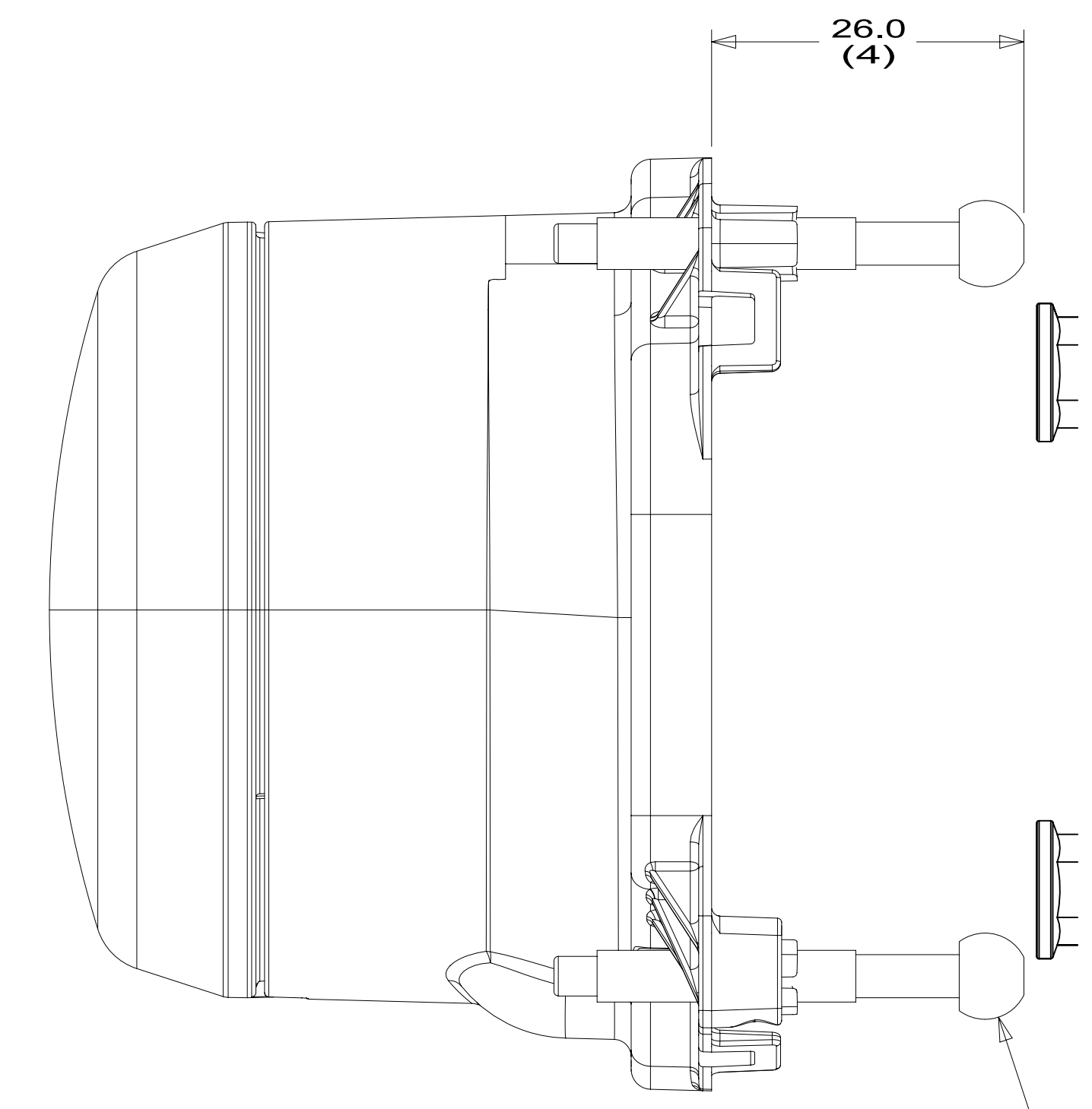

26.0
(4)

REMOVE STUD AND REINSTALL
WITH BALL END TOWARD
BACK OF HEADLAMP

VIEW CB
(2 PLACES)

265 CODES/STANDARDS-CSA/CMVSS
1B1 CODES/STANDARDS USA

FOR ELECTRICAL
TORQUE
SPECIFICATIONS
SEE DWG NO.
128783-01-000

FOR
ELECTRICAL
CALLOUTS
SEE DWG NO.
121339-01-000

DESCRIPTION:	
1B1 265	
WIRING INSTL-EXTERIOR LAMPS	
SHEET:	ITEM/PART NO:
3 OF 3	000026839 / 31580701000
REV	

8 7 6 5 4 3 2 1 27-Apr-2018