

8 7 6 5 4 3 2 1

D
C
B
A

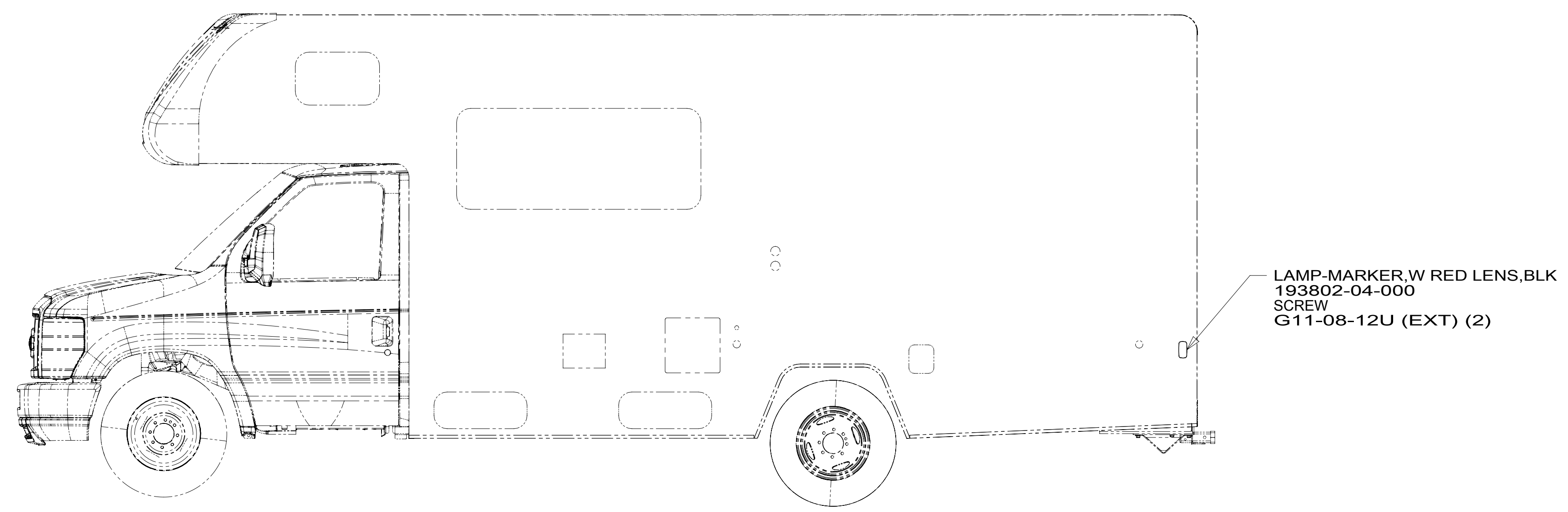

- 265 CODES/STANDARDS-CSA/CMVSS
- 1B1 CODES/STANDARDS USA
- 1B1 265

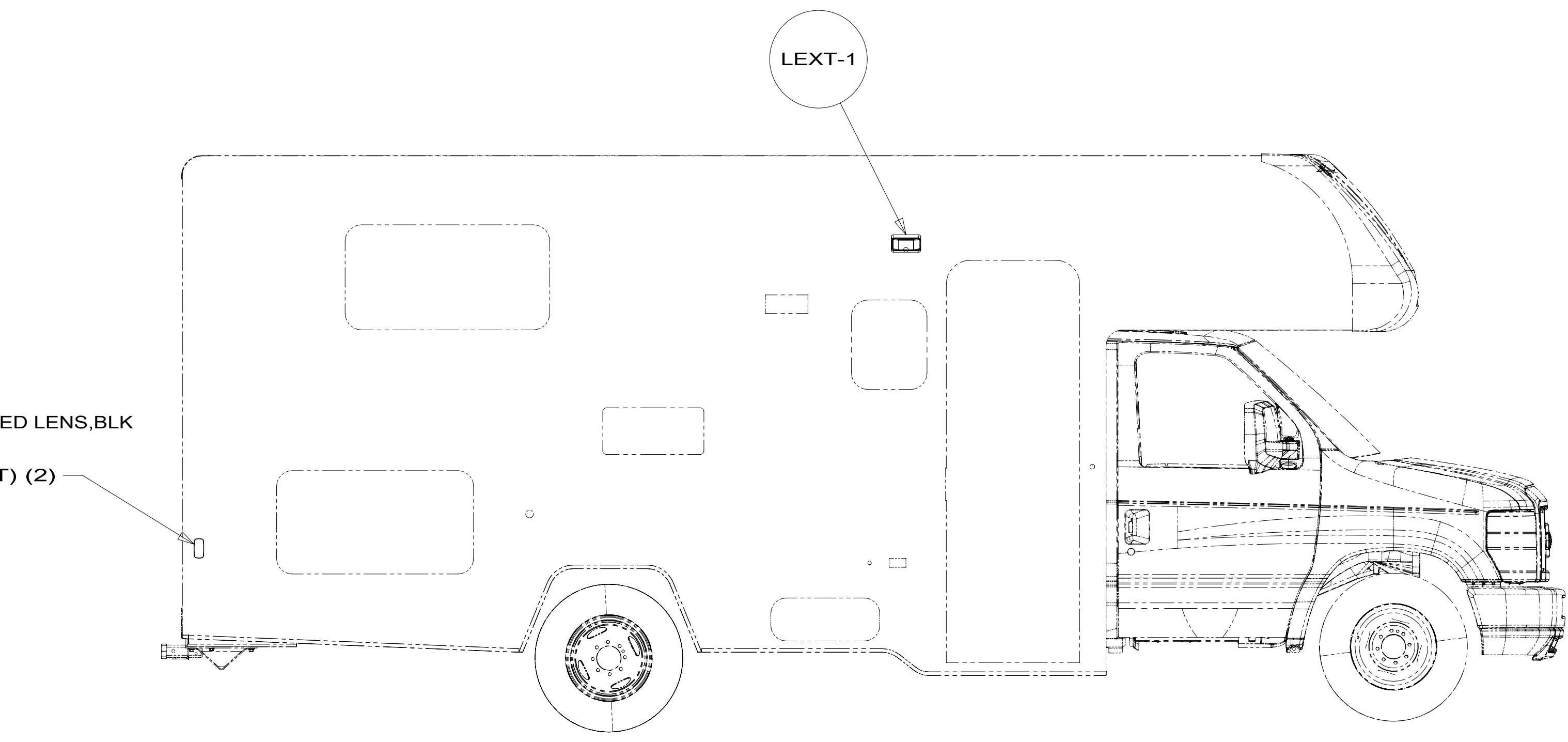
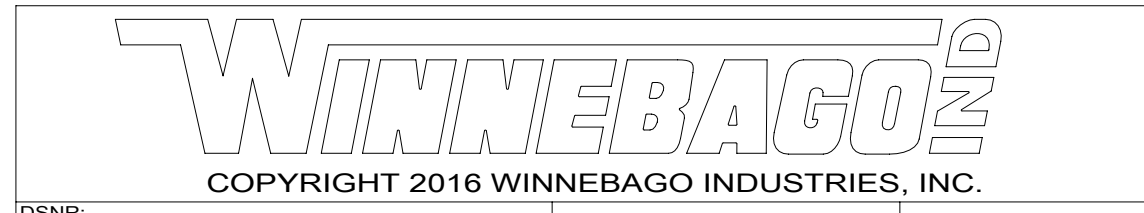

DSNR:		ALL DIMENSIONS ARE IN MILLIMETERS	
DFFR:		MATERIAL:	
UNSPECIFIED TOLERANCES:			
WHOLE DIM (X)	± 3		
ONE-PLACE (X.X)	± 1.5		
TWO-PLACE (X.XX)	± 0.50		
ANGLE	± 1°		
REFER TO ES0018 FOR FASTENER TIGHTENING GUIDELINES		WEIGHT: (LBS)	FIRST USED:
			17 322R

FOR ELECTRICAL TORQUE SPECIFICATIONS SEE DWG NO. 128783-01-000

FOR ELECTRICAL CALLOUTS SEE DWG NO. 121339-01-000

DESCRIPTION:		
WIRING INSTL-EXTERIOR LAMPS		
SHEET:	ITEM/PART NO.:	REV:
1 OF 2	000026418 / 31563401000	
REF:		
		1 05-Apr-2017

8 7 6 5 4 3 2 1

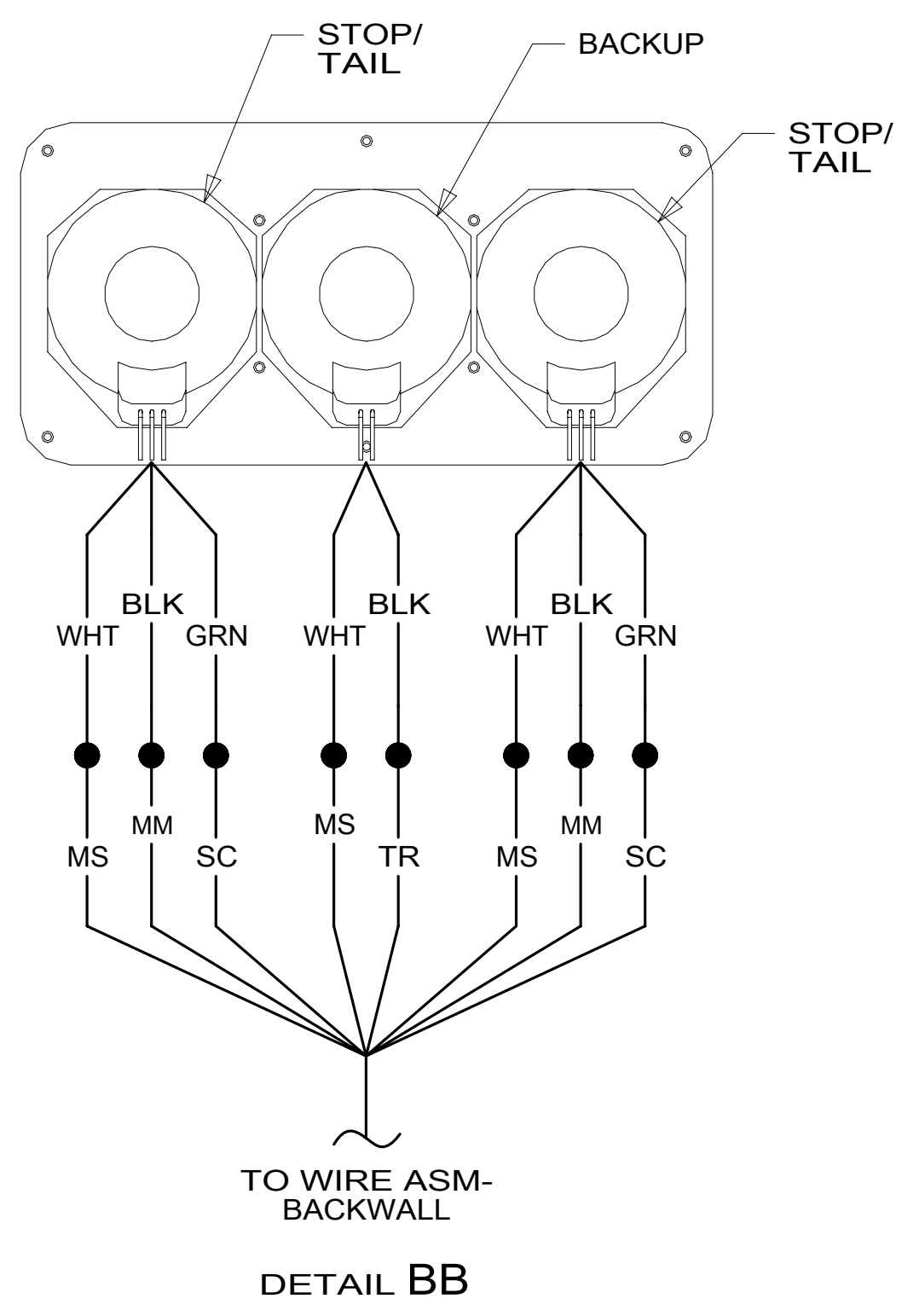
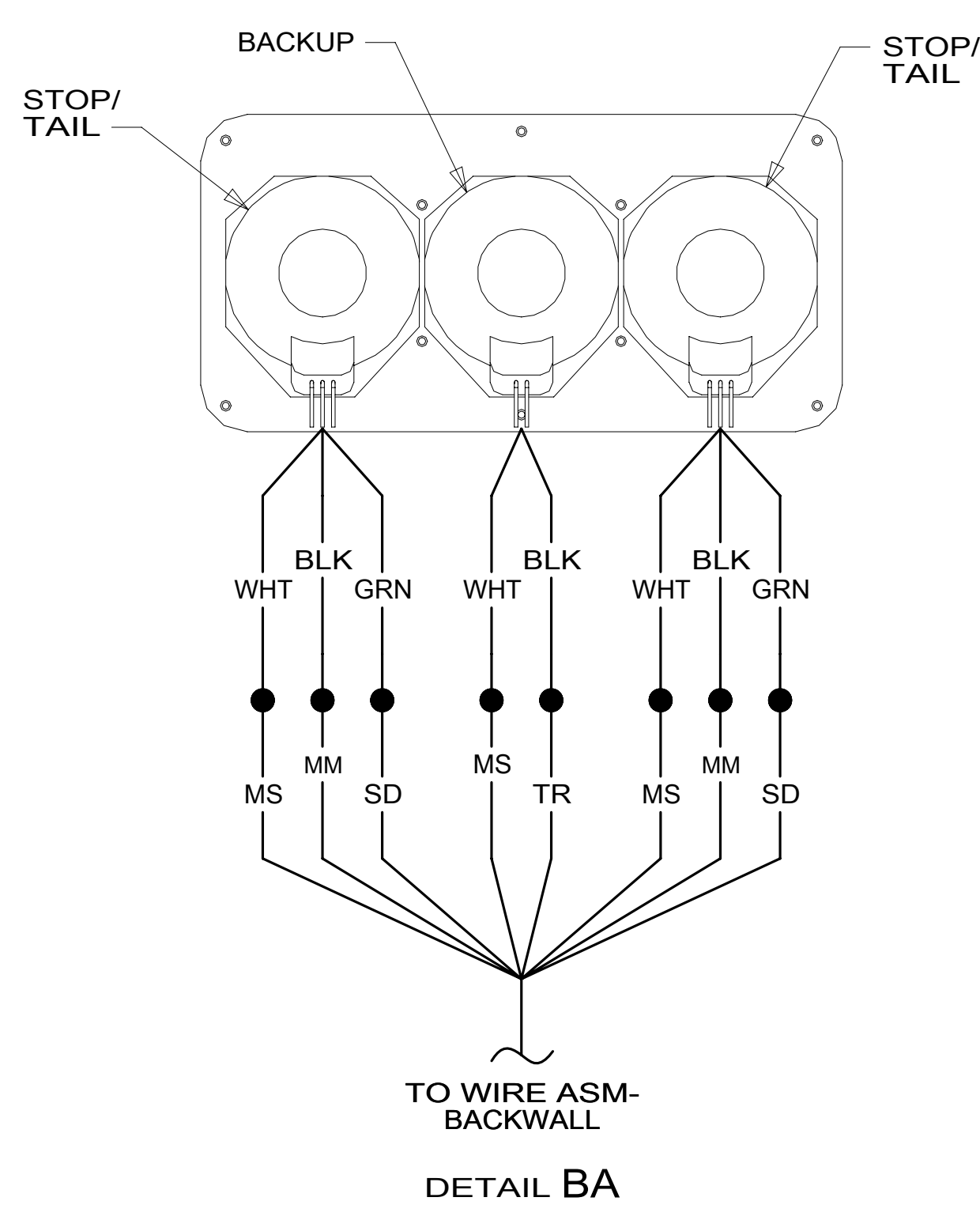
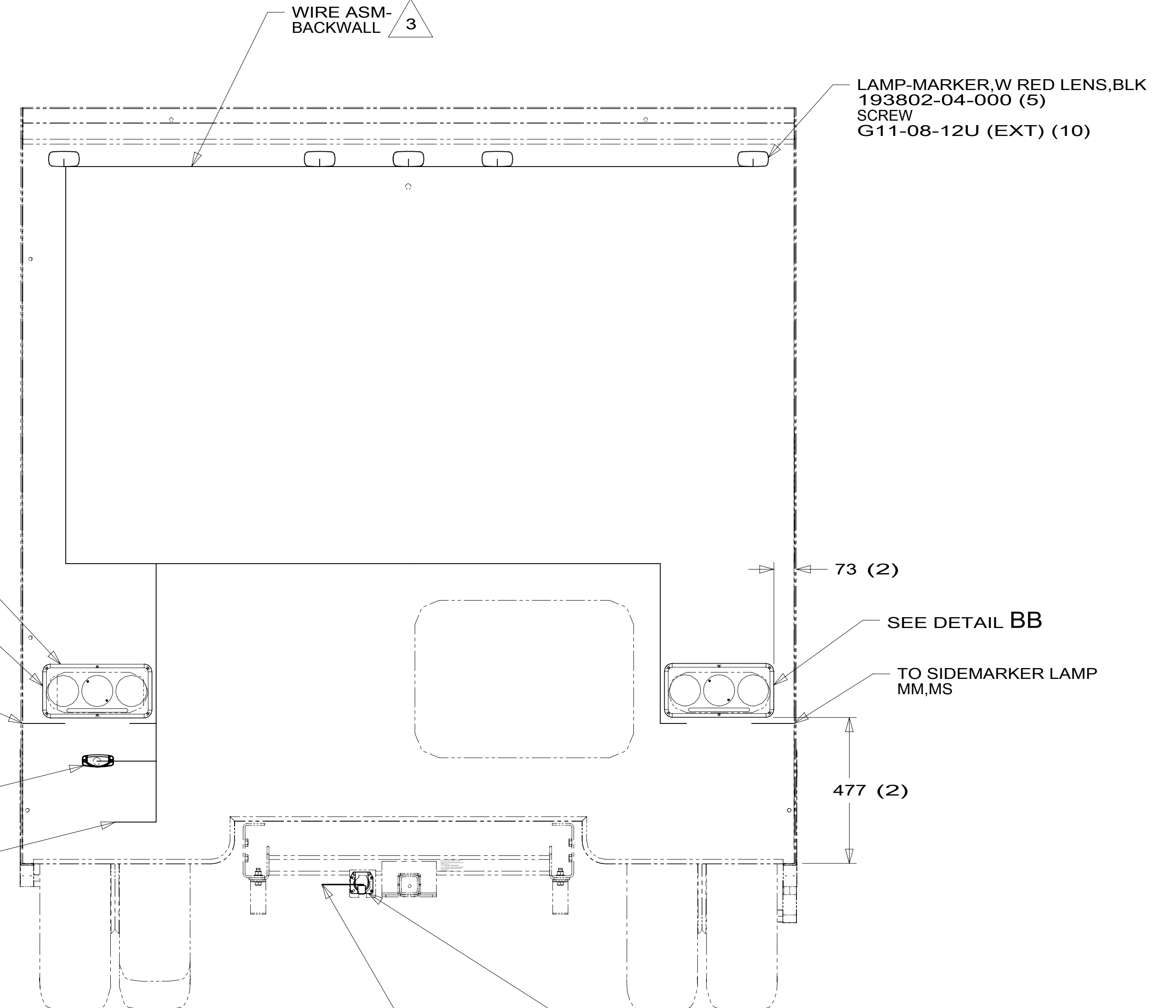
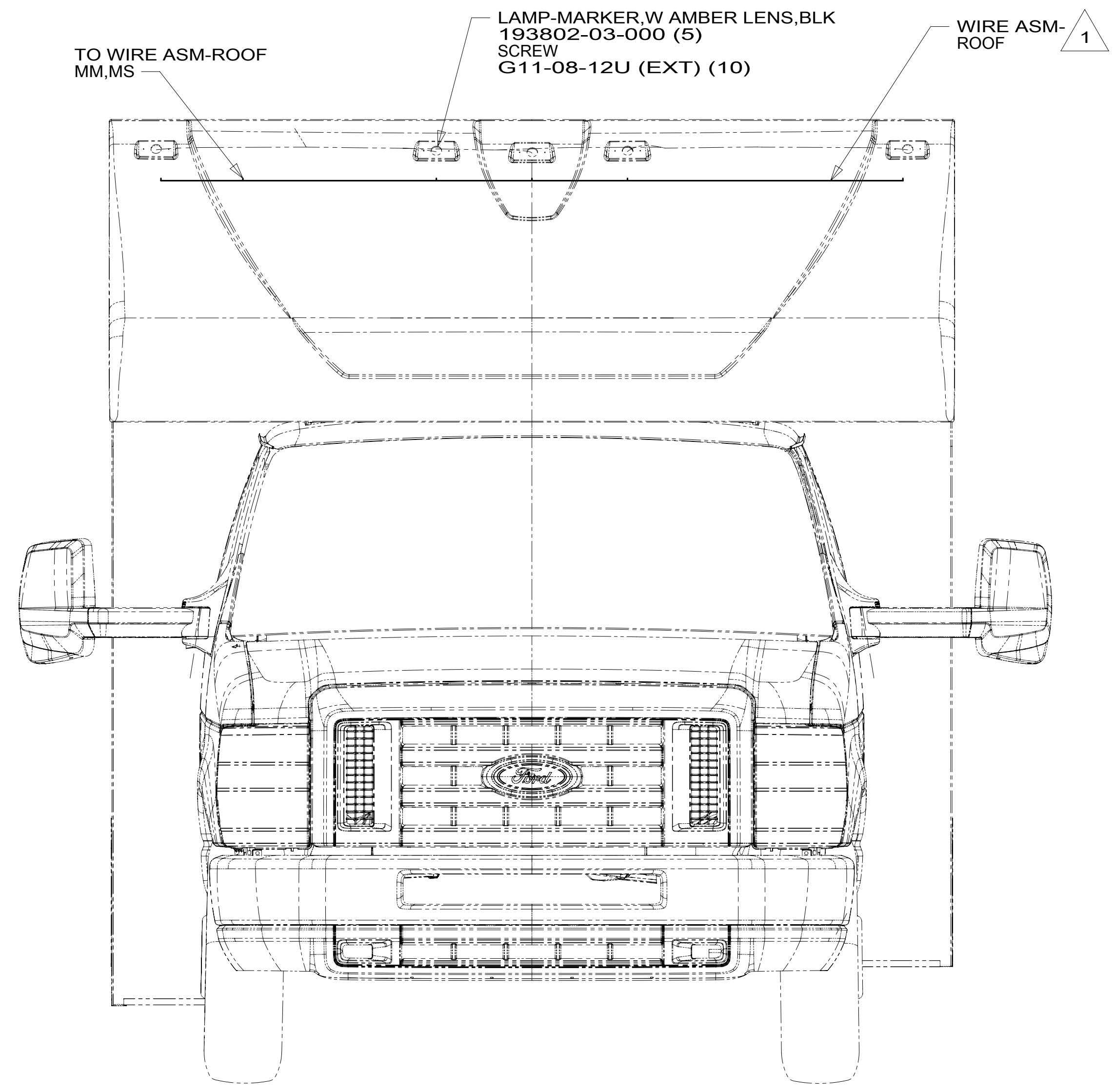

- NOTES:
- 5 APPLY SILICONE ACROSS TOP AND DOWN SIDES WITH FEATURE 64 TRIM GASKET AS NECESSARY.
 - 4 TAIL LAMP MUST BE INSTALLED WITH WIRES DOWN.
 - 3 LOCATED IN BACKWALL ASSEMBLY.
 - 2 SECURE WIRE BELOW COACH WITH CLAMP 10495-01-000 AND SCREW G67-10-12B.
 - 1 LOCATED IN ROOF ASSEMBLY FRONT.

FOR ELECTRICAL TORQUE SPECIFICATIONS SEE DWG NO. 128783-01-000

FOR ELECTRICAL CALLOUTS SEE DWG NO. 121339-01-000

- 244 TRAILER HITCH-7500# DRAW BAR
- 644 GREAT ALASKAN RENTAL PACKAGE
- 240 TRAILER HITCH
- 265 CODES/STANDARDS-CSA/CMVSS
- 1B1 CODES/STANDARDS USA

DESCRIPTION:		1B1 265
WIRING INSTL-EXTERIOR LAMPS		
SHEET:	ITEM/PART NO.:	REV
2 OF 2	000026418 / 31563401000	