

- 12. U-LOCKS TO BE INSTALLED BEFORE THE FRAME ASM IS BOLTED DOWN TO THE CHASSIS AND BEFORE THE SEAL PLANES ARE INSTALLED.
- 11. SEE WIRING INSTL-BODY FOR ELECTRICAL CONNECTION.
- 10. PREP THE SURFACE PER MANUFACTURERS INSTRUCTIONS BEFORE APPLYING THE HEATING PAD.
 - 9. SEE DRAWING 061607 FOR INSTALLATION OF GROMMETS.
- 8. SECURE DRAINAGE PIPES TO CABINET USING WIRE TIE 108046-02-000, AND SCREW 000G67-10-12U AT INTERVALS OF NOT OF NOT MORE THAN 4 FEET APART.
- 7. SECURE VENT PIPE TO FLOOR WITH CLAMP 062401-02-000 (2), SCREW 000G67-10-12U (2), BRACKET 136878-01-CHT (2).
- 6. VENT PIPE MUST PROJECT 51 MIN AND 64 MAX ABOVE ROOF FOR PROPER FIT AND FUNCTION. ADD S-1 (116666-01-CHT SEAL-VENT PIPE) AROUND PIPE ON ROOF BEFORE VENT CAP IS INSTALLED.
- 5. SEAL AROUND SHOWER WITH SILICONE.
- 4. USE SMOOTH PLUMBERS PUTTY 167459-01-000 TO SEAL STRAINER (0.2 PER STRAINER).
- 3. ALL PIPE AND FITTINGS TO BE ASSEMBLED WITH SOLVENT 004020-01-000 (USA), 004020-02-000 (CAN)
- 2. SLOPE OF TRAP ARM MUST BE 6 PER 305 mm.
- 1. SLOPE OF HORIZONTAL PIPING TO BE MINIMUM OF 3 PER 305 mm.

- 23T DRAINAGE SYSTEM-HEATED
- 265 CODES/STANDARDS-CSA/CMVSS
- 1B1 CODES/STANDARDS USA

WINNEBAGO
COPYRIGHT 2016 WINNEBAGO INDUSTRIES, INC.

DSNR:		ALL DIMENSIONS ARE IN MILLIMETERS	
DIFTR:			
UNSPECIFIED TOLERANCES:		MATERIAL:	
WHOLE DIM (X)	3		
ONE-PLACE (X.X)	1.5		
TWO-PLACE (X.XX)	0.50		
ANGLE	1°		
REFER TO ES0018 FOR FASTENER TIGHTENING GUIDELINES		WEIGHT: (LBS)	FIRST USED: (REF)
			17 H25P
DESCRIPTION:			
DRAINAGE SYSTEM INSTL			
SHEET:	ITEM/PART NO.:	REV	
1 OF 4	000025942 / 31545501000		

X-X
FOR DRAINAGE CALLOUTS SEE DWG NO. 303370-01-000

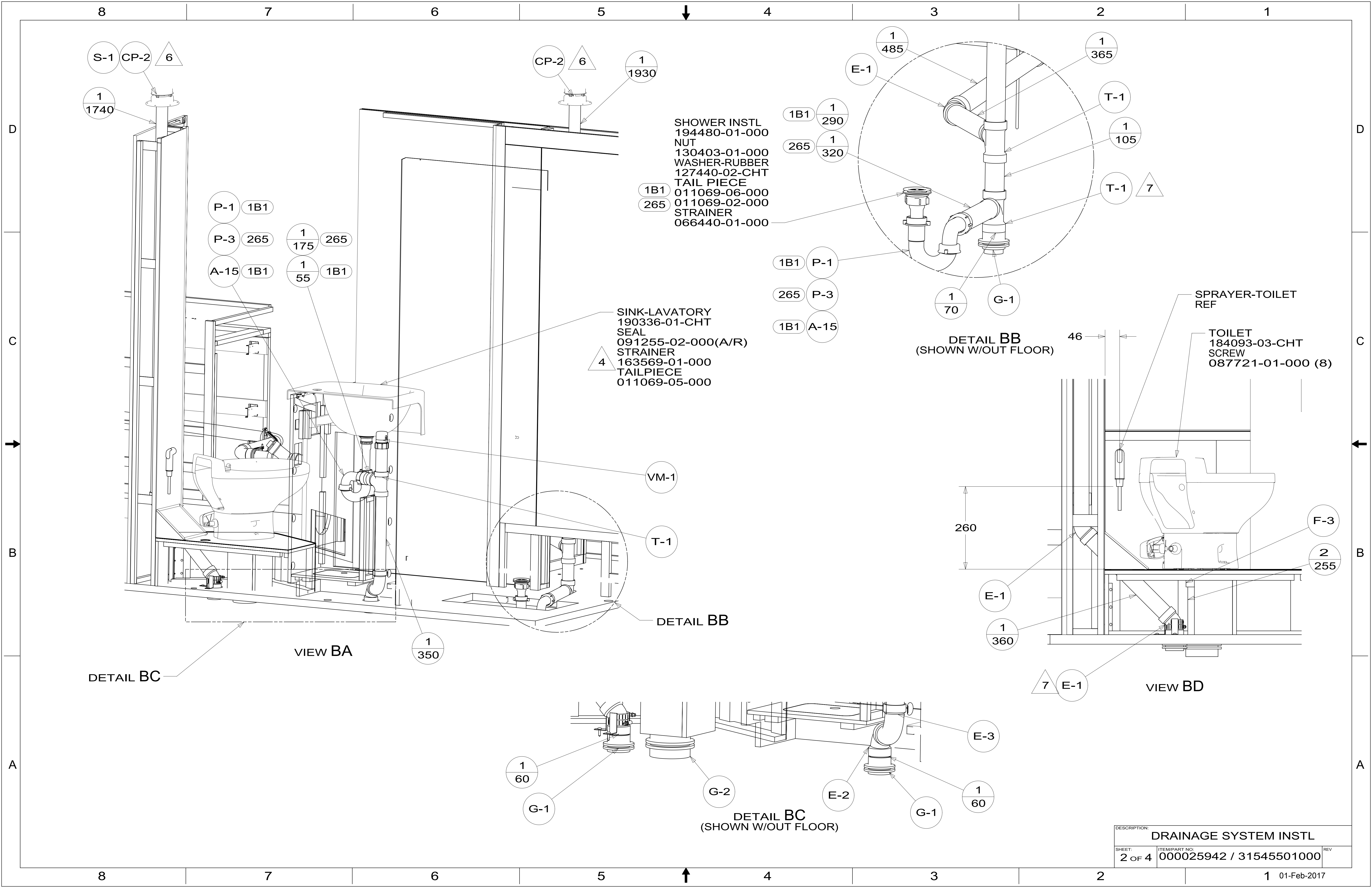

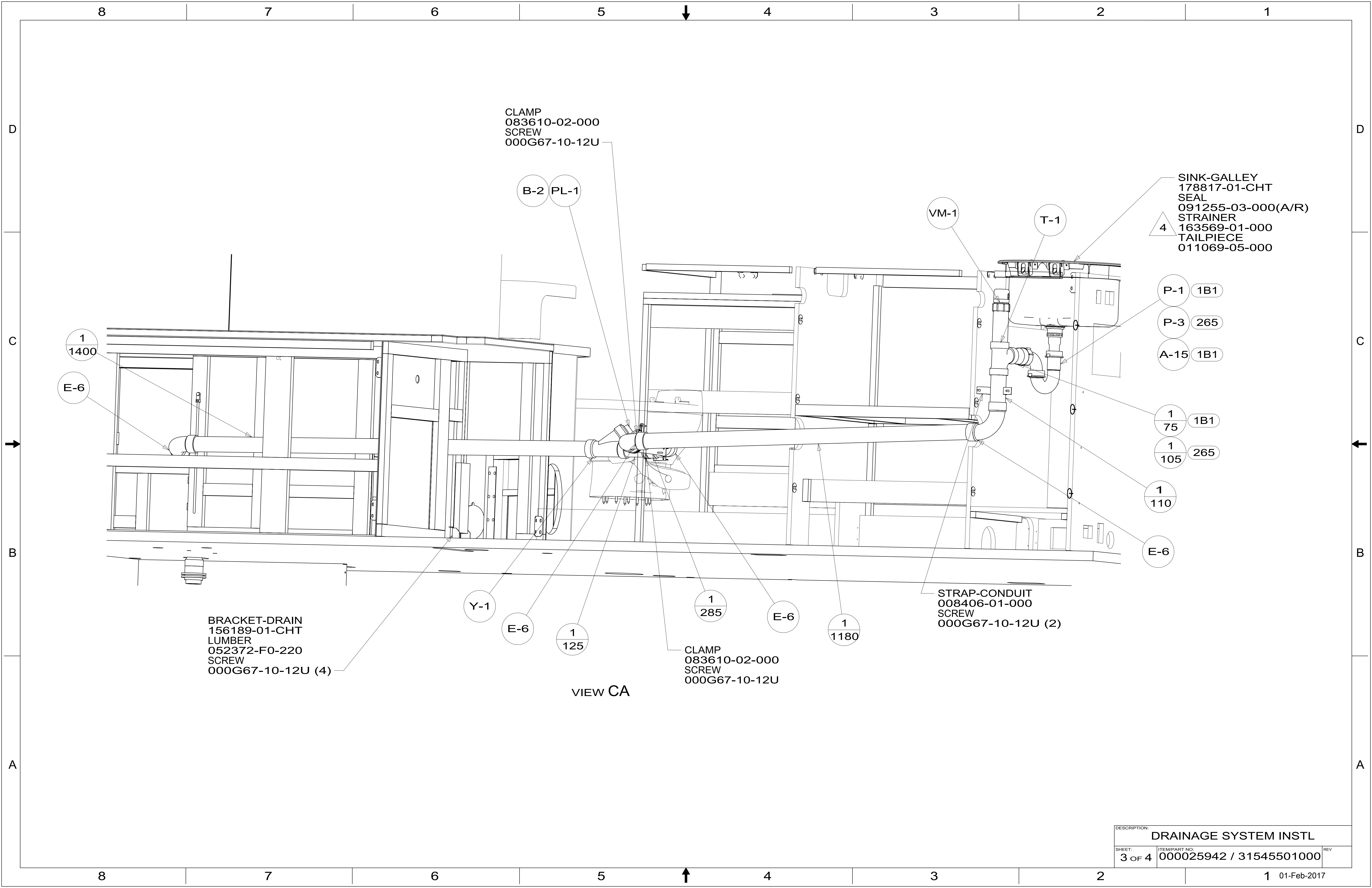

CLAMP
083610-02-000
SCREW
000G67-10-12U

B-2 PL-1

SINK-GALLEY
178817-01-CHT
SEAL
091255-03-000(A/R)
STRAINER
163569-01-000
TAILPIECE
011069-05-000

1
1400

E-6

P-1 1B1

P-3 265

A-15 1B1

1
75 1B1

1
105 265

1
110

E-6

VM-1

T-1

Y-1

E-6

1
125

1
285

E-6

1
1180

STRAP-CONDUIT
008406-01-000
SCREW
000G67-10-12U (2)

BRACKET-DRAIN
156189-01-CHT
LUMBER
052372-F0-220
SCREW
000G67-10-12U (4)

CLAMP
083610-02-000
SCREW
000G67-10-12U

VIEW CA

DESCRIPTION: DRAINAGE SYSTEM INSTL		
SHEET: 3 OF 4	ITEM/PART NO: 000025942 / 31545501000	REV
		1 01-Feb-2017

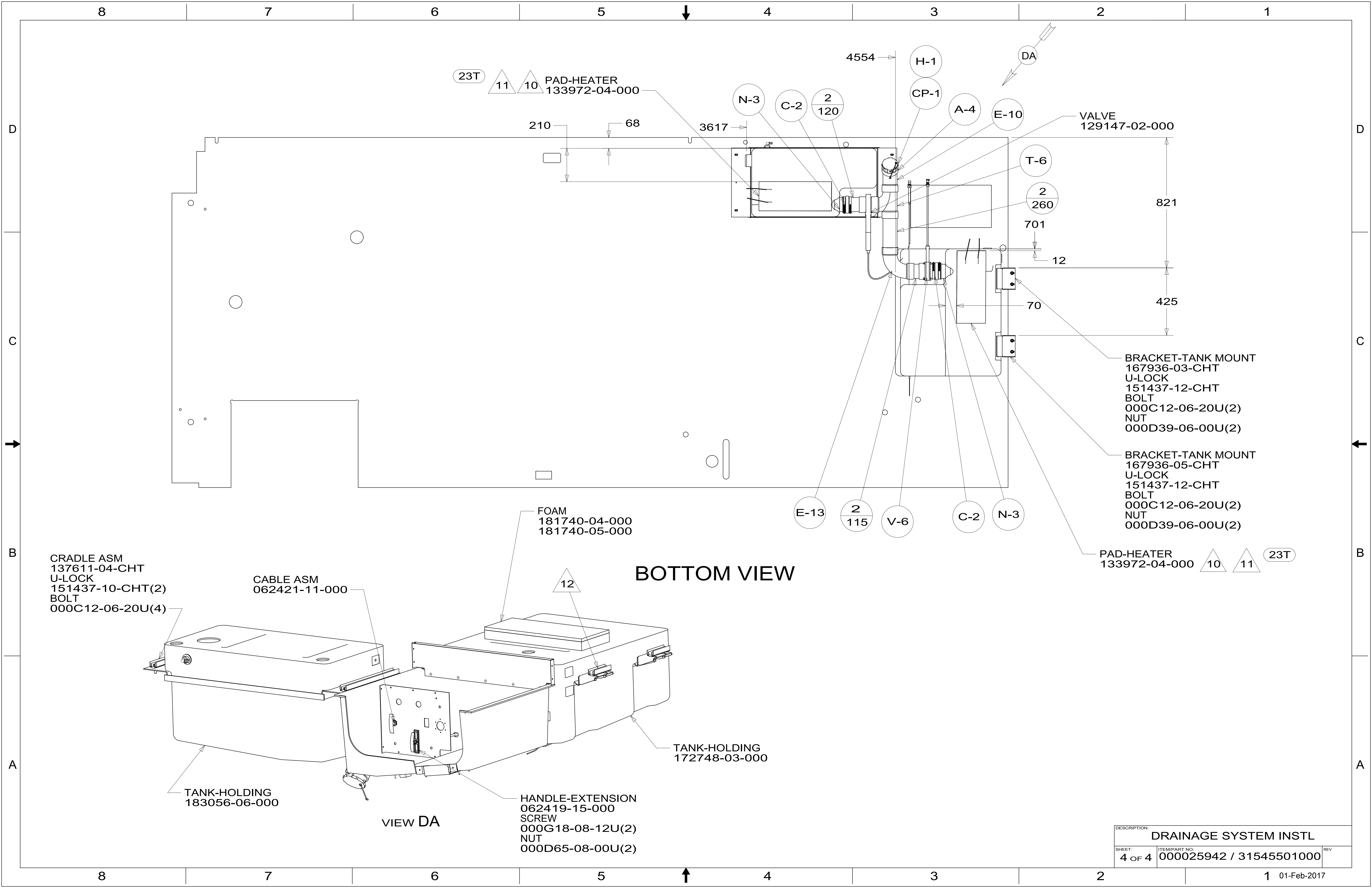

23T 11 10 PAD-HEATER
133972-04-000

210

68

3617

4554

H-1

CP-1

A-4

E-10

VALVE
129147-02-000

T-6

2
260

821

701

12

425

70

BRACKET-TANK MOUNT
167936-03-CHT
U-LOCK
151437-12-CHT
BOLT
000C12-06-20U(2)
NUT
000D39-06-00U(2)

BRACKET-TANK MOUNT
167936-05-CHT
U-LOCK
151437-12-CHT
BOLT
000C12-06-20U(2)
NUT
000D39-06-00U(2)

PAD-HEATER
133972-04-000 10 11 23T

FOAM
181740-04-000
181740-05-000

12

BOTTOM VIEW

CRADLE ASM
137611-04-CHT
U-LOCK
151437-10-CHT(2)
BOLT
000C12-06-20U(4)

CABLE ASM
062421-11-000

TANK-HOLDING
183056-06-000

VIEW DA

HANDLE-EXTENSION
062419-15-000
SCREW
000G18-08-12U(2)
NUT
000D65-08-00U(2)

TANK-HOLDING
172748-03-000

DESCRIPTION: DRAINAGE SYSTEM INSTL		
SHEET: 4 OF 4	ITEM/PART NO: 000025942 / 31545501000	REV