

8 7 6 5 4 3 2 1

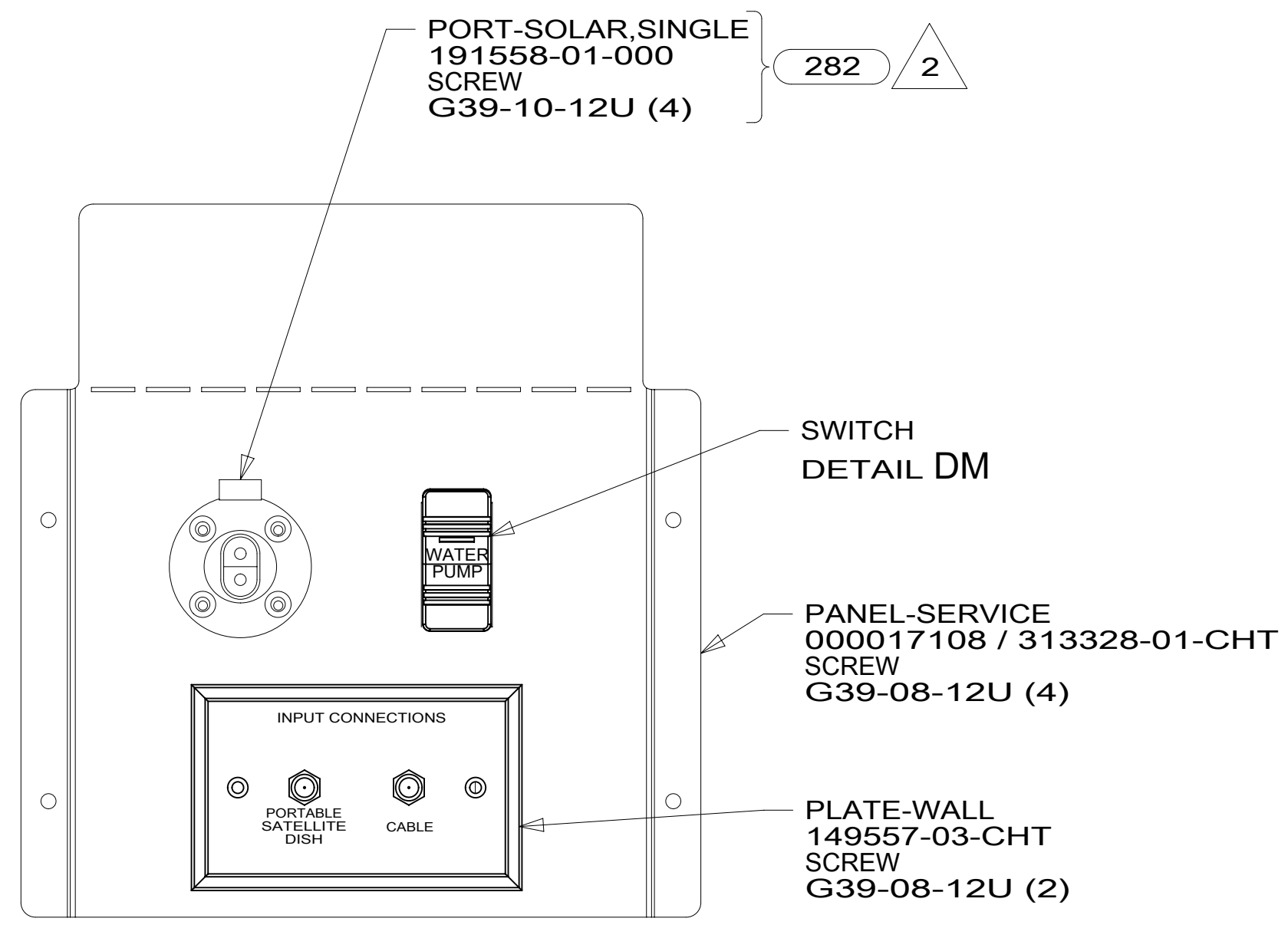

VIEW AA

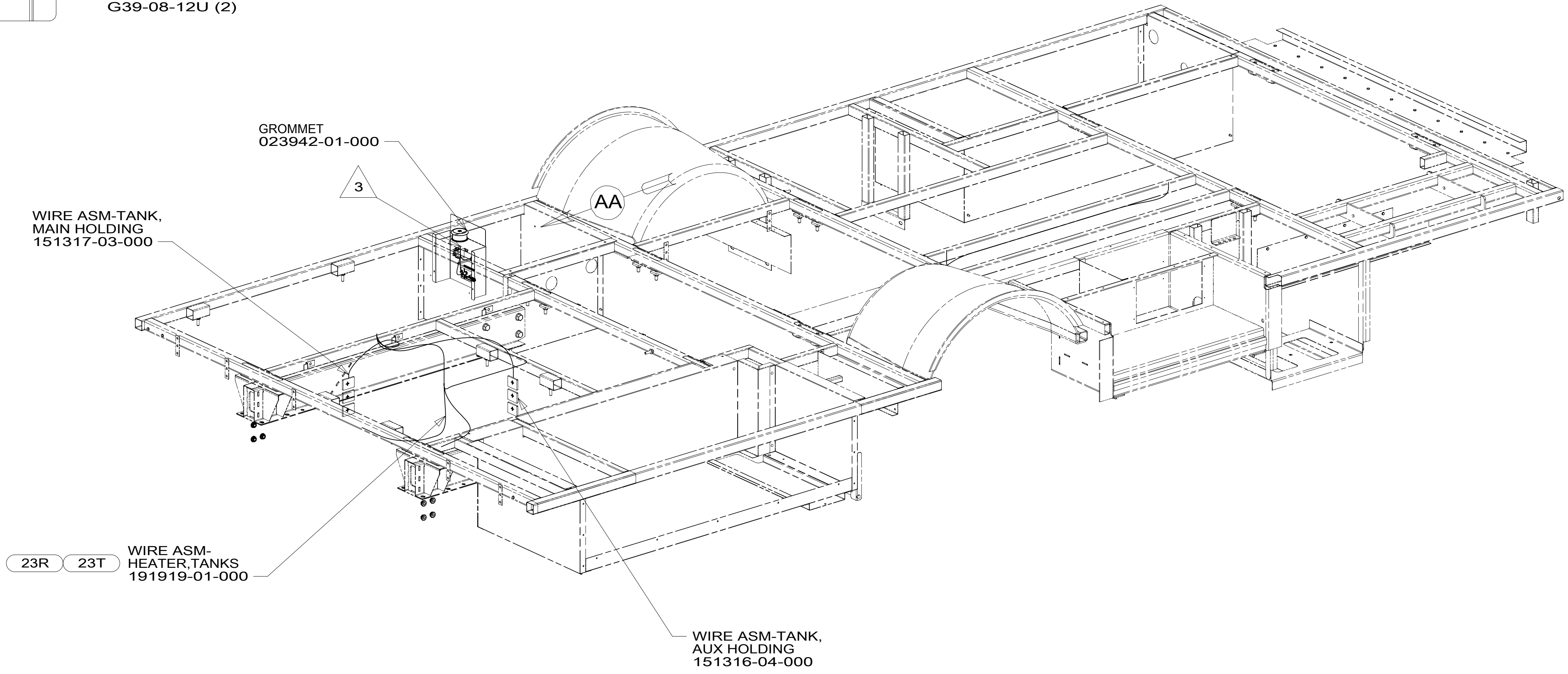

- 3 WIRE PASSES THROUGH FLOOR IN THIS AREA.
- 2 SPLICE YELLOW TO RED AND WHITE TO BLACK.

1. AT MINIMUM ALL WIRES TO BE SUPPORTED AND SECURED PER CODE REQUIREMENTS. USE CLAMP 10495 OR 10497 OR WIRE TIE 8343 OR 108046 AND SCREW G67-XX-XXX OR G56-XX-XXX AS APPROPRIATE FOR INSTALLATION.

NOTES:

- 282 SOLAR PANEL - 100 WATT
- 23T DRAINAGE SYSTEM-HEATED
- 23R DRAINAGE SYSTEM/HEAT-PREWIRED
- 265 CODES/STANDARDS-CSA/CMVSS
- 1B1 CODES/STANDARDS USA

1B1 265



DSNR:	ALL DIMENSIONS ARE IN MILLIMETERS	
DIFFR:	MATERIAL:	
UNSPECIFIED TOLERANCES:	WEIGHT: (LBS)	FIRST USED:
WHOLE DIM (X) : 3		17 423T
ONE-PLACE (X.X) : 1.5		
TWO-PLACE (X.XX) : 0.50		
ANGLE : 1°		

REFER TO ES0018 FOR FASTENER TIGHTENING GUIDELINES

**WIRING INSTL-BODY, 12V**

SHEET: 1 OF 5	ITEM/PART NO: 000025559 / 31532701000	REV:
---------------	---------------------------------------	------

FOR ELECTRICAL TORQUE SPECIFICATIONS SEE DWG NO. 128783-01-000

FOR ELECTRICAL CALLOUTS SEE DWG NO. 121339-01-000

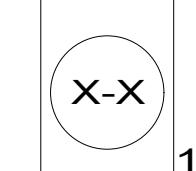

8 7 6 5 4 3 2 1

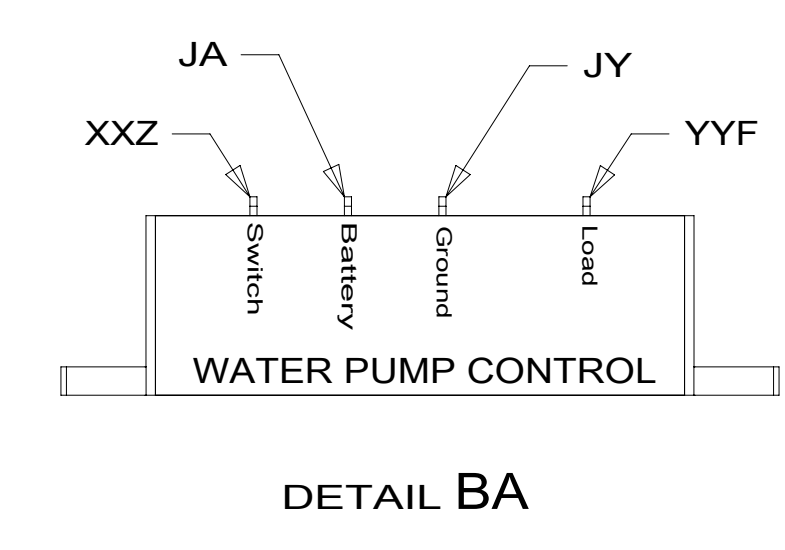
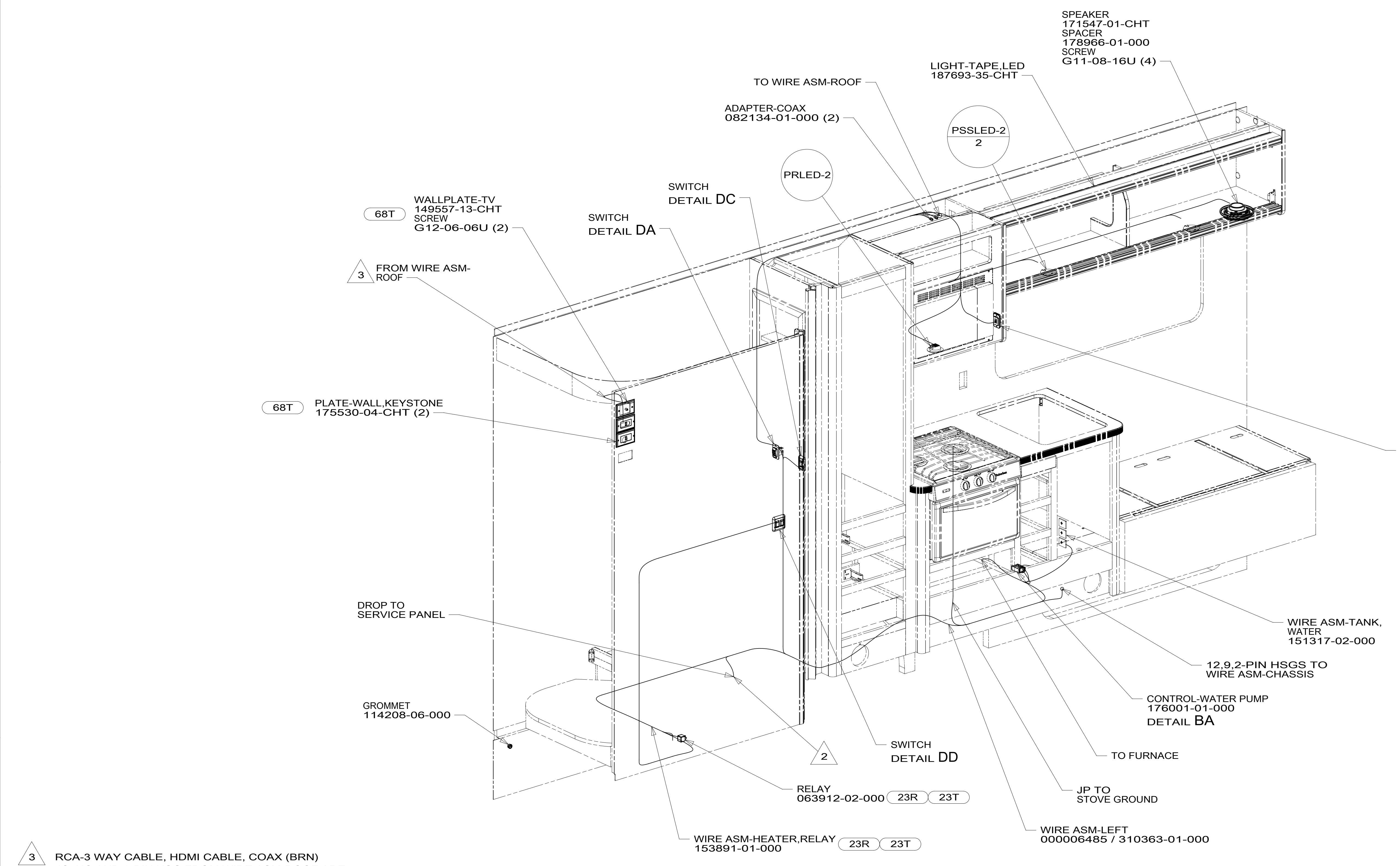

3 RCA-3 WAY CABLE, HDMI CABLE, COAX (BRN) JC, NC AND 2-PIN HSG FROM WIRE ASM-ROOF ARE ROUTED OUT END OF ROOF, IN BACKWALL CAP THEN THROUGH BACKWALL TO WALL PLATES.

2 WIRE PASSES THROUGH FLOOR IN THIS AREA.

1. AT MINIMUM ALL WIRES TO BE SUPPORTED AND SECURED PER CODE REQUIREMENTS. USE CLAMP 10495 OR 10497 OR WIRE TIE 8343 OR 108046 AND SCREW G67-XX-XXX OR G56-XX-XXX AS APPROPRIATE FOR INSTALLATION.

NOTES:

- 23T DRAINAGE SYSTEM-HEATED
- 23R DRAINAGE SYSTEM/HEAT-PREWIRED
- 68T TV - BEDROOM WITHOUT
- 265 CODES/STANDARDS-CSA/CMVSS
- 1B1 CODES/STANDARDS USA

FOR ELECTRICAL TORQUE SPECIFICATIONS SEE DWG NO. 128783-01-000

FOR ELECTRICAL CALLOUTS SEE DWG NO. 121339-01-000

1B1	265
DESCRIPTION: <b>WIRING INSTL-BODY, 12V</b>	
SHEET: 2 OF 5	ITEM/PART NO: 000025559 / 31532701000
REV 04-Jan-2017	

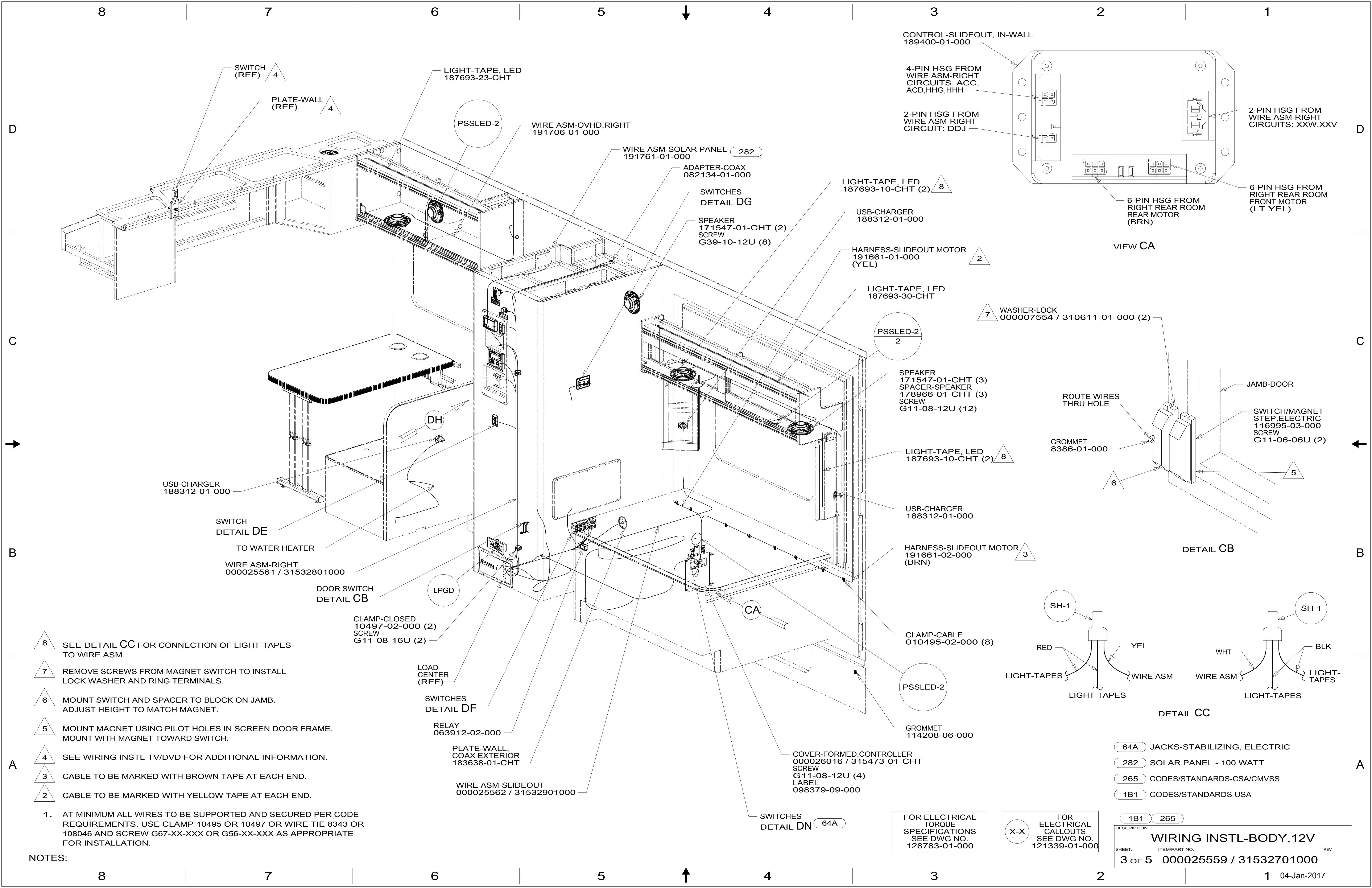

- 8 SEE DETAIL CC FOR CONNECTION OF LIGHT-TAPES TO WIRE ASM.
- 7 REMOVE SCREWS FROM MAGNET SWITCH TO INSTALL LOCK WASHER AND RING TERMINALS.
- 6 MOUNT SWITCH AND SPACER TO BLOCK ON JAMB. ADJUST HEIGHT TO MATCH MAGNET.
- 5 MOUNT MAGNET USING PILOT HOLES IN SCREEN DOOR FRAME. MOUNT WITH MAGNET TOWARD SWITCH.
- 4 SEE WIRING INSTL-TV/DVD FOR ADDITIONAL INFORMATION.
- 3 CABLE TO BE MARKED WITH BROWN TAPE AT EACH END.
- 2 CABLE TO BE MARKED WITH YELLOW TAPE AT EACH END.

1. AT MINIMUM ALL WIRES TO BE SUPPORTED AND SECURED PER CODE REQUIREMENTS. USE CLAMP 10495 OR 10497 OR WIRE TIE 8343 OR 108046 AND SCREW G67-XX-XXX OR G56-XX-XXX AS APPROPRIATE FOR INSTALLATION.

NOTES:

FOR ELECTRICAL TORQUE SPECIFICATIONS SEE DWG NO. 128783-01-000

FOR ELECTRICAL CALLOUTS SEE DWG NO. 121339-01-000

- 64A JACKS-STABILIZING, ELECTRIC
- 282 SOLAR PANEL - 100 WATT
- 265 CODES/STANDARDS-CSA/CMVSS
- 1B1 CODES/STANDARDS USA

DESCRIPTION: <b>WIRING INSTL-BODY, 12V</b>		
SHEET: 3 OF 5	ITEM/PART NO: 000025559 / 31532701000	REV

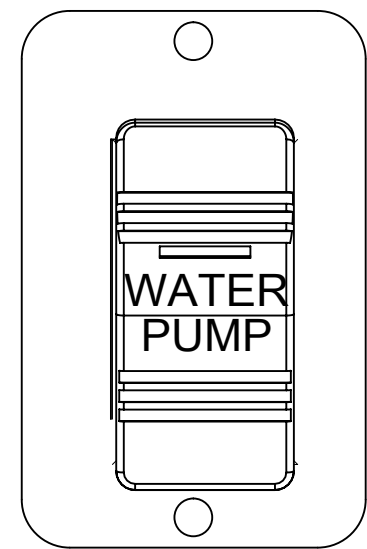

SWITCH-ROCKER  
108357-21-000  
ACTUATOR-SWITCH  
108356-23-CHT  
PLATE-SWITCH  
144363-02-CHT  
SCREW  
G11-06-10U (2)

DETAIL DA

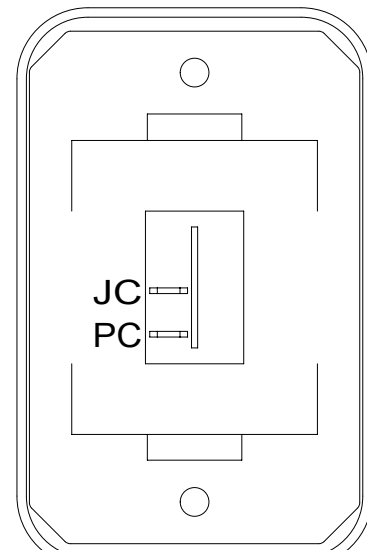

SWITCH-ROCKER  
135740-01-CHT  
SWITCH-BASE  
135741-01-CHT  
SWITCH-BEZEL  
135742-01-CHT  
SCREW  
G11-08-08U (2)

DETAIL DB

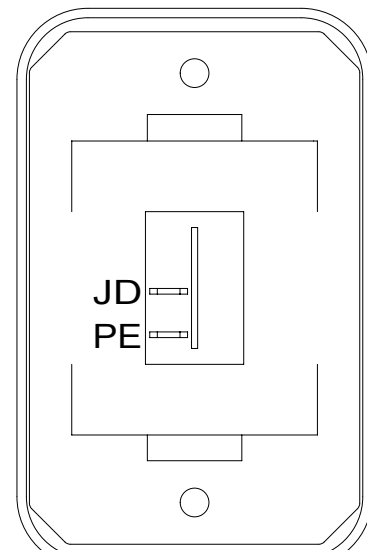

SWITCH-ROCKER  
135740-01-CHT  
SWITCH-BASE  
135741-01-CHT  
SWITCH-BEZEL  
135742-01-CHT  
SCREW  
G11-08-08U (2)

DETAIL DC

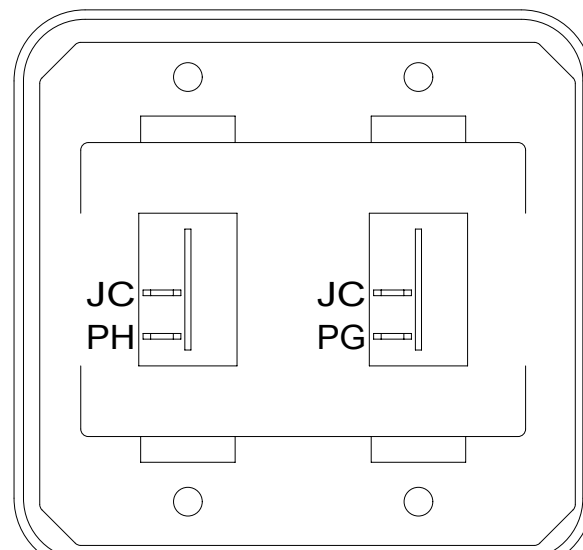

SWITCH-ROCKER  
135740-01-CHT (2)  
SWITCH-BASE  
135741-02-CHT  
SWITCH-BEZEL  
135742-02-CHT  
SCREW  
G11-08-08U (4)

DETAIL DD

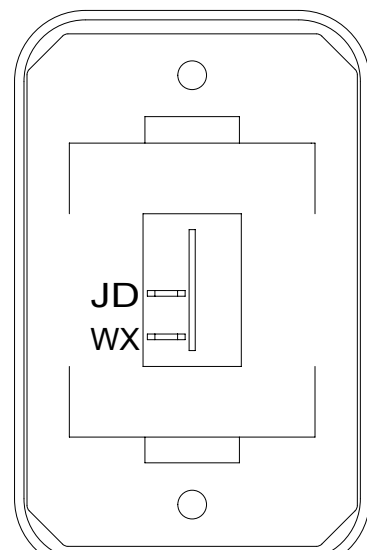

SWITCH-ROCKER  
135740-01-CHT  
SWITCH-BASE  
135741-01-CHT  
SWITCH-BEZEL  
135742-01-CHT  
SCREW  
G11-08-08U (2)

DETAIL DE

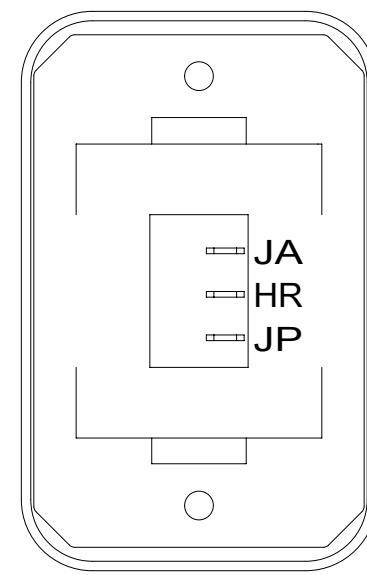

SWITCH-ROCKER  
135740-06-CHT  
SWITCH-BASE  
135741-01-CHT  
SWITCH-BEZEL  
135742-01-CHT  
SCREW  
G11-08-08U (2)

DETAIL DJ

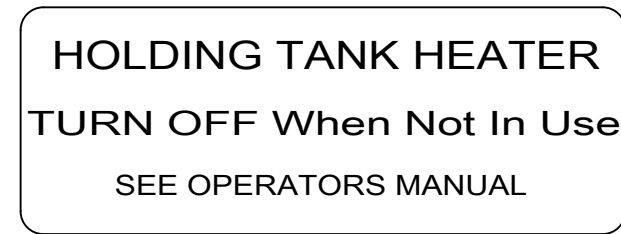

LABEL-SWITCH,  
HTR,HOLDING TK  
134563-01-CHT

DETAIL DJ 23T 23R

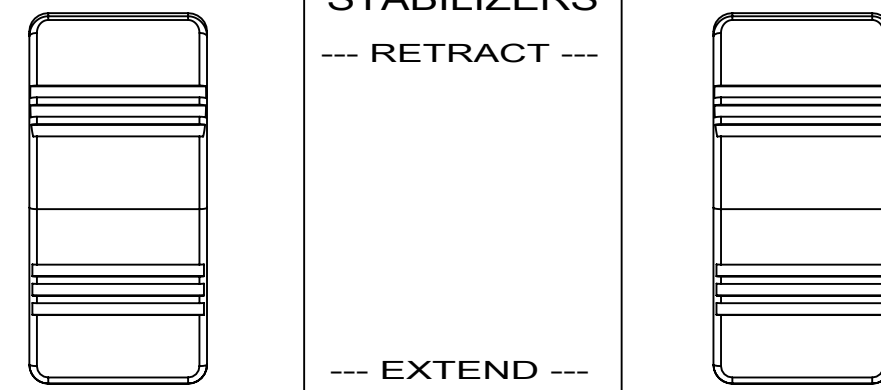

DETAIL DN 64A

SWITCH-ROCKER  
108357-06-000 (2)  
ACTUATOR  
108356-01-000 (2)  
LABEL  
000007799 / 310651-01-CHT

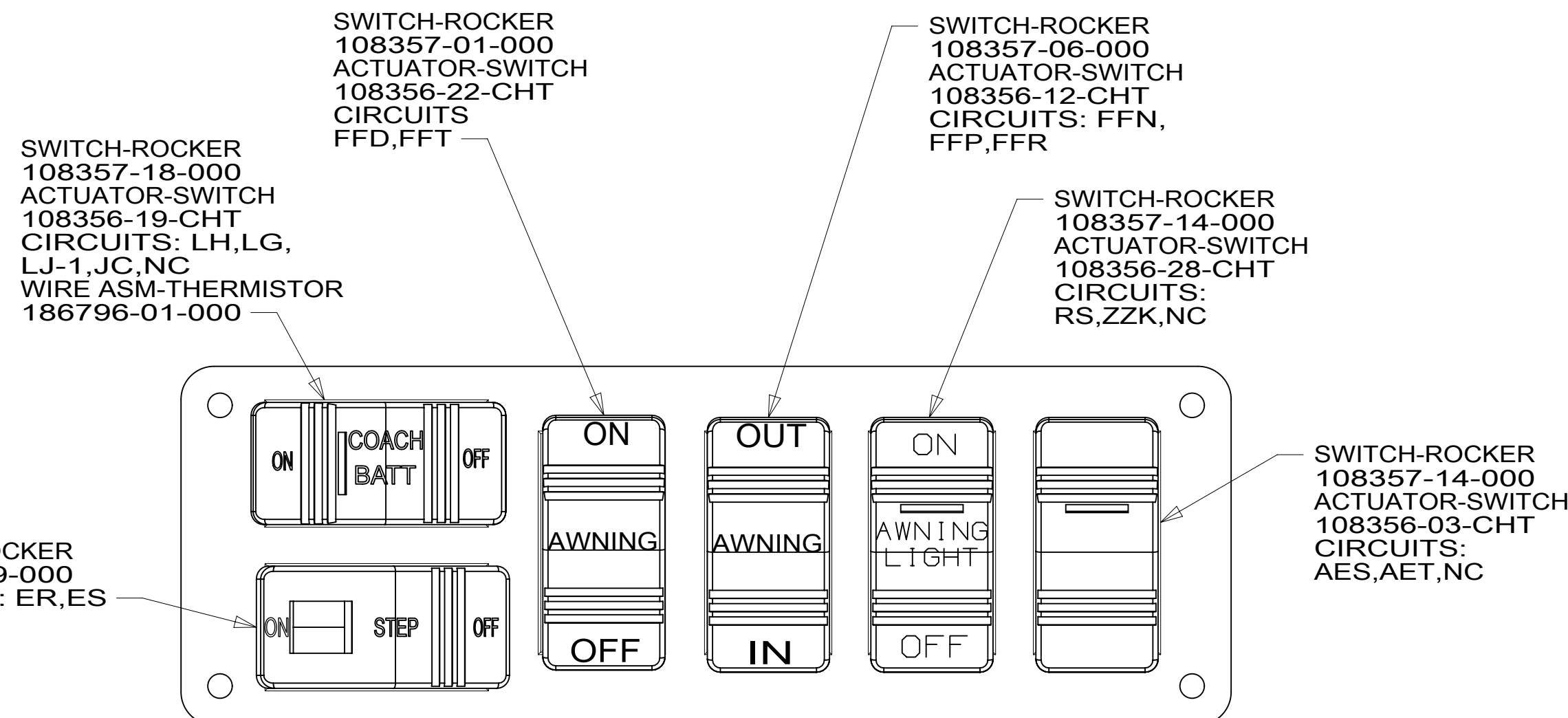

DETAIL DF

SWITCH-ROCKER  
108357-18-000  
ACTUATOR-SWITCH  
108356-19-CHT  
CIRCUITS: LH,LG,  
LJ-1,JC,NC  
WIRE ASM-THERMISTOR  
186796-01-000

SWITCH-ROCKER  
108357-01-000  
ACTUATOR-SWITCH  
108356-22-CHT  
CIRCUITS: FFD,FFT

SWITCH-ROCKER  
108357-06-000  
ACTUATOR-SWITCH  
108356-12-CHT  
CIRCUITS: FFN,  
FFP,FFR

SWITCH-ROCKER  
108357-14-000  
ACTUATOR-SWITCH  
108356-28-CHT  
CIRCUITS:  
RS,ZZK,NC

SWITCH-ROCKER  
108357-14-000  
ACTUATOR-SWITCH  
108356-03-CHT  
CIRCUITS:  
AES,AET,NC

PLATE-SWITCH  
000022055 / 314395-01-CHT  
SCREW  
G11-06-10U (4)

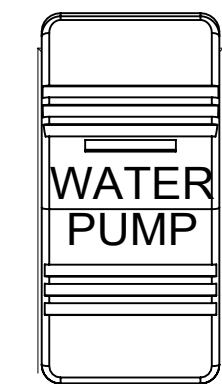

VIEW DM

PANEL-MONITOR,LCD  
175724-01-000  
175724-02-000  
SCREW  
G11-08-08U (4)

SWITCH-PANEL,  
GENERATOR

CONTROL-CHARGE,  
SOLAR 30 AMP  
191278-01-000  
SCREW  
G11-08-08U (2)  
DETAIL DK

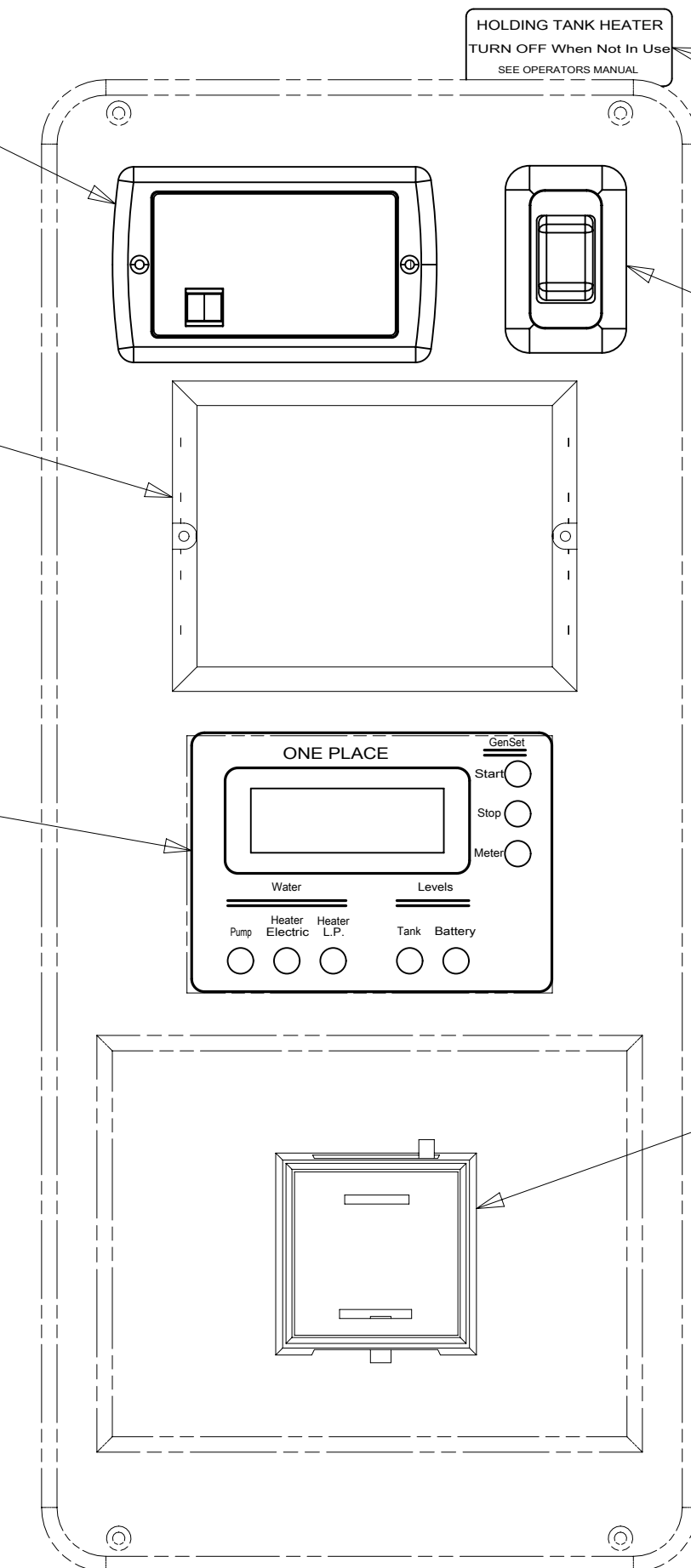

VIEW DH

PLATE-SWITCH  
144363-02-CHT  
SCREW  
G11-08-08U (2)

SWITCH-ROCKER  
108357-18-000  
ACTUATOR-SWITCH  
108356-31-CHT  
CIRCUITS  
HHH,BW,HHG

LABEL-WARNING,  
SLIDEOUT  
116549-02-000

LABEL-SWITCH,  
HTR,HOLDING TK  
(REF)

SWITCH  
DETAIL DJ

THERMOSTAT-FURNACE  
115764-01-CHT  
SCREW  
G11-08-08U (2)

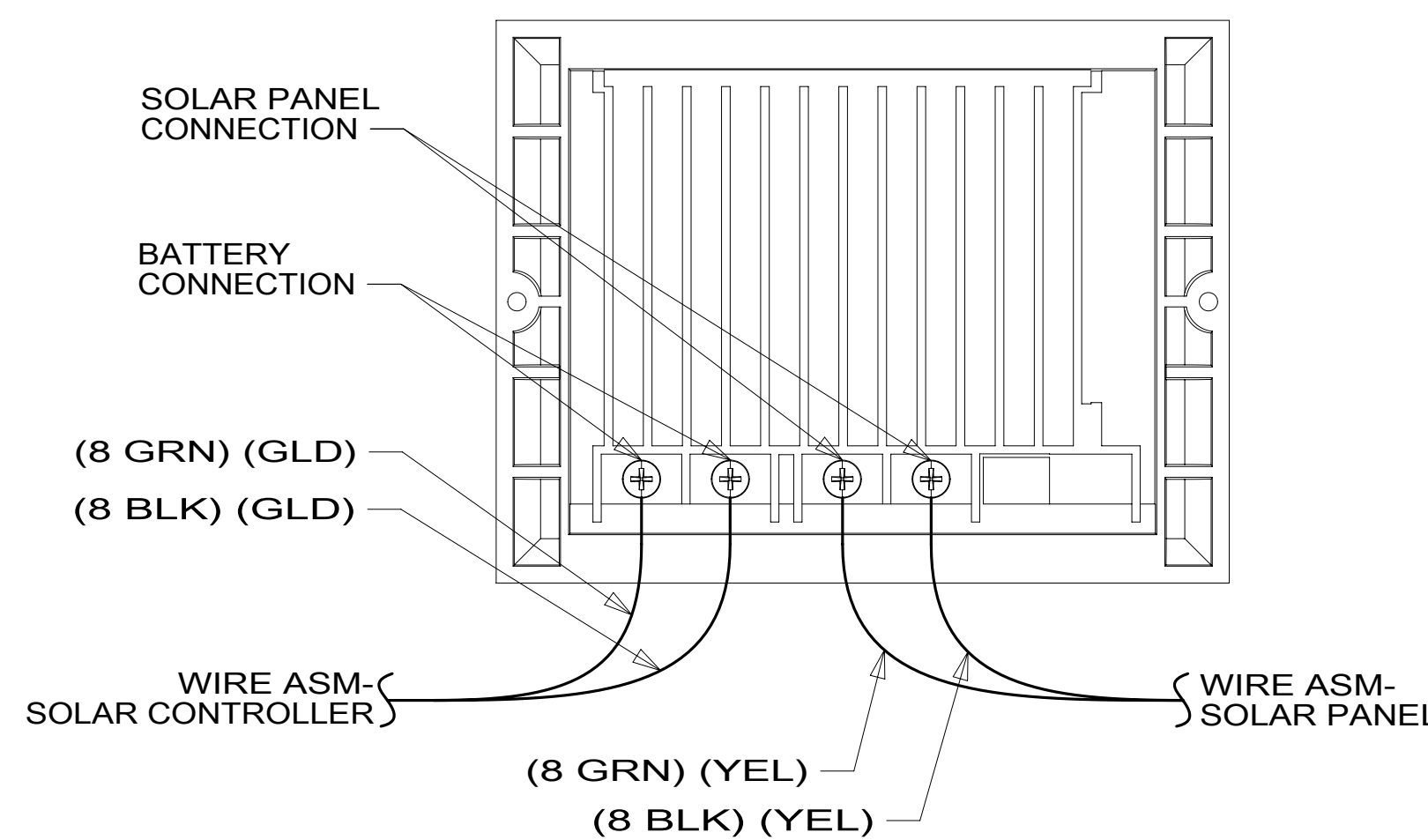

DETAIL DK

FOR ELECTRICAL  
TORQUE  
SPECIFICATIONS  
SEE DWG NO.  
128783-01-000

FOR  
ELECTRICAL  
CALLOUTS  
SEE DWG NO.  
121339-01-000

- 64A JACKS-STABILIZING, ELECTRIC
- 384 GEN 2.5KW ONAN-LP
- 1G8 GEN-2.8KW ONAN GAS
- 1A3 GENERATOR WITHOUT
- 282 SOLAR PANEL - 100 WATT
- 33F GEN-3.2 KW ONAN DIESEL
- 23R DRAINAGE SYSTEM/HEAT-PREWIRE
- 23T DRAINAGE SYSTEM-HEATED
- 265 CODES/STANDARDS-CSA/CMVSS
- 1B1 CODES/STANDARDS USA

1B1 265

DESCRIPTION:  
**WIRING INSTL-BODY, 12V**

SHEET: 4 OF 5 ITEM/PART NO: 000025559 / 31532701000 REV

NOTES:  
1 SUPPLIED WITH GENERATOR.



8 7 6 5 4 3 2 1

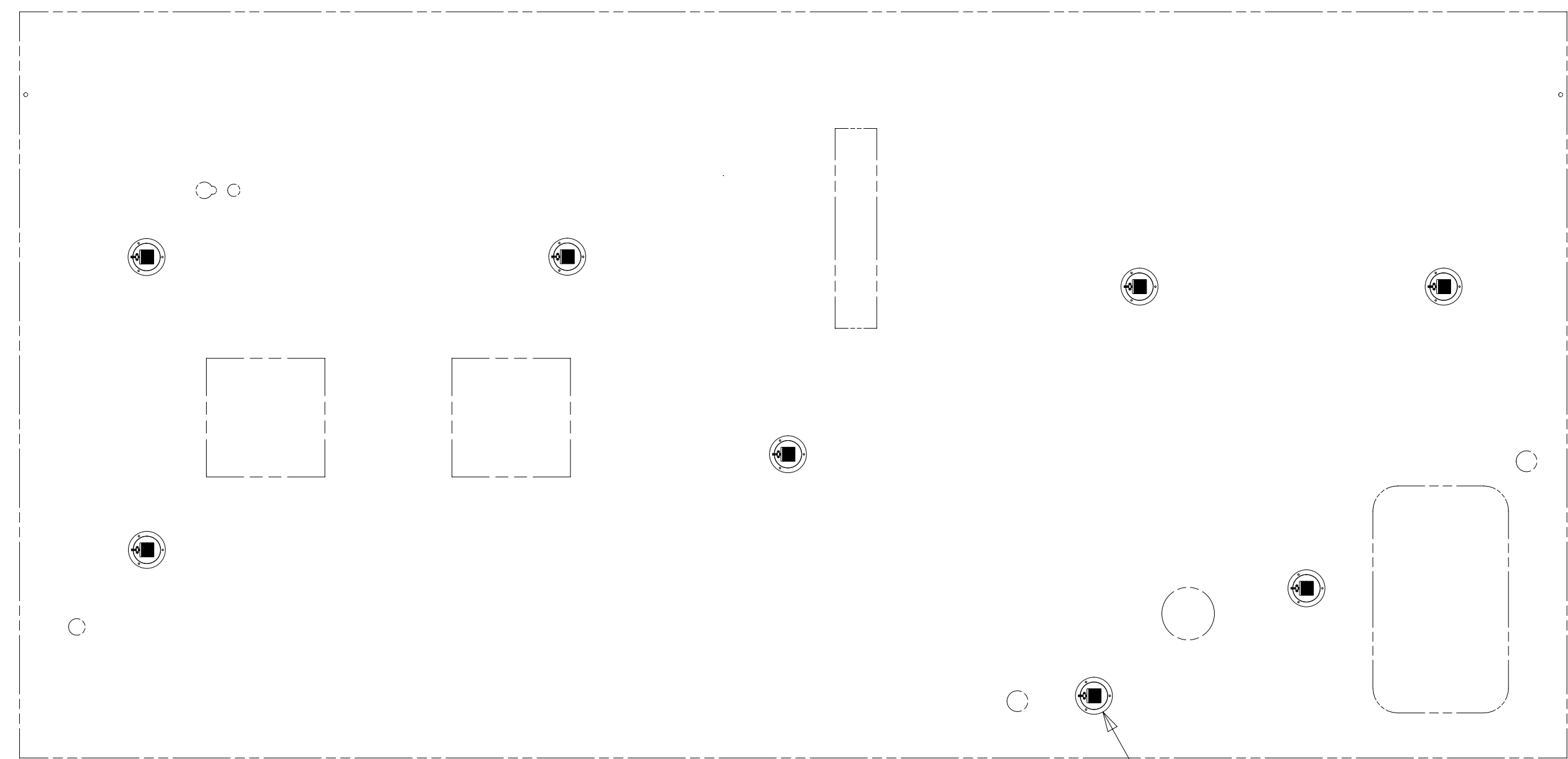

PRLED-4  
8

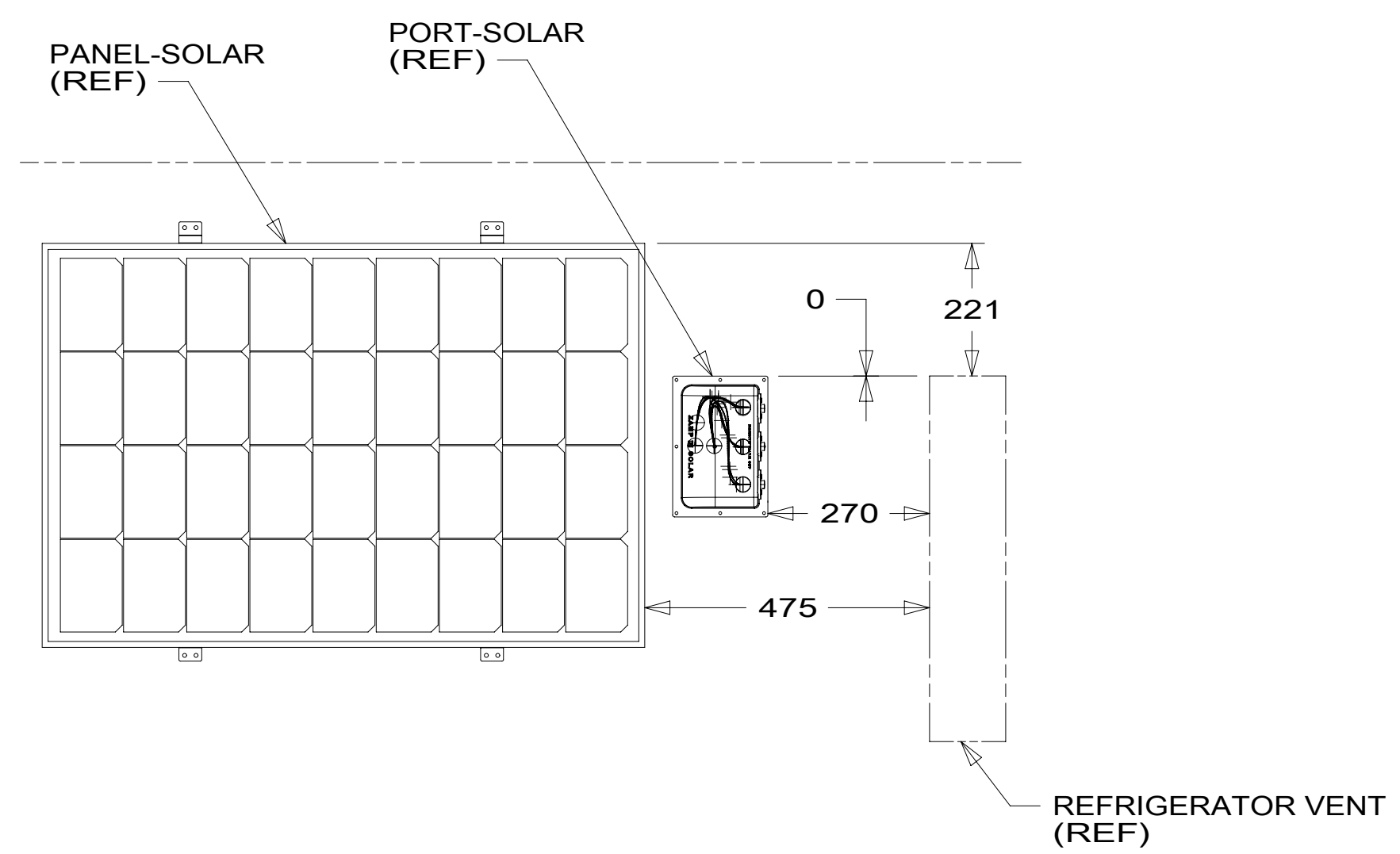

DETAIL EB

PANEL-SOLAR 100 WATT  
191276-01-CHT  
MOUNTING FEET-SOLAR, QTY 4  
000031418 / 316962-01-000  
SCREW  
G39-10-10U (8)

DETAIL EB

PORT-SOLAR,  
3 POSITION  
191277-01-CHT  
DETAIL EC

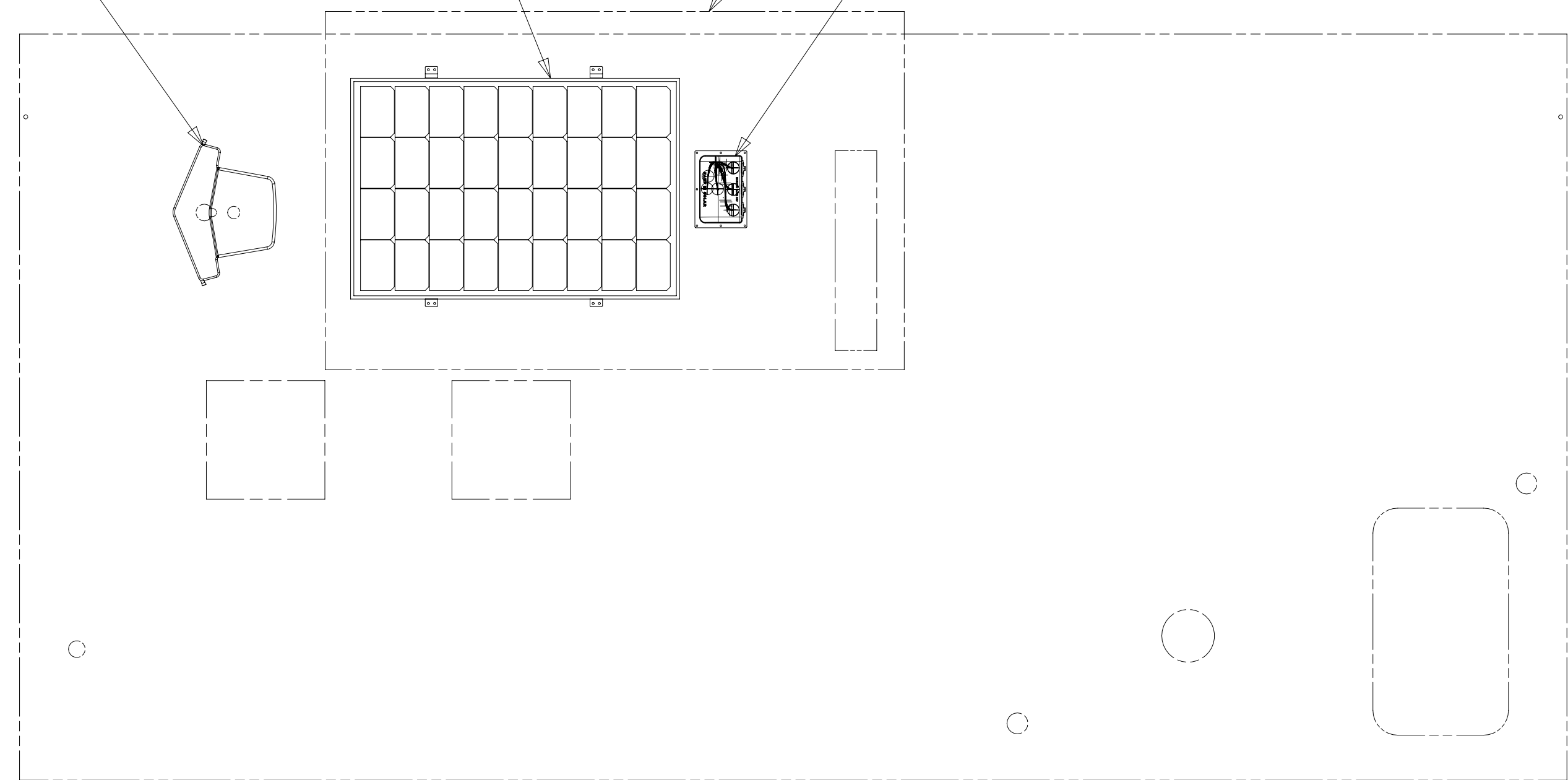

ANT-R  
VIEW EA

ANT-8

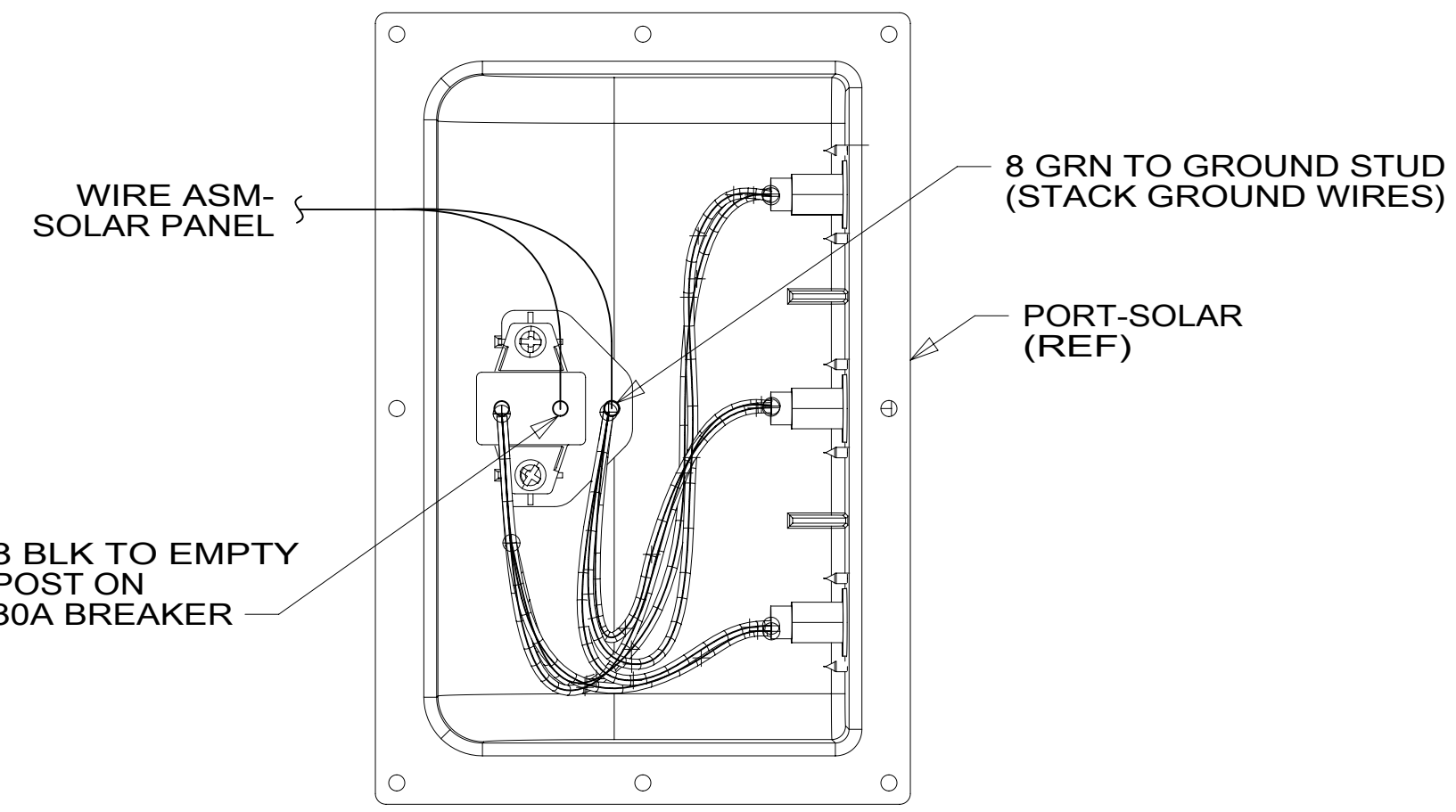

DETAIL EC

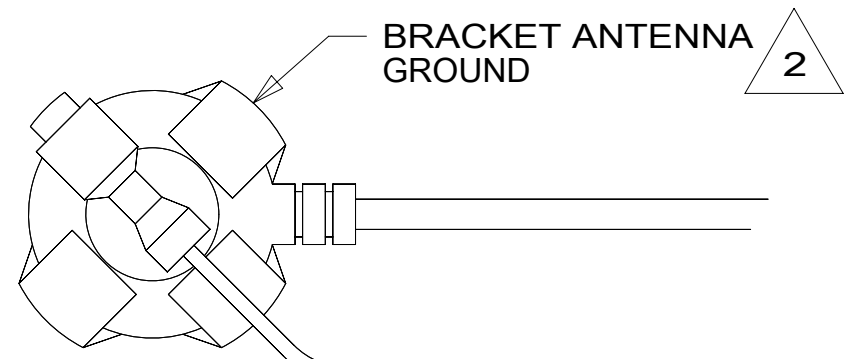

VIEW EA

- NOTES:
- 2 WRAP BRACKET LEGS AROUND ANTENNA BASE.
  - 1 SEE ANTENNA INSTALLATION MANUAL FOR CORRECT INSTALLATION PROCEDURE.

FOR ELECTRICAL TORQUE SPECIFICATIONS SEE DWG NO. 128783-01-000

FOR ELECTRICAL CALLOUTS SEE DWG NO. 121339-01-000

- 282 SOLAR PANEL - 100 WATT
- 265 CODES/STANDARDS-CSA/CMVSS
- 1B1 CODES/STANDARDS USA

DESCRIPTION:	
<b>WIRING INSTL-BODY, 12V</b>	
SHEET:	ITEM/PART NO. REV
5 OF 5	000025559 / 31532701000

8 7 6 5 4 3 2 1 04-Jan-2017