

VIEW AA

HARNESS-SLIDEOUT MOTOR  
191660-01-000

HARNESS-SLIDEOUT MOTOR  
191660-01-000

PANEL-SWITCH  
000028367 / 316237-01-CHT  
SWITCH-ROCKER  
108357-06-000 (2)  
ACTUATOR  
108356-01-CHT (2)  
LABEL-STABILIZER  
000007799 / 310651-01-CHT

PSSLED-2  
SCREW  
G39-08-12U (2)

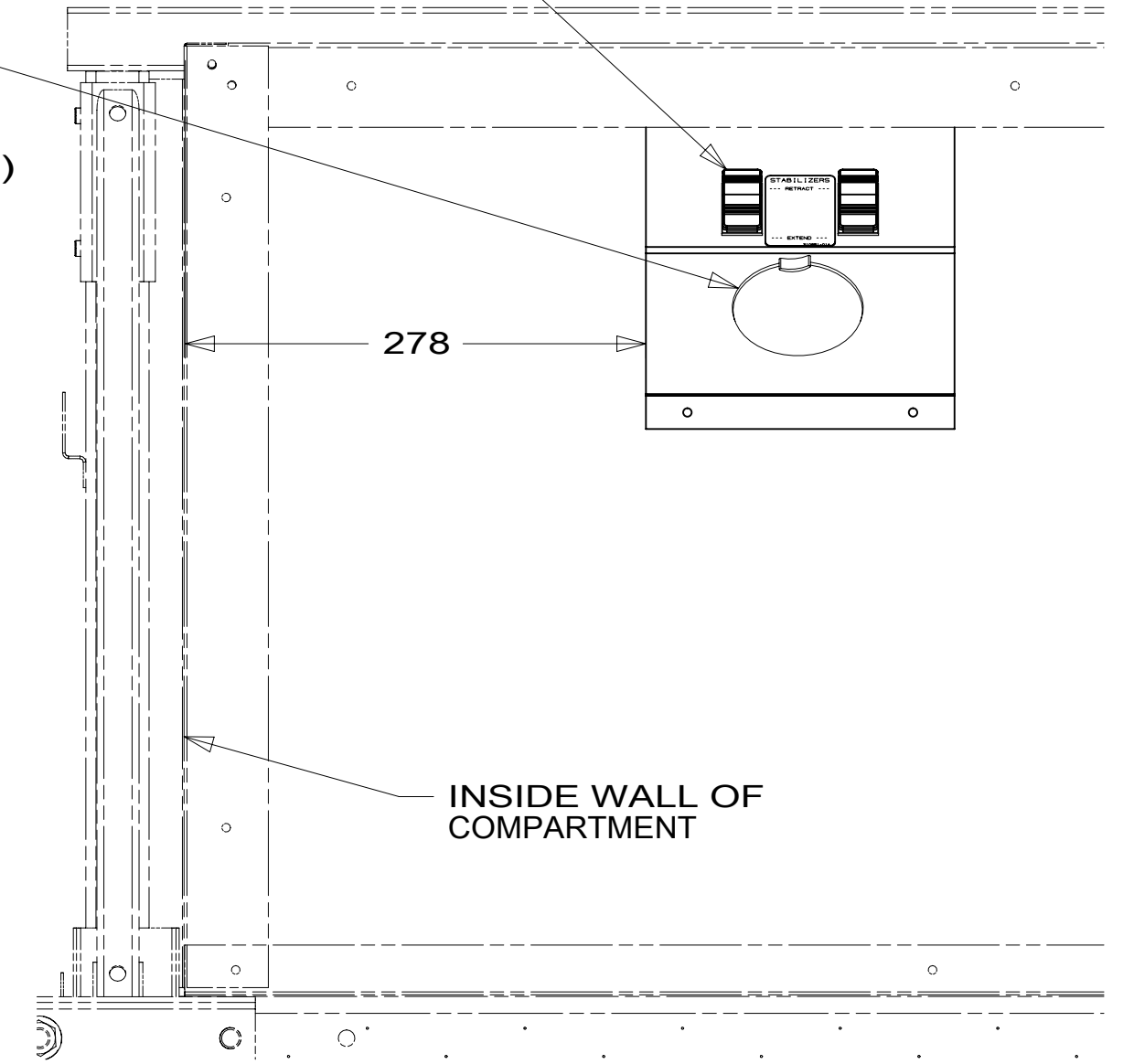

VIEW AB

WIRE ASM-TANK,  
AUX HOLDING  
151316-04-000

GROMMET  
023942-01-000

WIRE ASM-HEATER, TANKS  
191919-01-000

WIRE ASM-TANK,  
MAIN HOLDING  
151317-04-000

GROMMET  
114208-06-000

- 60T JACKS-STABILIZING, ELECT W/O
- 64A JACKS-STABILIZING, ELECTRIC
- 282 SOLAR PANEL - 100 WATT
- 23T DRAINAGE SYSTEM-HEATED
- 23R DRAINAGE SYSTEM/HEAT-PREWIRED
- 265 CODES/STANDARDS-CSA/CMVSS
- 1B1 CODES/STANDARDS USA



DSNR:		ALL DIMENSIONS ARE IN MILLIMETERS	
DFFR:		MATERIAL:	
UNSPECIFIED TOLERANCES:			
WHOLE DIM (X)	: 3		
ONE-PLACE (X.X)	: 1.5		
TWO-PLACE (X.XX)	: 0.50		
ANGLE	: 1°		
REFER TO ES0018 FOR FASTENER TIGHTENING GUIDELINES	WEIGHT: (LBS)	FIRST USED:	17 423A

DESCRIPTION:  
**WIRING INSTL-BODY, 12V**

SHEET:	ITEM/PART NO.:	REV:
1 OF 5	000022392 / 31443301000	

FOR ELECTRICAL TORQUE SPECIFICATIONS SEE DWG NO. 128783-01-000

FOR ELECTRICAL CALLOUTS SEE DWG NO. 121339-01-000

- 4 WITH 60T AMP TO BE MOUNTED ON UNDERSIDE OF FLOOR.
- 3 WIRE PASSES THROUGH FLOOR IN THIS AREA.
- 2 SPLICE YELLOW TO RED AND WHITE TO BLACK.

1. AT MINIMUM ALL WIRES TO BE SUPPORTED AND SECURED PER CODE REQUIREMENTS. USE CLAMP 10495 OR 10497 OR WIRE TIE 8343 OR 108046 AND SCREW G67-XX-XXX OR G56-XX-XXX AS APPROPRIATE FOR INSTALLATION.

NOTES:

SPEAKER  
171547-01-CHT (3)  
SPACER  
178966-01-000 (3)  
SCREW  
G11-08-16U (12)

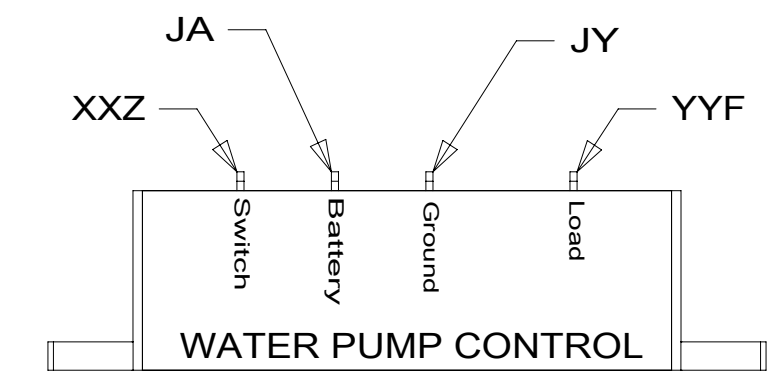

DETAIL BA

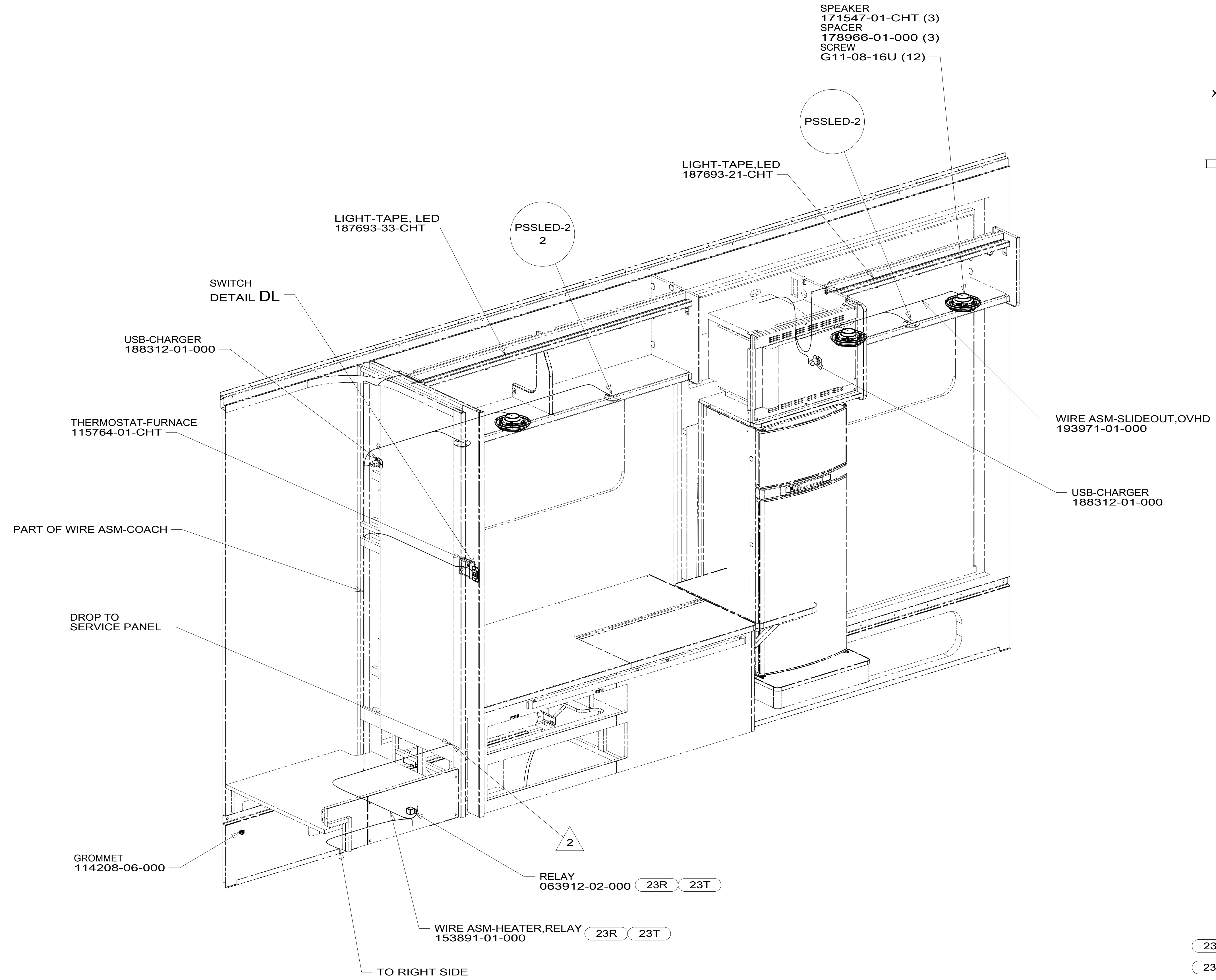

2 WIRE PASSES THROUGH FLOOR IN THIS AREA.

1. AT MINIMUM ALL WIRES TO BE SUPPORTED AND SECURED PER CODE REQUIREMENTS. USE CLAMP 10495 OR 10497 OR WIRE TIE 8343 OR 108046 AND SCREW G67-XX-XXX OR G56-XX-XXX AS APPROPRIATE FOR INSTALLATION.

NOTES:

FOR ELECTRICAL TORQUE SPECIFICATIONS SEE DWG NO. 128783-01-000

FOR ELECTRICAL CALLOUTS SEE DWG NO. 121339-01-000

- 23T DRAINAGE SYSTEM-HEATED
- 23R DRAINAGE SYSTEM/HEAT-PREWIRE
- 265 CODES/STANDARDS-CSA/CMVSS
- 1B1 CODES/STANDARDS USA

DESCRIPTION:		1B1 265	
<b>WIRING INSTL-BODY, 12V</b>			
SHEET:	ITEM/PART NO.:	REV	
2 OF 5	000022392 / 31443301000		



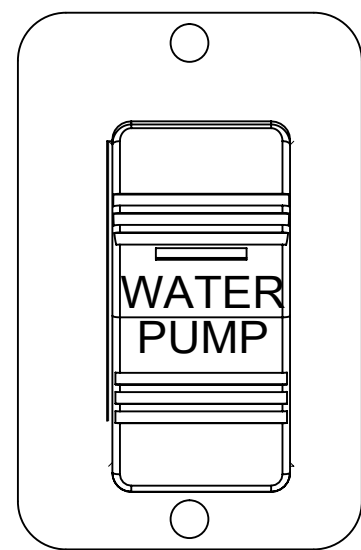

SWITCH-ROCKER  
108357-21-000  
ACTUATOR-SWITCH  
108356-23-CHT  
PLATE-SWITCH  
144363-02-CHT  
SCREW  
G11-06-10U (2)

DETAIL DA

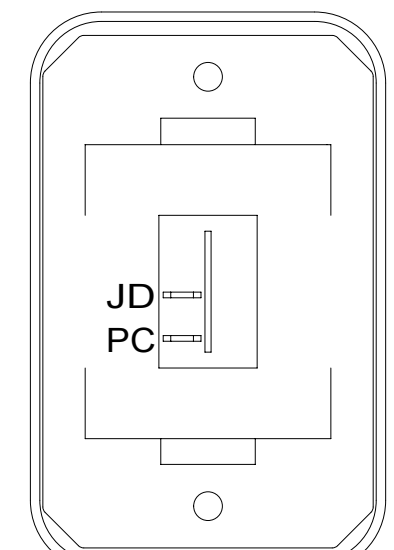

SWITCH-ROCKER  
135740-01-CHT  
SWITCH-BASE  
135741-01-CHT  
SWITCH-BEZEL  
135742-01-CHT  
SCREW  
G11-08-08U (2)

DETAIL DE

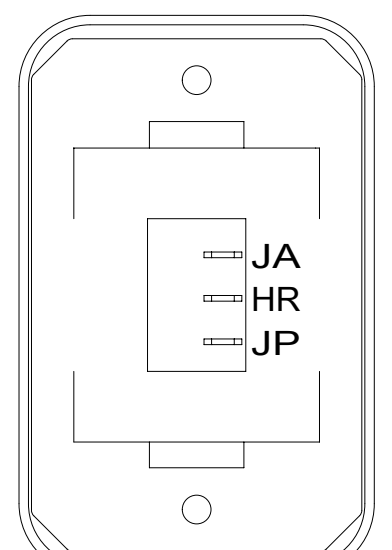

SWITCH-ROCKER  
135740-06-CHT  
SWITCH-BASE  
135741-01-CHT  
SWITCH-BEZEL  
135742-01-CHT  
SCREW  
G11-08-08U (2)

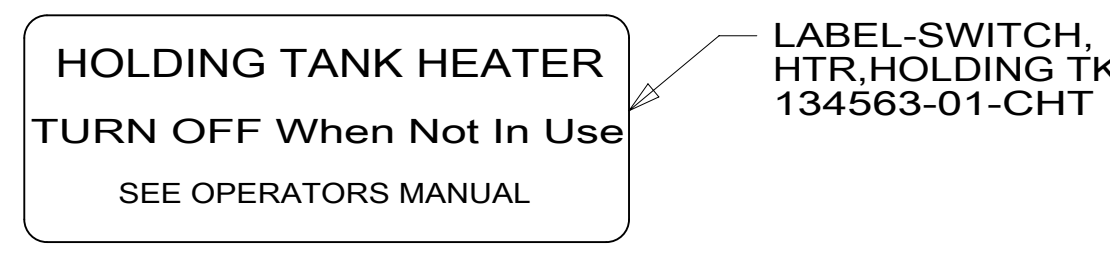

LABEL-SWITCH,  
HTR,HOLDING TK  
134563-01-CHT

DETAIL DG 23T 23R

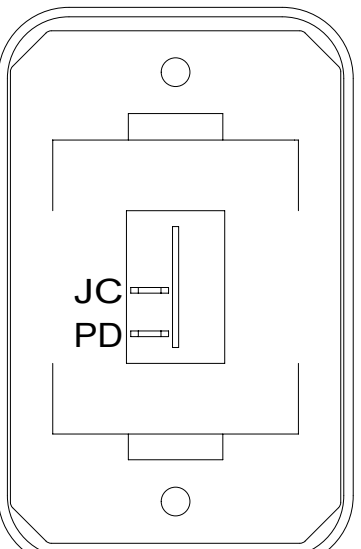

SWITCH-ROCKER  
135740-01-CHT  
SWITCH-BASE  
135741-01-CHT  
SWITCH-BEZEL  
135742-01-CHT  
SCREW  
G11-08-08U (2)

DETAIL DB

SWITCH-BATTERY  
108357-18-000  
ACTUATOR-SWITCH  
108356-19-CHT  
CIRCUITS LH,LG,  
LJ-1,JC,NC  
WIRE ASM-THERMISTOR  
186796-01-000

SWITCH-ROCKER  
108357-01-000  
ACTUATOR-SWITCH  
108356-22-CHT  
CIRCUITS  
FFD,FFT

SWITCH-ROCKER  
108357-06-000  
ACTUATOR-SWITCH  
108356-12-CHT  
CIRCUITS FFN,FFP,FFR

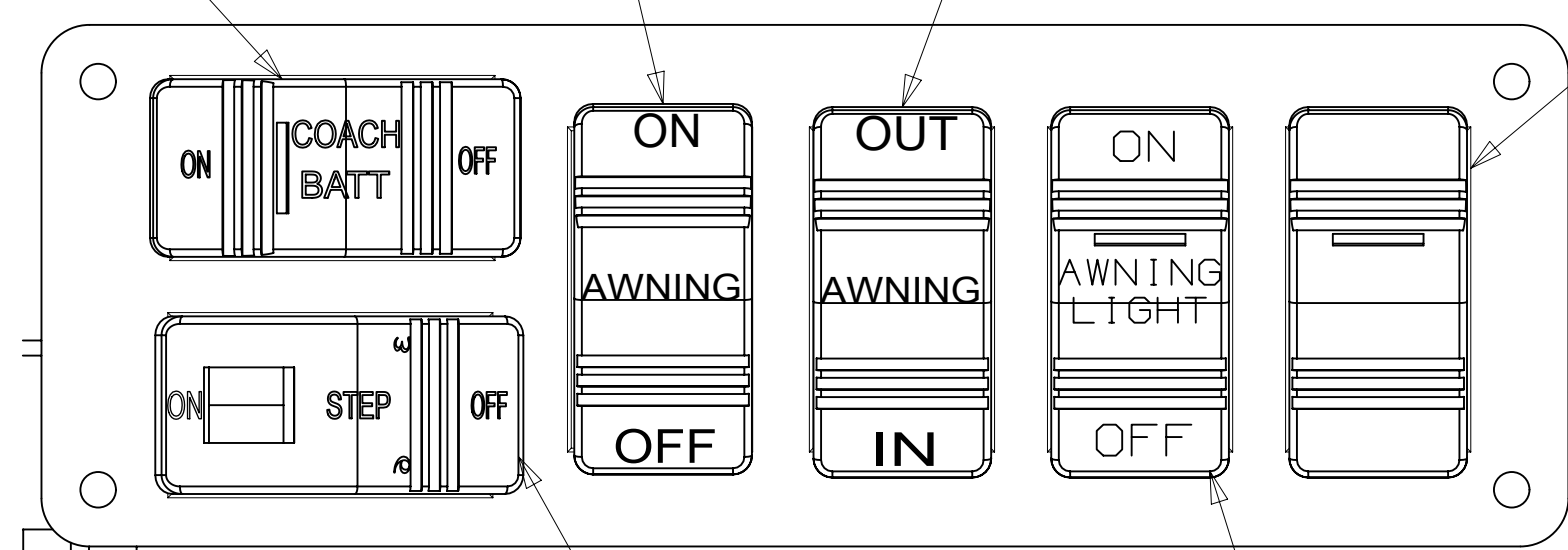

SWITCH-ROCKER  
108357-14-000  
ACTUATOR-SWITCH  
108356-03-000  
CIRCUITS AES,AET,NC

PLATE-SWITCH  
00022055 / 314395-01-CHT  
SCREW  
G11-06-10U (4)

SWITCH-ROCKER  
108357-19-000  
CIRCUITS ER,ES

SWITCH-ROCKER  
108357-14-000  
ACTUATOR-SWITCH  
108356-28-CHT  
CIRCUITS RS,ZZK,NC

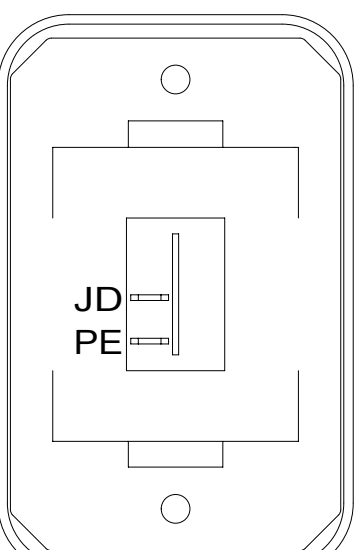

SWITCH-ROCKER  
135740-01-CHT  
SWITCH-BASE  
135741-01-CHT  
SWITCH-BEZEL  
135742-01-CHT  
SCREW  
G11-08-08U (2)

DETAIL DC

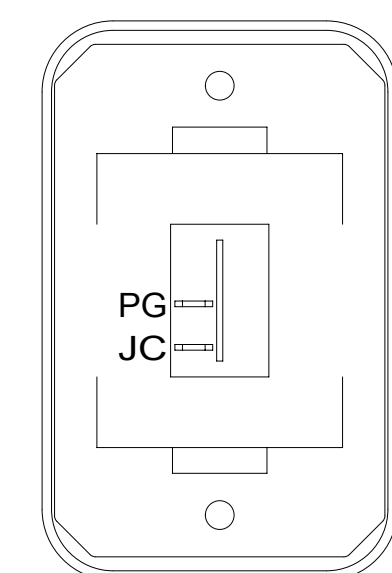

SWITCH-ROCKER  
135740-01-CHT  
SWITCH-BASE  
135741-01-CHT  
SWITCH-BEZEL  
135742-01-CHT  
SCREW  
G11-08-08U (2)

DETAIL DL

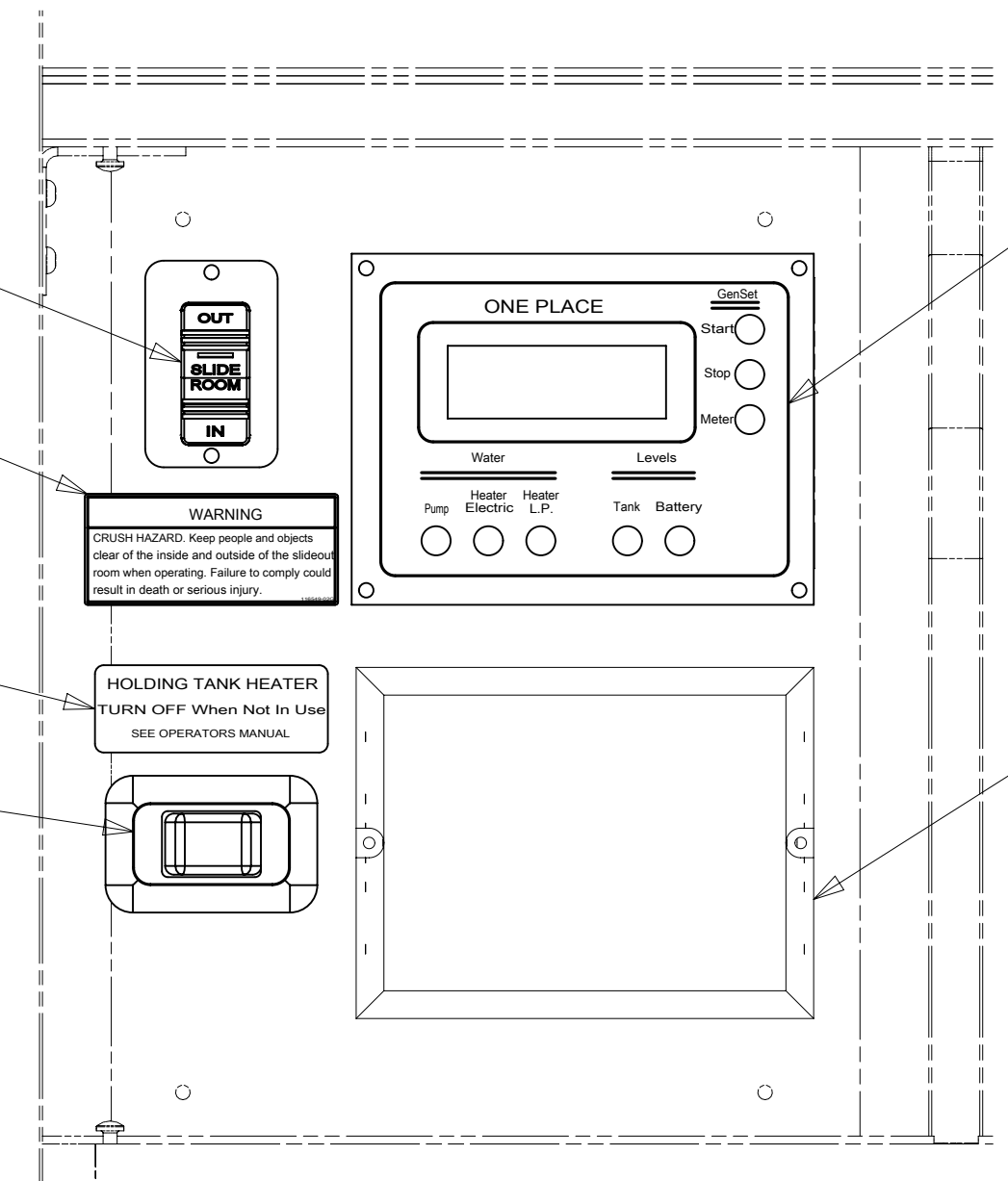

VIEW DH

PANEL-MONITOR,LCD  
175724-01-000  
SCREW  
G11-08-08U (4) 1A3 1G8 384

CONTROL-CHARGE,  
SOLAR 30 AMP  
191278-01-000 282  
SCREW  
G11-08-08U (2)  
DETAIL DK

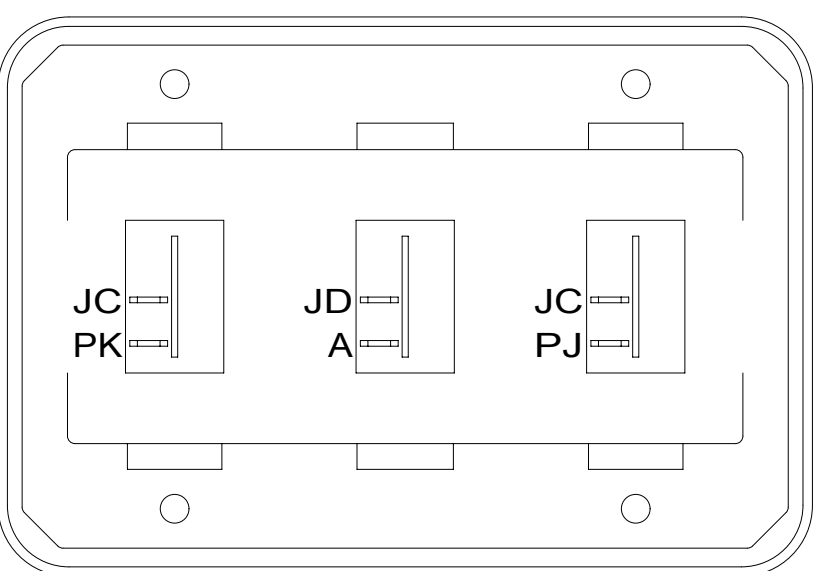

SWITCH-ROCKER  
135740-01-CHT (3)  
SWITCH-BASE  
135741-03-CHT  
SWITCH-BEZEL  
135742-03-CHT  
SCREW  
G11-08-08U (4)

DETAIL DD

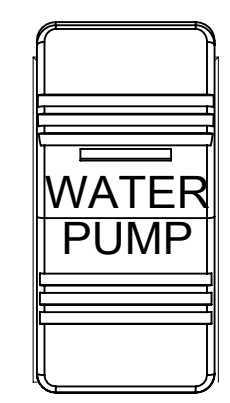

SWITCH-ROCKER  
108357-21-000  
ACTUATOR-SWITCH  
108356-23-CHT

DETAIL DJ

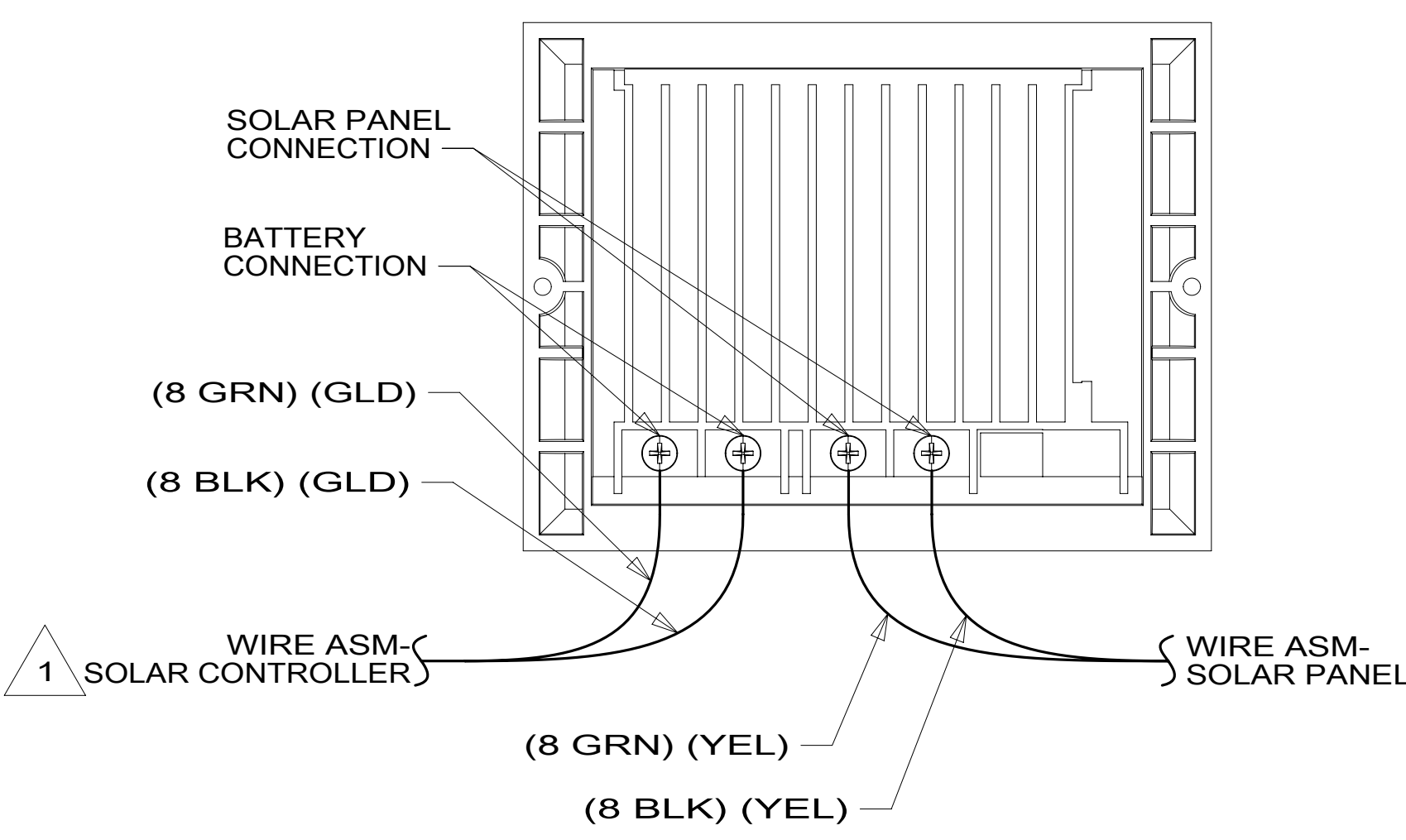

DETAIL DK

1 SEE WIRING INSTL-CHASSIS FOR ADDITIONAL INFORMATION.

FOR ELECTRICAL  
TORQUE  
SPECIFICATIONS  
SEE DWG NO.  
128783-01-000

FOR  
ELECTRICAL  
CALLOUTS  
SEE DWG NO.  
121339-01-000

- 384 GEN 2.5KW ONAN-LP
- 1G8 GEN-2.8KW ONAN GAS
- 1A3 GENERATOR WITHOUT
- 282 SOLAR PANEL - 100 WATT
- 23R DRAINAGE SYSTEM/HEAT-PREWIRE
- 23T DRAINAGE SYSTEM-HEATED
- 265 CODES/STANDARDS-CSA/CMVSS
- 1B1 CODES/STANDARDS USA

DESCRIPTION: <b>WIRING INSTL-BODY, 12V</b>	
SHEET: 4 OF 5	ITEM/PART NO: 000022392 / 31443301000
REV	

PRLED-4  
9

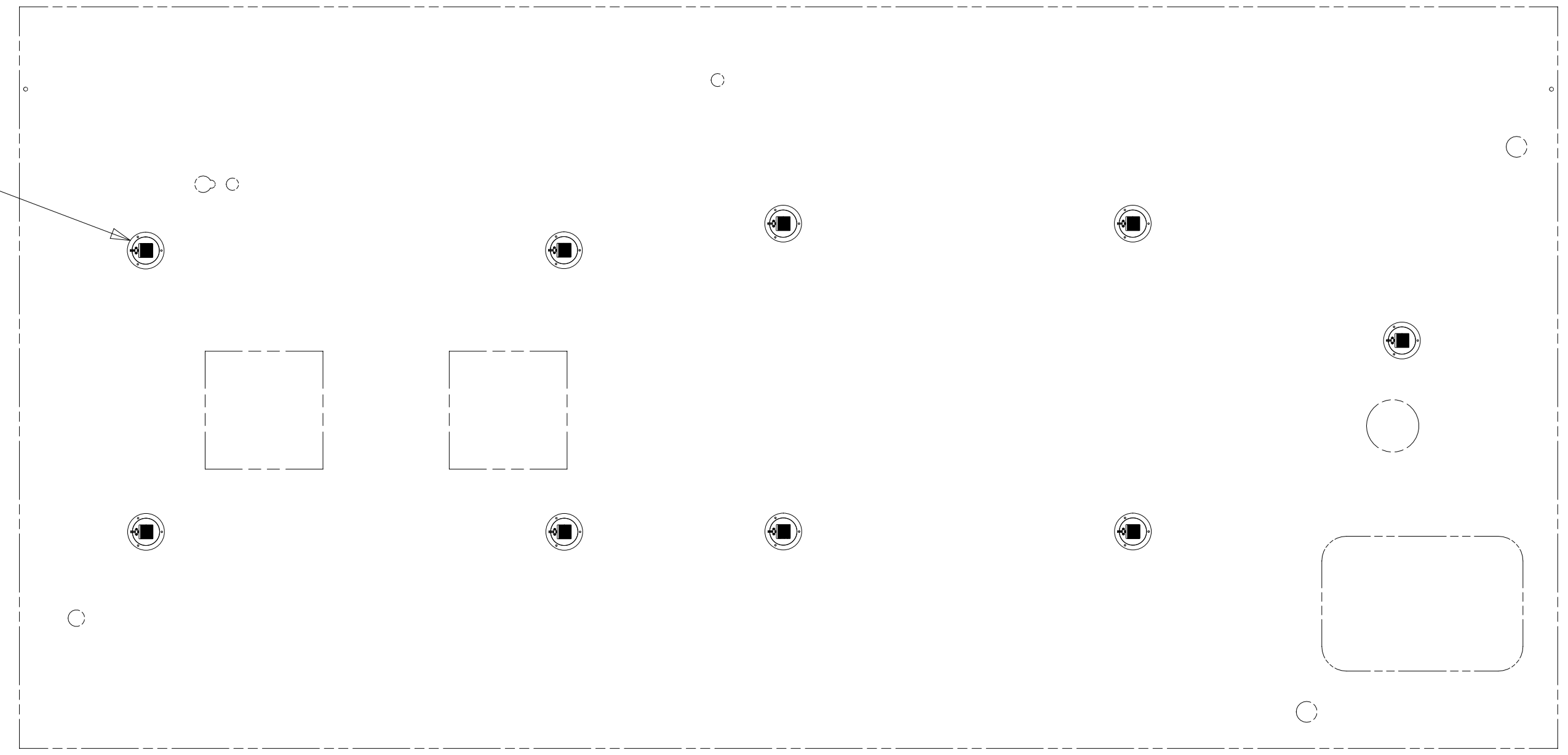

PANEL-SOLAR 100 WATT  
191276-01-CHT  
MOUNTING FEET-SOLAR, QTY 4  
000031418 / 316962-01-000  
SCREW  
G39-10-10U (8) 282

1 ANT-8

DETAIL EB

PORT-SOLAR,  
3 POSITION  
191277-01-CHT  
DETAIL EC 282

ANT-R  
VIEW EA

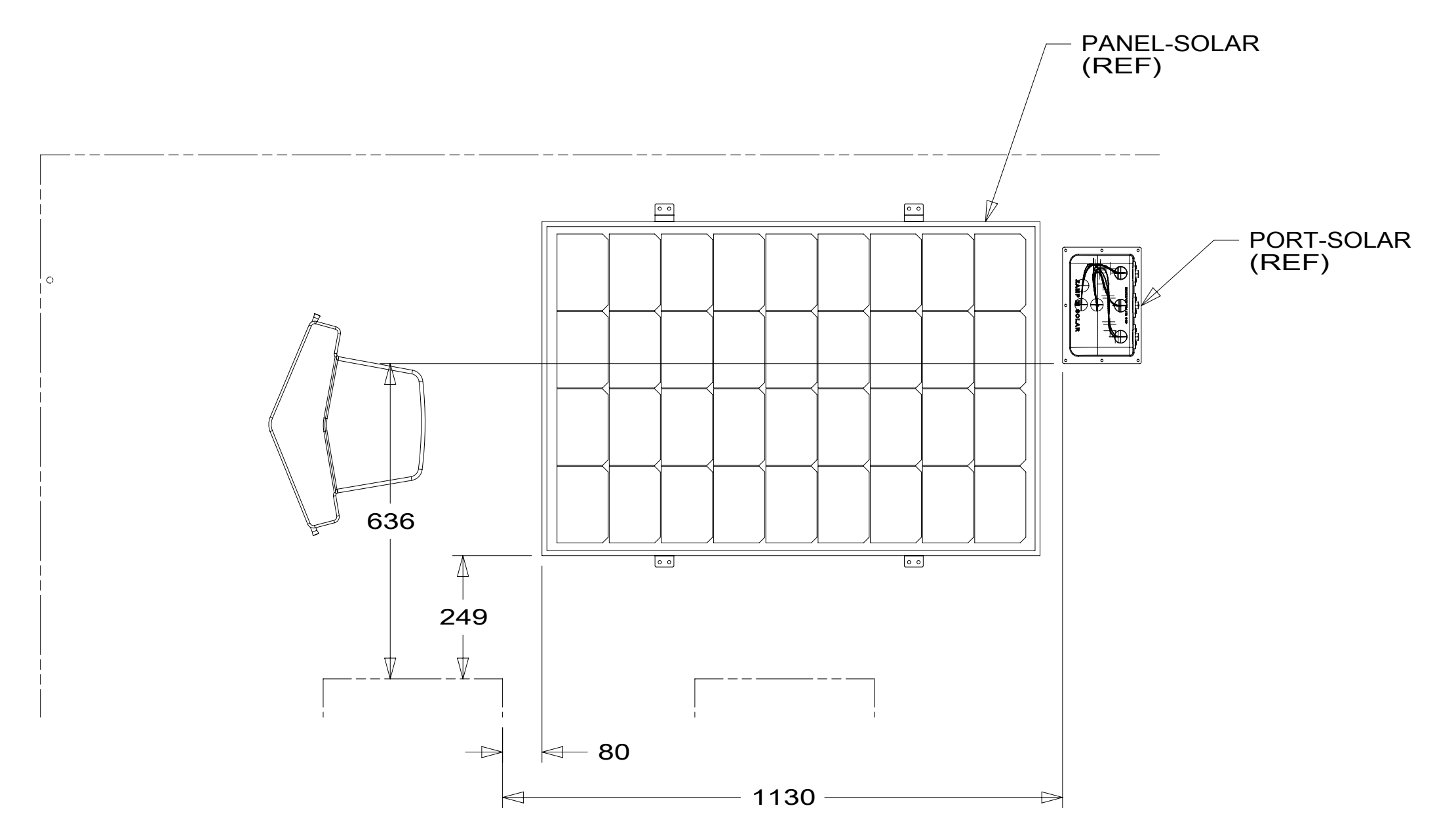
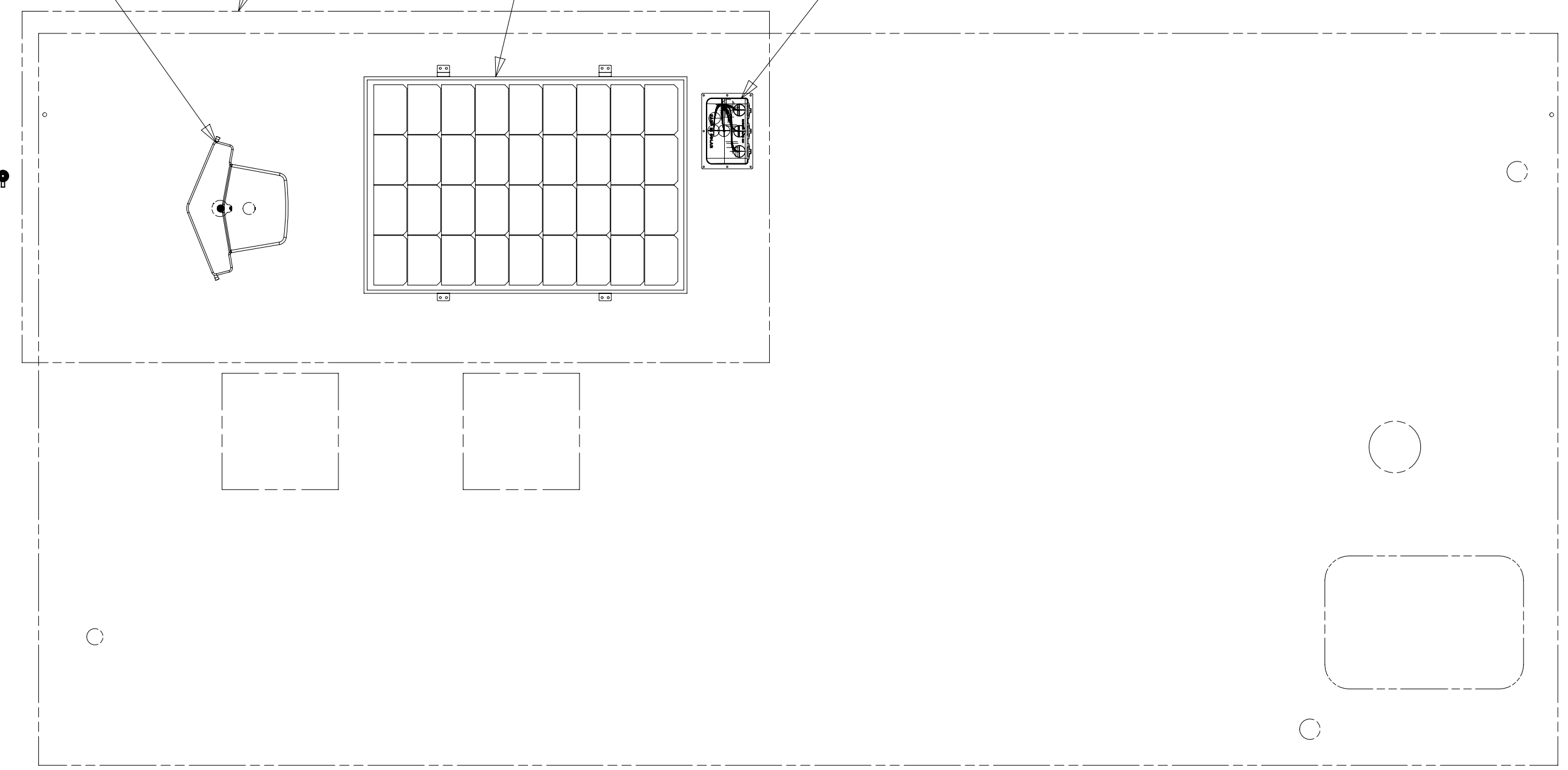

DETAIL EB

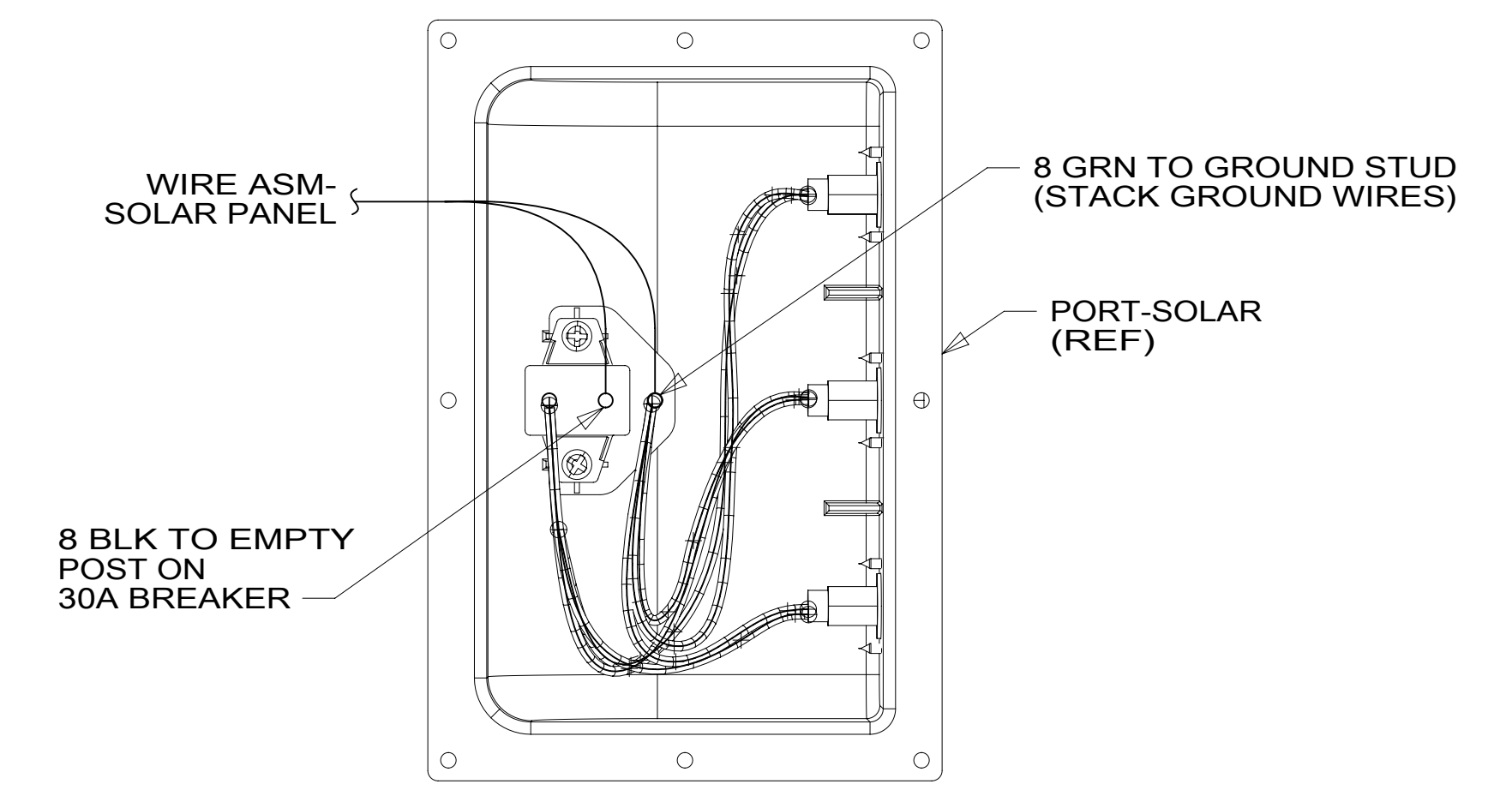

DETAIL EC

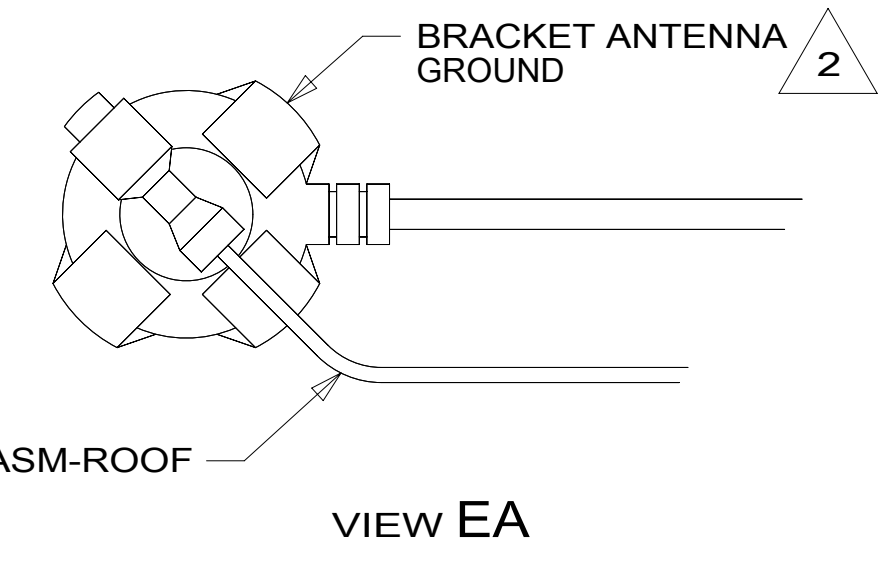

VIEW EA

- NOTES:
- 2 WRAP BRACKET LEGS AROUND ANTENNA BASE.
  - 1 SEE ANTENNA INSTALLATION MANUAL FOR CORRECT INSTALLATION PROCEDURE.

FOR ELECTRICAL TORQUE SPECIFICATIONS SEE DWG NO. 128783-01-000

FOR ELECTRICAL CALLOUTS SEE DWG NO. 121339-01-000

- 282 SOLAR PANEL - 100 WATT
- 265 CODES/STANDARDS-CSA/CMVSS
- 1B1 CODES/STANDARDS USA

DESCRIPTION: <b>WIRING INSTL-BODY, 12V</b>		
SHEET: 5 OF 5	ITEM/PART NO: 000022392 / 31443301000	REV