

DETAIL AA

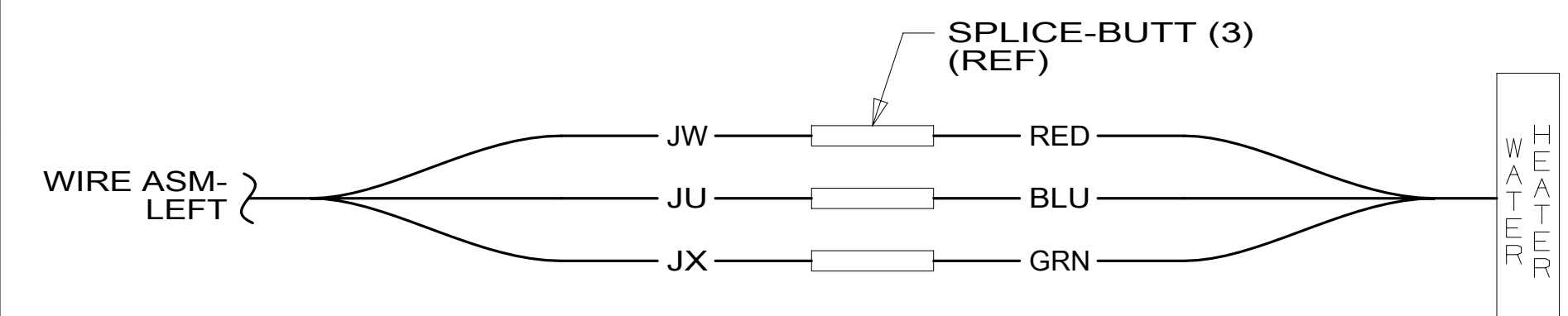

DETAIL AB

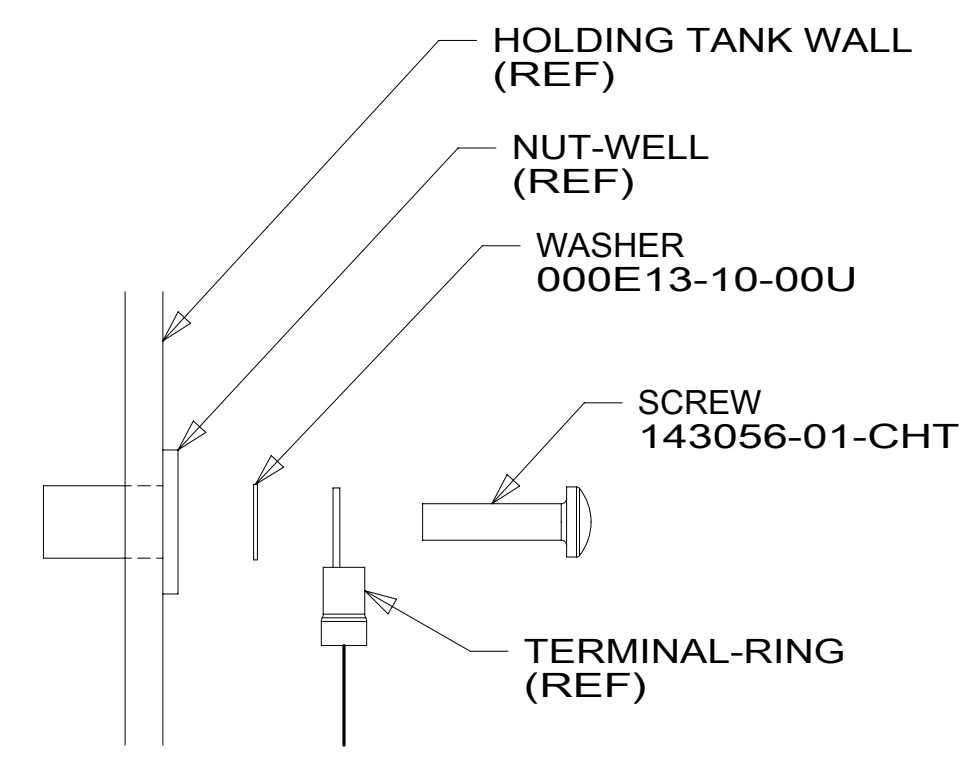
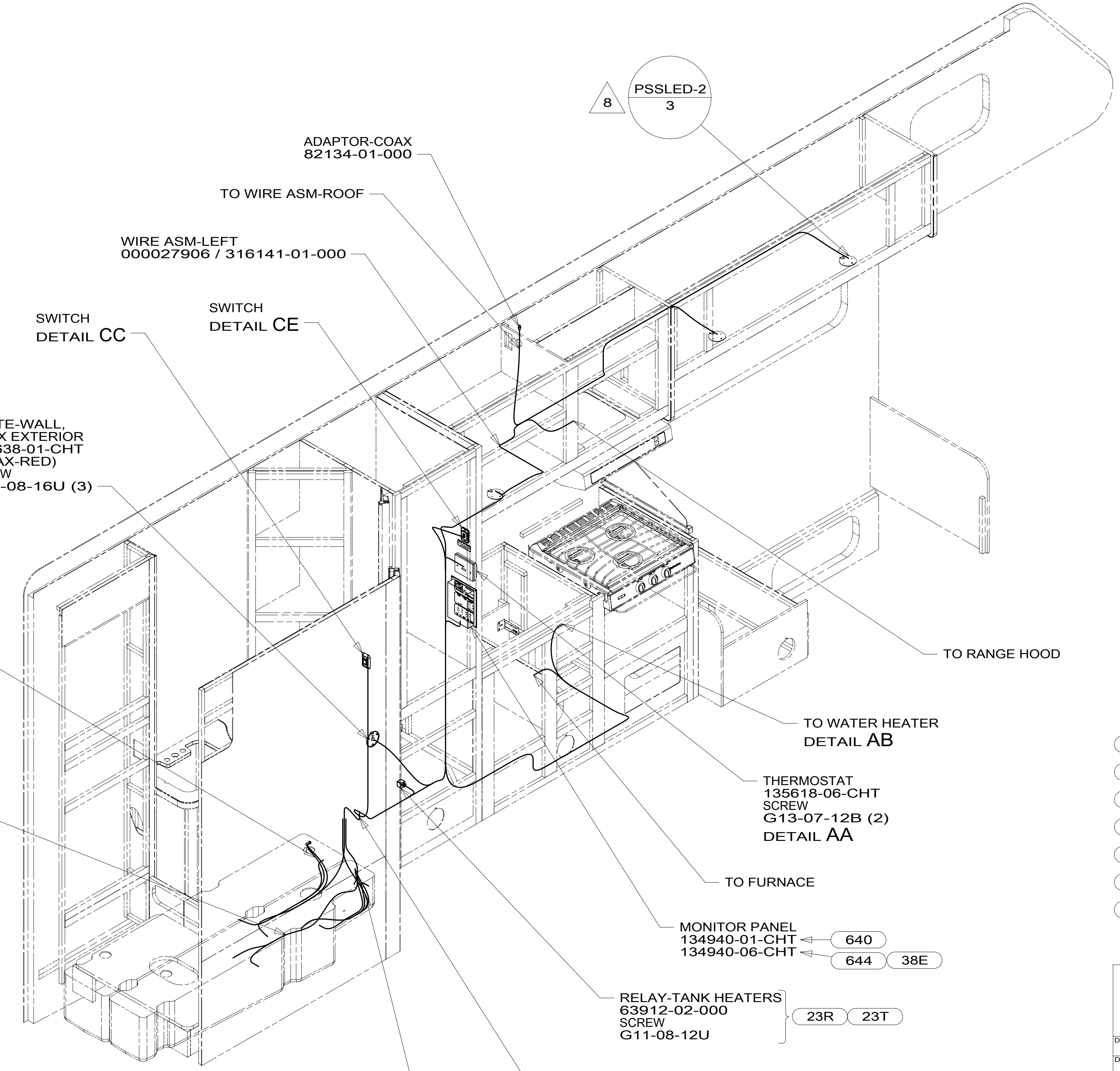

DETAIL AC 6

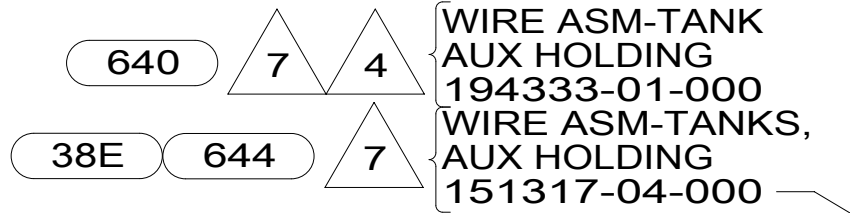

- 8 SWITCH ON LAMP TO BE ORIENTED TO REAR OF CABINET.
- 7 MARK WIRES WITH WRAP OF ORG TAPE.
- 6 TYPICAL WIRE ATTACHMENT AT ALL LEVEL PROBES (4 EACH) FOR WATER, MAIN, AND AUX HOLDING TANKS.
- 5 MARK WIRES WITH WRAP OF BLU TAPE.
- 4 SEE DETAIL AC FOR WIRING AND CONNECTION TO SENSOR PROBES.
- 3 SEE DRAINAGE SYSTEM INSTALLATION FOR ADDITIONAL INFORMATION.
- 2 WIRE ROUTED ALONG DRAINAGE PIPE AND CONNECTED TO PIPE WITH TIE-WIRE 8343-04-000.

1. AT MINIMUM ALL WIRES TO BE SUPPORTED AND SECURED PER CODE REQUIREMENTS. USE CLAMP 10495 OR 10497 OR WIRE TIE 8343 OR 108046 AND SCREW G67-XX-XXX OR G56-XX-XXX AS APPROPRIATE FOR INSTALLATION.

NOTES:

- 38E CONVENIENCE PACKAGE
- 640 RENTAL - GAH WITHOUT
- 644 GREAT ALASKAN RENTAL PACKAGE
- 23R DRAINAGE SYSTEM/HEAT-PREWIRE
- 23T DRAINAGE SYSTEM-HEATED
- 265 CODES/STANDARDS-CSA/CMVSS
- 1B1 CODES/STANDARDS USA



DSNR:		ALL DIMENSIONS ARE IN MILLIMETERS	
DIFFR:		MATERIAL:	
UNSPECIFIED TOLERANCES:	WHOLE DIM (X)	3	
	ONE-PLACE (X.X)	1.5	
	TWO-PLACE (X.XX)	0.50	
	ANGLE	1°	
REFER TO ES0018 FOR FASTENER TIGHTENING GUIDELINES		WEIGHT: (LBS)	FIRST USED: 17 325B
DESCRIPTION: WIRING INSTL-BODY, 12V			
SHEET: 1 OF 4	ITEM/PART NO: 000018697 / 31368401000	REV:	

FOR ELECTRICAL TORQUE SPECIFICATIONS SEE DWG NO. 128783-01-000

FOR ELECTRICAL CALLOUTS SEE DWG NO. 121339-01-000

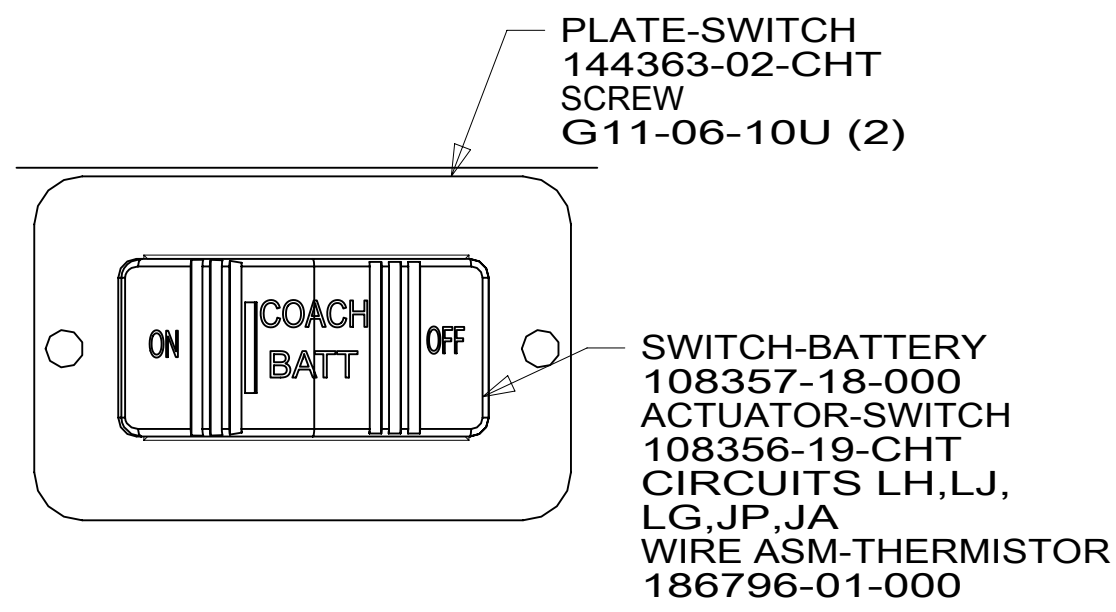

DETAIL CA

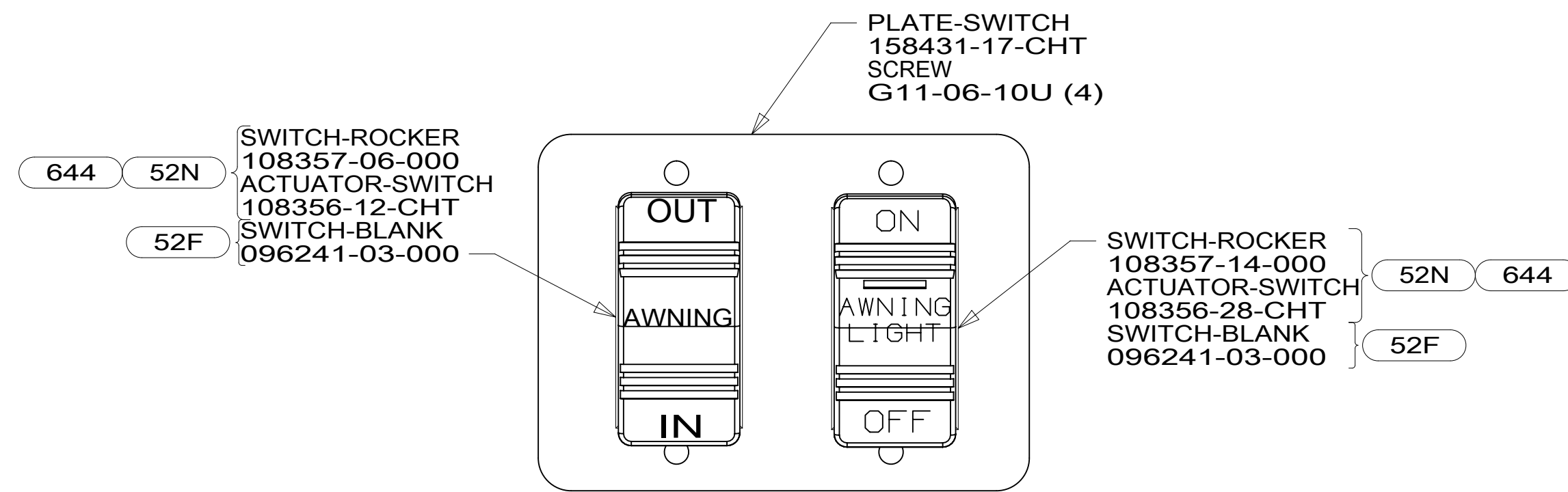

DETAIL CD

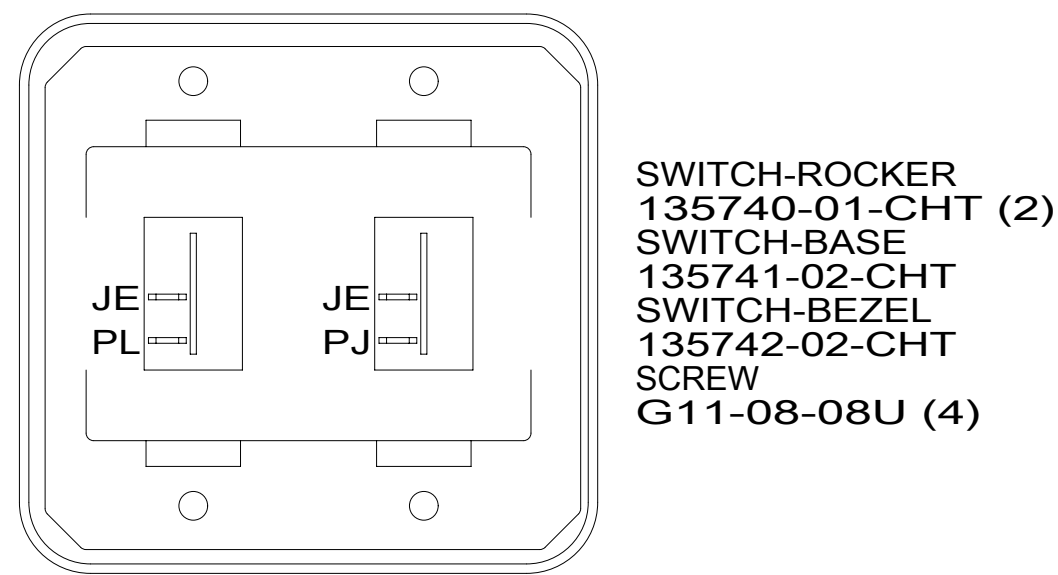

DETAIL CB

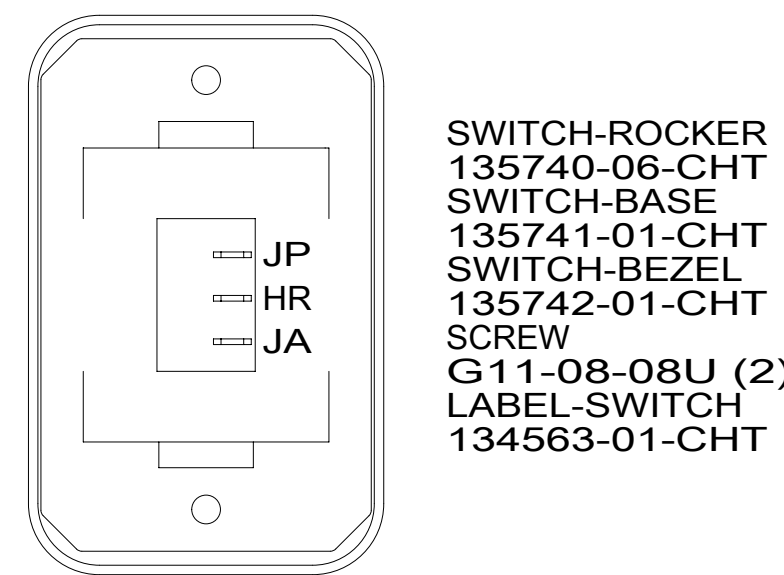

HOLDING TANK HEATER
TURN OFF When Not In Use
SEE OPERATORS MANUAL

DETAIL CE 23T 23R

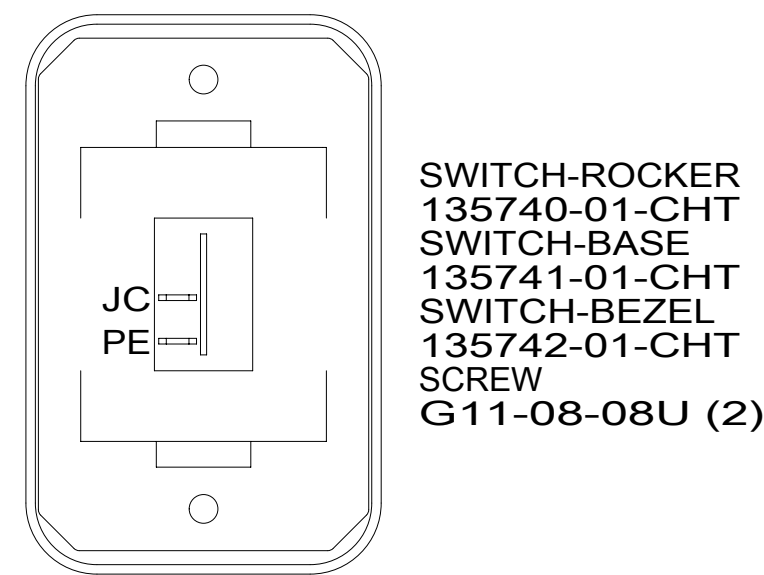

DETAIL CC

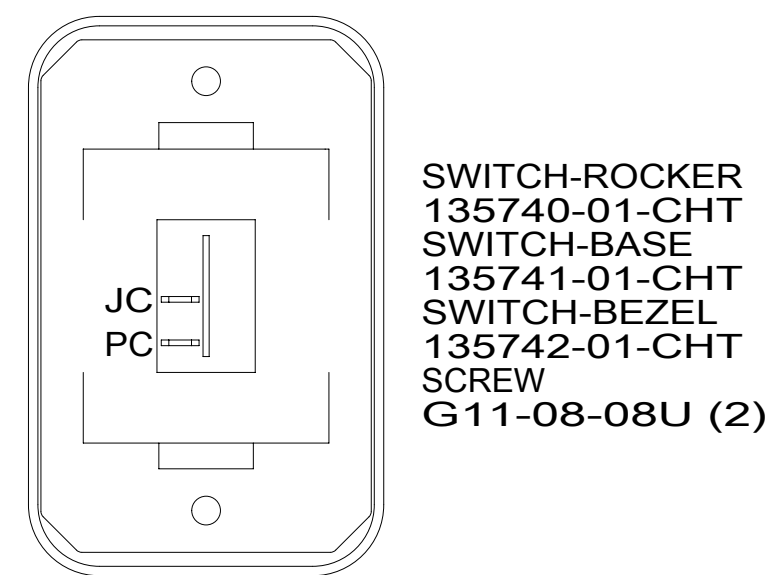

DETAIL CF

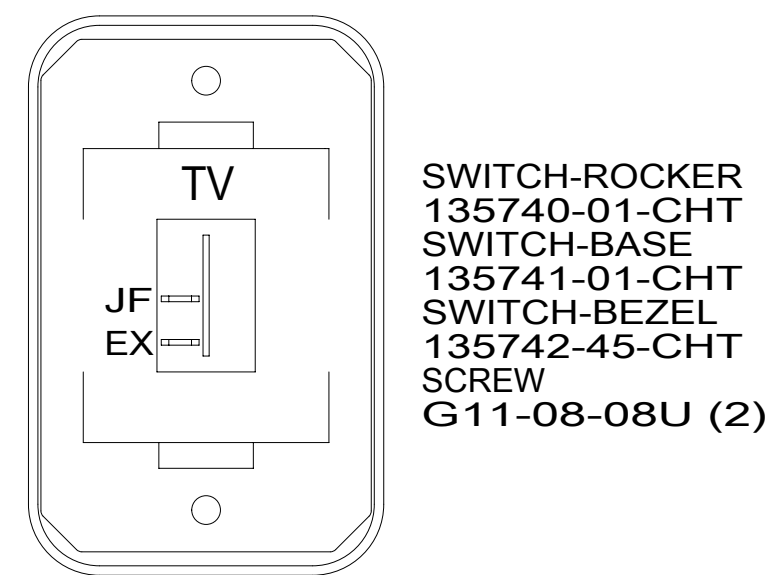

DETAIL CG

- 52N AWNING - PATIO, ELECTRIC
- 52F AWNING-PATIO
- 644 GREAT ALASKAN RENTAL PACKAGE
- 23T DRAINAGE SYSTEM-HEATED
- 265 CODES/STANDARDS-CSA/CMVSS
- 1B1 CODES/STANDARDS USA

FOR ELECTRICAL
TORQUE
SPECIFICATIONS
SEE DWG NO.
128783-01-000

FOR
ELECTRICAL
CALLOUTS
SEE DWG NO.
121339-01-000

1B1 265

DESCRIPTION:
WIRING INSTL-BODY, 12V

SHEET: 3 OF 4 ITEM/PART NO: 000018697 / 31368401000 REV

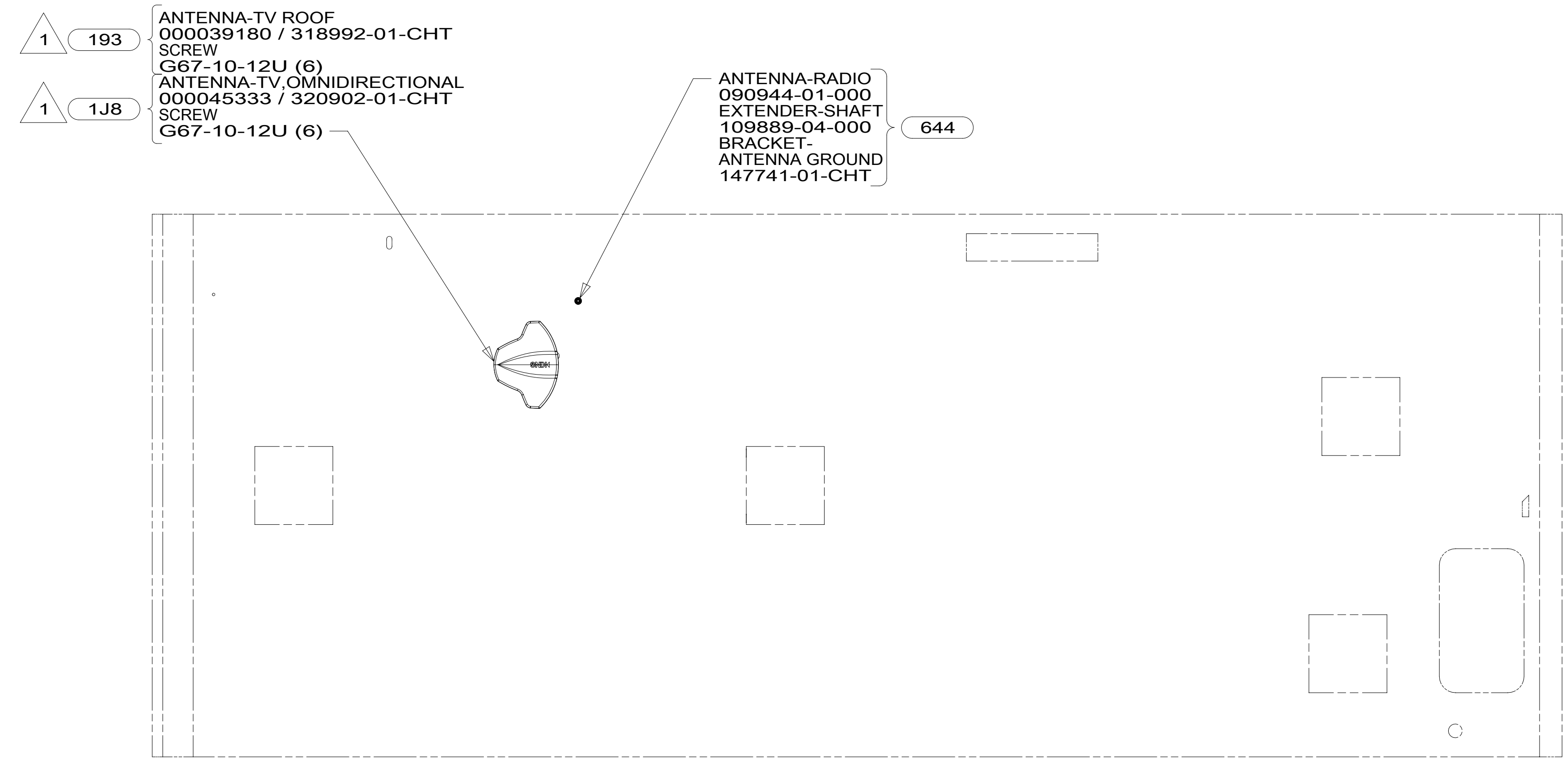
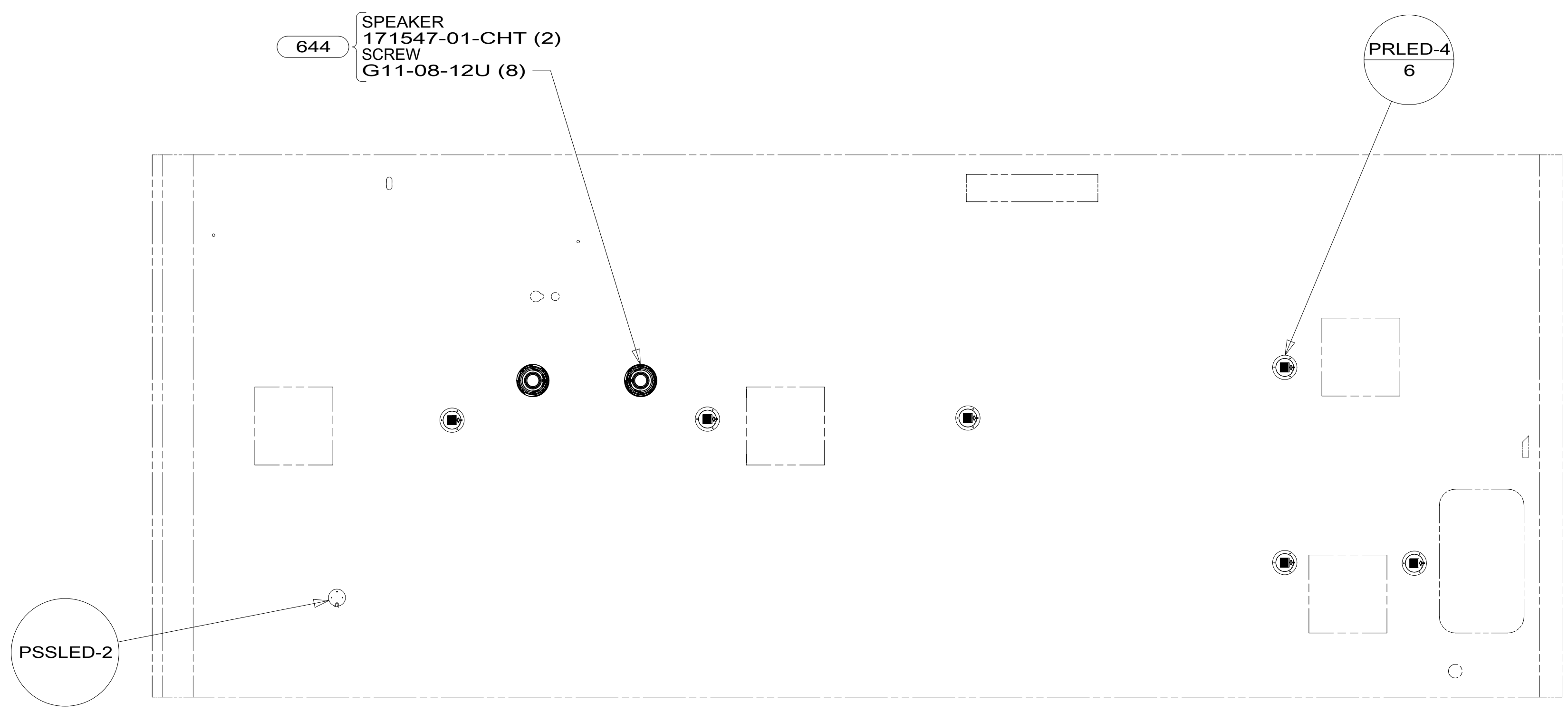

- 644 GREAT ALASKAN RENTAL PACKAGE
- 1J8 TV ANTENNA-OMNIDIRECTIONAL
- 193 TV ANTENNA-AMPLIFIED SYSTEM
- 265 CODES/STANDARDS-CSA/CMVSS
- 1B1 CODES/STANDARDS USA

1 SEE ANTENNA INSTALLATION MANUAL FOR CORRECT INSTALLATION PROCEDURE.

FOR ELECTRICAL TORQUE SPECIFICATIONS SEE DWG NO. 128783-01-000

FOR ELECTRICAL CALLOUTS SEE DWG NO. 121339-01-000

1B1	265
DESCRIPTION:	
WIRING INSTL-BODY, 12V	
SHEET:	ITEM/PART NO:
4 OF 4	000018697 / 31368401000
REV	